

Cast Iron Strainers: Model 381AE

"Y" pattern, stainless steel screen, bolted cover, flanged ends.



Material

No.	Name of parts	ASTM Specification	
1	Body	Cast iron	A126 Class B
2	Cover	Cast iron	A126 Class B
3	Screen	Stainless steel	A126 Type 304
4	Cover bolt	Steel*	A307 Grade B
5	Cover bolt nut	Steel*	A307 Grade B
6	Gasket	Non-asbestos joint sheet	
7	Drain plug	Malleable iron	A197

*Zinc plated

Working pressures

Working pressure Non-shock			Test pressure
Saturated		water, Oil & Gas	Shell
Psig	125	200	900
Bar	8.6	13.8	62.1

- Note :
1. End flange dimensions and drillings conform to ASME B 16.1 End flanges are fully flat faced and smoothly finished in accordance with MSS SP-6.
 2. JIS10K and BS/DIN PN16 flanged ends are available upon request.
 3. The standard perforated screen is equivalent to 14-16 meshes.
 4. 10-60 meshed screen is available upon request.

*Design and materials are subject to change without notice.

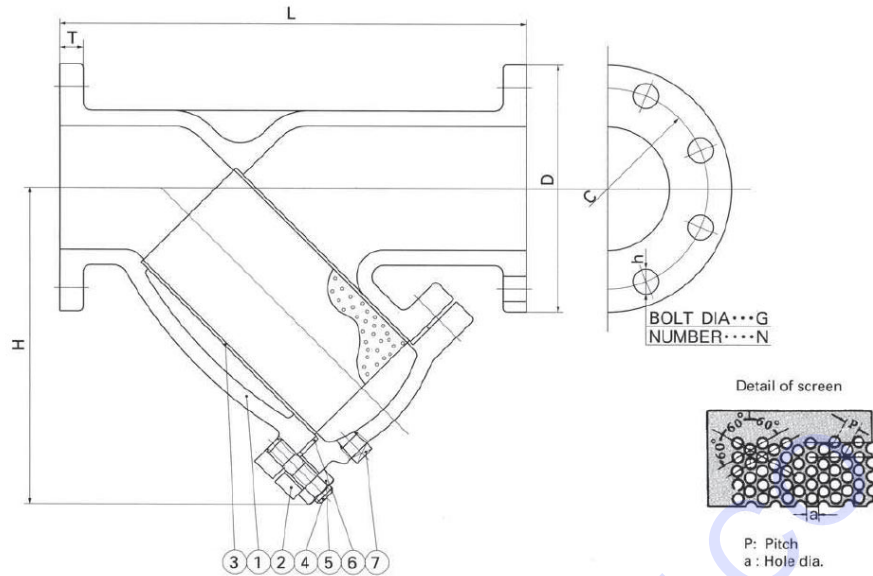

Dimension

Size	Mark	L	H	Flanges						Screen		Weight	
				D	C	N	h	G	T	a	p	lb	kg.
2	in.	8.86	5.67	6.00	4.75	4	0.75	0.62	0.62	0.059	0.099	22	10
	mm.	225	144	152	121		19.0	15.9	15.9	1.5	2.5		
2 ½	in.	10.75	6.93	7.00	5.50	4	0.75	0.62	0.62	0.059	0.099	35	16
	mm.	273	176	178	140		19.0	15.9	17.5	1.5	2.5		
3	in.	11.5	7.68	7.50	6.00	4	0.75	0.62	0.75	0.059	0.099	51	23
	mm.	292	195	191	152		19.0	15.9	19.0	1.5	2.5		
4	in.	13.86	9.69	9.00	7.50	8	0.75	0.62	0.94	0.059	0.099	75	34
	mm.	352	246	229	191		19.0	15.9	23.8	1.5	2.5		
5	in.	15.39	11.81	10.00	8.50	8	0.88	0.75	0.94	0.059	0.099	115	52
	mm.	391	300	254	216		22.2	19.0	23.8	1.5	2.5		
6	in.	18.5	12.64	11.00	9.50	8	0.88	0.75	1.00	0.059	0.099	154	70
	mm.	470	321	279	241		22.2	19.0	25.4	1.5	2.5		
8	in.	21.38	15.67	13.50	11.75	8	0.88	0.75	1.12	0.059	0.099	243	110
	mm.	543	398	343	299		22.2	19.0	28.6	1.5	2.5		
10	in.	25.98	19.02	16.00	14.25	12	1.00	0.88	1.19	0.079	0.118	390	177
	mm.	660	483	406	362		25.4	22.2	30.2	2.0	3.0		
12	in.	30	22.05	19.00	17.00	12	1.00	0.88	1.25	0.079	0.118	650	295
	mm.	762	560	483	432		25.4	22.2	31.8	2.0	3.0		

Data of screen

Data	Size	2	2 ½	3	4	5	6	8	10	12
	Number of holes	in ²	119.4	119.4	119.4	119.4	119.4	119.4	119.4	82.8
	cm ²	18.5	18.5	18.5	18.5	18.5	18.5	18.5	12.8	12.8
Open area (%)		32.7	32.7	32.7	32.7	32.7	32.7	32.7	40.3	40.3
Total Screen area	in ²	34.52	41.58	57.08	94.97	161.22	222.81	376.61	565.88	780.58
	cm ²	222.72	268.25	368.24	612.70	1040.12	1437.49	2429.74	3650.84	5036.00