

LED ฟลัดไลท์ พลังงานแสงอาทิตย์ รุ่น APOLLO series



2,500 lm
Lumen(max)

200W



WIRELESS
REMOTE CONTROL



รหัสสินค้า Code	ชื่อสินค้า	ขนาดวัตต์ Power (w)	แสง Color	แผงโซล่า
--------------------	------------	------------------------	--------------	----------

LTLSSM05NM015200GDL	SOLAR FLOOD LIGHT (APOLLO)	200W	Daylight (6000 - 6500K)	5V/15W (Polysilicon solar panel)
---------------------	---------------------------------	------	----------------------------	-------------------------------------



General Information

Product	SOLAR FLOOD LIGHT (APOLLO)
SMD Chip	SMD2835 SANAN,158pcs
Battery	3.2V/ 12AH
Safety Class	N/A
IP Code	65
Lamp body information	Aluminum + PC
Body Color	Grey
Charge and discharge times	> 1,200 times
Solar panel	5V/15W
Charging	4-6 Hrs
Working duration	12-15 Hrs, 1-2 consecutive cloudy and rainy days
Control mode	intelligent remote control of 6 m + light-operated

Dimension

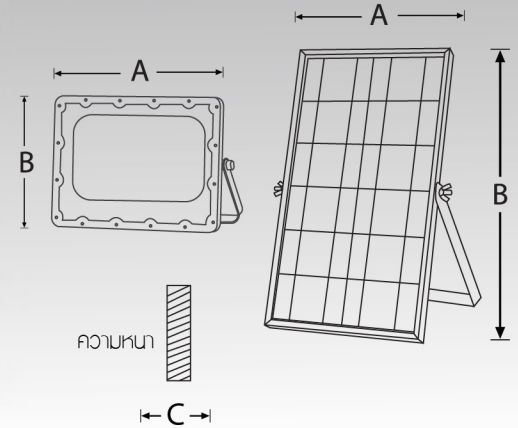

Installation Guide

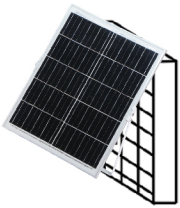

Use 2 expansion screws to fix the solar panels on the wall

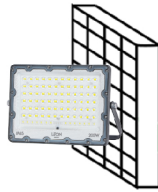

Use 2 expansion screws to fix the solar lamp on the wall



Plug the twist after the twist cap

Tips The battery must be fully charged before using 3-5 rainy days.

Dimensions : mm. A B C

Lamp	253 X 172 X 44
Solar panel	350 X 290 X 17

Remote control key instructions

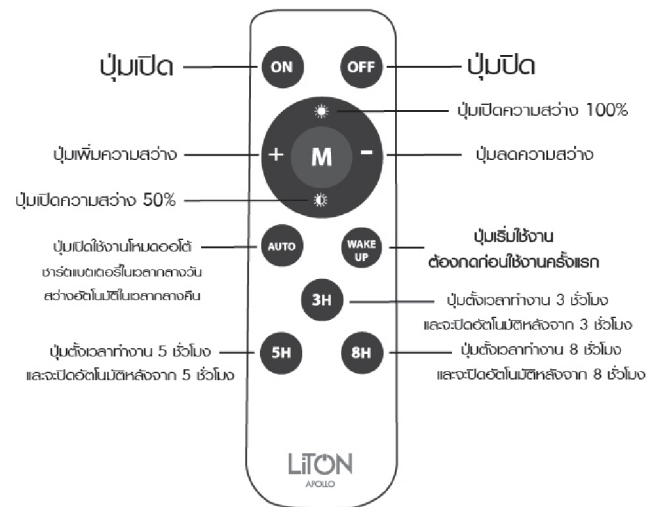

Solar panel



Solar light



Remote control



expansion screw

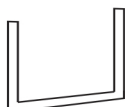

U-frame



5m wire