

MaxX125

NEW

The little, big lifter

This new compact and powerful hand operated magnetic lifter makes easy and safe to handle a large variety of ferrous loads, flat or round weighting up to 125 kg.

The productivity increases, improving the working ergonomics and avoiding the use of dangerous straps and chains.



Loads with limited contact surfaces can be safely handled and the deposit area can be optimized.



Advanced characteristics for performances of excellence

- > Practical and effective spring loaded locking device
- > High energy permanent magnets
- > Nickel coating for all ferrous parts
- > 3 times safety factor on the rated load
- > No power supply or batter back up needed
- > No maintenance required

MaxX: the manual lifters most sold in the world



The ideal solution for workshops, warehouses and transporters.

With the arrival of the model 125 the MaxX family now includes a full range of lifters with capacity ranging from 125 to 2000 kg loads, always at the top of compactness, power, and robustness.



TECNOMAGNETE®
Safety through Power

MaxX125

Just turning the lever to activate the lifter: the load will remain held only by the strength of the permanent magnets for an indefinite period of time without power loss.



The load will be lifted always from the top side, even if stacked, without any damage or deformation.



Spring-lock safety device.



The nickel coating prevents rust formation of all the ferrous parts whilst increasing surface hardness to prevent polar area wearing during the time, granting long lasting high performances.



The rotating hook increases the operation flexibility even in tight spaces.

An innovative construction concept



All the MaxX line is based on a revolutionary and patented manufacturing "monoblock" project able to grant the maximum efficiency of the magnetic circuit together with an high level of durability and reliability over the time.

LOAD CHARACTERISTICS (on Fe 370B load)					
flat			round		
load max	thickness min	length max	load max	thickness min	length max
Kg	mm	mm	Kg	mm	mm
125	20	1000	50	10	300

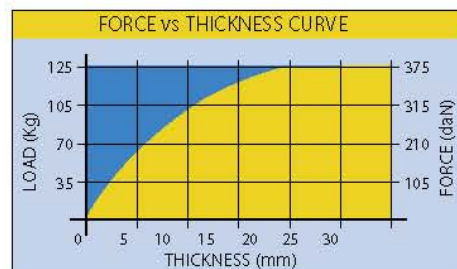
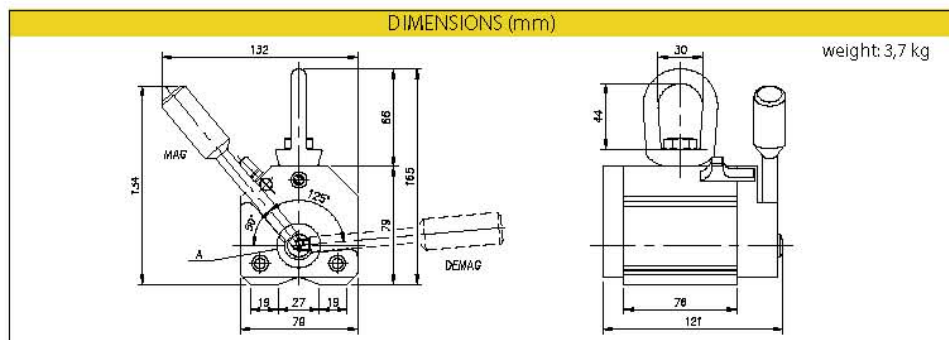
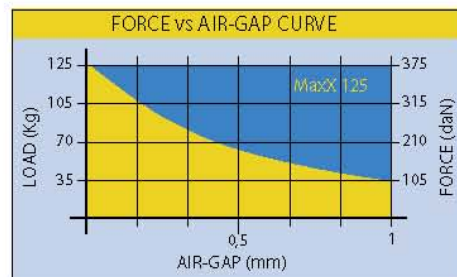

All data were prepared and checked with the greatest care but we do not accept responsibility for any errors or omissions. We reserve the right to make changes connected with technical progress.

TITAN[®]
TITAN CRANE CO., LTD.

1/19 หมู่ 1 ต.พิมพา อ.บางปะกง จ.ฉะเชิงเทรา 24180
โทร. +66(038)571 666-9 แฟกซ์ : +66(038)571 665
1/19 MOO 1 PIMPA, BANGPAKONG, CHACHOENSAO 24180
Tel. +66(038)571 666-9 Fax : +66(038)571 665
www.titancrane.co.th E-mail : titancranemail@yahoo.com