

CHAIN HOIST



POWER AND DURABILITY

Street



Certificate No. FM13635



MADE IN ENGLAND

PERFORMANCE THROUGH EVOLUTION AND INNOVATION

“To achieve the highest possible levels of performance and reliability it is necessary to continuously learn from experience...

...invest in R&D and pay attention to even the smallest possibility for improvement. Only then can new bench marks for efficient performance and operating reliability be set. Only then can a technology be said to be truly proven.”





LX CHAIN HOIST : power and durability

Most of our lifting and transportation solutions for light loads are powered by the Street LX electric chain hoist which provides precision lifting and durability at surprisingly attractive prices.

The LX hoist is designed to meet the need for ultra efficient lifting and material handling in today's competitive world.

This new generation hoisting technology is based on a highly modular and versatile concept with a huge number of hoist and trolley constructions.

The LX range is available in capacities from 125kg up to 5 tonne in almost every world supply voltage with single and dual speed options. Hoists are available in standard headroom construction or low headroom with chain diverter. LX hoists are designed for applications with eye suspension or powered, push, or hand geared trolley. All capacities are available at M5 (FEM 2m) with a wide variety of hoist speeds. All standard models are manufactured with rated capacities in metric tonnes or U.S. tons.

“A hoist for tomorrow's world in which, only the most productive will prosper.”



Hoist motor

- Powerful 3 phase motor
- Improved ventilation to protect against overheating
- Single or dual speed
- Class "F" insulation
- I.P 55 protection
- 50 Hz solutions
- Available in almost every world supply voltage



Hoist brake

- Heavy duty long life hoist disc brake
- Low maintenance
- High efficiency
- Asbestos free linings
- Easy adjustment



CNC Machined Hoist Gearbox

- High performance low noise
- Hardened and heat treated gears
- Compact design
- Operates efficiently from -20 to +50°C (-4 to 122°F)

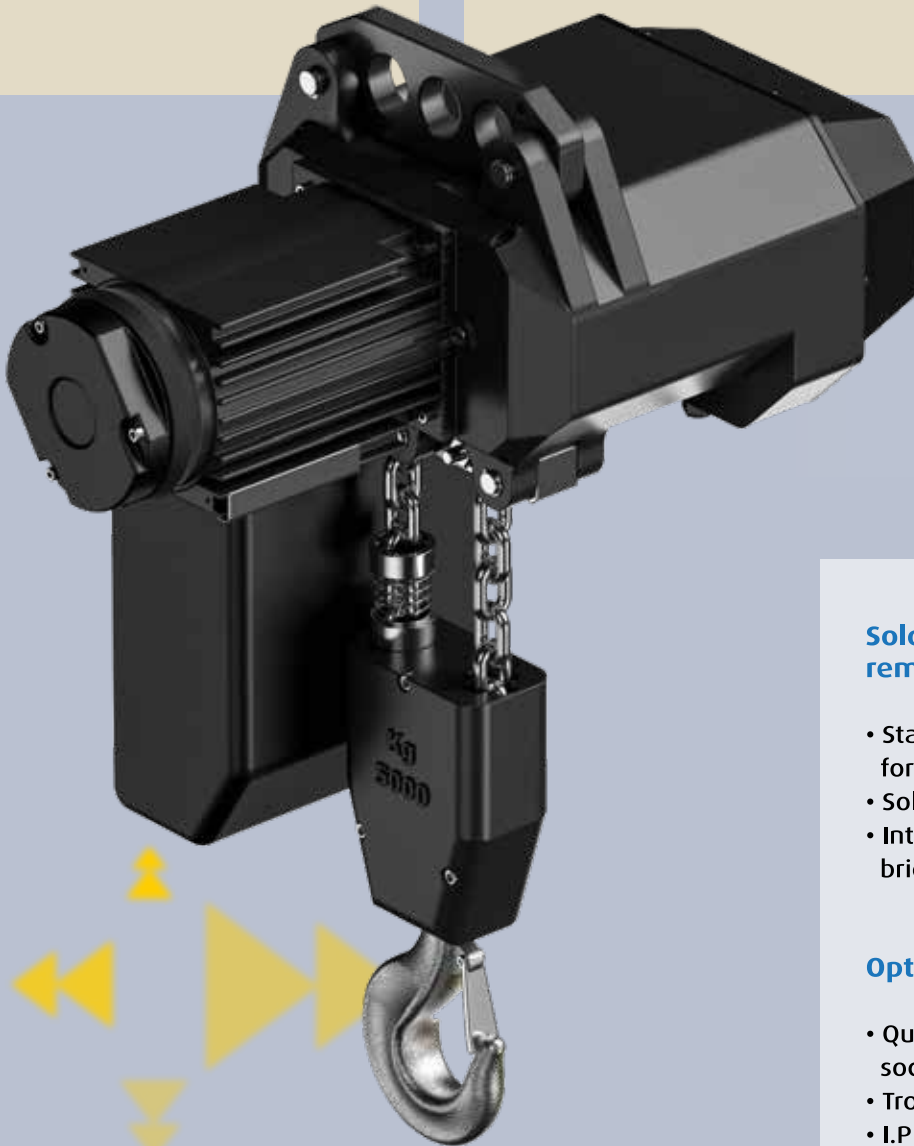

Solo or integrated, pendant or remote control

- Standard 48 Volt push-button pendant for solo hoists
- Solo radio remote control
- Integrated pendant or remote radio for bridge crane and jib solutions

Optional equipment and specifications

- Quick release electrics with plug and sockets for crane applications
- Trolley limit switch
- I.P 65 electrical enclosures
- 60 Hz solutions
- Single phase 230v and 110v solutions.
- Inverter on trolley motion



Overload protection/ hoist and lower limit switches

- Friction type torque limiting slipping clutch
- Prevents over hoisting and over lowering
- Easy adjustment
- Prevents operator overloading the hoist
- Effective protection of the hoist motor



Durable chain, drive sprocket and guide

- High accuracy CNC machined drive sprocket
- Geometrically precise chain
- High tensile zinc coated
- High resistance to wear and corrosion
- Precision calibrated chain guide



Chain collection

- Compact durable chain collection container
- Various sizes depending on chain length

LX HOIST

LX CHAIN HOIST :

impressive range of standard safety and operating features plus optional equipment.



LX

series



LX EYE SUSPENSION HOIST

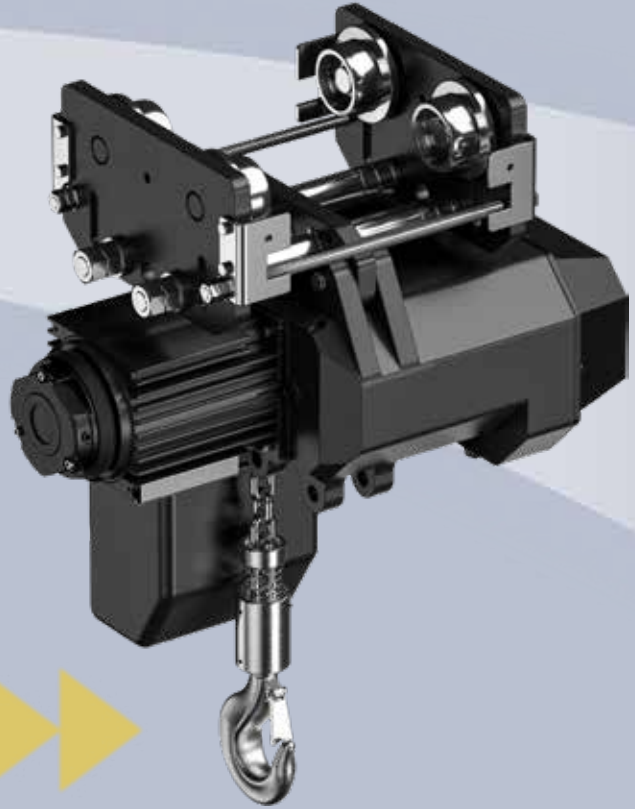

LX STANDARD HEADROOM HOIST WITH PUSH TROLLEY

Standard or low headroom construction

The **Street LX chain hoist** is one of the most comprehensive ranges of electric chain hoist in the market with global distribution. All models and capacities are available in standard headroom construction with a range of adjustable powered or push trolleys. These are designed for monorail or single beam applications such as bridge cranes or jib cranes but twin beam solutions are also possible.

Additionally eye suspension models for stationary hoist applications or applications with suspension trolley such as light crane and profile track systems are included in the range.

Standard headroom and eye suspension models optimise side hook approaches but for those applications where upper hook position is critical in a restricted roof height



Lifting hook

- DIN standard hook with safety catch
- Spring loaded safety catch fitted as standard

chain hoists

capacities up to 5 tonnes



**LX STANDARD HEADROOM HOIST
WITH POWERED TROLLEY**

**LX LOW HEADROOM HOIST
WITH POWER TROLLEY**

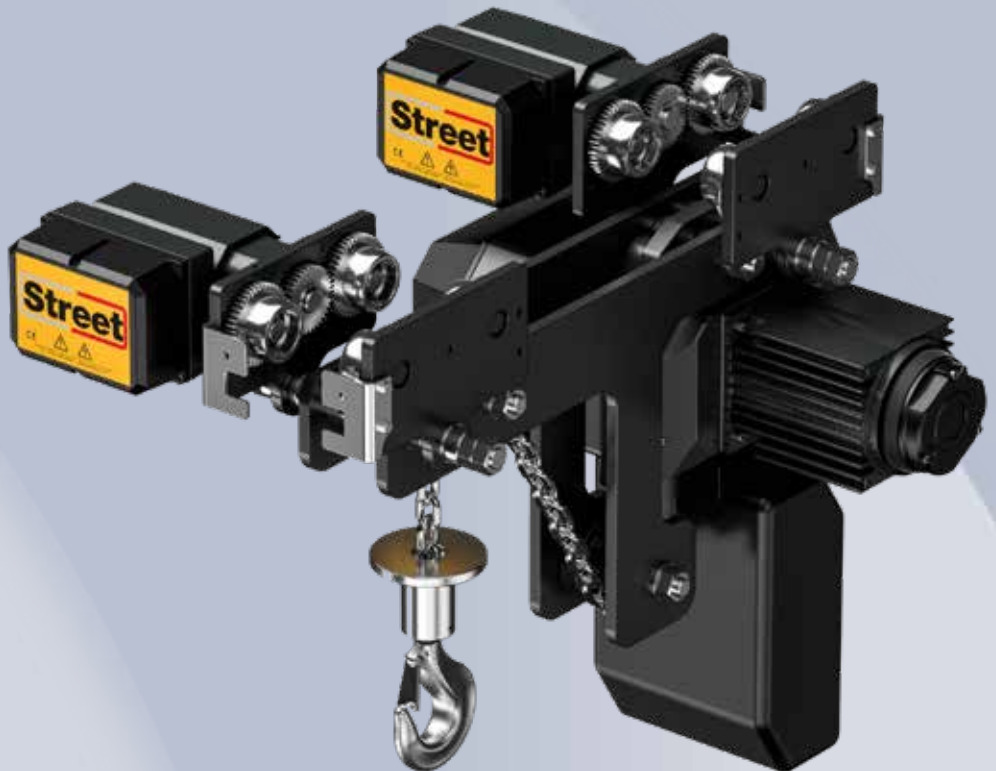

The Street low headroom hoist with chain diverter trolley provides an unbeatable compact solution.

Finish

- Durable polyurethane powder coating

● LX CHAIN HOIST DIMENSIONS

● PLAIN TROLLEY

- **MODEL** : LX011 PLAIN TROLLEY
- **Capacity** : 0.125 Tonne
- : 0.250 Tonne
- : 0.500 Tonne
- : 1.000 Tonne

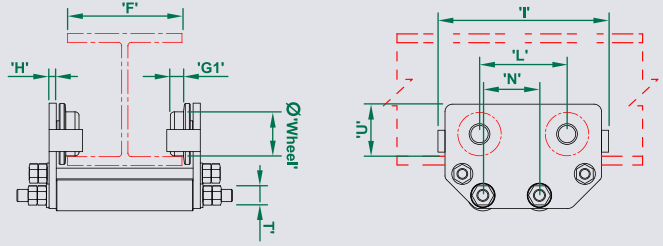
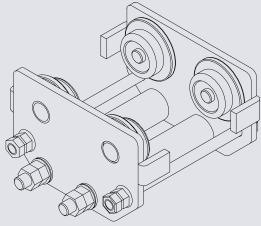

Steel Crane Model	Capacity (Tonne)	F1 min mm	F1 max mm	G1 mm	I mm	L mm	N mm	H mm	T mm	U mm	Wheel Ø	Weight (kg.)
LX011.125.PUSH TROLLEY	0.125	46	160	15	196	100	65	8	14	60	50	33
LX011.250.PUSH TROLLEY	0.250	46	160	15	196	100	65	8	14	60	50	33
LX011.500.PUSH TROLLEY	0.500	46	160	15	196	100	65	12	14	60	50	41
LX011.1000.PUSH TROLLEY	1.000	73	160	29	284	162	73	12	18	90	70	57

● MOTOR TROLLEY

- **MODEL** : LX011, 031, 032 MOTOR TROLLEY
- **Capacity** : 0.125 Tonne
- : 0.250 Tonne
- : 0.500 Tonne
- : 1.000 Tonne
- : 2.000 Tonne
- : 3.200 Tonne
- : 5.000 Tonne

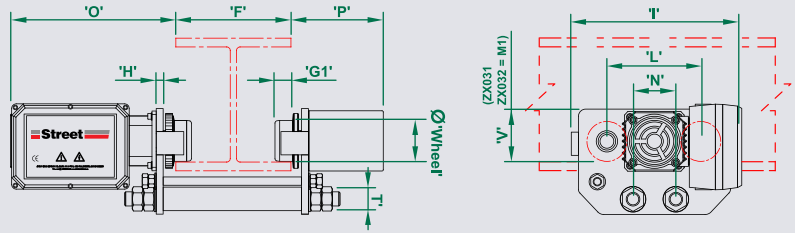
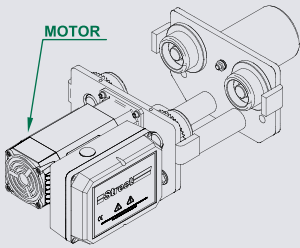

Steel Crane Model	Capacity (Tonne)	F1 min mm	F1 max mm	G1 mm	H mm	I mm	L mm	M1 mm	N mm	O mm	P mm	T mm	V mm	Wheel Ø	Weight (kg.)
LX011.125.MOTOR TROLLEY	0.125	64	200	24	12	289	158	-	65	279	156	14	88	65	57
LX011.250.MOTOR TROLLEY	0.250	64	200	24	12	289	158	-	65	279	165	14	88	65	57
LX011.500.MOTOR TROLLEY	0.500	64	200	24	12	289	158	-	65	279	156	14	88	65	65
LX011.1000.MOTOR TROLLEY	1.000	73	200	30	12	284	162	-	73	280	155	18	90	70	74
LX031.2000.MOTOR TROLLEY	2.000	200	300	30	12	284	162	95	-	282	157	-	-	70	115
LX032.3200.MOTOR TROLLEY	3.200	200	300	34	12	320	176	95	-	318	167	-	-	80	140
LX032.5000.MOTOR TROLLEY	5.000	200	300	34	12	284	162	95	-	318	167	-	-	80	158

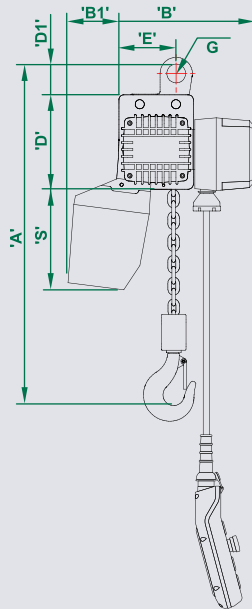
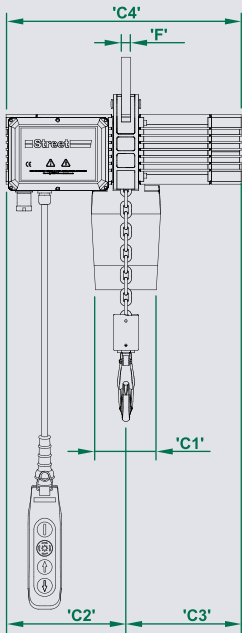

EYE SUSPENSION

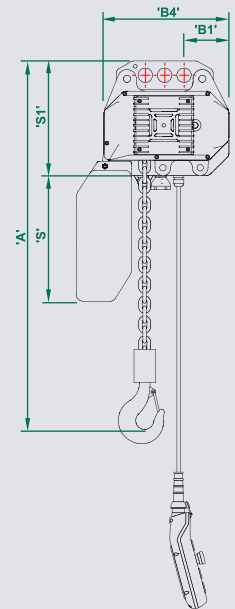
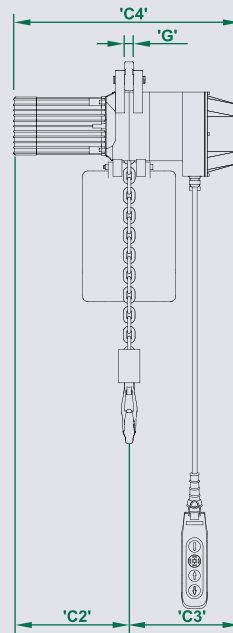

EYE SUSPENSION

● EYE SUSPENSION HOIST

- **MODEL** : LX011 EYE SUSPENSION
- **Capacity** : 0.125 Tonne
- : 1.000 Tonne

- **MODEL** : LX031, 032 EYE SUSPENSION
- **Capacity** : 2.000 Tonne
- : 3.200 Tonne
- : 5.000 Tonne

Steel Crane Model	Capacity (Tonne)	A mm	B1 mm	B2 mm	C1 mm	C2 mm	C3 mm	C4 mm	D mm	D1 mm	E mm	F mm	G mm	S mm	S1 mm
LX011.125.EYE SUSPENSION	0.125	355	256	96	154	230	200	430	174	36	104	12	31	164	-
LX011.250.EYE SUSPENSION	0.250	355	256	96	154	230	200	430	174	36	104	12	31	164	-
LX011.500.EYE SUSPENSION	0.500	355	256	96	154	230	200	430	174	36	104	12	31	164	-
LX011.1000.EYE SUSPENSION	1.000	355	256	96	154	230	200	430	174	36	104	12	31	164	-
LX031.2000.EYE SUSPENSION	2.000	466	132	73	-	310	350	660	168	-	-	-	25	293	230
LX032.3200.EYE SUSPENSION	3.200	670	125	54	-	353	305	657	236	-	-	-	25	353	301
LX032.5000.EYE SUSPENSION	5.000	685	125	54	-	353	335	687	236	-	-	-	25	353	301

● LX STANDARD HEADROOM HOIST WITH POWER TROLLEY SPECIFICATION

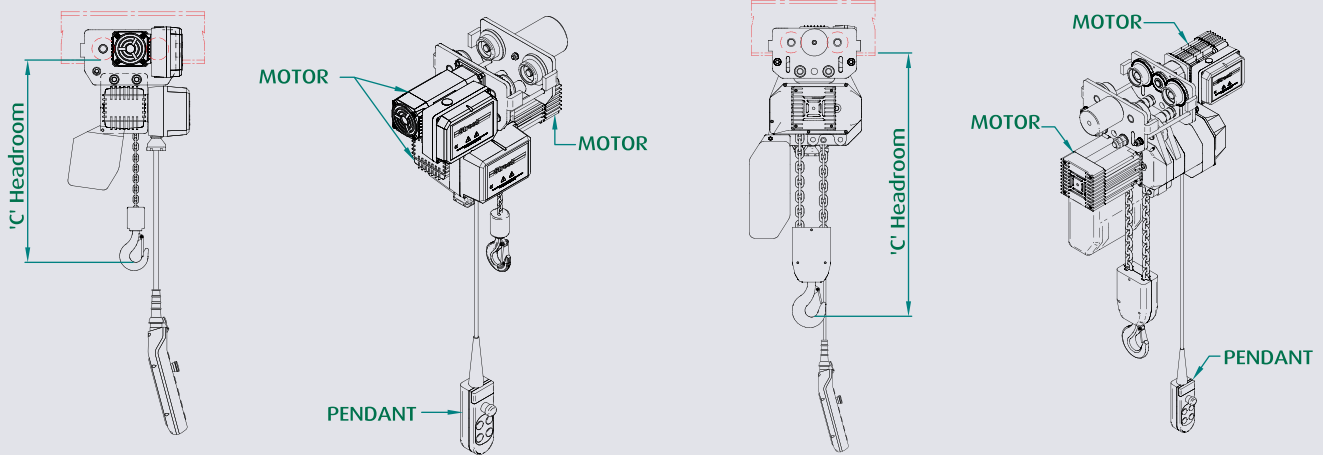

	Hoist Model Reference	S.W.L. (Tonne)	Duty		Lifting Height m.	Hoist		Chain		Traverse		C Hook	Weight (kg.)
			BS	FEM		2 Speeds (m/min)	Motor (kw.)	Dia (mm.)	Reeving	2 Speeds (m/min)	Motor (kw.)		
LX011	LX011.125.EYE SUSPENSION	0.125	M5	2m	6	4/1	0.5/0.2	4	1 : 1	-	-	355	27
	LX011.125.PUSH TROLLEY	0.125	M5	2m	6	4/1	0.5/0.2	4	1 : 1	-	-	467	33
	LX011.125.MOTOR TROLLEY	0.125	M5	2m	6	4/1	0.5/0.2	4	1 : 1	7/14	0.1/0.2	375	57
	LX011.125.LOW HEADROOM	0.125	M5	2m	6	4/1	0.5/0.2	4	1 : 1	7/14	0.1/0.2	299	61
	LX011.250.EYE SUSPENSION	0.250	M5	2m	6	4/1	0.5/0.2	4	1 : 1	-	-	355	27
	LX011.250.PUSH TROLLEY	0.250	M5	2m	6	4/1	0.5/0.2	4	1 : 1	-	-	467	33
	LX011.250.MOTOR TROLLEY	0.250	M5	2m	6	4/1	0.5/0.2	4	1 : 1	7/14	0.1/0.2	375	57
	LX011.250.LOW HEADROOM	0.250	M5	2m	6	4/1	0.5/0.2	4	1 : 1	7/14	0.1/0.2	299	63
	LX011.500.EYE SUSPENSION	0.500	M5	2m	6	4/1	1.0/0.25	5	1 : 1	-	-	380	35
	LX011.500.PUSH TROLLEY	0.500	M5	2m	6	4/1	1.0/0.25	5	1 : 1	-	-	586	41
	LX011.500.MOTOR TROLLEY	0.500	M5	2m	6	4/1	1.0/0.25	5	1 : 1	7/14	0.1/0.2	400	65
	LX011.500.LOW HEADROOM	0.500	M5	2m	6	4/1	1.0/0.25	5	1 : 1	7/14	0.1/0.2	307	66
LX011	LX011.1000.EYE SUSPENSION	1.000	M5	2m	6	4/1	1.8/0.4	7	1 : 1	-	-	445	44
	LX011.1000.PUSH TROLLEY	1.000	M5	2m	6	4/1	1.8/0.4	7	1 : 1	-	-	670	57
	LX011.1000.MOTOR TROLLEY	1.000	M5	2m	6	4/1	1.8/0.4	7	1 : 1	7/14	0.1/0.2	440	74
	LX011.1000.LOW HEADROOM	1.000	M5	2m	6	4/1	1.8/0.4	7	1 : 1	7/14	0.1/0.2	312	89
LX031	LX031.2000.EYE SUSPENSION	2.000	M5	2m	6	4/1	2.0/0.5	10	1 : 1	-	-	466	90
	LX031.2000.PUSH TROLLEY	2.000	M5	2m	6	4/1	2.0/0.5	10	1 : 1	-	-	685	113
	LX031.2000.MOTOR TROLLEY	2.000	M5	2m	6	4/1	2.0/0.5	10	1 : 1	7/14	0.1/0.2	685	115
	LX031.2000.LOW HEADROOM	2.000	M5	2m	6	4/1	2.0/0.5	10	1 : 1	7/14	0.1/0.2	388	126
LX032	LX032.3200.EYE SUSPENSION	3.200	M5	2m	6	4/1	3.0/0.7	10	2 : 1	-	-	670	113
	LX032.3200.PUSH TROLLEY	3.200	M5	2m	6	4/1	3.0/0.7	10	2 : 1	-	-	715	143
	LX032.3200.MOTOR TROLLEY	3.200	M5	2m	6	4/1	3.0/0.7	11	2 : 1	7/14	0.1/0.2	715	140
	LX032.3200.LOW HEADROOM	3.200	M5	2m	6	4/1	3.0/0.7	11	2 : 1	7/14	0.1/0.2	495	155
	LX032.5000.EYE SUSPENSION	5.000	M5	2m	6	4/1	3.5/0.8	11	2 : 1	-	-	685	123
	LX032.5000.PUSH TROLLEY	5.000	M5	2m	6	4/1	3.5/0.8	11	2 : 1	-	-	735	153
LX032.5000.MOTOR TROLLEY	5.000	M5	2m	6	4/1	3.5/0.8	11	2 : 1	7/14	0.1/0.2	735	158	
LX032.5000.LOW HEADROOM	5.000	M5	2m	6	4/1	3.5/0.8	11	2 : 1	7/14	0.1/0.2	505	163	

** Remark : Excerpt from our product portfolio. Above are standard model, Special specification is available for buyer, Please contact Distributor.

LX Chain Hoist Features features Include The Following :

- 400V (+/-10%) 3ph / 50Hz , - 48V Control voltage
- Suitable for indoor use with temperature range of -20C to + 50C at an altitude less than 1000m above sea level and in an atmosphere of normal humidity (5-95% non condensing) free of contamination and harmful deposits.
- Standard for 6m height of lift complete with chain bucket. Where greater height of lift is required use price/metre add-on up to max. 10m height of lift. Add on price includes larger chain bucket to suit height of lift specified up to max.
- Load Limiting device (rated capacity limiter) by means of a slipping clutch
- Hoist's upper and lower limit switches to use the micro swithes that operate on the auxiliary circuit of the hoist contactors cutting out operating contactor in the direction of lift.
- Fully sealed compact hoist gearbox - oil bath lubricated. In line hardened & treated helical gears for smooth & smooth & quiet operation
- Eegonmic hook forging to DIN15401 fitted with spring operated safety catch
- High tensile galvanised load chain
- Finish - RAL 7021 black grey

Classification of Mechanisms

FEM 9.511	1D _m	1C _m	1B _m	1A _m	2 _m	3 _m	4 _m	5 _m
BS 2573 P2	M1	M2	M3	M4	M5	M6	M7	M8
Hoist	Intermittent ratio (R1%)		25	30	40	50	60	>60
	No. of starts per hour (S/h)		150	180	240	300	360	>360
	No. of cycles per hours (C/h)		25	30	40	50	60	>60
Trolley	Intermittent ratio (R1%)		20	25	30	40	50	60
	No. of starts per hour (S/h)		120	150	180	240	300	360
	No. of cycles per hours (C/h)		20	25	30	40	50	60
Two-Speed Double polarity motor								
No. of starts per hour (S/h)		Main speed	1/3 (33.3% of total starts per hour)					
		Slow speed	2/3 (66.7% of total starts per hour)					
Operating time per day		Main speed	2/3 (66.7% of average operating time per day)					
		Slow speed	1/3 (33.3% of average operating time per day)					
Used in temporary duty	Operating time at main speed (min.)		15	15	30	30	60	>60
	Operating time at slow speed (min.)		2.5	3	3.5	4	5	6
	Maximum number of starts per hour (s/h)		10	10	10	10	10	10

For applying to the hoist mechanisms are classified into the groups depending on operating conditions. The group into which a mechanism is classified is determined by the following factor :

- Class of operating time
- Load spectrum

Class of operating time

The class of operating time indicates the average period per day during which a mechanism is in operation (see table 1). A mechanism is considered to be in operation when it is in motion.

For mechanisms not regularly used during the year the average operating time per day is determined by the ratio of the annual operating time to 250 working days per year.

The higher classes of operating time apply only in such cases where a mechanism is operated during more than one shift per day.

Table 1

Average operating time per day (hours)

$$\text{Operating time/day (h)} = \frac{2 \times \text{lifting height (m)} \times \text{number of cycles per hour} \times \text{working time/day (h)}}{60 \text{ (minutes per hour)} \times \text{lifting speed (m/min)}}$$

Lifting height = The average hook travel under actual operating conditions (meter)

Cycles per hour = The average number of complete ascent/decent operations in an hour

Working time/day = The time during which the hoist is used on a working day (hour)

Lifting speed = The average lifting speed (normally the maximum lifting speed) at which the load cycles are performed. (Meter per minute)

Class of operating time		Average operating time per day (hours)	Calculated total operating time (hours)
FEM	BS		
V0.06	T0	≤ 0.12	200
V0.12	T1	≤ 0.25	400
V0.25	T2	≤ 0.5	800
V0.5	T3	≤ 1	1600
V1	T4	≤ 2	3200
V2	T5	≤ 4	6300
V3	T6	≤ 8	12500
V4	T7	≤ 16	25000
V5	T8	≤ 16	50000

Load spectrum

The load spectrum indicates to what extent a mechanism or part thereof is subject to maximum stress or whether it is subject to smaller load only.

Table 2

For an exact classification into groups the cubic mean value k referred to the safe working load is required. It is calculated by using the following formula :

$$k = \sqrt[3]{(\beta_1 + \gamma)^3 \cdot t_1 + (\beta_2 + \gamma)^3 \cdot t_2 + \dots + \gamma^3 \cdot t_{\Delta}}$$

Where :

$$\beta = \frac{\text{useful or partial load}}{\text{safe working load}}$$

$$\gamma = \frac{\text{dead load}}{\text{safe working load}}$$

$$t = \frac{\text{operating time under useful or partial load and dead load}}{\text{total operating time}}$$

$$t_{\Delta} = \frac{\text{operating time under dead load only}}{\text{total operating time}}$$

Four load spectrum are distinguished which are determined by the definitions given and by the ranges covered by the cubic mean values k as listed in table 2

Load spectrum		Definitions	Cubic mean value
FEM	BS		
1 (light)	L1	Mechanisms or parts thereof, Usually subject to very small Loads and in exceptional cases Only to maximum loads	<p>$k \leq 0.50$</p>
2 (medium)	L2	Mechanisms or parts thereof, Usually subject to small loads But rather often to maximum loads	<p>$0.50 < k \leq 0.63$</p>
3 (heavy)	L3	Mechanisms or parts thereof, Usually subject to medium Loads but frequently to Maximum loads	<p>$0.63 < k \leq 0.80$</p>
4 (very heavy)	L4	Mechanisms or parts thereof, Usually subject to maximum or almost maximum loads	<p>$0.80 < k \leq 1.00$</p>

The formular given above for the cubic mean value k excludes the weight of the load carrying means. This is acceptable if the ratio

$$\frac{\text{Weight of the load carrying means}}{\text{safe working load}} \leq 0.05$$

By applying The Classes of operating times and The Load Spectrum, The Mechanisms are classified into 8 groups :

Table 3
Classification of Mechanisms into 8 groups

Load spectrum			Class of operation time								
			V 0.06	V 0.12	V 0.25	V 0.5	V 1	V 2	V 3	V 4	V 5
			T 0	T 1	T 2	T 3	T 4	T 5	T 6	T 7	T 8
			Average operating time per day in hours								
FEM	BS	Cubic mean value	≤ 0.12	≤ 0.25	≤ 0.5	≤ 1	≤ 2	≤ 4	≤ 8	≤ 16	≤ 16
1 (Light)	L1	$k \leq 0.50$			1 D _m	1 C _m	1 B _m	1 A _m	2 _m	3 _m	4 _m
					M1	M2	M3	M4	M5	M6	M7
2 (medium)	L2	$0.50 < k \leq 0.63$		1 D _m	1 C _m	1 B _m	1 A _m	2 _m	3 _m	4 _m	5 _m
				M1	M2	M3	M4	M5	M6	M7	M8
3 (heavy)	L3	$0.63 < k \leq 0.80$	1 D _m	1 C _m	1 B _m	1 A _m	2 _m	3 _m	4 _m	5 _m	
			M1	M2	M3	M4	M5	M6	M7	M8	
4 (very heavy)	L4	$0.80 < k \leq 1.00$	1 C _m	1 B _m	1 A _m	2 _m	3 _m	4 _m	5 _m		
			M2	M3	M4	M5	M6	M7	M8		

The result of the classification of mechanism into groups according to table 3 is that the same life, expressed in years, may be expected for these machines under all load spectrum and average operating times per day. This applies on condition that the life of the individual component depends on the third power of the load.

The average daily operating time with in the classes of operating times are doubled as follows:

1. Within a group by passing into a lower load spectrum (progression 1.25), because $1.25^3 = 2$.
2. Within a load spectrum by passing into a higher group and derating the SWL by the factor of 1.25, because $1.25^3 = 2$.

LX Chain Hoist Applications : Street 'bridge crane'



Street LX chain hoists are designed and built to give reliability and endurance in a wide range of industrial applications such as manufacturing, service and maintenance but our customers and distributors continually surprise us with new and innovative ways to use our products. We therefore have installations in sports, entertainment, scientific and military applications. For bespoke applications with curved monorail beams, the standard LX is suitable for a min. 900mm radius.





LX Chain Hoist Applications : Street slewing jib crane

LX HOISTS : Robust construction Long service life

Street LX chain hoists are designed and built to give reliability and endurance in a wide range of industrial applications such as manufacturing, service and maintenance but our customers and distributors continually surprise us with new and innovative ways to use our products. We therefore have installations in sports, entertainment, scientific and military applications.



The LX chain hoist is the smallest member of a successful family of Street hoists. The Street electric wire rope hoists are available in capacities up to 200t. LX is the product of meticulous research and development using advanced design methods including the latest solid modelling and finite element analysis.



Street 'LCS profile' crane



www.streetcrane.co.uk

Distributed By :

TITAN[®]



TITAN CRANE CO.,LTD.

1/19 Moo 1 Phimpha, Bangpakong, Chachoengsao 24130 Thailand.

Tel. 038 989 369-72 Fax. 038 989 368

E-mail : titancrane.info@gmail.com