



[www.kdhoist.com](http://www.kdhoist.com)

*Technology, Efficiency, Handiness  
All There are possible at KUK-DONG HOIST Co., Ltd.'s*

# **MINI ELECTRIC CHAIN HOIST**

MN-125/250(125/250kgs)

- Single Phase (220V)
- Mini Size & Weight (14kgs)
- Push Button (Easy to Use)
- Brushless DC Motor
- Speed Regulation Dial (2.0 ~ 14.0 M/MIN.)
- Mechanical Brake & Slip Clutch
- High Tension Load Chain (4.0mm)



**A+Time**  
**MN250**  
**KUKDONG HOIST**  
MADE IN KOREA  
Rated Load 250kg  
Holding speed max. 15m/min  
Motor 5LDC750W



# MINI Electric Chain Hoist Exploded View

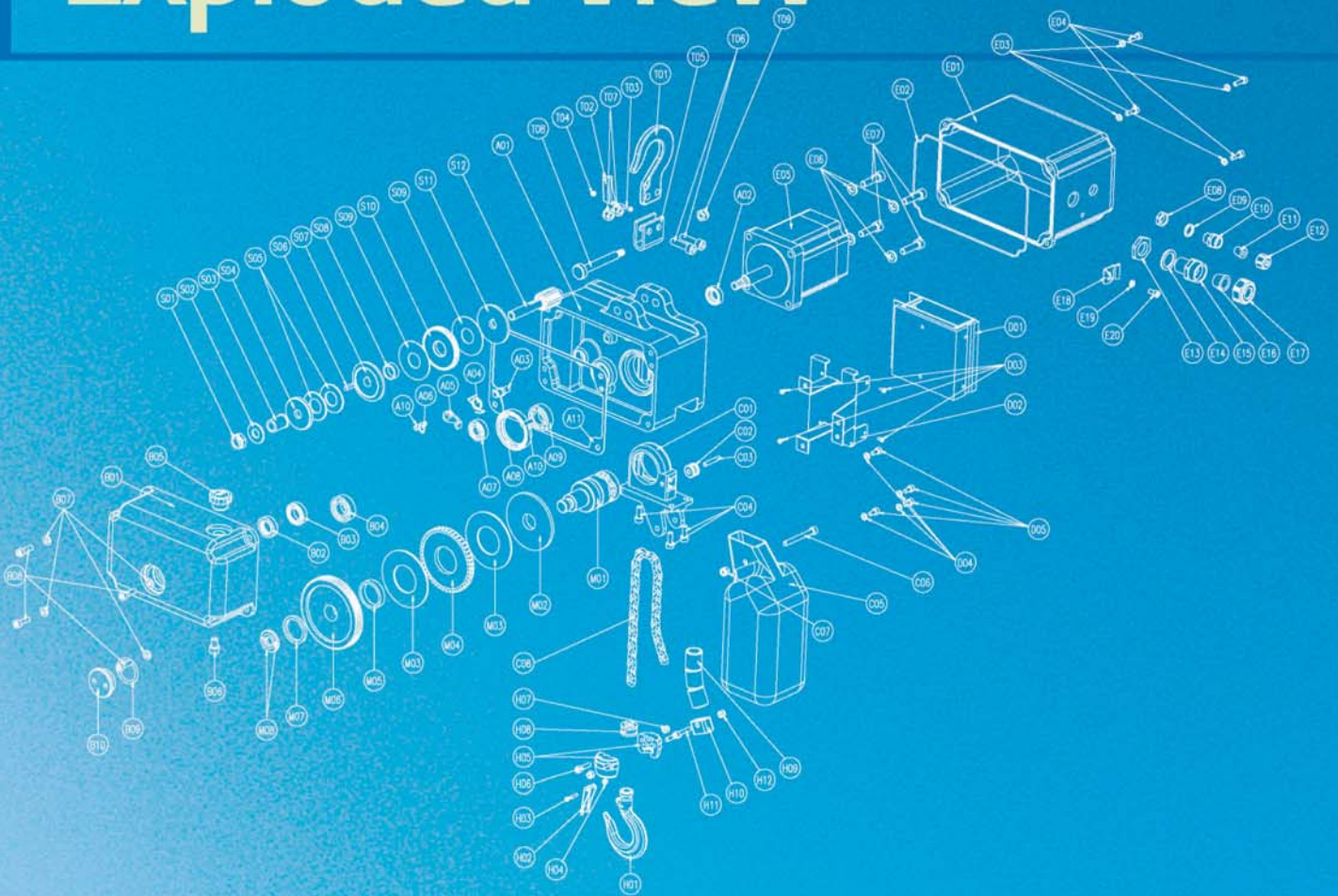

### SLIP CLUTCH PART

NO	DESCRIPTION	MATERIAL	QTY	SIZE	REMARK
S01	LOCK NUT	PURL	1	M12	
S02	TONGUE CONTROL WASHER	SS41	1	T2x1.2x#25	
S03	SLIDE	S43C	1	#12x#18.3x23L	
S04	SPRING GUIDE	S43C	1	#4.5x7.3x2L	
S05	CONICAL SPRING	PURL	2	#40x#20.4x2.75H	
S06	KEY	PURL	1	28 4x4x1.8	
S07	PRESSURE PLATE B	SS41	1	T12x#14x#12	
S08	BLANK	8C3	1	#3.1x#1.7x1/2	
S09	LINK	PAPER	2	T1x#0.5x#21	for PINCH GEAR
S10	PINCH GEAR	S43C	1	T7x#3.9 8x#21	
S11	PRESSURE PLATE A	SS41	1	T7x#5.4x#12	
S12	2nd. PINCH	SCM15	1	#5K.1497.5	

### MECHANICAL BRAKE & LOAD SHEAVE PART

NO	DESCRIPTION	MATERIAL	QTY	SIZE	REMARK
M01	LOAD BEARING	S43C	1	#4x2#10x#4	
M02	PRESSURE PLATE C	SS41	1	T7x#1.00x#22	
M03	LINK	W0308	2	25x#0.8x3	
M04	INVERT GEAR	S43C	2	25x#0.8x#1	
M05	BLANK	8C3	1	#3.8x#1.8x#1.6	
M06	LOAD GEAR	S43C	1	#10x#20x#31.25	
M07	COVER RING	SCQ21	1	23.4x#26.1x#30.9	
M08	COVER	SCQ21	2	14.3x#30x#12	

### CHAIN GUIDE PART

NO	DESCRIPTION	MATERIAL	QTY	SIZE	REMARK
C01	CHAIN GUIDE	FC24S	1	#4	
C02	CHAIN STOP HOLDER	SCQ21	1	#17x15	
C03	CHAIN STOP HOLDER PIN	SCQ21	1	#5x30L	
C04	SOCKET HEAD CAP BOLT	PURL	3	M5x15	with S/W
C05	CHAIN BLOCK	PLASTIC	1	30x#20x18.5L	LIFT. Min. 5m
C06	SOCKET HEAD CAP BOLT	PURL	1	M5x55	
C07	LOCK NUT	PURL	1	M5	
C08	LOAD CHAIN	AV1582A	-	#4x15	

### PUSH BUTTON PART

NO	DESCRIPTION	MATERIAL	QTY	SIZE	REMARK
P01	PUSH BUTTON	PURL	1		
P02	CONTROL CABLE	VOT	1	0.750x#C	
P03	LAMP-2821B	PURL	1	LED 1 #5	
P04	LAMP-180	PURL	1	LED 1 #5	
P05	SPEED CONTROL SWITCH	PURL	1	10K	W/SLAKE MICROSWICH
P06	BUTTON-UP	PURL	1		
P07	BUTTON-DOWN	PURL	1		
P08	POWER CABLE	PURL	1	AC 1# 110/220V	

### MAIN BODY PART

NO	DESCRIPTION	MATERIAL	QTY	SIZE	REMARK
A01	MAIN BODY	AC28	1	250kg	ET 1.2.788kg
A02	DR. RETAINER	PURL	1	#15x#25x7	
A03	PINN. PIN	S43C	1	#6.11x#11.3x26L	
A04	PINN. SPRING	SWS	1	#1.2x3	
A05	PINN.	S43C	1		
A06	SWAY RING	PURL	1	#8	17#-32
A07	BALL BEARING	PURL	1	#12x#25x8	60012a
A08	DR. RETAINER	PURL	1	#4.2x#5.5x8	
A09	BALL BEARING	PURL	1	#17x#35x10	60032a
A10	SPRING PIN	PURL	2	#6x20	
A11	SHOET	W#4895	1	T1x204.6x127.8	for SHAW CASE

### REDUCER CASE PART

NO	DESCRIPTION	MATERIAL	QTY	SIZE	REMARK
R01	REDUCER CASE	AC28	1	250kg	ET 1.1.814kg
R02	DR. RETAINER	PURL	1	#17x#25x7	
R03	BALL BEARING	PURL	1	#17x#35x7	60032a
R04	BALL BEARING	PURL	1	#17x#35x10	60032a
R05	DR. CAP	PURL	1	PT-1/2	
R06	DR. BRINK BOLT	PURL	1	M5x10	PLASTIC
R07	SPRING LOCK WASHER	PURL	4	M5	
R08	SOCKET HEAD CAP BOLT	PURL	4	M5x20	
R09	S-RING	PURL	1	F26x5.5	for SHAW CONTROL OP
R10	TONGUE CONTROL CAP	S43C	1	#40x13.5	

### CONTROL PART

NO	DESCRIPTION	MATERIAL	QTY	SIZE	REMARK
Z01	CONTROL PART COVER	AC28	1	250kg	ET 1.1.244kg
Z02	S-RING	PURL	1	F #1.3x#5.0	for CONTROL part Cover
Z03	SPRING LOCK WASHER	PURL	4	M5	
Z04	SOCKET HEAD CAP BOLT	PURL	4	M5x15	
Z05	BLDC MOTOR	PURL	1	750W	
Z06	SPRING LOCK WASHER	PURL	4	M5	
Z07	SOCKET HEAD CAP BOLT	PURL	4	M5x30	
Z08	LOCK NUT	PURL	1	NEC-01-8A	
Z09	PACING	PURL	1	NEC-01-8A	
Z10	CABLE SLANG BODY	PURL	1	NEC-01-8A	
Z11	SLIDE	PURL	1	NEC-01-8A	
Z12	CABLE SLANG CAP	PURL	1	NEC-01-8A	
Z13	LOCK NUT	PURL	1	NEC-01-16A	
Z14	PACING	PURL	1	NEC-01-16A	
Z15	CABLE SLANG BODY	PURL	1	NEC-01-16A	
Z16	SLIDE	PURL	1	NEC-01-16A	
Z17	CABLE SLANG CAP	PURL	1	NEC-01-16A	
Z18	CABLE CLIP	SS41	1	M#250	
Z19	SPRING LOCK WASHER	PURL	1	M5	
Z20	SOCKET HEAD CAP BOLT	PURL	1	M5x10	

### TOP HOOK PART

NO	DESCRIPTION	MATERIAL	QTY	SIZE	REMARK
T01	TOP HOOK	S43C	1	250kg(125kg)	
T02	SAFETY LOCK	SS41	1	Small	
T03	PINN. HEAD SCREW	PURL	1	M3x20	
T04	LOCK NUT	PURL	1	M3	
T05	TOP WASHER	SS41	1	250kg(125kg)	
T06	SOCKET HEAD CAP BOLT	PURL	2	M5x30	
T07	TOP LOCK NUT	PURL	2	M5	
T08	TOP LOCK PIN	S43C	1	#20x#20L	
T09	LOCK NUT	PURL	1	M5	

### BOTTOM HOOK PART

NO	DESCRIPTION	MATERIAL	QTY	SIZE	REMARK
B01	BOTTOM HOOK	S43C	1	250kg(125kg)	
B02	SAFETY CLIP	SS41	1	Small	with SPRING
B03	PINN. HEAD SCREW	PURL	1	M3x20	
B04	LOCK NUT	PURL	1	M3	
B05	BOTTOM WASHER	S43C	1	250kg(125kg)	with C
B06	SOCKET HEAD CAP BOLT	PURL	2	M5x30	with C
B07	LOCK NUT	PURL	2	M5	
B08	SLIP CLUSION	URETHAN	1	#22x13.4	with SHAW WASHER
B09	CHAIN STOP HOLDER B	SCQ	2	#21.7x2.87x25L	
B10	CHAIN STOP HOLDER A	S43C	1	250kg(125kg)	with C
B11	SOCKET HEAD CAP BOLT	PURL	1	M5x30	
B12	LOCK NUT	PURL	1	M5	

### DRIVER(CONTROLLER) PART

NO	DESCRIPTION	MATERIAL	QTY	SIZE	REMARK
D01	BLDC DRIVER	-	1		
D02	DRIVER PLATE	SS41	1		with SHAW
D03	PINN. HEAD SCREW	PURL	4	M3x10	
D04	SPRING LOCK WASHER	PURL	4	M5	
D05	SOCKET HEAD CAP BOLT	PURL	4	M5x10	



# MINI Electric Chain Hoist MN/MNP Type



## MN Type

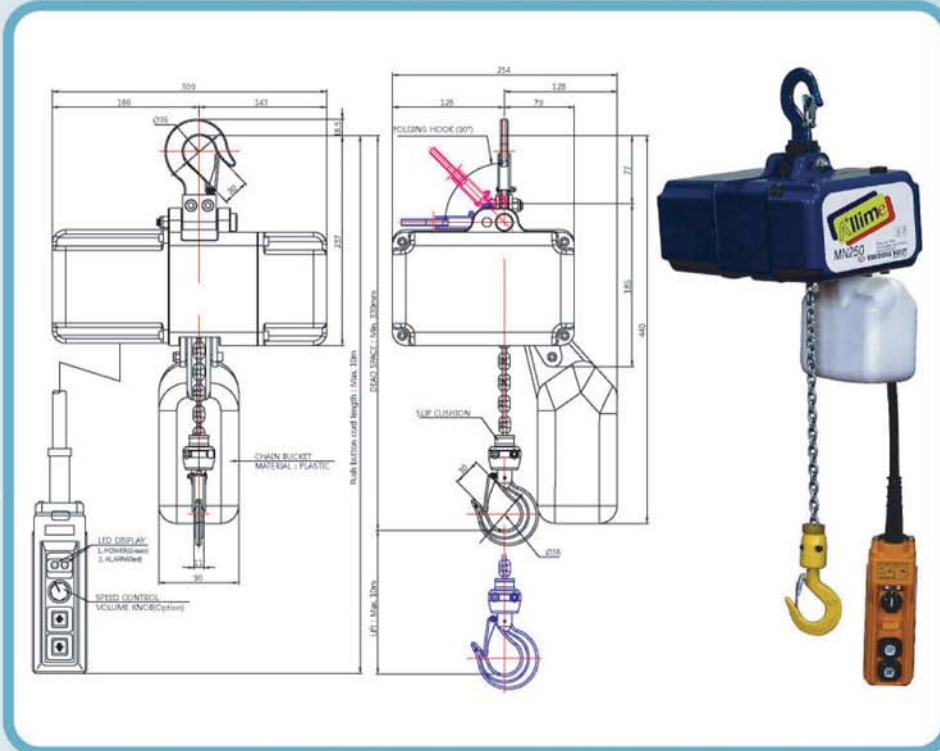

MODEL	MN-250	
CAPACITY	250 kg	
TEST LOAD	312 kg	
LIFT	Max. 10m	
HOISTING	MOTOR	BLDC 750w
	SPEED	12m/min
	SPEED CONTROL	0~15m/min(Variable:Option)
SAFETY DEVICE	MECHANICAL BRAKE & SUP CLUTCH	
POWER SOURCES	AC 1Ø 220V 50/60Hz	
OPERATION METHOD	PUSH BUTTON SWITCH TYPE ON FL	
LED DISPLAY	POWER(green) & ALARM(red)	
OPERATING TEMPERATURE	-20°C ~ 50°C	
International Protection	54	
LOAD CHAIN	Ø4.0 x P12.0mm x 1fall	
PAINT COLOR	0.4 PB 4.2/5.6	
NET WEIGHT	Max. 19 kg	

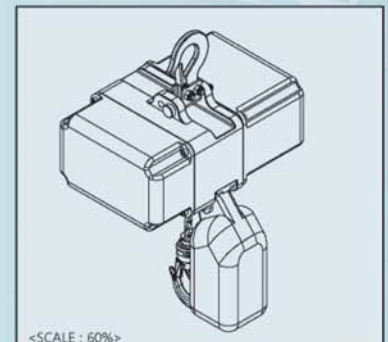

## MNP Type

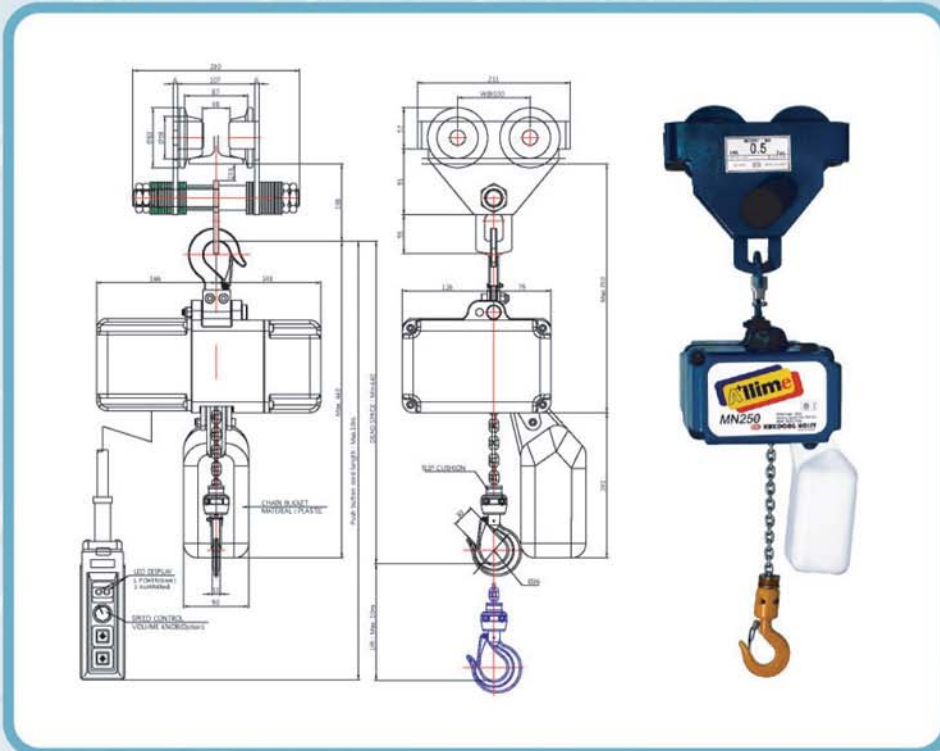

MODEL	MN-250	
CAPACITY	250 kg	
TEST LOAD	312 kg	
LIFT	Max. 10m	
HOISTING	MOTOR	BLDC 750w
	SPEED	12m/min
	SPEED CONTROL	0~15m/min(Variable:Option)
SAFETY DEVICE	MECHANICAL BRAKE & SUP CLUTCH	
POWER SOURCES	AC 1Ø 220V 50/60Hz	
OPERATION METHOD	PUSH BUTTON SWITCH TYPE ON FL	
LED DISPLAY	POWER(green) & ALARM(red)	
OPERATING TEMPERATURE	-20°C ~ 50°C	
International Protection	54	
LOAD CHAIN	Ø4.0 x P12.0mm x 1fall	
PAINT COLOR	0.4 PB 4.2/5.6	
NET WEIGHT	Max. 19 kg	

MODEL	KPT
CAPACITY	250 kg
I-BEAM WIDTH	75, 100, 125
Min. RADIUS of CURVE	900 mm
TEST LOAD	312 kg
NET WEIGHT	7 kg

※ Option : 가변형 권상속도  
(VARIABLE HOISTING SPEED)

# MINI Electric Chain Hoist

## BODY Assembly

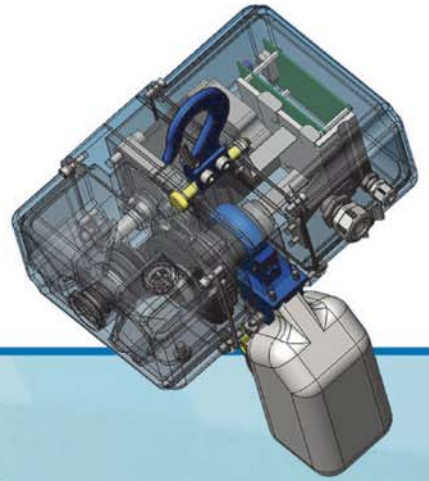

### PUSH Button

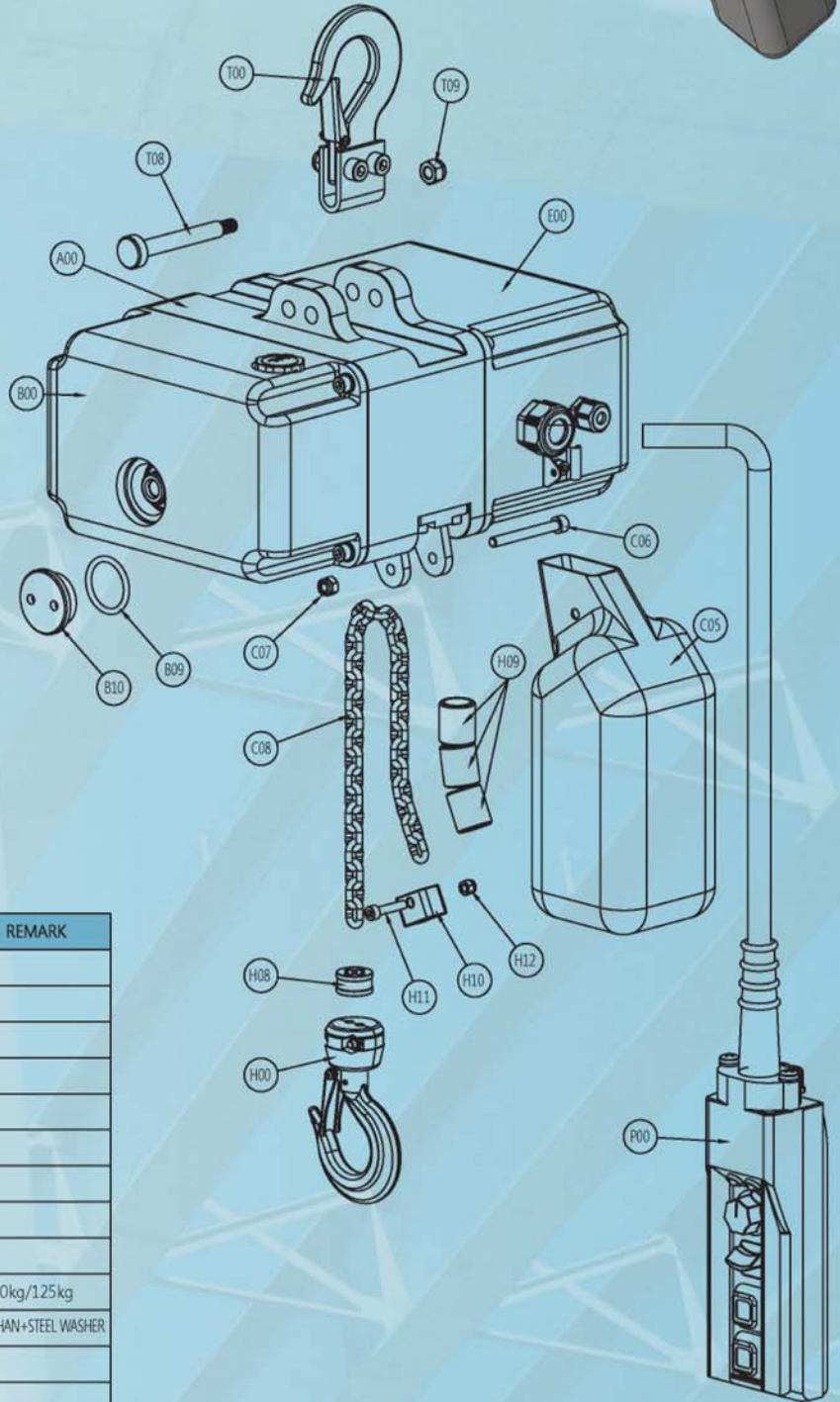
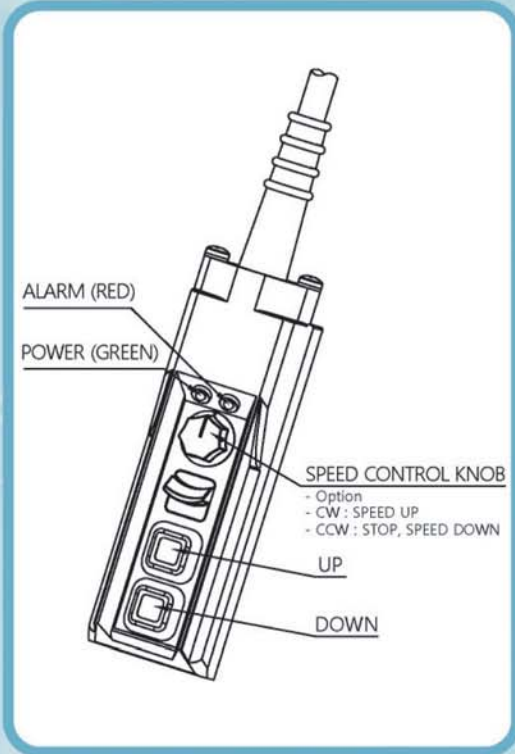

### BODY Assembly

NO	DESCRIPTION	MATERIAL	QTY	SIZE	REMARK
A00	MAIN BODY Sub Assy		1	MN-250	
B00	REDUCER CASE Sub Assy		1	MN-250	
B09	O-RING	PUR.	1	P28x3.5	
B10	TORQUE CONTROL CAP	S45C	1	Ø40x13.5	
C05	CHAIN BUCKET	PLASTIC	1	90x90x162L	
C06	SOCKET HEAD CAP BOLT	PUR.	1	M6x55	
C07	LOCK NUT	PUR.	1	M6	
C08	LOAD CHAIN	AISI15B24	-	Ø4x15	
E00	CONTROL PART Sub Assy		1	MN-250	
H00	BOTTOM HOOK Sub Assy		1	MN-250	250kg/125kg
H08	SLIP CUSHION	URETHAN	1	Ø22x12.4	URETHAN+STEEL WASHER
H09	CHAIN STOP HOLDER B	SGP	3	Ø21.7x2.6tx25L	
H10	CHAIN STOP HOLDER A	S45C	1	250kg(125kg)	
H11	SOCKET HEAD CAP BOLT	PUR.	1	M5x25	
H12	LOCK NUT	PUR.	1	M5	
T00	TOP HOOK Sub Assy		1	MN-250	250kg/125kg
T08	TOP HOOK PIN	S45C	1	Ø20x90L	
T09	LOCK NUT	PUR.	1	M8	
P00	PUSH BUTTON Sub Assy		1	MN-250	
OIL	GEAR OIL	PUR.	1	250cc	MEROPA 220



# MINI Electric Chain Hoist

# Example View

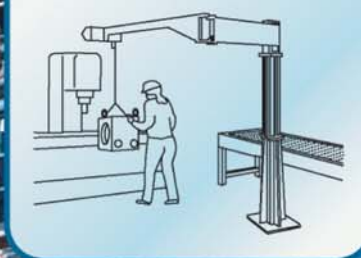
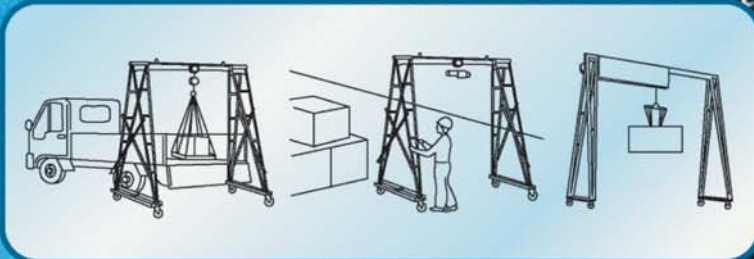
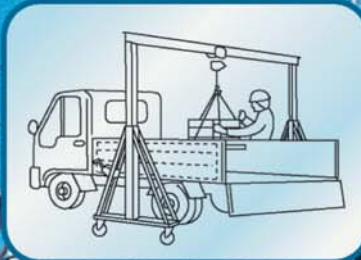
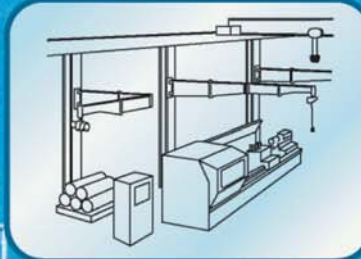
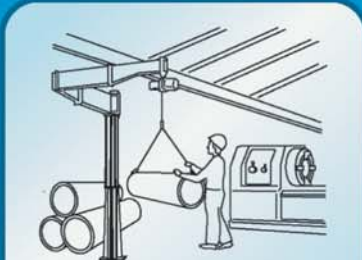
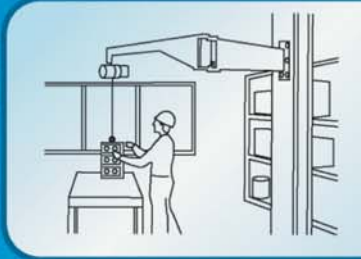
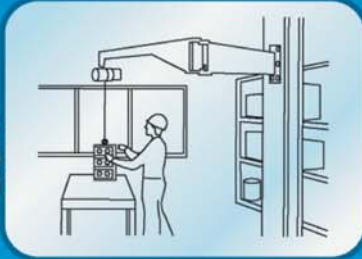



**Head Office & Factory**

630-2, Sunggok-dong, Danwon-Gu, Ansan-city, Kyunggi-do, KOREA  
T. 82-31-491-5311 F. 82-31-492-0473  
E-mail : kukdong@kdhoist.com

**Overseas DEPT.**

T. 82-2-783-4203 F. 82-2-784-6340  
E-mail : kukdong@kita.net

**A/S Office** 080-380-0001

**Home-page** <http://www.kdhoist.com>

