

# **TECHNICAL PROPOSAL**

FOR

## **REMOTE CONTROLLED SWITCHES**

**22 kV, 630 A, 12.5 kA**

**33 kV, 400 A, 12.5 kA**

**PRECISE**

**PRECISE ELECTRO-MECHANICAL WORKS CO., LTD.**

# CONTENTS

---

	Page	
1. Introduction		3
2. Standard		3
3. Service condition		3
4. Technical Requirement		3
5. Remote controlled switch operation		11
6. Minimum nameplate information		12
7. Test		13
8. Packing		13

## **1. Introduction**

### **1.1 General**

These remote controlled switches (RCS) are combined of a high voltage switch, line sensors (current transformers), a voltage transformer and power supply, a control cabinet with free space for remote terminal unit (RTU) and radio communication with antenna for the future. These RCS are suitable for outdoor installation in 22kV and 33kV 50 Hz distribution system. This technical proposal has provided the information of each product that is used.

The remote controlled switches and accessories are designed and constructed for mounting on concrete pole. Each set of the RCS is composed of the following equipment:

- (1) Three phase SF<sub>6</sub> gas load break switches (the switches),
- (2) Voltage sensor or Voltage transformer,
- (3) Current sensor or Current transformer,
- (4) Switch power supply (SPS),
- (5) Local control panel,
- (6) Distribution management system (DMS) interface and
- (7) Control cabinet.

## **2. Standard**

This specification covers the basic requirements of 22 kV and 33 kV 50 Hz remote controlled switch. The RCS could be operated by manual or electrical. In electrical operating, the local or remote mode could be selected for controlling. The offered remote controlled switch has been tested in accordance with IEC 265-1, IEC 694 and other following each product.

## **3. Service conditions**

The remote controlled switch is suitable for operation under the following conditions:

- Ambient air temperature : up to 40<sup>0</sup>C
- Relative humidity : up to 100%
- Altitude : up to 1,000 m above mean sea level
- Climatic condition : tropical climate

## **4. Technical requirement**

### **4.1 SF<sub>6</sub> Gas Load break switch**

These SF<sub>6</sub> high speed sectionalizing load break switch are designed, manufactured, and tested in accordance with the current IEC and NEMA standards. These switches are completely assembled, filled, and tested at the factory. The application of gas filled equipment requires some knowledge of the correct procedures for handling of SF<sub>6</sub> gas. The qualified personnel who install, operate and maintain the switches can find the information in this instruction.

#### 4.1.1 Design/Performance data

Descriptions	22 kV	33 kV
Manufacturer	PRECISE ELECTRO – MECHANICAL WORKS CO.,LTD	
Model / Type or Catalogue No.	ORAP 21–396–20MT	
Rated voltage (kV)	24	36
Rated frequency (Hz)	50	
Rated normal Current (A) (max.)	630	400
Rated symmetrical interrupting current (A)	630	
Rated short-time withstand current, 1 sec (kA r.m.s.)	12.5	
Rated short-circuit making current (kA peak)	31.5	
Rated power frequency withstand voltage, 1 min (kV r.m.s.)	50	70
Rated impulse withstand voltage (kV peak)	125	170
Rated mainly active load breaking capacity (A)	630	
Rated transformer off-load breaking capacity (A)	21	
Rated cable charging breaking capacity (A)	10	
Operating time at rated normal current (sec.)	≤ 2	
Maximum temperature of (K)		
- contacts	30	
- current carrying parts	30	
- mechanical parts	5	
Mechanical endurance, in number of operations	2,000 (Class M1)	
Number of operations at rated normal current Interruption	400 (Class E3)	
Rated pressure range of SF <sub>6</sub> gas (kgf/cm <sup>2</sup> )	1.2	
Pressure of SF <sub>6</sub> when locking device operates (kgf/cm <sup>2</sup> )	0.7	

Descriptions	22 kV	33 kV
Protection degree of assembled enclosure	IP 67	
Operation force of handle (kgf)	35 max.	
Conductor material of main circuit lead	Copper	
Cross section of main circuit lead (mm <sup>2</sup> )	≥ 200	≥ 120
Creepage distance of porcelain bushing (mm)	≥ 600	≥ 900
Net weight (kg)	≤ 240	≤ 230
Gross weight (kg)	≤ 310	≤ 300

#### 4.1.2 Switch Construction

Each switch is equipped with an internally mounted operating mechanism capable of providing quick-make and quick-break operation in either switching direction. The mechanism is capable of delivering sufficient torque and is provided with latches for each position to assure load interrupting, fault closing and momentary ratings. The mechanism uses compression spring to assure long life and reliability.

The switches have closed-position toggle mechanism to prevent the switch contacts from opening through loss of line voltage. The switches could be operated both manually without power supply by using a NEMA-head hook stick, and electrically by using toggle mechanism and control cabinet. The switches employ a puffer interrupting mechanism.

The enclosures of the switches are made of stainless steel and shall be dust-tight and waterproof. All switch are subject to the gas leakage test at 10<sup>-5</sup> cc/second. Any formation of condensation water is prevented by absorber. The enclosure has a standard protection against corrosion. The finishing coat is light gray.

#### 4.1.3 Standard Feature

1. Manual operation handle, with operating hook(s) having inner diameter of not less than 26 mm, suitable for use with NEMA head hook stick from ground level.
2. Mechanical indicator, FREE/LOCK and ON/OFF.
3. 24 VDC Motor Operator.
4. Connecting terminals for remote "ON" and remote "OFF".
5. Auxiliary contact for ON/OFF switch status.
6. Auxiliary contact for low-pressure gas status.
7. Auxiliary contact for operating mode. (FREE/LOCK)
8. Lifting lug(s).

9. Control cable(s) with plug(s).
10. Ground terminal.
11. Pressure releasing device operating in case pressure builds up higher than permissible design pressure.
12. Safety locking device to prohibit switching in case SF<sub>6</sub> gas pressure drops below permissible minimum pressure, with red indicator easily to be seen from ground level.
13. Mechanical locking lever, having two (2) positions of “Free” and “Lock”.
14. Six (6) porcelain bushings.
15. Six (6) main circuit wires, each 2.5 meter long, with insulated copper conductor.
16. Six (6) bar-tap tee connector for main circuit wires.
17. Nameplate.
18. Hanger assembly made from galvanized steel.
19. Tank coating light gray paint with primer, three millimeters thick.
20. Absorber to absorb moisture and de-composed SF<sub>6</sub> gas.
21. Mechanical operation counter.
22. SF<sub>6</sub> and N<sub>2</sub> filling valve with cover.
23. Mounting kit for cross arm mounting.

The following measuring devices could be incorporated into the switches:

**1. Current sensors (Bushing current transformers)**

The switches have current sensors installed for each phase, able to measure load and fault current through the switches. Outputs of current sensor are 0-1A at rated normal current and supply current input to the feeder remote terminal unit (FRTU) in the future.

**2. Voltage sensors (Voltage transformer)**

The voltage sensors are able to measure line-line voltage at the switch terminal that supply voltage input to the FRTU and control circuit of remote controlled switch. The output of the voltage sensor are 110 VAC phase-phase (0-110VAC) and 110 VAC at the rated normal voltage of the line.

#### **4.1.4 Safety Devices**

##### *(1) Low Pressure Safety Locking Device & Mechanical Indicator*

The switches shall be equipped with a safety-locking device to disable the manual and electrical operation in the event of loss of SF<sub>6</sub> gas below its permissible level. Such lockout status shall be indicated outside of the switches with an indicator. The switches shall be electrically locked from its closing in case the switch is in open status. The operating handle shall be also locked to prevent a possible manual operation in the field while line is still energized.

##### *(2) Overpressure Release Device*

The switches shall be equipped with an overpressure release device that externally mounted on the switches. In the event of an over pressured condition, this over-pressure releasing device shall release the pressure inside of the switches in a controlled manner.

#### **4.2 Controller of remote controlled switch**

The controller consists of any equipment that are suitable for operation and are contained in a control cabinet. The cabinet shall be suitably installed on a prestressed concrete pole at approximately 1.5-3 meters above ground level.

Technical characteristics :

Rated supply voltage : 110 VAC

Rated frequency : 50 Hz

Output voltage : 24 VDC

The controller shall be equipped follow with:

##### **4.2.1 Control cabinet**

The control cabinet are manufactured such that ingress of dust, vermin and small object is prohibited. The control cabinet has been tested the protection class (IP 54) reference with IEC 60529.

The control cabinet has construction with:

- (1) made from sheet steel of not less than 2 mm. in thickness
- (2) have steel channel fixed at the back of the cabinet for mounting on the concrete pole
- (3) include a weather-sealed hole on bottom of the cabinet for routing an antenna cable(approximately 30 mm diameter)

- (4) include free space for mounting the FRTU and radio, minimum contiguous space of 430 mm (height) x 600 mm (width) x 150 mm (depth)
- (5) The labyrinthine slots are provided on the top and bottom of the sides of control cabinet for ventilation
- (6) have 2 holes for ventilation that no way reduce the effectiveness
- (7) be water-tight, dust-tight, and corrosion
- (8) resistant characteristics
- (9) have front hinged door with operating lockable handle
- (10) a thermostat and a heater using to control temperature
- (11) weatherproof fitting for control cables
- (12) provision for handle and padlock.
- (13) ground terminal

#### **4.2.2 Local control panel and control circuit**

The RCS shall be furnished with local swing type control panel for initiating control actions and viewing the status indicators of the switches. Local control panel include the following :

- (1) Switch with fuse and two (2) spare fuses for the control circuit.
- (2) Separate pushbuttons for closing and opening the switch
- (3) Selector switch for LOCAL/REMOTE
  - While switch is in “ Local ” position, control will be permitted only from the local control panel.
  - While switch is in “ Remote ” position, control will be permitted from both the DMS and control panel.
- (4) Indicating lamps for LOCAL and REMOTE.
- (5) Indicating lamps for CLOSE (red) and OPEN (green)
- (6) Indicating lamps for Mechanical FREE/LOCK
- (7) Indicating lamps for low gas pressure.
- (8) Counter to indicate the number of switching cycle of the switches
- (9) Operation circuit on print circuit board (PCB)
- (10) Surge protection equipment separate from PCB



(11) AC/DC converter circuit

(12) DMS interface (control, status and alarm),(if any).

#### **4.2.3 Switch Power Supply (SPS)**

The SPS shall supply 24 VDC to FRTU, 75 watts in transmit mode / 35 watts in receive mode for radio and suitable power for other equipment.

Under normal condition, the SPS are powered from the primary circuit (22kV or 33 kV) via the voltage sensor. In case of AC power failure, the SPS will provide DC power to the switches and associated equipment from a backup power supply system integrated in the SPS.

The backup power supply used battery two 12 VDC enough for operation and communication (customer enquiry), free maintenance, rechargeable battery pack. Battery charger shall be fully recharged when voltage of battery below preset value within 24 hours.

Battery charge shall display status of battery on local control panel following :

- Low battery
- High battery
- Over charger battery
- Ground battery

#### **4.2.4 Distribution Management System (DMS) interface**

The control of the RCS has provisions for opening and closing the switches using output from the FRTU. The control will supply analog and status signals to the FRTU for monitoring the conditions of the primary circuit and the components of the RCS.

The input/output points of the analog and status signals of RCS as below:

<b>Item</b>	<b>Signal</b>	<b>Quantity per switch</b>
<b>Analog signals:</b>		
Current – Phase A	0-1 A	1
Current – Phase B	0-1 A	1
Current – Phase C	0-1 A	1
Voltage A-B	0-110 VAC	1
Voltage B-C	0-110 VAC	1
Voltage C-A	0-110 VAC	1
<b>Status signals:</b>		
Switch Open	Dry contact	1
Switch Close	Dry contact	1
Switch Mechanism Lock	Dry contact	1
Switch Mechanism Free	Dry contact	1
Local Control Mode	Dry contact	1
Remote Control Mode	Dry contact	1
Low Battery Voltage	Dry contact	1
High Battery Voltage	Dry contact	1
Battery Charger over voltage	Dry contact	1
Ground battery	Dry contact	1
SF <sub>6</sub> Gas low pressure	Dry contact	1
Cabinet door open	Dry contact	1
<b>External control signal</b>		
Open switch	Dry contact	1
Close switch	Dry contact	1

#### 4.2.5 Name Plate for Control Cabinet

- Manufacturer's name
- Type
- Serial number
- Year of manufacture
- Rated supply voltage
- Rated supply frequency
- Output voltage
- Total weight

## 5 Remote Controlled Switch Operation

### 5.1 Operating Sequence

#### **Mode: Mechanical FREE**

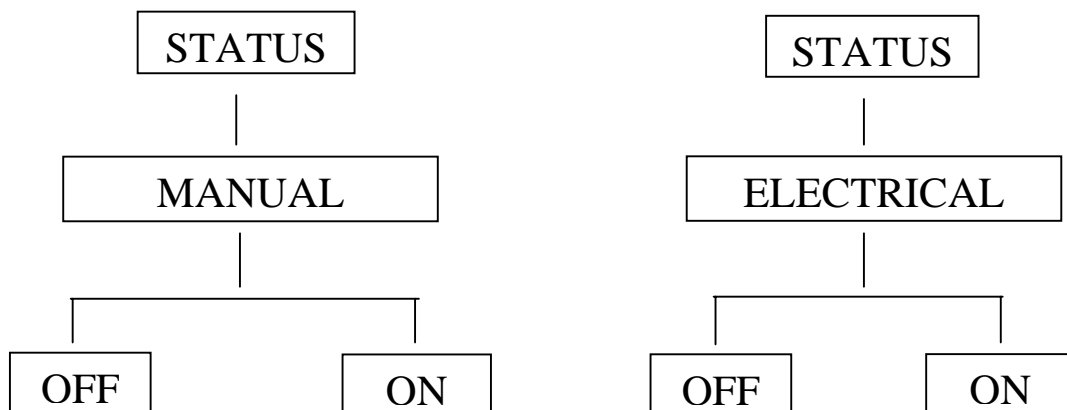

Pull downward the left side of manual operating handle the switch is "OFF"

Pull upward the right side of manual operating handle the switch is "ON"

Push the button "OPEN"

Push the button "CLOSE"

### 5.2 Free / Lock operation

Free / Lock selection mode intended for, when "FREE" position, operation can operated the switches at normal function, but when select "LOCK" position the switches will not change any status and can not be command by anyway. The "FREE/LOCK" lever is installed at the switch tank.

### **5.3 Mechanical operation**

This operation can be operated “ON” or “OFF” switch by hook stick to operate the handle at switch.

### **5.4 Electrical (Local/Remote) Operation**

The switches could be operated either remotely from a master station or locally from a switch controller. To operate either locally or remotely, the operating selection lever must be switched to “FREE” mode. This will allow the switches via a mechanical operation from being operated manually while allowing electrically both local and remote operation.

While in local mode, operation from a master station will be disabled whereas while in remote mode, local operation will be disabled. The switches are equipped with auxiliary output contacts mechanically linked with the switch main contact for reporting the switch positions to master station through associated RTU. The operation is obtained in this instruction manual of local control panel.

## **6 Minimum nameplate Information**

1. Manufacture’s name/country.
2. Type.
3. Manufacturer’s serial number.
4. Year of manufacture.
5. Rated maximum voltage.
6. Rated frequency.
7. Rated normal current.
8. Rated symmetrical interrupting current.
9. Rated short time withstand current, 1-second.
10. Rated short circuit making current.
11. Rated power frequency withstand voltage, 1 min.
12. Rated impulse withstand voltage.
13. Rated auxiliary voltage.
14. Total weight.

## **7 Test**

### ***7.1 Routine***

The switches shall pass the routine tests in accordance with the latest IEC 265-1 and also gas leakage test has to be performed.

### ***7.2 Type Tests***

The switches has been performed type tests in accordance with IEC 265-1 to demonstrate the switches comply with the ratings stated in IEC 694.

In addition to the above, 400 full load operations at 630 amp have been performed at the independent test facilities which verified by CESI.

## **8 Packing**

Each unit of the RCS with installation instruction and its accessories with parts list shall be seaworthy packed in an export crate or wooden case; but each set of accessories with parts list may be separately seaworthy packed in another wooden case to avoid damage during transportation.

**SIDE VIEW**

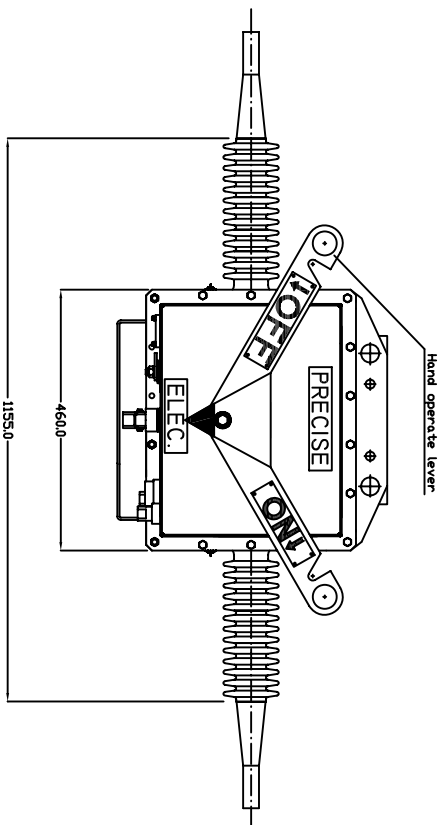
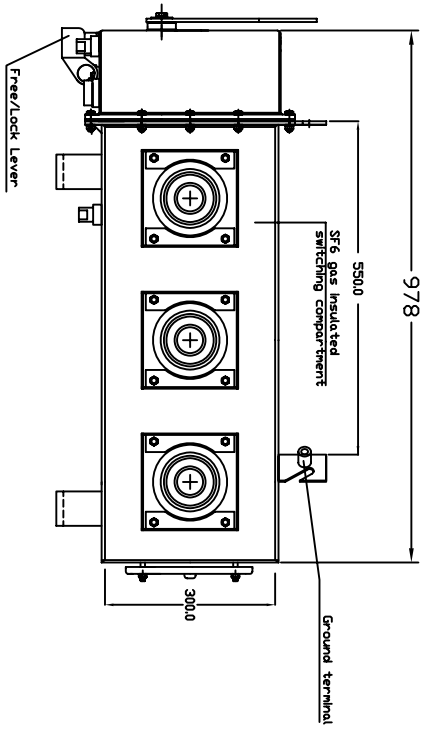

**FRONT VIEW**

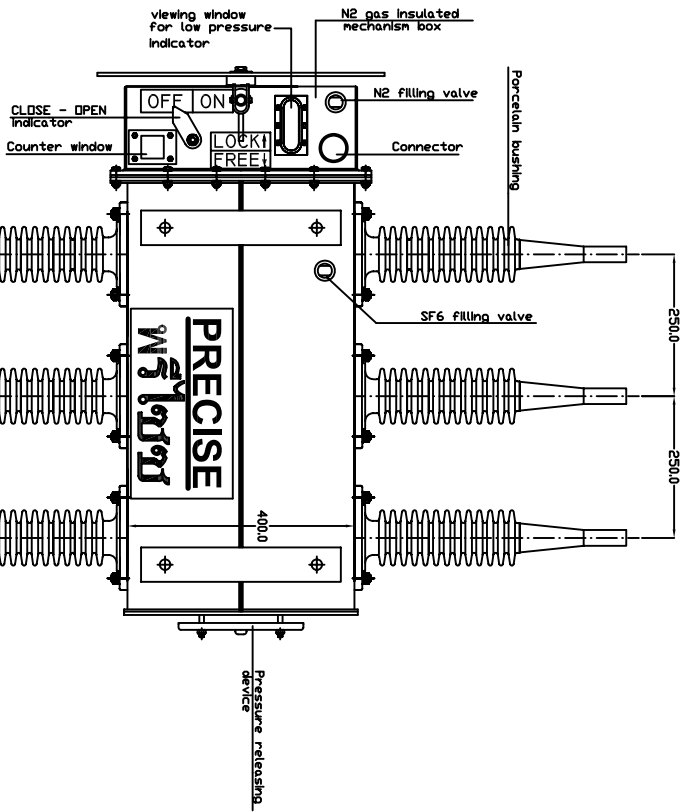

**BOTTOM VIEW**

NOTE : ALL DIMENSIONS ARE IN MILLIMETERS .  
DIMENSIONS IN TOLERANCE ±10%

REMARK	REVISION	DRAWN BY	TITLE
	0	W. PRABHAKARIN	33 kV 400 A SF6 GAS LOAD BREAK SWITCH (TOGGLE OPERATION)
SCALE	NO SCALE	CHECKED BY	DWG NO.
		APPROVED BY	07-G-033-0001
		ISSUED DATE	SH NO.
MATERIAL		PRECISE ELECTRO - MECHANICAL WORKS	1/1

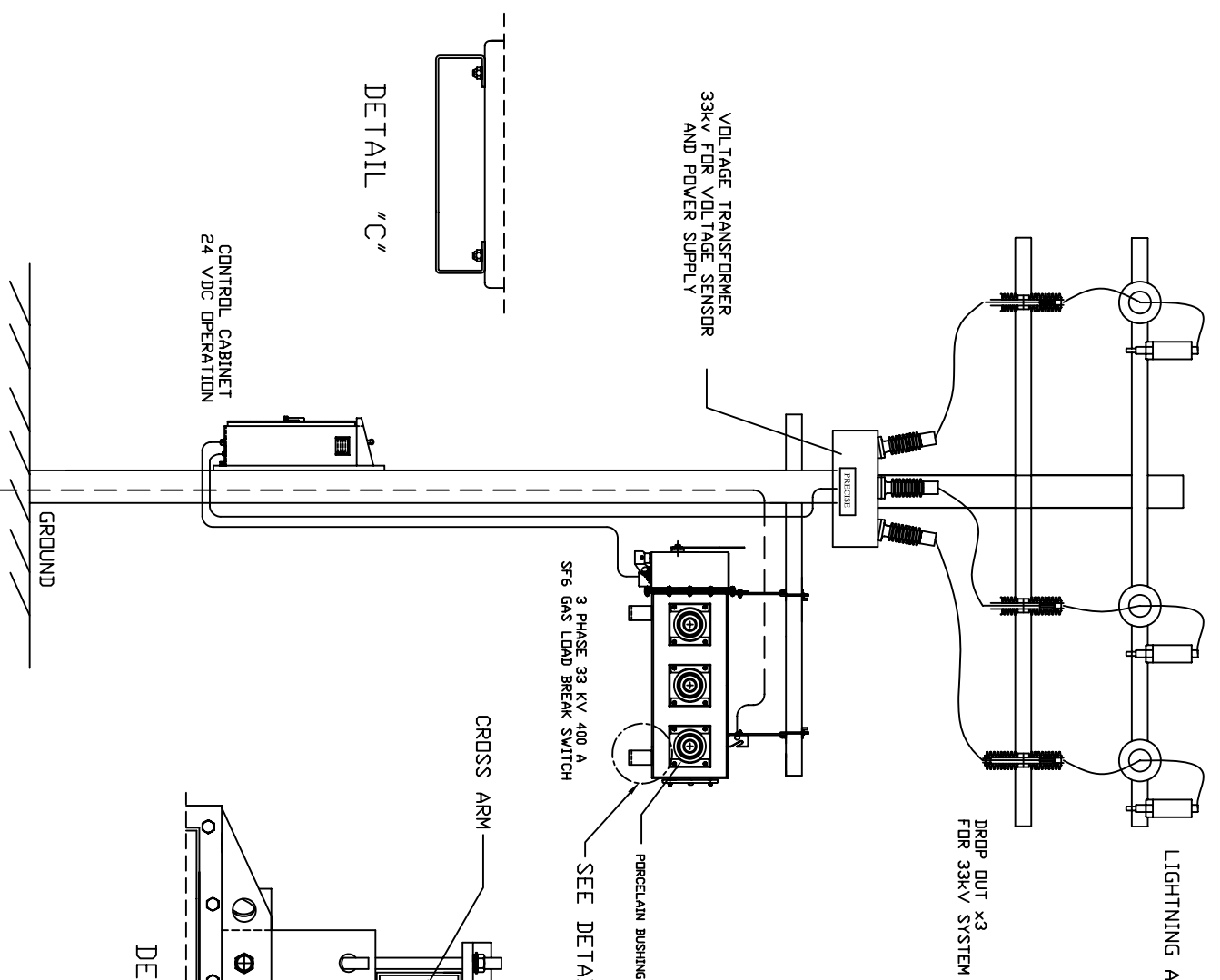

LIGHTNING ARRESTER x6

DRP OUT x3 FOR 33KV SYSTEM

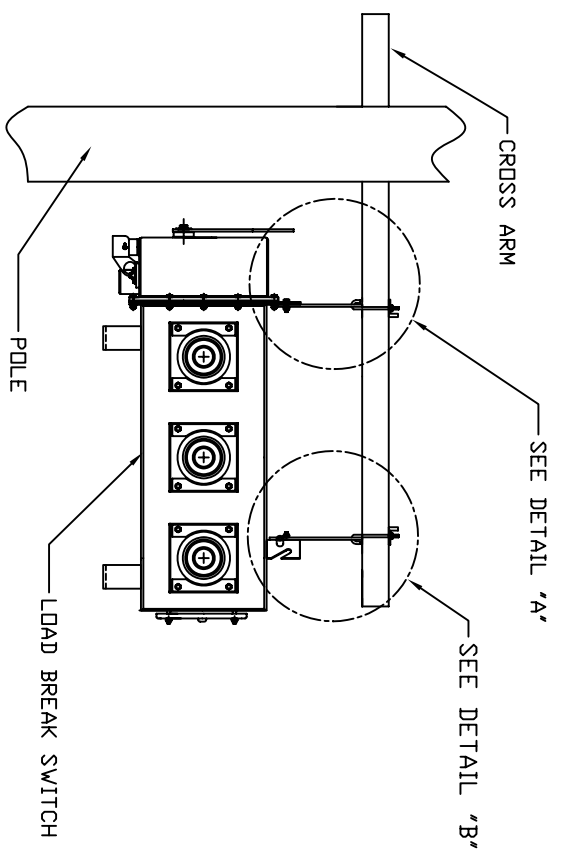

SEE DETAIL 'C'

CROSS ARM

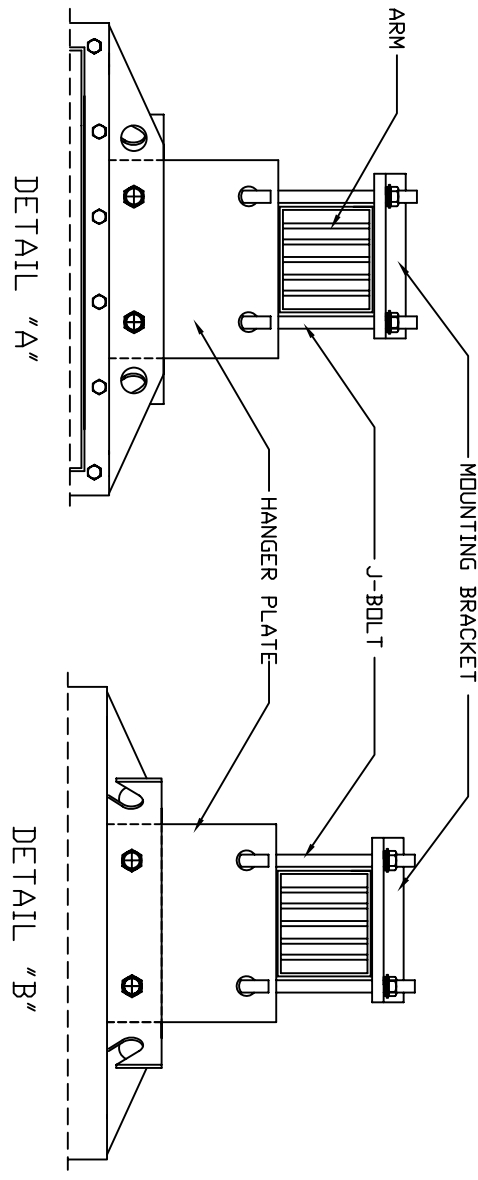

DETAIL 'A'

DETAIL 'B'

DETAIL 'C'

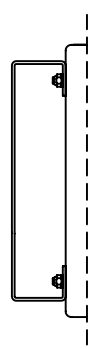

NOTE : ALL DIMENSIONS ARE IN MILLIMETERS .

REMARK	REVISION	DRAWN BY	W. PRABHAKARIN	TITLE
	0	CHECKED BY		POLE MOUNTING DETAILS
		APPROVED BY		FOR
		ISSUED DATE		33KV LOAD BREAK SWITCH
				(TOGGLE OPERATION)
				OPTION 4 Exclude CT
SCALE	NO SCALE	PRECISE ELECTRO -		
MATERIAL		MECHANICAL WORKS		
		DWG NO.	07-G-433-0002	
		SH NO.	1/2	

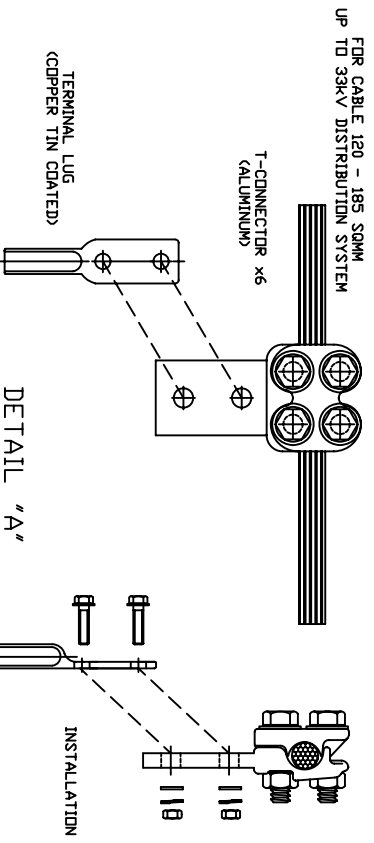
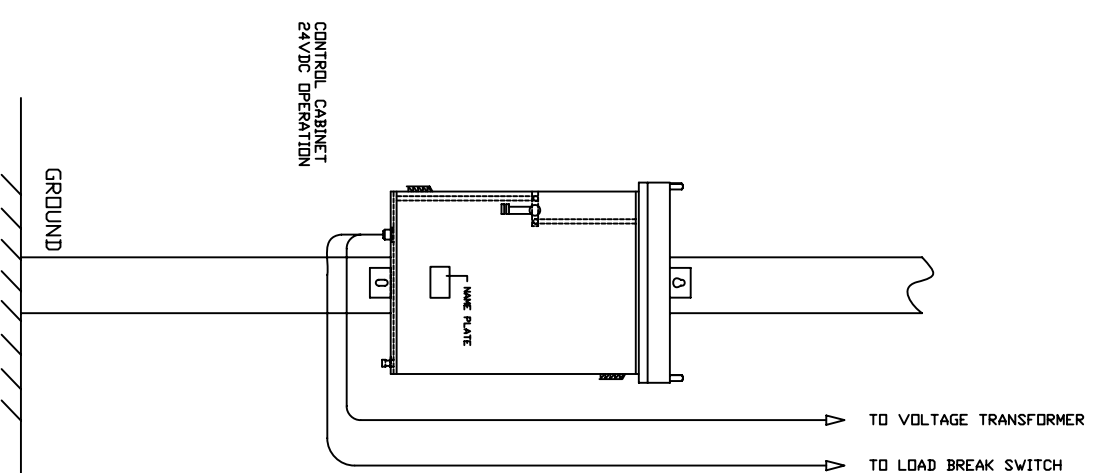
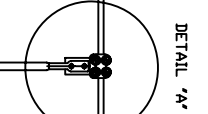
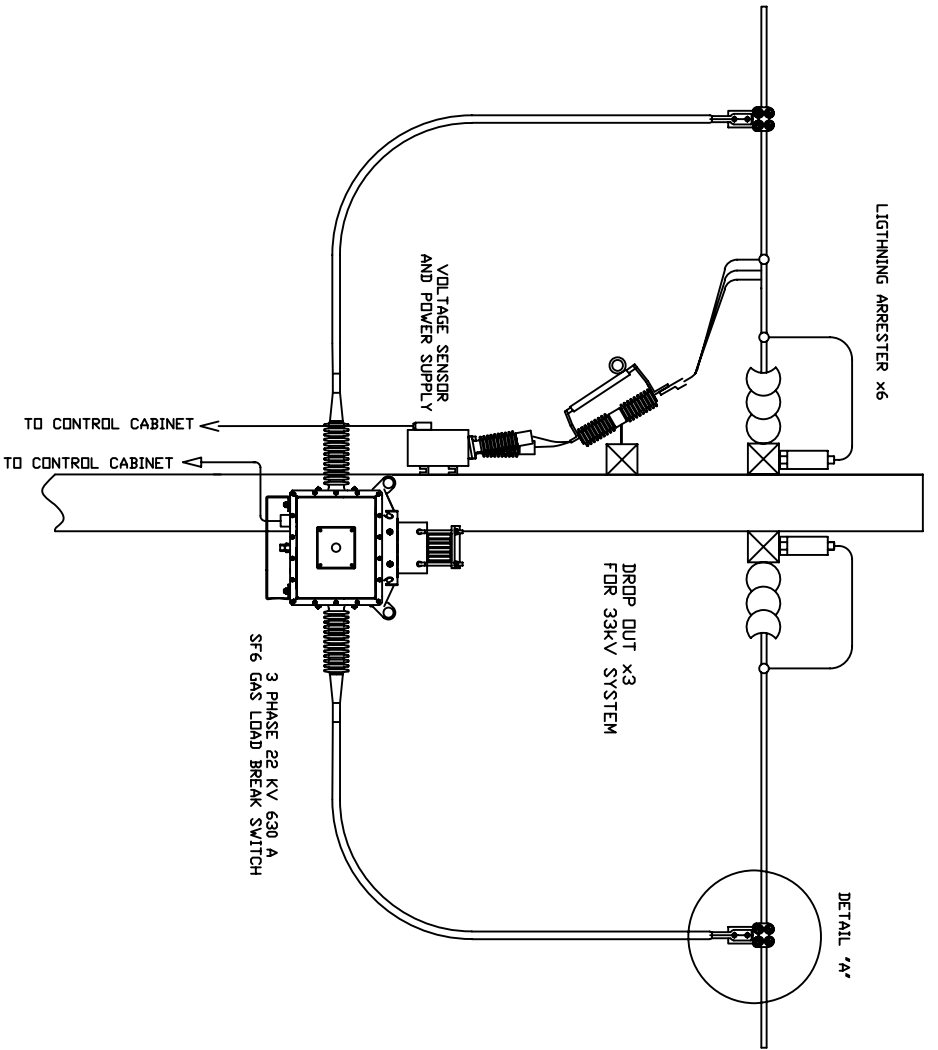

FRONT VIEW

SIDE VIEW



REMARK	REVISION	DRAWN BY	W. PRABHAKARIN	TITLE	POLE MOUNTING DETAILS FOR 33KV LOAD BREAK SWITCH (TOGGLE OPERATION) OPTION 4 Exclude CT
	0	CHECKED BY		DWG NO.	07-G-433-0002
		APPROVED BY		SH NO.	2/2
		ISSUED DATE			
SCALE	NO SCALE	PRECISE ELECTRO - MECHANICAL WORKS			
MATERIAL					

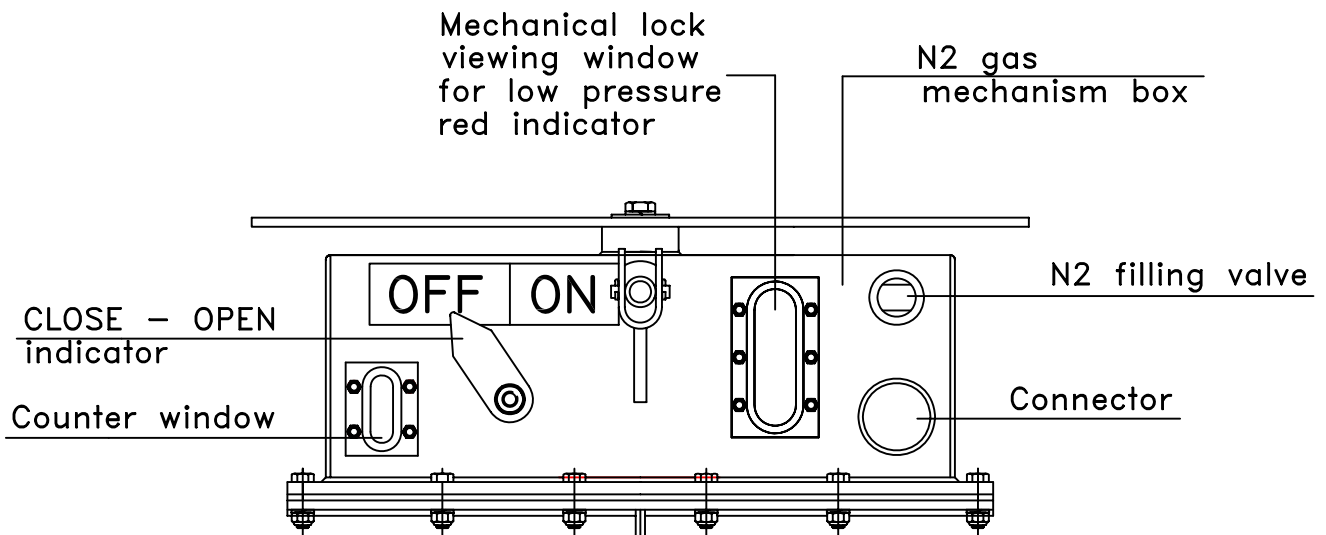
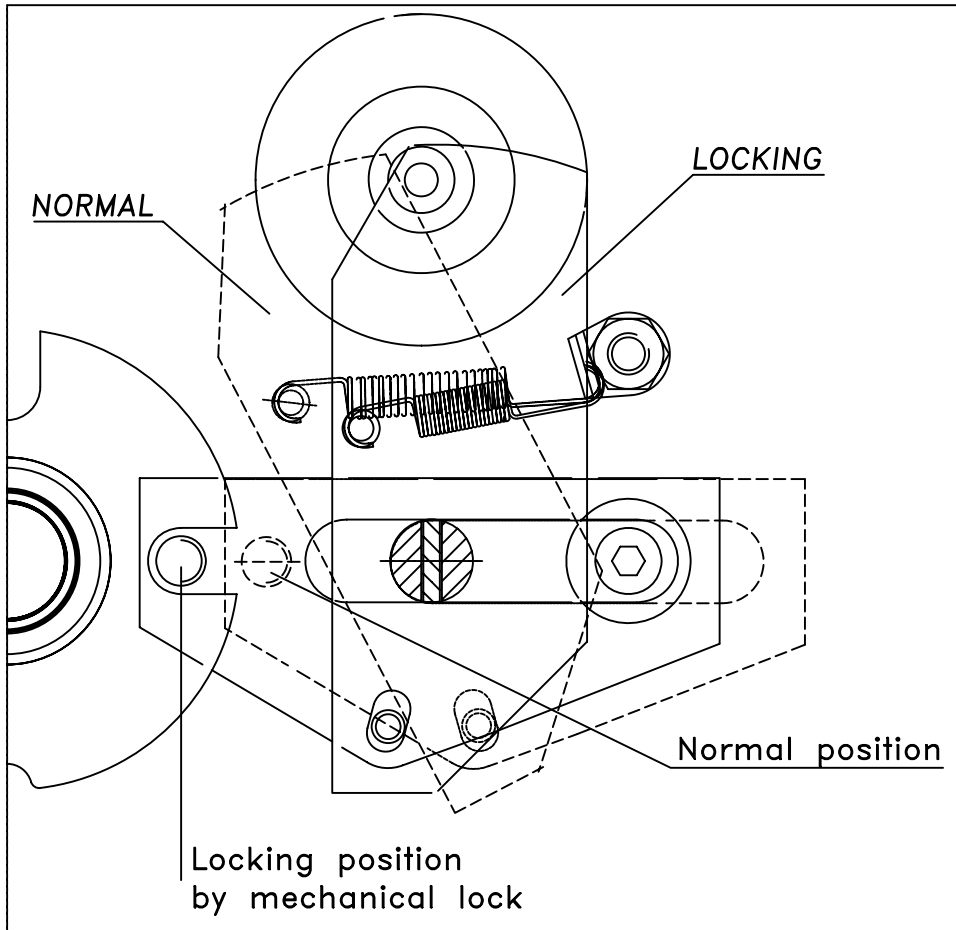

# INSIDE VIEW (MECHANISM)



NOTE : ALL LINEAR DIMENSIONS ARE IN mm.

TOLERANCE UNLESS OTHERWISE SPECIFIED COMPLY WITH DIN 7168 MEDIUM CLASS	REVISION 1	DRAWN BY	W. PRABPAIRIN	TITLE  INTERLOCKING SCHEME LBS (TG) PEA	
	METRIC 	DESIGNED BY			
	SCALE -	APPROVED BY			
SURFACE:	-	ISSUED DATE		DWG NO.	07-M-003-0003
MATERIAL	-	PRECISE ELECTRO - MECHANICAL WORKS 		CODE NO.	07-M-003-0003

170.0

65.0

**PRECISE**

**SF<sub>6</sub> GAS LOAD BREAK SWITCH**

TYPE		ORAP21-396-20MT		SERIAL NUMBER		YEAR	
RATED VOLTAGE		36kV.		RATED INTERRUPTING CURRENT		630 A.	
RATED NORMAL CURRENT		400 A.		RATED SHORT-TIME WITHSTAND CURRENT		12.5 kA.-1 s.	
RATED FREQUENCY		50Hz.		RATED SHORT-CIRCUIT MAKING CURRENT		31.5 kA.	
RATED WITHSTAND VOLTAGE	POWER-FREQUENCY	70 kV.		RATED AUXILIARY VOLTAGE		24Vdc.	
	IMPULSE	170 kV.		IEC 265-1	GROSS/NET WEIGHT.	300/230 Kg.	
MANUFACTURED BY PRECISE ELECTRO-MECHANICAL WORKS./ THAILAND							

BACKGROUND COLOR : WHITEN

BACKGROUND COLOR : BLACK

NOTE : ALL LINEAR DIMENSIONS ARE IN mm.  
: FILL NUMBER OF YEAR'S MANUFACTURING.

TOLERANCE (mm.)	0.5 TO 3	BIGGER THAN 3 TO 6	BIGGER THAN 6 TO 30	BIGGER THAN 30 TO 120	BIGGER THAN 120 TO 400
FINE	±0.05	±0.05	±0.1	±0.15	±0.2
MEDIUM	±0.1	±0.1	±0.2	±0.3	±0.5
COARSE	±0.15	±0.2	±0.5	±0.8	±1.2

APPV'D			UNLESS OTHER WISE SPECIFIED: DIMENSIONS ARE IN MILLIMETERS TOLERANCES: COMPLY WITH DIN 7168 MEDIUM CLASS SURFACE TREATMENT: -	 <b>PRECISE ELECTRO - MECHANICAL WORKS</b>	
Q.A					BELONG TO: Load break Switch (have lead wire ass) / TS-F-00-00-000
VERIF'D				TITLE :	<b>NAME PLATE 33 kV. TG</b>
CHK'D				SCALE: <b>1 : 1</b>	
DRAWN				MATERIAL:	DWG NO. -
	SIGNATURE	DATE	ALMINIUMANODIZE THICKNESS 0.5 MM.	CODE NO. TS-P-00-04-000	REV. NO. 1
1	weight. 260/210 - 300/230	23/ 11 /47	WEIGHT:		
REVISIONS					

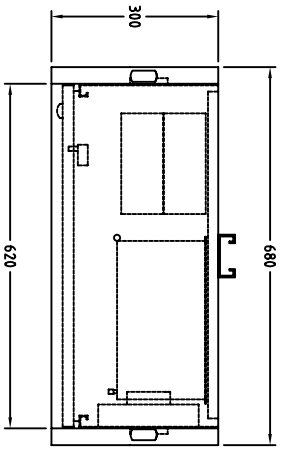

TOP VIEW

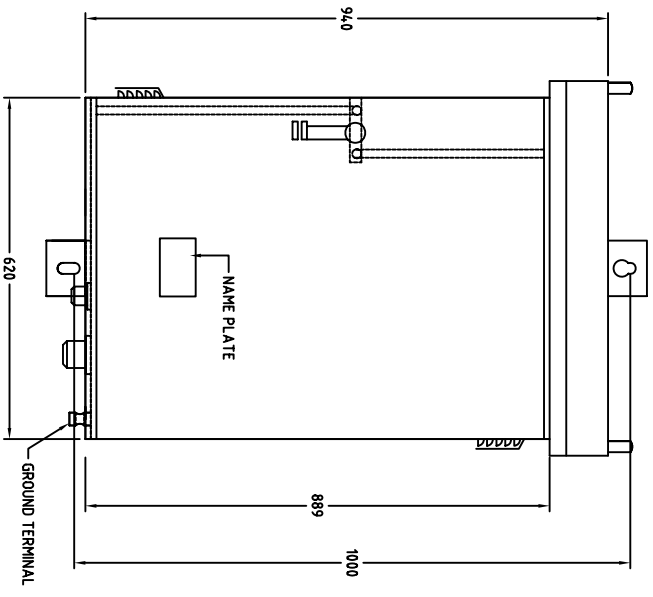

FRONT VIEW

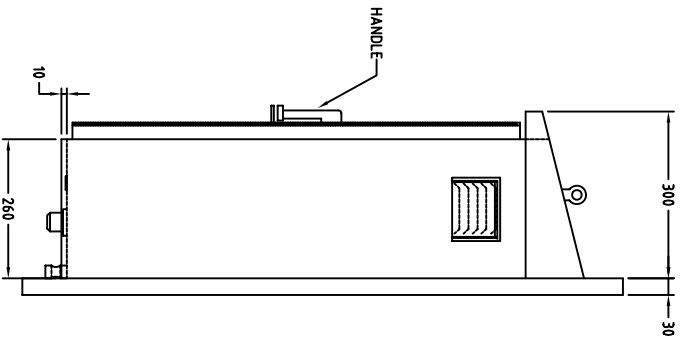

SIDE VIEW

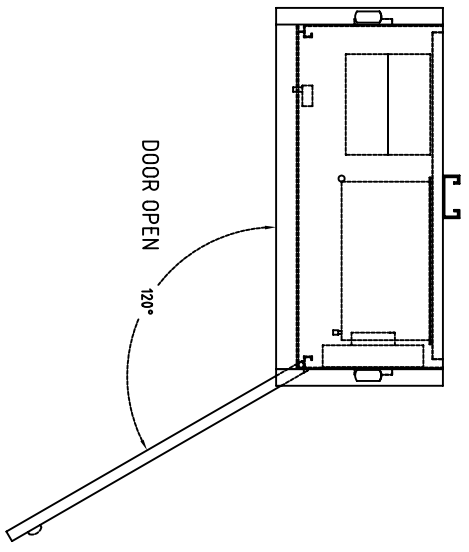

DOOR OPEN 120°

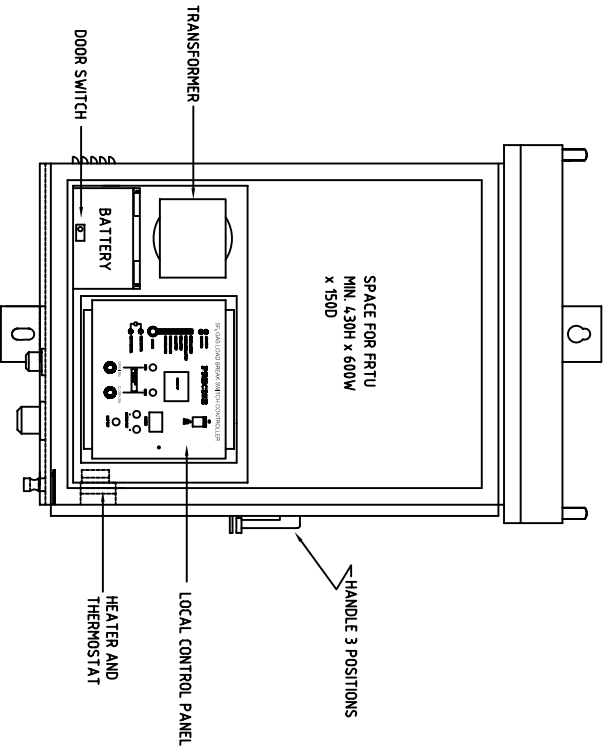

SPACE FOR FRTU  
MIN. 430H x 600W  
x 150D

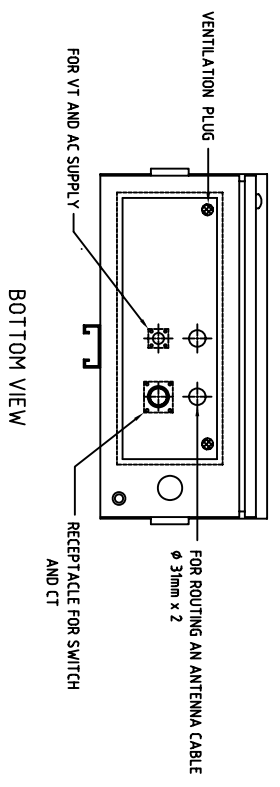

BOTTOM VIEW

Note : All diminsions are in millimeters.

: Steel sheet thk. 2.0 mm

: Dimension in tolerance ± 10%  
: Color RAL 7036

REMARK	REVISION	DRAWN BY	TITLE
	0	KSS	CONTROL BOX
		KSS	
		KIATTISAK S.	
		ISSUED DATE	
SCALE	NOT TRUE SCALE	PRECISE ELECTRO -	DWG NO. 07G-001-0001
MATERIAL		MECHANICAL WORKS	SH NO. 1/1

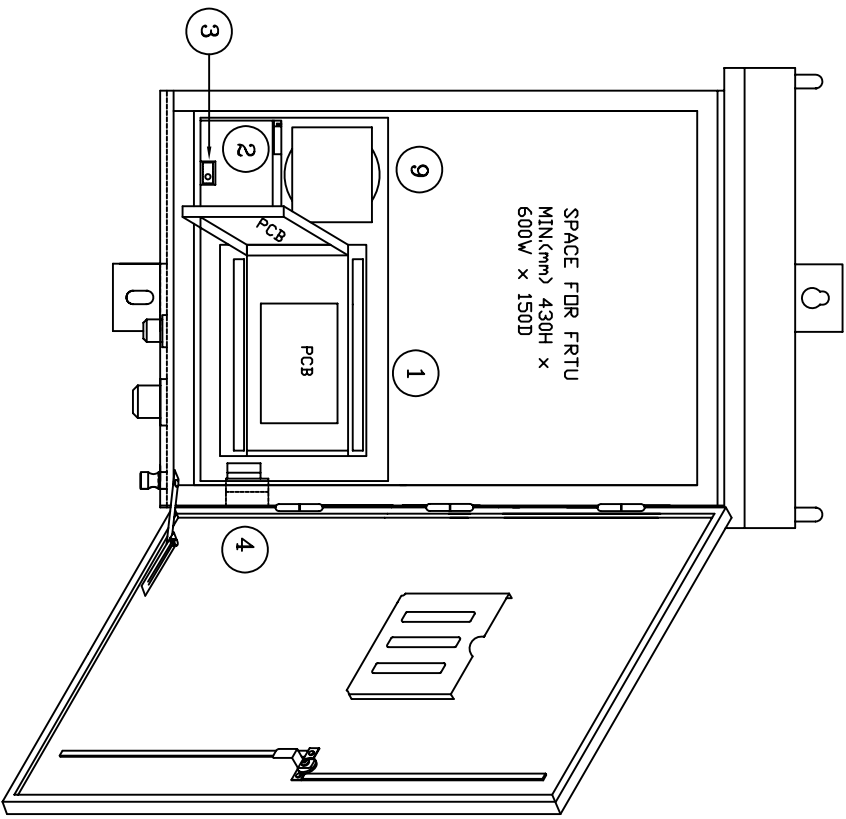
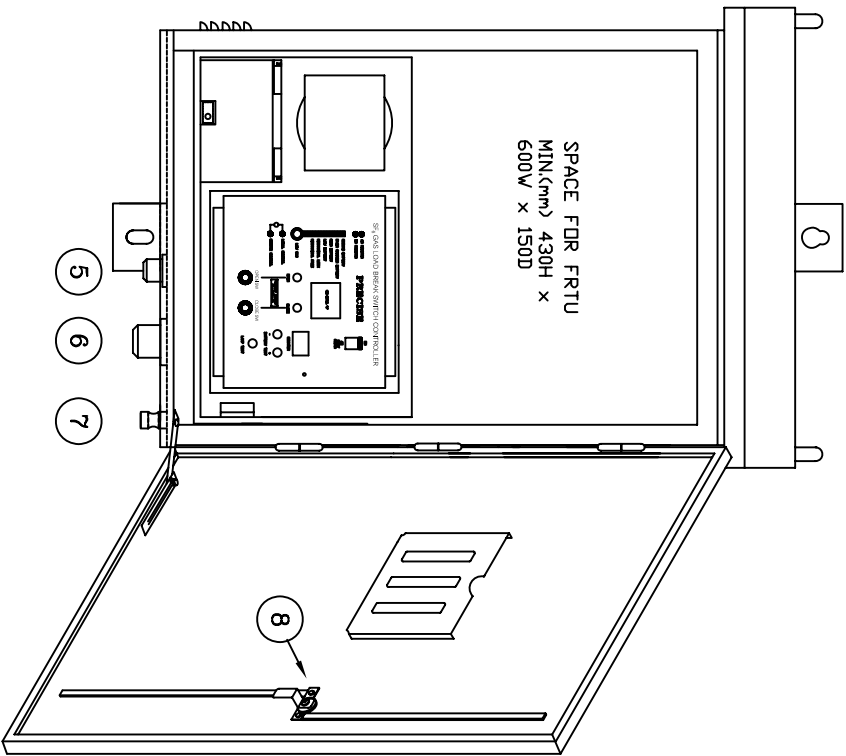

NO.	DESCRIPTIONS	QUANTITY
1	CONTROLLER FOR SWITCH	1
2	BATTERY 12V	2
3	DOOR SWITCH	1
4	HEATER AND THERMOSTAT	1
5	CONNECTOR FOR PT	1
6	CONNECTOR FOR SWITCH AND CT	1
7	GROUND TERMINAL	1
8	HANDLE 3 POSITION	1
9	TRANSFORMER	1

LOCATION OF EQUIPMENTS  
INSIDE PANEL :

PCB=PRINT CIRCUIT BOARD  
TR=TRANSFORMER  
TH=THERMOSTAT

REMARK	REVISION	DRAWN BY	KSS	TITLE
	0	DESIGNED BY		LOCATION OF EQUIPMENT FOR CONTROL BOX
		APPROVED BY		
		ISSUED DATE		
SCALE	NO SCALE	PRECISE ELECTRO - MECHANICAL WORKS		DWG NO. 07G-000-0005
				REF NO.

# SF<sub>6</sub> GAS LOAD BREAK SWITCH CONTROLLER

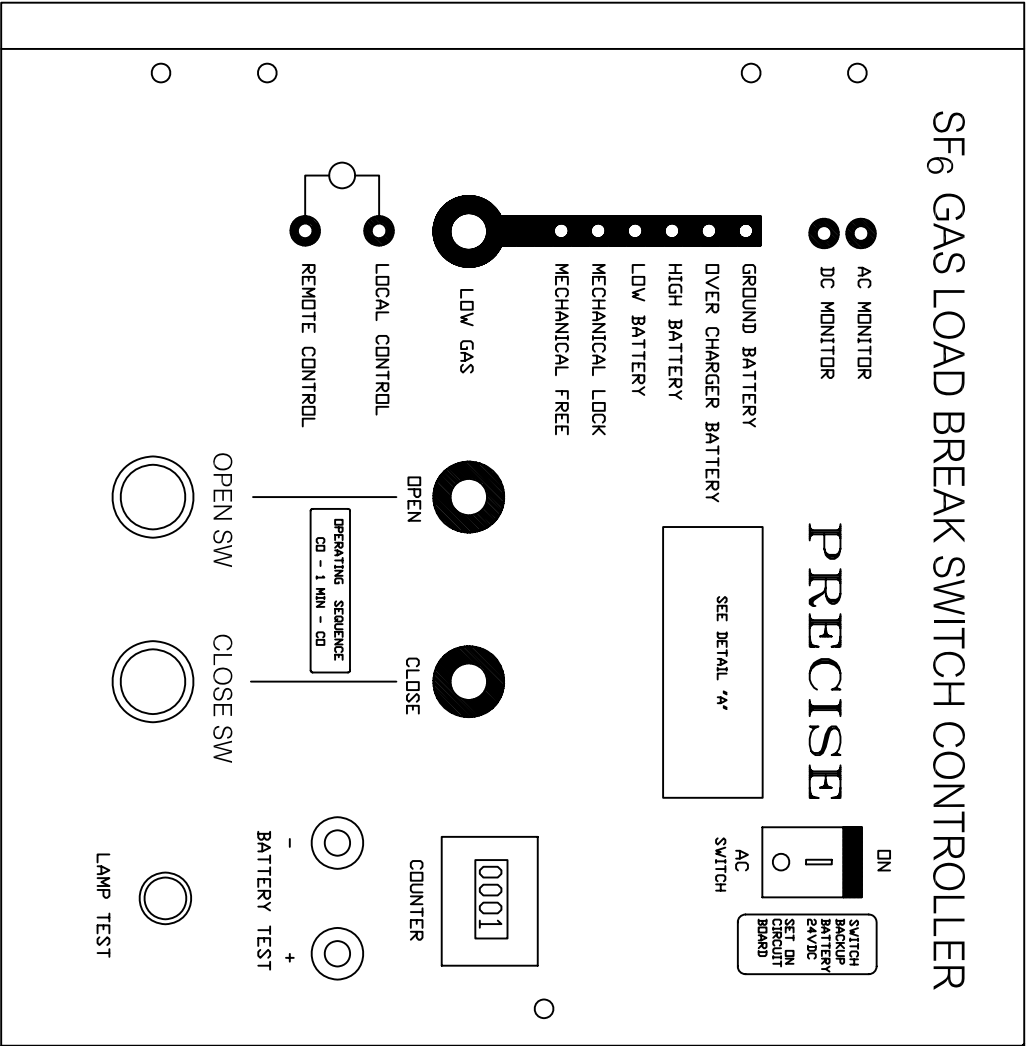

DETAIL "A"

**CAUTION**

IN CASE OF MAINTENANCE,  
MUST TURN OFF AC POWER SUPPLY SWITCH  
AND BATTERY SWITCH,  
THEN LOCK DOOR FOR SAFETY.

⚠

ขอความร่วมมือ  
ในการดำเนินการบำรุงรักษา ต้องปิดตัวตัด  
AC POWER SUPPLY และตัวตัด BATTERY  
แต่ยังไม่ตัดกุญแจก่อนไปตัดด้วย

REMARK	REVISION	DRAWN BY	KIATTSAK S.	TITLE
	0	CHECKED BY		LABEL OF FRONT PANEL
		APPROVED BY		
		ISSUED DATE		
SCALE		PRECISE ELECTRO - MECHANICAL WORKS		DWG NO. 07G-001-0007
MATERIAL	A1 2.0 mm.			REF. NO.

PRECISE CONTROL BOX  
FOR  
SF6 GAS LOAD BREAK SWITCH

○	TYPE: SERIAL NO.: YEAR: RATED SUPPLY VOLTAGE : AC 110V RATED FREQUENCY : 50 Hz OUTPUT VOLTAGE : DC 24V WEIGHT:                      Kgs CONTRACT NO.:	○
---	--	---

REMARK	REVISION	DRAWN BY	KSS	TITLE NAME PLATE OF CONTROL CABINET FOR LBS TOGGLE MECHANISM	
	0	DESIGNED BY	KSS		
		APPROVED BY	KIATTISAK S.		
		ISSUED DATE	APRIL 26, 2004		
SCALE	NO SCALE	<b>PRECISE ELECTRO - MECHANICAL WORKS</b>		DWG NO.	08G-001-0005
MATERIAL	Al 0.25 mm thk.			REF NO.	