

MATERIAL HANDLING

FIND IT FAST

Totes and Tote Dollies	188-197
ToteAll 2000® Molded Poly Boxes	189
Mega-Totes and Bulk Tubs and Dollies	198-199
ChillTotes™ and Freezer Baskets	200-201
Platters and Platter Dollies	202-205
Steamer Pans	204
Food Boxes, Dough Boxes and Dollies	206-207
Ingredient Bins	208-209
Utility Carts	210-211
Platform and Hand Trucks	212-215
Tilt Trucks	216-217
Combo Bins	218
Tubs, Vats and Storage Bins	220-222
Combo Caps, Liners and Bands	223
Freezer Spacers, Slipsheets and Pallets	224-226
Shelving and Storage Cabinets	227-229
Wheels and Casters	230-233
Stainless Steel Buggies, Trucks and Pails	234-236
Dunnage Racks	237
Work Tables and Table Tops	238-241
Cutting Boards	241
Mixing Paddles, Spatulas, Forks and Shovels	242-247
Food Containers, Scoops and Scrapers	248-253
Buckets, Lids, Pails and Jugs	254-255
Drums, Trash Cans, Liners and Accessories	256-262
Receiving Desk	263



ToteAll 2000® Poly Box Lids



Poly Tote Liners

Clean-ups have never been easier! Liners are approved for food contact.

- Liners eliminate the need for cleaning totes — just pull off the used liner and throw away!
- Blue, 1.5 mil polyethylene liners fit all ToteAll 2000® totes.



CALL to request a FREE SAMPLE!

ITEM NO.	PRODUCT	EACH
3195 73211	Lid, White	\$10.25
3195 59001	Lid, Gray	10.25

ITEM NO.	PRODUCT	DIMENSIONS	CASE
E179 2215	Blue Tote Liners	22" x 15" x 20"	\$149.95

▶ 500 PER CASE.

Economy Blemished Tote

- Resists cuts and scratches. • Cross stack and nestable.
- Easy to handle grips. • NOT food approved.
- Color: multi-colored. • Some may have imprinting.
- ToteAll 2000® lids (shown above) will fit these non-food totes.
- Dimensions: 13 inches x 22 inches x 8-1/2 inches ID; 15-1/2 inches x 25 inches x 8-3/4 inches OD.



NOTE: Lids sold separately.

ITEM NO.	PRODUCT	EACH
3195 57761	Economy Blemished Tote	\$9.15

ToteAll 2000® Imprinted Poly Boxes



- Our same famous poly boxes imprinted with "Edible" or "Inedible" verbiage.
- Dimensions: 13 inches x 22 inches x 8-1/2 inches ID; 15-1/2 inches x 25 inches x 8-3/4 inches OD.

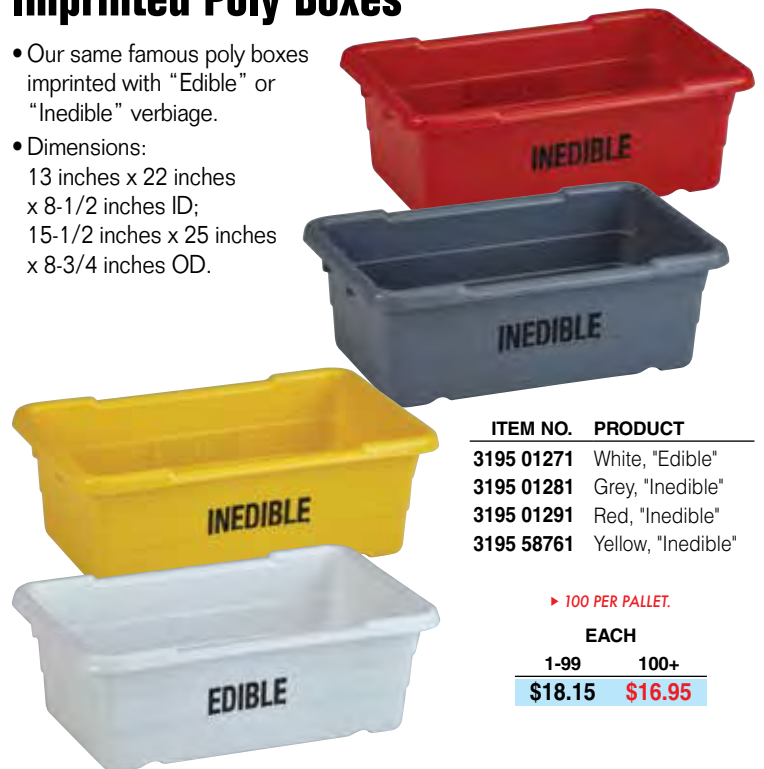

ITEM NO.	PRODUCT
3195 01271	White, "Edible"
3195 01281	Grey, "Inedible"
3195 01291	Red, "Inedible"
3195 58761	Yellow, "Inedible"

▶ 100 PER PALLET.

EACH	
1-99	100+
\$18.15	\$16.95

▶ SEE PAGE 206

FOR ADDITIONAL FOOD BOXES AND DOLLY





ToteAll 2000[®]

Molded Poly Boxes

• Max temp: 410 °F/210 °C.

TOTAL 2000[®]



50 Pound Capacity
Weighs only 3.8 pounds empty
1.3 cubic feet



90° cross stacking via stacking grooves built into bottom of tote.



Smooth interior and wide radius corners for easy cleaning.

Stacking grooves allows cross stacking.



Molded-in handles.

Reinforced nesting-stops prevent jamming.

Wall thickness: 1/8"

Finely etched exterior resists cuts and scratches.



All Colors Are FOOD APPROVED!

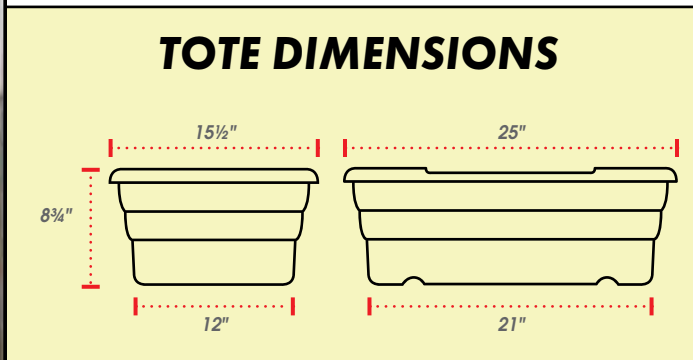

4:1 nesting ratio saves space.

ITEM NO.	COLOR
3195 06641	Orange
3195 2013	Tan
3195 46331	Yellow
3195 46351	Green
3195 46341	Blue
3195 00021	Purple
3195 46321	Red
3195 73041	Pink
3195 07071	White
3195 06621	Gray
3195 46361	Black

▶ 100 PER PALLET.

EACH

1-99 100+

\$13.75 \$12.05

Our ToteAll 2000[®] poly boxes are a first-class product with ribs along the bottom lifting ledge to increase the strength of the ledge when it's used in tote dollies. These reinforcements make our first-class tote a level above our competitors.

PRICES ARE SUBJECT TO CHANGE • MINIMUMS MAY APPLY • VISIT OUR WEBSITE FOR CURRENT PRICING.

Comfort Curve™ Color-Coded Tote Boxes

- Comfort Curve™ handles for a sure, comfortable grip.
- Reinforced rims reduce bending, bowing and breaking.
- Contour lid design allows easy box-on-box stacking.
- Available in different colors for HACCP zone use.
- NSF Std 2 – meets the criteria for food contact and cleanability.
- Molded polyethylene construction withstands temperatures from 32 °F to 180 °F.
- Tote dimensions: 20 inches x 15 inches x 5 inches.
- Lid dimensions: 20 inches x 15 inches x 1 inch.



Totes

ITEM NO.	COLOR
6387 13621	Yellow
6387 13581	Blue
6387 13641	Black
6387 13661	Gray
6387 13631	White

▶ 12 PER CASE.

EACH

1-11	12+
\$14.95	\$13.95

Lids

ITEM NO.	COLOR
6387 13781	Yellow
6387 13691	Blue
6387 13731	Black
6387 13741	Gray
6387 13751	White

▶ 12 PER CASE.

EACH

1-11	12+
\$12.25	\$10.25

Molded Poly Totes

- Made of molded polyethylene.
- Resist cuts and scratches.
- Food usage USDA 3-A and NSF 2 certified.
- Easy to handle grips.
- Colors: white or gray.
- Capacity: 4-5/8 gallons.
- Dimensions: 15 inches x 20 inches OD.
- Depth: 5 inches.
- Nestable.



▶ 10 PER PALLET.

EACH

ITEM NO.	COLOR
1770 07291	White
1770 79501	Gray

1-9	10+
\$12.95	\$11.95

Aluminum Bus Cart

Push design for various mobile tasks such as serving, bussing and general utility.

- Three shelf units have three edge lips up and one lip down to help hold products on shelves.
- Frame constructed of 1-inch x 1-inch x 0.070-inch wall tubing.
- Shelves are aluminum sheet, 16-1/2 inches x 24 inches x 0.080 inch thick.
- Included four 5-inch stem-type swivel casters.
- Dimensions: 27-3/4 inches L x 16-1/2 inches W x 39 inches H.

NOTE: Totes sold separately.



EACH

ITEM NO.	PRODUCT	EACH
3775 0026	Aluminum Bus Cart	\$414.65

PRICES ARE SUBJECT TO CHANGE • MINIMUMS MAY APPLY • VISIT OUR WEBSITE FOR CURRENT PRICING.

11-Quart Food Box Mini Tote

Rounded corners for easy cleaning.

- Made of durable, commercial grade plastic, reinforced bottom and ribs for added strength.
- Nestable containers stack securely for efficient use of space.
- Food-approved. • Commercial dishwasher safe.
- Color: white.



NOTE: Lid sold separately.

► 6 PER CASE.

ITEM NO.	PRODUCT	DIMENSIONS	EACH	
			1-5	6+
1770 36901	Tote Box, White	14-3/8" x 12-3/8" x 5-3/8"	\$19.95	\$18.95
1770 80181	Lid, White	15" x 12-3/4"	16.95	15.95

Aluminum Tote

- Constructed of seamless aluminum alloy with an anodized finish.
- Sturdy and lightweight.
- Nest when not in use.
- Weight: 5 pounds.
- Capacity: 1.9 cubic feet; 75 pounds.



ITEM NO.	PRODUCT	DIMENSIONS	EACH
1695 90371	Tote	26" x 15-1/2" x 8"	\$88.95
1695 0072	Lid	26" x 16" x 1"	49.95

Distribution Totes

The only tote accepted by many retail food operations.

- Complies with sanitation and material handling requirements of many retail food processors.
- Sturdy design with reinforcing ribs and deep molded hand grips for convenient lifting and carrying.
- For use in refrigerated trailers, freezers and walk-in storage coolers.
- Withstand temperatures from -20 °F to 120 °F.
- Made of injection-molded polyethylene.
- Stack with optional covers, nest when empty.
- Cross-stack and interlock on a 40 inch x 48 inch pallet.
- FDA compliant.
- Color: beige.



ITEM NO.	PRODUCT	DIMENSIONS	WEIGHT	CAPACITY	EACH
1814 41681	Tote, Standard Size	24" x 16" x 8.7"	3-3/4 lb	40 lb	\$14.95
1814 07681	Tote, Large Size	24" x 16" x 10-3/4"	5 lb	55-60 lb	15.95
1814 07701	Lid, Standard Size	24" x 16" x 1-1/2"	2-1/5 lb		9.95
1814 9014	Lid, Large Size	24-3/10" x 16-3/10" x 1-4/5"	4 lb		10.20

Aluminum Tote Dolly

For use in moving and storing chicken boxes.

- One side of dolly is open for easy placement and removal of chicken boxes.
- Corners are open for easy cleaning.
- Equipped with four, 3-inch swivel casters.
- Strong and durable aluminum will not rust.
- Shipping weight: 12 pounds.



ITEM NO.	PRODUCT	DIMENSIONS	EACH
3775 6223	Aluminum Tote Dolly	23" x 16" x 6"	\$114.35

Jumbo Poly Totes

- Injection molded will handle large quantities of product.
- Rugged, high-density polyethylene.
- Stainless steel bails form base for stacking.
- Capacity: 100 pounds.
- Color: gray.
- Weight: 9 pounds.



ITEM NO.	PRODUCT	DIMENSIONS	EACH
1695 0655	Tote w/o Bails	16-9/10" x 34-1/2" x 9-9/10"	\$100.95
1695 0653	Tote w/Bails	16-9/10" x 34-1/2" x 9-9/10"	94.95



Tote with Hinged Lids

- Containers stack when closed or nest when open to provide efficient use of space.
- Pebble-grain bottom surface provides excellent conveyor traction.
- Heavily reinforced hinge elements reduce breaking and cracking.
- Cover recessed within the perimeter of container to protect against cover breakage while conveyed or shipped.
- Molded-in security tie holes.



Security holes are compatible with a variety of tote closures, from ties to padlocks.



Gray

ITEM NO.	OUTSIDE BASE DIMENSIONS	OUTSIDE TOP DIMENSIONS	HEIGHT	EACH
1814 11431	19-1/10" x 13-3/10"	21-9/10" x 15-1/5"	9"	\$18.95
1814 11821	18-3/5" x 12-9/10"	21-9/10" x 15-1/5"	12-9/10"	21.95
1814 12441	24-2/5" x 14-7/10"	26-9/10" x 12-9/10"	12-1/10"	28.95
1814 14021	25-4/5" x 188"	27-9/10" x 20-9/10"	15-1/5"	54.95

Blue

ITEM NO.	OUTSIDE BASE DIMENSIONS	OUTSIDE TOP DIMENSIONS	HEIGHT	EACH
1814 11441	19-1/10" x 13-3/10"	21-9/10" x 15-1/5"	9"	\$18.95
1814 11831	18-3/5" x 12-9/10"	21-4/5" x 15-1/5"	12-9/10"	20.30
1814 12431	24-2/5" x 14-7/10"	26-9/10" x 12-9/10"	12-1/10"	28.95
1814 14031	25-4/5" x 188"	27-9/10" x 20-9/10"	15-1/5"	54.95

Transport Storage Tubs

Approved for direct food contact.

- Meets all USDA specifications and can be used for meat, seafood, poultry, fishing, confectionery, bakery and grain applications.
- Manufactured from high-density polyethylene.
- Can be used for transporting, freezing and storing.
- Snap tight lid keeps contents secure during transport.
- Tubs can be used as stand-alone items or with low steel undercarriages.
- Capacity: 500 pounds, 8-Bushel.
- Tub Dimensions: 46-8/10 inches L x 26-1/2 inches W x 16-9/10 inches H.



NOTE: Can be used with undercarriage, sold separately.

A. Tub

ITEM NO.	COLOR	EACH
5281 0283	White	\$361.95
5281 0285	Green	
5281 0258	Blue	
5281 0284	Red	
5281 0282	Yellow	

B. Lid

ITEM NO.	COLOR	EACH
5281 02781	White	\$187.95
5281 02811	Green	
5281 02801	Blue	
5281 02791	Red	
5281 02771	Yellow	

ITEM NO.	PRODUCT	EACH
5281 6913	Steel Undercarriage	\$561.95

Super-Duty Brute® Totes with Lids

Approved for direct food contact.

- NSF Standard #2 commercial grade material withstands heavy-duty use.
- Ergonomic grip handles provide greater mobility.
- Handles have drain holes to reduce the risk of bacteria build up.
- Snap-tight lid keeps contents secure during transport.
- Reinforced rib constructed bottom allows product to be dragged.
- Stacks for efficient use of space.



14 gallon capacity: 400 pounds.
20 gallon capacity: 500 pounds.

ITEM NO.	PRODUCT	DIMENSIONS	EACH	
			1-5	6+
1770 30001	14 Gallon, Gray	27-9/10" x 17-2/5" x 10-7/10"	\$44.95	\$43.95
1770 30011	14 Gallon, White	27-9/10" x 17-2/5" x 10-7/10"	44.95	43.95
1770 31001	20 Gallon, Gray	27-9/10" x 17-2/5" x 15-1/10"	49.95	48.95
1770 31011	20 Gallon, White	27-9/10" x 17-2/5" x 15-1/10"	49.95	48.95

Palletote™ Shipping Containers

180° stack/nest shipping boxes.

- Durable, reusable boxes are ideal for shipping and many in-process material handling jobs.
- Made with USDA 3A (dairy) Sanitary Standards and Meat and Poultry Equipment Group Listed.
- Materials are FDA-compliant for food contact and certified to NSF 2 Standards.
- Injection-molded polyethylene construction for uniform wall thickness.
- Nest boxes when not in use, or stack full boxes with lids.
- Recommended operating temp: -10 °F to 130 °F.
- Smooth poly interior is easy to clean.
- Color: gray.

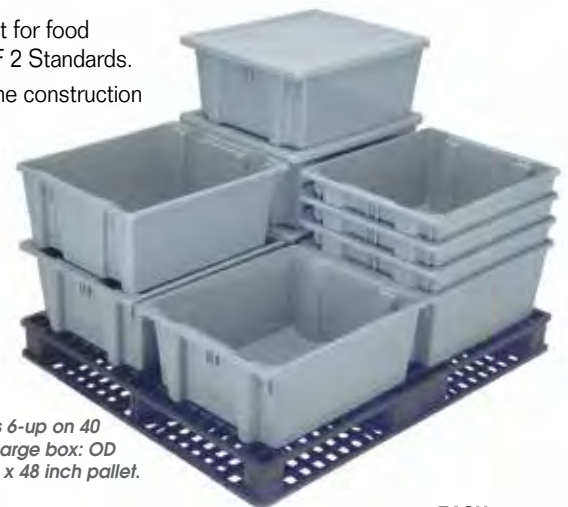

Standard box: OD fits 6-up on 40 inch x 48 inch pallet. Large box: OD fits 4-up on 40 inch x 48 inch pallet.

ITEM NO.	PRODUCT	DIMENSIONS	EACH	
			1-9	10+
1770 73241	Standard Box	19-1/2" x 15-1/2" x 10"	\$49.95	\$48.95
1770 47061	Standard Lid		25.95	24.95
1770 73301	Large Box	23-1/2" x 19-1/2" x 10"	74.95	73.95
1770 73281	Large Lid		28.95	27.95



Heavy-Duty Welded Aluminum Merchandising/Picking Cart

Display your promotional merchandise on this mobile cart or use it as a mobile picking cart.

- Designed to hold up to nine totes at an 18° angle for an eye-catching display.
- Construction:
Framework: 1-1/2 inch x 1-3/4 inch wall tubing.
Shelves: 1-1/4 inch x 2-1/4 inch wall T-Bar.
Lug stops: 1 inch x 1 inch x 0.094 inch wall tubing.
- All-welded aluminum construction, will never rust.
- 5-inch platform casters, 2 swivel and 2 rigid.
- Shelf size: 50 inches L x 20-5/16 inches W.
- Overall size: 53 inches L x 22 inches W x 65-1/2 inches H.

▶ SEE PAGE 189
Totes Sold Separately

ToteAll 2000®



ITEM NO.	PRODUCT	CASTERS	CAPACITY	EACH
3775 1230	Merchandising/Picking Cart	.2C and 2D	1,000 lb	\$965.95

Heavy-Duty Welded Aluminum 18+ Tote Dolly

- Each dolly has the capacity to hold up to 50 pounds of product per tote.
- Made of heavy-duty 1-1/4 inch x 1-1/2 inch D-shaped tube hoop frame.
- All welded aluminum dollies hold 16 inch W x 25 inch L x 8-1/2 inch H totes.
- All dolly seams are welded and sealed.
- Four: 5-inch platform casters, 2 swivel and 2 rigid.
- Overall Size: 54-1/8 inches L x 26-1/2 inches W x 72-5/8 inches H.

▶ SEE PAGE 189
Totes Sold Separately

▶ SEE PAGES 231-233
Replacement Caster Options



D-shaped aluminum tube.



NOTE: Not recommended with full totes on top row.



ITEM NO.	PRODUCT	CASTERS	CAPACITY	EACH
3775 0025	Aluminum 18+ Tote Dolly	.2C and 2D	1,000 lb	\$1,022.65

Heavy-Duty Welded Aluminum 24+ Tote Dolly

- All welded aluminum dollies hold 16 inch W x 25 inch L x 8-1/2 inch H totes.
- Each dolly has the capacity to hold up to 50 pounds of product per tote.
- Made of heavy-duty 1-1/4-inch x 1-1/2-inch D-shaped tube hoop frame.
- All dolly seams are welded and sealed.
- Four: 5-inch platform casters, 2 swivel and 2 rigid.
- Overall Size: 50 inches L x 36-1/2 inches W x 72-5/8 inches H.

▶ SEE PAGE 189
Totes Sold Separately

▶ SEE PAGES 231-233
Replacement Caster Options



D-shaped aluminum tube.



NOTE: Not recommended with full totes on top row.

ITEM NO.	PRODUCT	CASTERS	CAPACITY	EACH
3775 0034	Aluminum 24+ Tote Dolly	.2C and 2D	1,000 lb	\$1,520.35

Standard-Duty Welded Aluminum Tote Dollies

ToteAll 2000®



- Standard dollies are made of 1 inch square tube frame with 1 inch square tube cross supports.
- All welded aluminum dollies accept 16 inch x 25 inch x 8-1/2 inch high totes.
- Equipped with four swivel stem casters with 5 inch black polyolefin wheels, 2 with brakes.
- All dolly seams are welded and sealed.
- Each dolly has the capacity to hold up to 50 pounds of product per tote.



All sizes are made of square tube frames and supports.

▶ SEE PAGE 189
Totes Sold Separately



ITEM NO.	PRODUCT	CASTERS	DIMENSIONS	EACH
3775 6265	A. Single Tote Dolly	2A and 2B	16" x 26" x 19"	\$121.45
3775 0511	B. Double-Stacked Tote Dolly	2A and 2B	15-3/4" x 28-1/4" x 33"	176.85
3775 9316	C. Side-by-Side Double Tote Dolly	2A and 2B	32-1/2" x 26" x 19"	182.65
3775 6262	D. Four Tote Dolly	2A and 2B	18.9" x 26" x 51"	239.35
3775 6264	E. Six Tote Dolly	2A and 2B	18.9" x 26" x 71"	307.65



Standard-Duty 5" Replacement Stem Casters

Capacity: 135 pounds per wheel.

- Fits all Standard-Duty Dollies shown on this page.
- 7/16-inch stem. • Width: 1 inch. • Black polyolefin wheels.
- Standard-Duty Dollies require 2A and 2B casters.

▶ SEE PAGES 231-233
For More Caster Options

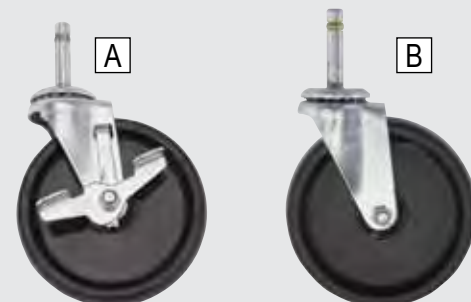

ITEM NO.	PRODUCT	EACH
0844 4202	A. Swivel, w/Brake	\$15.95
0844 4201	B. Swivel, w/o Brake	13.95

Heavy-Duty Welded Aluminum Tote Dollies

- Single, double and triple tote dollies are made of heavy-duty 1-1/4-inch square tube hoop frame.
- All dolly seams are welded and sealed.
- All welded aluminum dollies hold 16 inch W x 25 inch L x 8-1/2 inch H totes.
- Each dolly has the capacity to hold up to 50 pounds of product per tote.
- Six, seven and ten tote dollies are made of heavy-duty 1-1/4 inch x 1-1/2 inch D-shaped tube hoop frame.



ITEM NO.	PRODUCT	CASTERS	DIMENSIONS	EACH
3775 9317	A. Single Tote Dolly	2A and 2B	16-1/4" x 26" x 19"	\$202.65
3775 9318	B. Double-Stacked Tote Dolly	2A and 2B	16-1/4" x 28-1/4" x 33"	224.65
3775 9319	C. Side-by-Side Double Tote Dolly	2A and 2B	33" x 26" x 19"	234.15
3775 9304	D. Three Tote Dolly	2A and 2B	16" x 29" x 42-1/2"	311.85
3775 3797	E. Side-by-Side Six Tote Dolly	2C and 2D	29-3/4" x 20-3/4" x 38"	397.85
3775 2535	F. Six+ Tote Dolly	2C and 2D	18-3/4" x 26-1/2" x 72"	395.95
3775 4198	G. Side-by-Side Ten Tote Dolly	2C and 2D	29-1/2" x 31-1/2" x 61"	444.15



HEAVY-DUTY DOLLY TUBING INFO

ALL HEAVY DUTY DOLLIES USE 1" SQUARE TUBE CROSS-SUPPORTS

	Square Tubing 1-1/4" x 1-1/4" x 0.10"	A, B, C and D have square tubing frame.
	D-Shaped Tubing 1-1/4" x 1-1/2" x 0.08"	E, F and G have D-shaped tubing frame.

Heavy-Duty 5-Inch Replacement Casters

Capacity: 250 pounds per wheel.

- Fits all Heavy-Duty Welded Dollies shown on this page.
- Single, double and triple tote dollies are equipped with four, 5-inch swivel stem casters, 2 with brakes.
- Six, seven and ten tote dollies are equipped with four, 5-inch plate casters, 2 swivel and 2 rigid.
- Sealed wheel bearings with guard cap.
- Shielded double ball bearing raceway swivel.
- Width: 1-3/8 inches.



ITEM NO.	PRODUCT	EACH
0844 22191	A. 5" Caster, Stem Swivel, No Brake	\$16.95
0844 22201	B. 5" Caster, Stem Swivel, With Brake	19.95
0844 22181	C. 5" Caster, Plate Rigid	15.95
0844 22171	D. 5" Caster, Plate Swivel, With Brake	24.95

PRICES ARE SUBJECT TO CHANGE • MINIMUMS MAY APPLY • VISIT OUR WEBSITE FOR CURRENT PRICING.

Aluminum Knock-Down Tote Dollies

Save on freight, knock-down dollies ship UPS!

- 1-inch square aluminum tubing. • Easy assembly with Allen wrench provided.
- 5-inch swivel casters, 2 with brakes.
- Weight capacity: 50 pounds per tote.

ToteAll 2000®

MADE IN USA

KNOCKS DOWN FOR SHIPPING



Assembles or knocks down easily with the (Allen wrench supplied.)



A

▶ SEE PAGE 189
Totes Sold Separately



B



C

▶ SEE PAGES 231-233
For More Caster Options

ITEM NO.	PRODUCT	DIMENSIONS	EACH
2990 4255	A. Double Tote Dolly	16" x 28" x 33-1/4"	\$383.24
2990 4256	B. Four Tote Dolly	16" x 28" x 52-1/2"	544.37
2990 6424	C. Six Tote Dolly	29-3/4" x 20-3/4" x 38"	578.38

Stainless Steel Knock-Down Tote Dollies

- 1-inch square tubular stainless steel.
- Equipped with 4 swivel casters, 2 with brakes.

MADE IN USA

KNOCKS DOWN FOR SHIPPING



Quick and easy assembly using eight standard 1/4-inch bolts (supplied).

▶ SEE PAGE 189
Totes Sold Separately

▶ SEE PAGES 231-233
For More Caster Options



A

B

C



ITEM NO.	PRODUCT	DIMENSIONS	EACH
2990 2936	A. Double Tote Dolly	18-2/5" x 25-1/2" x 30"	\$545.53
2990 2937	B. Four Tote Dolly	18-2/5" x 25-1/2" x 50"	670.30
2990 2938	C. Six Tote Dolly	18-2/5" x 25-1/2" x 70"	809.78

Heavy-Duty Aluminum 6+ Tote Knock-Down Dolly

- Constructed of 1-1/4-inch square aluminum tubing.
- Knocks-down for convenient UPS shipping.
- 5-inch x 1-3/8-inch heavy-duty, swivel stem casters, 2 with brakes.
- Replacement casters available.
- Easy assembly.
- Shipping weight: 34 pounds.
- Capacity: 300 pounds or 6, 50-pound totes.



Top row tote storage



ITEM NO.	PRODUCT	DIMENSIONS	EACH
3775 6263	Six Tote, Vertical Dolly	19" x 26" x 71"	\$329.65
0844 22191	Replacement Swivel Caster		\$16.95
0844 22201	Replacement Swivel Caster w/Brake		19.95

Aluminum Empty Tote Dolly

- Transfer up to 25 empty totes.
- Able to cross stack totes.
- Equipped with 4 swivel casters for greater mobility.

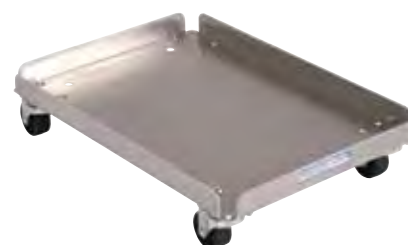

▶ SEE PAGE 189
Totes Sold Separately

ITEM NO.	PRODUCT	DIMENSIONS	EACH
3775 7326	Empty Tote Dolly	26" x 17" x 6"	\$128.05
3775 04101	Replacement Casters		\$36.75

Aluminum Knock Down Table with Poly Top

- Made with heavy-duty aluminum frame.
- Includes four non-locking 4-inch casters.
- Includes 1 gray, 50-pound capacity poly tote.
- Available with or without 6-inch backslash.

NOTE:

50 pound capacity tote INCLUDED!

▶ SEE PAGE 189

Additional Tote Colors Available



Optional Backslash.



Tote slides easily on built-in slide rails.



ITEM NO.	PRODUCT	DIMENSIONS	F.O.B. FACTORY EACH
2510 3501	Poly Top Table w/Tote	30" x 24" x 34"	\$458.95
2510 3502	Poly Top Table w/Tote and 6" Backslash		607.95

▶ SEE PAGE 233
Locking Casters Available

Mega-Totes and Dollies



- FDA-compliant, removable polyethylene totes hold up to 66 gallons (9 bushels). • Color: natural.
- Heavy-duty, 250 pound capacity, 5-inch x 1-3/8-inch swivel stem casters roll smoothly over varying surfaces.
- 4-bushel tote: 30 gallon capacity; 6-bushel tote: 41 gallon capacity; 8-bushel tote: 57 gallon capacity; 9-bushel tote: 66 gallon capacity.
- All-welded aluminum dolly will not rust. • Optional shoebox type lids available. • Height: 36 inches without lid, 36-1/2 inches with lid.



Scan this QR code with your mobile device to view a video of the features of this Mega Tote.



ITEM NO.	PRODUCT	TOP DIMENSIONS	BOTTOM DIMENSIONS	SHIPPING WT.	EACH
4743 2204	A. 4-Bushel Mega-Tote	21-1/4" x 32-3/4" x 15-3/4"	24-3/4" x 15"	12 lb.	\$189.95
4743 2214	4-Bushel Mega-Tote Lid	22-1/2" x 34"		5 lb.	114.95
3775 1104	4-Bushel Mega-Tote Dolly	20-1/2" x 30-1/4" x 30-1/2"		13 lb.	266.25
4743 2206	B. 6-Bushel Mega-Tote	23-1/4" x 32-1/4" x 20"	23-1/2" x 16"	13 lb.	199.95
4743 2216	6-Bushel Mega-Tote Lid	24-1/2" x 33-1/2"		6 lb.	119.95
3775 0019	6-Bushel Mega-Tote Dolly	23" x 28" x 26"		22 lb.	265.65
4743 2108	C. 8-Bushel Mega-Tote	24-1/4" x 36-1/4" x 23"	28-1/2" x 17"	23 lb.	209.95
4743 2218	8-Bushel Mega-Tote Lid	25" x 37-1/2"		9 lb.	149.95
3775 0018	8-Bushel Mega-Tote Dolly	24" x 34" x 23"		18 lb.	271.95
4743 2009	D. 9-Bushel Mega-Tote	29-1/2" x 41-1/2" x 19"	33" x 21"	25 lb.	259.95
4743 2219	9-Bushel Mega-Tote Lid	30" x 43"		12 lb.	159.95
3775 1019	9-Bushel Mega-Tote Dolly	27" x 37-1/2" x 27"		24 lb.	294.95
0844 22191	Replacement 5" Swivel Stem Casters (250 lb Capacity)				16.95

PRICES ARE SUBJECT TO CHANGE • MINIMUMS MAY APPLY • VISIT OUR WEBSITE FOR CURRENT PRICING.

Bulk Tubs and Dollies

Food approved tubs are ideal for processing areas.

- 14-bushel tub: 105 gallon capacity; 16-bushel tub: 120 gallon capacity; 18-bushel tub: 135 gallon capacity; 20-bushel tub: 150 gallon capacity.
- All aluminum base will never rust. • FDA compliant tubs are white.



Seamless molded polyethylene interior with rounded corners, resists cuts/scratches.



Aluminum dolly features heavy-duty polyolefin/polyurethane plate casters — 2 rigid and 4 swivel allowing for zero degree turning. Rated for 1,500 pounds.



ITEM NO.	PRODUCT	TOP DIMENSIONS	BOTTOM DIMENSIONS	SHIPPING WT.	EACH
4743 2014	A. 14-Bushel Tub	43-3/4" x 31-3/4" x 28-1/2"	.35-1/2" x 15"	28 lb.	\$369.95
3775 0005	14-Bushel Dolly	27-3/4" x 39-1/2" x 9"		30 lb.	383.15
4743 2016	B. 16-Bushel Tub	45" x 31" x 29-1/2"	.36" x 23"	31 lb.	419.95
3775 0006	16-Bushel Dolly	26-3/4" x 40-1/4" x 9"		30 lb.	461.95
4743 2018	C. 18-Bushel Tub	46-1/4" x 34" x 31"	.38" x 25-1/2"	41 lb.	499.95
3775 0007	18-Bushel Dolly	30-1/4" x 42-3/4" x 9"		31 lb.	439.85
4743 1020	D. 20-Bushel Tub	46" x 34" x 32-1/2"	.37" x 25"	48 lb.	549.95
3775 0008	20-Bushel Dolly	29-1/4" x 40-3/4" x 9"		33 lb.	465.05



WHY CALL FOR PRICING?

At the time of this printing, supply chain sourcing on certain items was dynamic due to a COVID-19 outbreak – with product availability and costs fluctuating from week to week. Because of this, you will see certain products displayed without a price in this Buyers Guide and instead are listed as *Call for Pricing*. On such items, please call our Customer Service team at 800-456-5624 or visit our website at www.bunzlpd.com where pricing is always up-to-date. ■

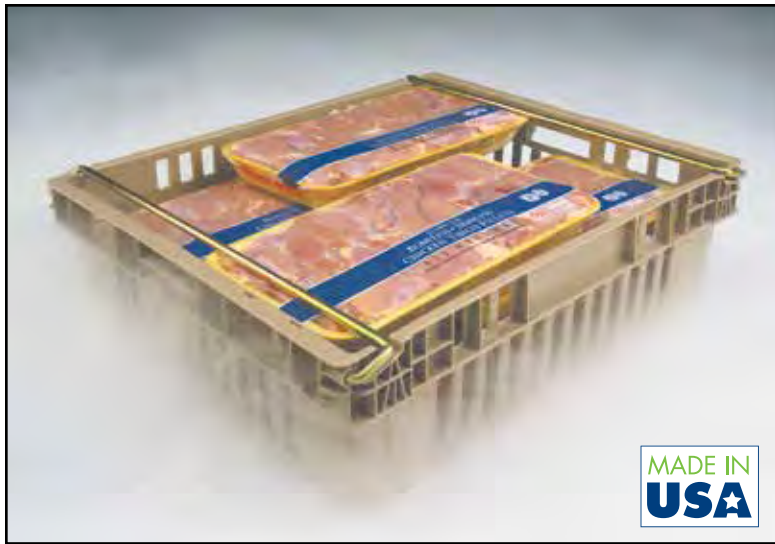

Cuts Conventional Freezing Time IN HALF!



ChillTote™ Trays

- ChillTotes™ fit four-up on standard 42-inch x 48-inch pallets.
- Light-weight freezer proof, stackable/nestable and easy to clean.
- Flow-thru basket design allows maximum air circulation for faster, more efficient freezing.
- Heavy ribs on bottoms of trays prevent the contents of upper and lower trays from freezing together.
- Injection molded from high-density polyethylene to withstand constant freezer temperatures without cracking or warping.
- Capacity: 1.4 cubic feet, 50 pounds.



Two 3/8 inch zinc-plated steel wire bails swing down to allow nesting and swing up for stacking.

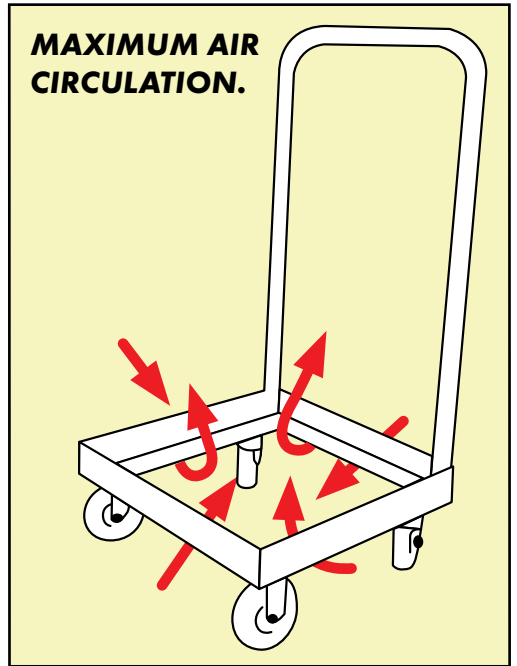

NOTE: Maximize your freezer space and eliminate basket shelving by using ChillTote™ aluminum transport dollies. SEE BELOW.

ITEM NO.	PRODUCT	DIMENSIONS	CAPACITY	EACH
1814 28631	Standard Chilltote™	22" x 19" x 6"	50 lb.	\$21.95
1814 58901	Deep Chilltote™	24" x 20" x 13"	75 lb.	33.95

Heavy-Duty ChillTote™ Dollies

- Heavy-duty aluminum dollies make a portable chill system.
- Two swivel and two rigid casters with durable 5-inch heavy-duty wheels. Uses 2F and 2G casters.
- Load capacity: 750 pounds.

NOTE: Handle and ChillTote™ trays sold separately.

ITEM NO.	PRODUCT	DIMENSIONS	SHIPPING WT.	EACH
3775 2860	A. Single	22-1/4" x 22-1/2" x 8-1/2"	14 lb.	\$210.95
3775 2861	B. Double	22-1/4" x 42-1/2" x 8-1/2"	20 lb.	224.65
3775 4527	C. Triple	22-1/2" x 63" x 8-1/2"	22 lb.	290.85
3775 2862	Optional 35" Handle			47.25



► SEE PAGE 233 For Replacement Casters

ChillTote™ Dollies

- For use in moving and storing ChillTotes™.
- Open corners for easy cleaning • Will not rust.
- Strong, durable aluminum construction with four 3-inch swivel casters.



NOTE: ChillTote™ trays sold separately. SEE ABOVE.



ITEM NO.	PRODUCT	DIMENSIONS	SHIPPING WT.	EACH
3775 9322	Dolly	23-1/2" x 19" x 6"	15 lb.	\$114.35

PRICES ARE SUBJECT TO CHANGE • MINIMUMS MAY APPLY • VISIT OUR WEBSITE FOR CURRENT PRICING.

Freezer Totes

Heavy-duty poly food boxes won't warp, split or crack when frozen.

- Molded bottom ridges. • Pebble finish exterior.
- Wide radius corners and a smooth finish for easy cleaning.
- Optional standard tote reinforced lid for stacking.
- Temperature range: -60 °F (blast freeze) to 170 °F.
- Color: white.

A. Standard Freezer Totes

OD: 21-1/4 inches L x 15-3/4 inches W

ITEM NO.	PRODUCT	EACH
6604 47761	5" Deep	\$10.95
6604 47771	7" Deep	11.95
6604 47781	Lid	7.95

B. Large Freezer Totes

OD: 25 inches L x 16 inches W x 8-1/2 inches H

ITEM NO.	PRODUCT	EACH
3502 58951	8-1/2" Deep	\$28.95



Our FREEZER TOTE SPREADER is ideal for stacking and palletizing freezer totes.

ITEM# 3502 53441
CALL FOR DETAILS

Universal Freezer Basket Dollies

- Dollies accept freezer baskets shown above at right (sold separately).
- Welded aluminum construction with no crevices to trap bacteria.
- Two plate swivel and two plate rigid 5-inch casters with heavy-duty wheels.
- Replacement casters available. Uses 2F and 2G casters.



Easy slide angles have built-in stops to prevent freezer baskets from sliding all the way out.



All-Purpose Freezer Baskets

Heavy, chrome-plated, welded steel wire construction.

- Designed to fit our standard basket dollies.
- Ideal for freezing or cooling product.
- Nest when empty to save space.
- Dimensions: 28 inches L x 17 inches W.

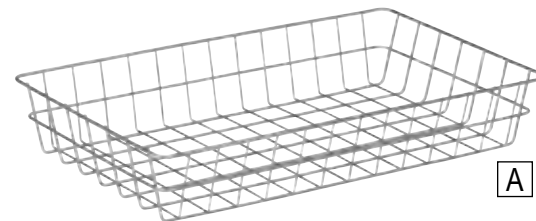

Baskets are available in two depths; 5 inch or 7 inch.



▶ 7 PER CASE.

ITEM NO.	PRODUCT	EACH	
		1-6	7+
3056 0722	A. 5" Deep	\$28.95	\$27.95
3056 4326	B. 7" Deep	42.95	41.95

ITEM NO.	PRODUCT	DIMENSIONS	CAPACITY	EACH
3775 2130	7-Basket Dolly	29" x 20" x 61"	500 lb.	\$535.45
3775 1272	8-Basket Dolly	29" x 20" x 68-3/5"	500 lb.	556.45
3775 1273	9-Basket Dolly	29" x 20" x 76-2/5"	500 lb.	601.65
3775 4325	12-Basket Dolly	35-1/2" x 31-1/2" x 61-2/5"	500 lb.	567.95



▶ SEE PAGE 496

FOR FREEZER AND LOCKER PAPERS

PRICES ARE SUBJECT TO CHANGE • MINIMUMS MAY APPLY • VISIT OUR WEBSITE FOR CURRENT PRICING.

FREEZER TOTES, BASKETS AND DOLLIES

Aluminum 10-Platter Dolly

- Constructed of 1-inch square welded aluminum tubing. • Spacing: 4-3/4 inches apart.
- Holds ten, 18-inch x 26-inch platters.
- Four, 5-inch swivel casters, two with brakes.



NOTE: Platters sold separately. SEE RIGHT.

Heavy-Duty Aluminum 12-Platter Dolly

- Spacing: 5 inches apart.
- Four, 5-inch swivel casters.



Aluminum 20-Platter Dollies

- Stations are spaced 2-7/8 inches apart. Side load (C) or end load (D).
- Four, 5-inch swivel casters, two with brakes.
- Holds 20, 18-inch x 26-inch platters.



ITEM NO.	PRODUCT	DIMENSIONS	CAPACITY	EACH
3775 8394	A. 10-Platter Dolly	20" x 28-1/2" x 58"	300 lb.	\$411.55
3775 3003	B. 12-Platter Dolly	21-1/4" x 26-3/4" x 69-1/4"	500 lb.	432.55
3775 1332	C. 20-Platter, Side Load	28" x 20-1/4" x 69-1/2"	500 lb.	454.55
3775 1331	D. 20-Platter, End Load	28-1/2" x 20-1/4" x 69-1/2"	500 lb.	454.55



Aluminum Slant Display 7-Platter Dolly

Provides an attractive display with high product visibility.



- Designed to hold up to seven, 18-inch x 26-inch platters. Six slanted for display and one on the bottom base.
- Framework is made of 1-inch square wall tubing with all welded 1-5/8 inch angle racks.
- 22 inches L x 28-1/2 inches W x 70 inches H overall.
- Four, 5-inch stem type casters with polyolefin wheels, two with locks.

NOTE: Platters sold separately. SEE RIGHT.

Knock-Down Aluminum Deli Platter Dolly



- Designed to hold 12-inch x 30-inch platters on 1-5/8 inch angles with built-in easy slide ribs.
- Uprights are reinforced with a channel to help prevent breakage from the stem casters.
- Framework is constructed of 1-inch square x 0.07-inch wall tubing. Angle runners are constructed of 1-1/4 inch x 1-5/8 inch x 0.100 inch wall angle.
- Includes four, 5-inch swivel stem casters, 2 with brakes.
- All aluminum — will not rust.
- Capacity: 500 pounds when weight is evenly distributed.



Built-in easy-slide ribs allow platters to glide smoothly.

NOTE: Platters sold separately. SEE RIGHT.



ITEM NO.	PRODUCT	DIMENSIONS	RUNNER SPACING	F.O.B. FACTORY	
				SHIPPING WT.	EACH
3775 1346	6-Platter Capacity	15-1/4" x 30" x 39"	5"	24 lb.	\$375.85
3775 1348	10-Platter Capacity	15-1/4" x 30" x 69"	6"	43 lb.	401.05
3775 1347	12-Platter Capacity	15-1/4" x 30" x 69"	5"	45 lb.	478.75
0844 22191	Replacement Swivel Stem Caster (uses 2)				16.95
0844 22201	Replacement Swivel Stem Caster with Brake (uses 2)				19.95

ITEM NO.	PRODUCT	CAPACITY	EACH
3775 1137	Slant Display Dolly	400 lb.	\$454.55

PRICES ARE SUBJECT TO CHANGE • MINIMUMS MAY APPLY • VISIT OUR WEBSITE FOR CURRENT PRICING.

Platters

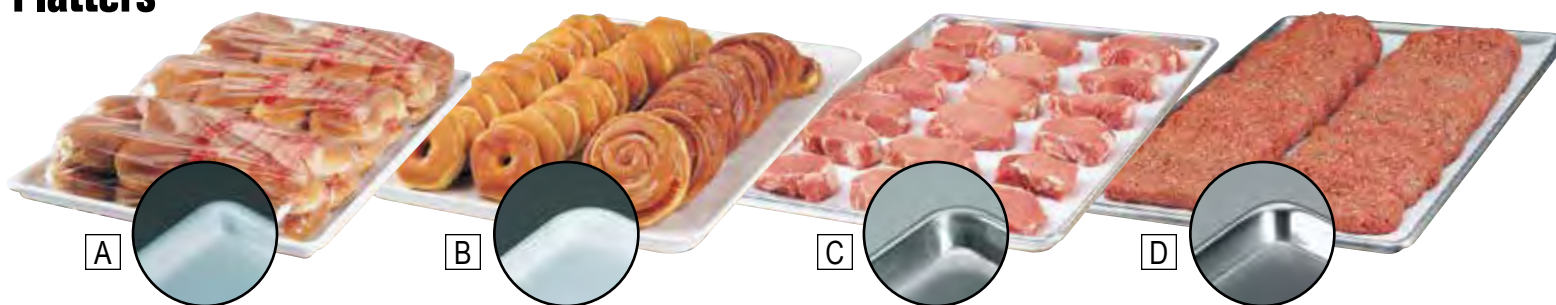

▶ 12 PER CASE.

ITEM NO.	PRODUCT	DIMENSIONS	EACH	
			1-11	12+
3195 29961	A. Polystyrene*	18" x 26" x 1-1/10"	\$15.85	\$14.85
1695 12241	Polystyrene*	12" x 24" x 3/4"	14.95	13.95
2432 18261	B. Fiberglass	18" x 26" x 1-1/10"	30.95	29.95
6387 00271	C. Aluminum	17-4/5" x 25-3/4" x 1-1/10"	19.85	18.85
3013 11641	D. Stainless Steel	18" x 26" x 1"	83.45	80.45
3013 21211	Stainless Steel	18" x 13" x 1"	54.55	51.55

*Not to be used with vegetable oil.

Knock-Down Stainless Steel Platter Dollies

- Four, 5-inch swivel casters, two with brakes.
- 1-inch square welded stainless steel.
- Dimensions: 20-1/4 inches L x 28 inches D.
- A. 10-Platter Dolly: 58 inches H overall.
- B. 20-Platter Dolly: 69-1/4 inches H overall.



NOTE: Platters sold separately. SEE ABOVE.

ITEM NO.	PRODUCT	CAPACITY	RUNNER SPACING	EACH
2990 2939	A. 10 Platter	300 lb.	4-3/4"	\$1,483.11
2990 2985	B. 20 Platter	500 lb.	2-7/8"	2,505.94

Mini Platter

- Designed specifically for case display of meats and other packaged foods.
- Heavy-duty plastic is lightweight and easy to clean.

NOTE: For steak papers, SEE BELOW.

▶ 12 PER CASE.

ITEM NO.	PRODUCT	DIMENSIONS	EACH	
			1-11	12+
4219 12301	E. Mini Platter	12-1/2" x 30" x 3/4"	\$12.75	\$11.75



Platter Liners

- Interleaved for serving and storage.
- Allows complete release from platters.
- Easy cleanup. • FDA compliant.



▶ 1,000 PER CASE.

ITEM NO.	PRODUCT	DIMENSIONS	CASE
7500 3991	Platter Liner Sheets	16-2/5" x 24-2/5"	\$60.95



Steak Paper

- Designed to keep meat juices locked in.
- FDA and USDA compliant.
- Sheet size: 9 inch x 12 inch.

▶ 1,000 PER CASE.

ITEM NO.	PRODUCT	CASE
1640 1912	Green	\$47.75
1640 0075	Black	63.55

Disposable Platter Dolly Cover

- Clear plastic cover protects product from dust and contaminants.
- Fits 10-platter dolly, as pictured, without dragging on ground.



▶ 50 COVERS PER ROLL.

ITEM NO.	PRODUCT	DIMENSIONS	ROLL
7500 1750	Dolly Cover	.52" x 80"	\$39.95

Knock-Down Aluminum Universal Pan Rack



- Easy clean bar slides are 3-3/4 inches wide.
- Holds 18-inch x 26-inch half and full sized sheet pans by the base of the pan.
- Holds 12-inch x 20-inch steam pans by the lip of the pan (sold separately).
- Strong and durable aluminum will not rust.
- Easy assembly, ships "knocked down".
- Includes 5-inch swivel stem casters.
- Dimensions: 22-3/4 inches L x 26 inches W x 73-3/4 inches H.



Holds platters and steam pans.

NOTE: Platters and steam pans sold separately. For steam pans, SEE RIGHT.

► SEE PAGE 203 For Platters

ITEM NO.	PRODUCT	SHIPPING WT.	F.O.B. FACTORY EACH
2510 3020	10-Pan Capacity	58 lb.	CALL FOR PRICING
2510 3021	15-Pan Capacity	76 lb.	
2510 3019	20-Pan Capacity	95 lb.	

Super Pan II® Steam Table Pans

- Pans are constructed of 22-gauge stainless steel to resist rust and corrosion.
- Reinforcer® corners won't bend and will withstand more impact than ordinary pans.
- Coved corners make scooping easier and allow for easy clean-up.
- Anti-jamming design keeps pans from sticking together when stored.
- Flat edges keep pans tight in steam table well to seal in heat.
- Optional covers have reinforced edges and fit securely to prevent spills during transport.



Optional pan cover.

► 6 PER CASE.

ITEM NO.	PRODUCT	DIMENSIONS	F.O.B. FACTORY EACH	
			1-5	6+
7160 00601	Half Pan	10-2/5" x 12-3/4" x 2-1/2"	\$28.95	\$27.95
7160 20241	Half Pan	10-2/5" x 12-3/4" x 4"	33.75	32.75
7160 00621	Half Pan	10-2/5" x 12-3/4" x 6"	49.05	47.05
7160 13221	1/3 Pan	6-9/10" x 12-3/4" x 2-1/2"	20.95	19.95
7160 13421	1/3 Pan	6-9/10" x 12-3/4" x 4"	34.05	33.05
7160 13621	1/3 Pan	6-9/10" x 12-3/4" x 6"	44.55	43.55
7160 63301	Full Pan	20-3/4" x 12-3/4" x 2-1/2"	42.85	41.85
7160 70971	Full Pan	20-3/4" x 12-3/4" x 4"	48.75	47.75
7160 00541	Full Pan	20-3/4" x 12-3/4" x 6"	75.95	74.95
7160 01361	Half Pan Cover		26.55	25.55
7160 01371	1/3 Pan Cover		24.45	23.45
7160 01471	Full Pan Cover		38.95	37.95

Aluminum Pan/Platter Dolly

- For use moving and storing 26 inch x 18 inch pans/platters.
- Includes four, 3-inch zinc-plated swivel caster rigs and hardware.
- Aluminum base will not rust.
- Shipping weight: 12-1/2 pounds.

► SEE PAGE 203 Platters Sold Separately



Corners are open for easy cleaning.

ITEM NO.	PRODUCT	DIMENSIONS	EACH
3775 8326	Aluminum Pan Dolly	18-2/5" x 26-1/2" x 6"	\$129.15



LEGGS
CUSTOM BLENDED SEASONINGS
A.C. Legg, INC.
Since 1982

► SEE PAGES 452 - 456

FOR SPICES AND SEASONINGS

www.bunzlpd.com

SIGN UP FOR OUR **eDEALS**

Exclusive offers not found anywhere else!

eDEAL SIGN-UP FORM AVAILABLE ON OUR WEBSITE.



Max System™ End-Loading Dolly

Impact-resistant structural web plastic cart and dolly are designed to work with platters and food boxes making them ideal for food preparation, transport, serving and storage tasks.



- USDA Meat and Poultry Group compliant.
- Certified to NSF Std.#2.
- 5-inch non-marking casters on swivel plate with two locking wheels.
- Heat-resistant, cart and dolly accommodate hot baking pans.
- Holds 18 platters or six, 18-inch x 26-inch food boxes.
- Dimensions: 28-3/4 inches x 23-3/4 inches x 67-9/10 inches.
- Weight: 82 pounds.



ITEM NO.	PRODUCT	EACH
1770 3320	End-Loading Dolly	\$714.00
3414 33201	Replacement Extrusion Kit, 2 Upper/2 Lower	167.95
3414 3317	Replacement Swivel Casters, 2 Reg, 2 w/Brakes & Hardware	136.95
3414 3322	Replacement Spanner Kit	25.95

▶ SEE PAGE 203

FOR PLATTERS



▶ SEE PAGE 464

FOR FOOD SLICER AND GRINDERS



Retractable Shelf, Side Load Cart

Locking casters keep the cart completely still when needed.

- Retractable shelf can hold 18-inch x 26-inch or 9-inch x 26-inch platters or pans.
- Top has built-in I-beam down the center constructed of 1-1/2-inch square wall tubing for extra support.
- Holds up to 6 platters (sold separately).
- Base is constructed of 1-1/2 square x 0.07-inch wall tubing. Top framework is constructed of 1-1/2 square x 0.07-inch wall tubing. Angle runners are constructed out of 1-1/4-inch x 1-5/8-inch x 0.1-inch angle.
 - The top and retractable shelf are constructed of 16-gauge stainless steel.
 - Shipping weight: 58 pounds.



Easy glide angle runners make sliding platters in and out an easy task.



Casters have total locking capabilities, making this unit completely rigid and non-moving when needed.

NOTE: Platters and food slicer sold separately.



Includes four, 5-inch platform-type, total-locking, swivel casters with sealed bearings.

ITEM NO.	PRODUCT	DIMENSIONS	F.O.B. FACTORY EACH
3775 9217	Retractable Shelf Prep Cart	28-2/5" x 30" x 20"	\$822.05
0844 22151	Replacement 5" Total Locking Casters		26.95

Large Food Boxes

- Shatter and crack-resistant containers with date control panels.
- NSF certified and commercial dishwasher safe.
- Record freshness dates with a grease pencil.
- Tight-fitting lids for longer shelf life.
- Assists in HACCP compliance.

White, DUR-X™ Food Boxes

▶ 6 PER CASE.

ITEM NO.	DIMENSIONS	CAPACITY	EACH	
			1-5	6+
1770 35071	18" x 12" x 3-1/2"	2 Gallon	\$18.95	\$17.95
1770 79721	18" x 12" x 6"	3-1/2 Gallon	23.95	22.95
1770 79681	18" x 12" x 9"	5 Gallon	29.95	28.95
1770 08561	26" x 18" x 6"	8.5 Gallon	38.95	37.95
1770 00281	26" x 18" x 9"	12-1/2 Gallon	57.95	56.95
1770 79641	26" x 18" x 15"	21-1/2 Gallon	79.95	78.95

White, DUR-X™ Lids

▶ 6 PER CASE.

ITEM NO.	DIMENSIONS	EACH	
		1-5	6+
1770 79661	Fits 26" x 18" Boxes	\$23.95	\$22.95
1770 79741	Fits 18" x 12" Boxes	13.95	12.95

Clear, CARB-X® Food Boxes

▶ 6 PER CASE.

ITEM NO.	DIMENSIONS	CAPACITY	EACH	
			1-5	6+
1770 33081	26" x 18" x 6"	8-1/2 Gallon	\$51.95	\$50.95
1770 79141	26" x 18" x 9"	12-1/2 Gallon	67.95	66.95
1770 33281	26" x 18" x 12"	16-3/5 Gallon	84.95	83.95

Clear, CARB-X® Lids

▶ 6 PER CASE.

ITEM NO.	DIMENSIONS	EACH	
		1-5	6+
1770 79181	Fits 26" x 18" Boxes	\$29.95	\$28.95



NOTE: Use a grease pencil to write directly on boxes!

▶ SEE PAGE 248

FOR MORE FOOD STORAGE CONTAINERS



Aluminum Universal Rack



Ideal for transporting various sized platters, trays, boxes and totes.

- Framework is constructed of 1-inch square x 0.07-inch wall tubing.
- Strong and durable, all welded aluminum construction will not rust.
- Shelves are constructed of 1/2-inch x 1-1/4-inch oval tubing.



Oval tubing shelves provide easy access.



Equipped with four, 5-inch swivel plate casters, two with brakes.



NOTE: Tote, freezer basket, platters and food boxes sold separately.

Food Box Dolly

- Fully-welded, aluminum construction.
- Holds 18-inch x 26-inch food boxes.



ITEM NO.	DIMENSIONS	EACH
2990 2986	8-1/2" x 15-1/4" x 33"	CALL FOR PRICING

ITEM NO.	PRODUCT	DIMENSIONS	SPACING BETWEEN SHELVES	SHIPPING WT.	F.O.B. FACTORY
					EACH
3775 1354	5-Shelf	16" x 32-1/2" x 42"	7-1/4"	37 lb.	\$368.55
3775 1356	6-Shelf	20-9/10" x 27" x 67"	10-1/2"	47 lb.	454.55
3775 1357	7-Shelf	28-1/2" x 32" x 69"	9"	60 lb.	761.25
3775 1358	8-Shelf	20-9/10" x 27" x 67"	7-1/4"	46 lb.	545.95
0844 22161	Replacement Heavy-Duty Caster, Plate Swivel (Uses 2)				19.95
0844 22171	Replacement Heavy-Duty Caster, Plate w/Brake (Uses 2)				24.95

Multi-Use Tray

These heavy-duty trays are perfect for extreme industrial applications that compromise injected or thermoformed trays.

- Straight sidewalls and no rims.
- Color: natural.
- Approved for food contact.
- Shipping weight: 9 pounds.

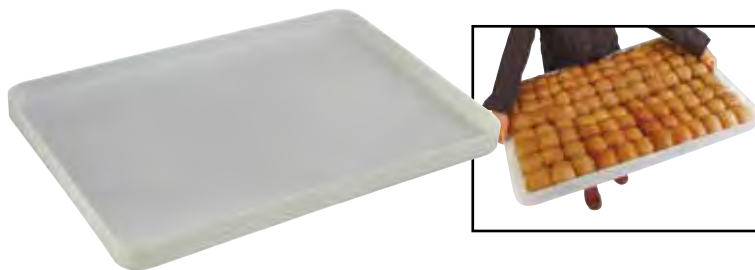

ITEM NO.	PRODUCT	DIMENSIONS	EACH
4743 20081	Multi-Use Tray	37-1/2" x 25" x 2-1/2"	\$69.95

Three Tier Tray Cart

Designed to hold three multi-use trays shown above.

- Includes 5-inch casters: two rigid and two swivel with brake.
- 1-1/4-inch square aluminum tubing construction.



ITEM NO.	PRODUCT	DIMENSIONS	EACH
3775 0472	Aluminum Cart	28-1/10" x 40-2/5" x 53-1/4"	\$784.25

Heavy-Duty Mixer Bowl Dolly

Maneuver easily from one station to the next.

- Guaranteed rust free.
- Constructed of 1-1/2-inch welded tubing.
- 5-inch platform type swivel casters.

NOTE: Mixing bowl NOT INCLUDED.



ITEM NO.	PRODUCT	DIMENSIONS	CAPACITY	SHIPPING WT.	EACH
3775 9936	A. Low-Profile Bowl Dolly	14" x 14" x 7-1/2"	80 qt.	15 lb.	\$205.75
3775 5636	B. High-Profile Bowl Dolly	26-3/4" x 20-3/4" x 28-3/4"	80 qt.	34 lb.	477.75

Dough Boxes

- Prevents crusting and reduces frequency of dough making.
- Rigid polycarbonate reinforced on all sides; boxes have rounded edges for safety.
- Boxes stack securely and are dishwasher safe.
- Boxes available in two depths.
- Optional cover available.



▶ 6 PER CASE.

ITEM NO.	PRODUCT	DIMENSIONS	EACH	
			1-5	6+
2432 63551	3" Dough Box	18" x 26" x 3"	\$41.95	\$40.95
2432 38111	6" Dough Box	18" x 26" x 6"	49.95	48.95
2432 63561	Cover		29.95	28.95

Aluminum Dough Box Dolly

- For use moving and storing dough boxes or platters.
- Corners are open for easy cleaning.
- Includes four, 3-inch zinc-plated swivel caster rigs and hardware.
- Aluminum base will not rust.
- Shipping weight: 12-1/2 pounds.



NOTE: Dough boxes sold separately. SEE ABOVE.

▶ SEE PAGE 203 Also Holds Platters



ITEM NO.	PRODUCT	DIMENSIONS	EACH
3775 8326	Aluminum Pan Dolly	18-2/5" x 26-1/2" x 6"	\$129.15



ProSave™ Ingredient System

Increase productivity, improve food safety and decrease supply costs.



- Scoop hook allows the scoop to be stored inside the bin and out of the product for quick access to each ingredient.
- By holding the scoop handle and securing it to the hook, hands do not touch the ingredients and the risk of cross-contamination is decreased.
- Integrated sliding lid for one handed access.
- See-thru lid slides along easy-glide track, to open.
- Assists in complying with FDA Food Code 30304.12.
- First in, first out (FIFO) fill compartment.



Scoop included and is easily stored inside.
10-gallon lid includes 2-cup scoop.
20-gallon lid includes 3-cup scoop.
32-gallon lid includes 4-cup scoop.

Rotating clear lid fits on 10-, 20-, or 32-gallon round containers (sold separately).



A
3-inch casters.



Scoop hook allows scoop to be easily accessible.



Scoop handle is held out of ingredient bin preventing cross-contamination.



Snap fit secures to base to make handling easier.



C

ITEM NO.	PRODUCT	DIMENSIONS	CAPACITY	FLOUR/SUGAR CAPACITY	SHIPPING WT.	EACH
1770 0017	A. 170 lb Slant-Front Storage Bin and 32 oz. Scoop	29-1/4" x 13.13" x 28"	20-1/2 Gallon	124 lb/158 lb	27.7 lb	\$420.95
1770 0018	200 lb Slant-Front Storage Bin and 32 oz. Scoop	29-1/2" x 15-1/2" x 28"	26-1/5 Gallon	154 lb/197 lb	32.7 lb	469.95
1770 0019	250 lb Slant-Front Storage Bin and 32 oz. Scoop	29-3/4" x 18" x 28"	30-4/5 Gallon	188 lb/240 lb	38.7 lb	489.95

ITEM NO.	PRODUCT	EACH
1770 9142	170 lb Replacement Lid and 32 oz. Scoop	\$150.95
1770 0800	200 lb Replacement Lid and 32 oz. Scoop	160.95
1770 0979	250 lb Replacement Lid and 32 oz. Scoop	160.95
3414 0004	Replacement 3" Swivel Casters	14.95
3414 0005	Replacement 3" Rigid Casters	13.95

▶ 6 PER CASE.

ITEM NO.	PRODUCT	EACH	
		1-5	6+
6387 03521	C. 10-Gallon Round Drum, White	\$18.85	\$17.85
6387 34301	20-Gallon Round Drum, White	27.25	26.25
6387 32301	32-Gallon Round Drum, White	35.65	34.65

ITEM NO.	PRODUCT	CAPACITY	EACH
1770 0343	B. 10 Gallon ProSave™ Lid, White	2-Cups	\$69.95
1770 0344	20 Gallon ProSave™ Lid, White	3-Cups	99.95
1770 0522	32 Gallon ProSave™ Lid, White	4-Cups	119.95

▶ 2 PER CASE.

ITEM NO.	PRODUCT	EACH	
		1	2+
6387 33171	D. Twist-on Dolly	\$46.45	\$45.45

More Drum Colors Available ▶ SEE PAGES 256 - 257



FIFO barrier aids in proper rotation of ingredients.



E

Integrated Safety Portioning Scoop and hook provide dedicated scoop storage for safe ingredient portioning.



F

Lid design provides one-handed access to ingredients while stacked on a shelf or under a prep table. Lid can swivel and rest under or over bin opening



► SEE PAGE 249
For Replacement Scoops

PRICES ARE SUBJECT TO CHANGE • MINIMUMS MAY APPLY • VISIT OUR WEBSITE FOR CURRENT PRICING.

ITEM NO.	PRODUCT	DIMENSIONS	CAPACITY	FLOUR/SUGAR CAPACITY	EACH
1770 5557	E. 100-Cup Shelf Storage Bin and 2-Cup Scoop	23-1/2" x 11-1/2" x 16-4/5"	6-1/4 Gallon	.25 lb/50 lb	\$189.95
1770 5558	F. 200-Cup Shelf Storage Bin and 2-Cup Scoop	23-1/2" x 19-1/5" x 16-4/5"	12-3/5 Gallon	.50 lb/100 lb	269.95

XTra™ Utility Cart

Versatile and attractive, perfect for high visibility situations.

- Three shelf unit. • Large shelves: 33 inches x 20 inches.
- Easy to clean and store.
- Color: off-white.



► SEE PAGES 188 -190
Totes Sold Separately

Flat Shelf Utility Cart

Perfect for transporting materials, supplies and heavy loads in almost any environment.

- Ergonomically designed push handle provides optimum hand placement and push height improving control and worker safety.
- Molded-in storage compartments, holsters, hooks and notches.
- Best-in-class casters to meet the most demanding environments.
- High density structural resin construction.
- Molded-in customizable fittings.
- Easy-access bottom shelf.
- Color: beige.



Convenient storage bin built into handle.



NOTE: More replacement parts available visit WWW.BUNZLPD.COM

ITEM NO.	PRODUCT	DIMENSIONS	CAPACITY	EACH
1770 0711	Utility Cart	20" x 40-3/5" x 37-4/5"	300 lb.	\$400.95
3414 5738	Replacement 4" Swivel Casters.			17.95
3414 00961	Replacement Top Shelf			87.95
3414 00951	Replacement Middle Shelf			129.95
3414 00941	Replacement Bottom Shelf			89.95
3414 00931	Replacement Aluminum Upright Kit (8 pieces).			62.95
3414 00615	Replacement Handle Kit (2x Handles)			115.95

ITEM NO.	PRODUCT	DIMENSIONS	CAPACITY	EACH
1770 0702	Small, Utility Cart	37-9/10" x 19" x 33"	500 lb.	\$329.95
1770 0525	Large, Utility Cart.	43-9/10" x 25-9/10" x 33"		382.95
3414 0058	Replacement Hardware Kit			2.95
0844 01861	Replacement 5" Rigid Caster			15.95
0844 01871	Replacement 5" Swivel Caster			17.95

Heavy-Duty Utility Carts

Heavy-duty structural foam plastic construction won't rust, dent, chip or peel.

- Molded-in storage compartments, holsters, hooks and notches.
- Ergonomically designed push handle for greater maneuverability.
- High density structural resin construction.
- Easy access bottom shelf.
- Includes casters designed for the most demanding environments.



Molded-in storage compartment in handle.



ITEM NO.	PRODUCT	DIMENSIONS	COLOR	CAPACITY	EACH
1770 0090	Standard Shelf Cart	39" x 17-9/10" x 33-1/4"	Black	500 lb.	\$313.95
1770 4500	Standard Shelf Cart	39" x 17-9/10" x 33-1/4"	Beige	500 lb.	313.95
1770 2093	Large Shelf Cart	45-1/4" x 25-9/10" x 33-1/4"	Black	500 lb.	346.95
1770 2089	Large Shelf Cart	45-1/4" x 25-9/10" x 33-1/4"	Beige	500 lb.	346.95
1770 4550	Extra Large Shelf Cart	55" x 26" x 33-1/4"	Black	750 lb.	577.95

Replacement Parts

ITEM NO.	PRODUCT	EACH
0844 01861	Replacement 5" Rigid Caster	\$15.95
0844 01871	Replacement 5" Swivel Caster	17.95
3414 00631	Cart Leg, Black	16.95
3414 0058	Replacement Hardware Kit	2.95
3414 00901	Kit w/4-Casters	49.95

3-Shelf Utility Carts



- Colored carts help facilitate the organization of products, cleaning tools and equipment.
- Casters constructed of resin help eliminate added noise, unlike metal carts.
- Cart contains two convenient ergonomic handles.
- Smooth surface is easy to clean.



NOTE: Replacement shelves available.
WWW.BUNZLPD.COM

ITEM NO.	PRODUCT	DIMENSIONS	CAPACITY	EACH
1770 2492	Red	33-3/5" x 18-3/5" x 37-3/4"	200 lb.	\$357.00
1770 3426	Black	33-3/5" x 18-3/5" x 37-3/4"	200 lb.	357.00
3414 00605	Replacement Aluminum Upright Kit (8 pieces)			46.95
3414 5738	Replacement 4" Swivel Casters			17.95

Heavy-Duty Metal Utility Carts



Easy to handle cart can be maneuvered through corridors and doorways without difficulty.



- Shelves adjust on 1 inch increments for added versatility.
- Constructed of powder-epoxy over zinc-chromate electroplating.
- Antimicrobial agents protect cart from bacteria, mold and mildew.
- Welded at all contact points.
- Four, 5-inch wheels with swivel casters.
- Two shelves, overall height: 39 inches.



ITEM NO.	PRODUCT	CAPACITY	F.O.B. FACTORY EACH
5268 2467	24" x 36"	1,200 lb.	\$241.95
5268 2461	24" x 48"	1,200 lb.	273.95
5268 2460	24" x 60"	1,200 lb.	294.95
5268 00061	Replacement Casters (Set of 4)		90.00

Solid Shelf Aluminum Equipment Stands

Constructed with a marine edge to contain spills.

- Load rating is 400 pounds per shelf.
- Use as a stationary unit or add optional caster set and turn stand into a mobile unit.
- Shelves are constructed of 0.040 inch aluminum with 1-1/2-inch square x 0.07-inch wall tube reinforcement.
- Posts are constructed out of 1-5/16-inch aluminum pipe with a 5/32 inch wall thickness.
- Ideal for use with scales, label printers, vacuum machines, patty machines, slicers, tenderizer or mixers.

24 Inch Height

30 Inch Height w/Casters

ITEM NO.	SHELF SIZE	SHIPPING WT.	EACH
3775 5100	18" x 24"	20 lb.	\$273.95
3775 5101	18" x 30"	23 lb.	273.95
3775 5102	18" x 36"	23 lb.	280.25
3775 5103	20" x 24"	23 lb.	302.35
3775 5104	20" x 30"	25 lb.	317.05
3775 5105	20" x 36"	26 lb.	298.15



Edge built to contain spills.

30 Inch Height

36 Inch Height w/Casters

ITEM NO.	SHELF SIZE	SHIPPING WT.	EACH
3775 5110	18" x 24"	21 lb.	\$284.45
3775 5111	18" x 30"	24 lb.	284.45
3775 5112	18" x 36"	24 lb.	299.15
3775 5113	20" x 24"	24 lb.	314.95
3775 5114	20" x 30"	25 lb.	313.85
3775 5115	20" x 36"	26 lb.	318.05

36 Inch Height

42 Inch Height w/Casters

ITEM NO.	SHELF SIZE	SHIPPING WT.	EACH
3775 5120	18" x 24"	18" x 24"	\$307.65
3775 5121	18" x 30"	18" x 30"	307.65
3775 5122	18" x 36"	18" x 36"	307.55
3775 5123	20" x 24"	20" x 24"	339.15
3775 5124	20" x 30"	20" x 30"	321.25
3775 5125	20" x 36"	20" x 36"	321.25



Stand shown with optional caster kit.



Add the optional caster kit for mobile stand conversion. Includes: four, 5-inch all black polyolefin wheels with 1-inch swivel, stem-type casters, each with locking brake.

Caster Kit



ITEM NO.	PRODUCT	EACH
0844 39005	Four Caster Kit	\$85.95

A. Folding Utility Cart

- Two high-end handles prevent merchandise from sliding.
- Aluminum construction resists rust and corrosion.
- Two 6-inch rigid polyurethane casters and four, 5-inch swivel polyurethane casters.
- Shipping weight: 74 pounds.



Folds down to maximize available storage space.



A

B. Folding Solid Deck Bulk Delivery Truck

Ideal for transporting heavy loads.

- Two high-end handles prevent merchandise from sliding.
- Aluminum construction resists rust and corrosion.
- Six platform casters, 4 rigid and 2 swivel.



NOTE: Choose from 6-inch or 8-inch casters.

B

Six wheel design allows the unit to swivel on an axis within its own radius.



Cart can be folded and stored upright to maximize available storage space.

ITEM NO.	PRODUCT	UNFOLDED DIMENSIONS	FOLDED DIMENSIONS	CAPACITY	EACH
3775 6856	A. Folding Utility Cart	16" x 64" x 64-7/10"	16" x 14" x 64-3/4"	1,500 lb	\$648.85
3775 9326	B. Folding Solid Deck Cart, 6" Casters	18" x 61" x 61"	18" x 15" x 61"	1,200 lb	896.65
3775 9325	Folding Solid Deck Cart, 8" Casters	18" x 63" x 61"	18" x 17" x 61"	1,200 lb	928.15

PRICES ARE SUBJECT TO CHANGE • MINIMUMS MAY APPLY • VISIT OUR WEBSITE FOR CURRENT PRICING.

Heavy-Duty Platform Trucks

Ideal for moving large, heavy, oversized loads in a variety of environments.

- Exclusive, precision-engineered resin and metal composite structure provides maximum load support.
- Non-marking polyolefin casters are impact and chemical resistant and won't flat-spot under static loads.
- Powder-coated steel creates a hard finish that is tougher than conventional paint.
- Textured deck surface reduces load slippage. • Perimeter deck channel retains small items.
- Variable grip-height improves control and worker safety.
- Retainer clips prevent unintended handle removal.



▶ SEE PAGE 573

FOR OUR TRADEMASTER® MOBILE WORK CENTER

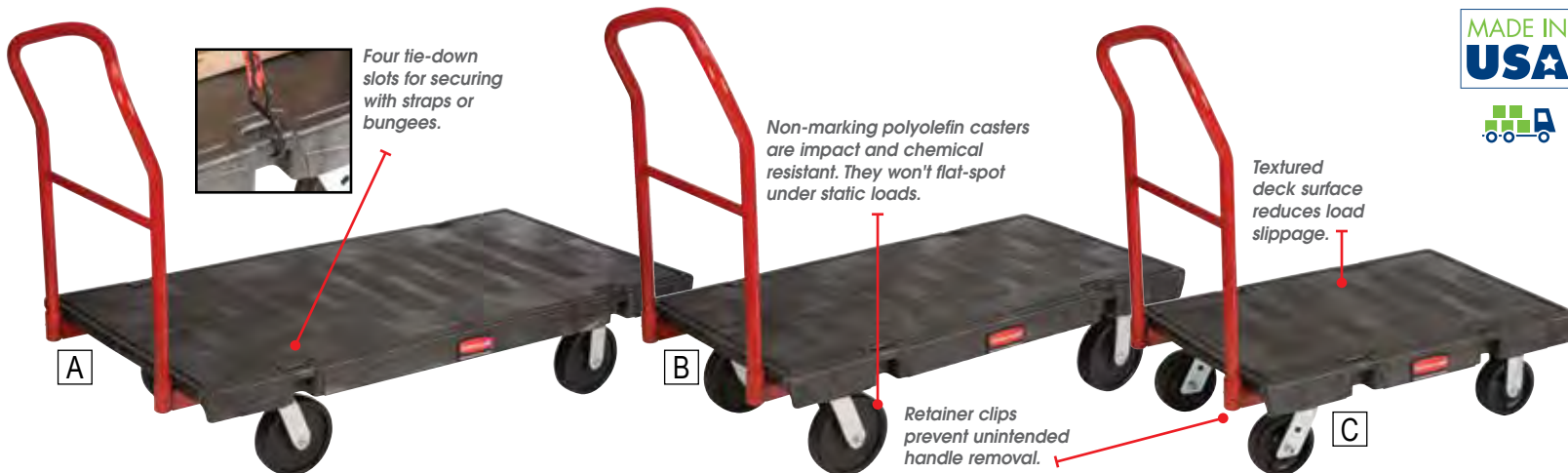

MADE IN USA



ITEM NO.	PRODUCT	CAPACITY	SHIPPING WT.	EACH
1770 0171	A. 30" x 60"	2,000 lb	100 lb.	\$879.95
1770 4442	B. 24" x 48"	2,500 lb	.80 lb.	729.95
1770 4414	C. 24" x 36"	2,000 lb	.63 lb.	679.95

Triple Trolley Deck Cart

Three ways to keep your work moving.

- Three-position handle lets user push, pull, or fold flat for use as a dolly.
- Moves on easy-to-push 5-inch heavy-duty casters
- Holds up to 500 pounds, yet weighs less than 25 pounds.
- Made from a durable structural foam which will not rust, dent or bend.
- Back wheels pivot for easy and smooth maneuvering around corners.
- Large non-skid surface: 32-1/2 inches x 20-1/2 inches.
- Folds down for easy transport and storage.
- Color: black.

MADE IN USA

▶ SEE PAGE 257
Drums Sold Separately



ITEM NO.	PRODUCT	DIMENSIONS	CAPACITY	EACH
1770 4405	Triple Trolley Deck Cart	32-1/2" x 20-1/2"	500 lb.	\$239.95
0844 01861	Replacement 5" Rigid Caster			15.95
0844 01871	Replacement 5" Swivel Caster			17.95

Replacement Parts

ITEM NO.	PRODUCT	EACH
3414 01021	Replacement Valco Clip for Platform.	\$3.95
3414 01031	Replacement Truck Hardware Kit	10.95
3414 00811	Replacement 24" Crossbar Handle.	70.95
3414 00991	Replacement 30" Crossbar Handle.	70.95
3414 00891	Replacement 40" Crossbar Handle.	110.95
3414 00881	Replacement 40" x 70" Platform Deck.	299.95

NOTE: More replacement parts available visit WWW.BUNZLPD.COM

Stainless Steel Platform Truck

Built to last a lifetime!

- 14-gauge stainless steel truck is ideal for use in wet or corrosive areas.
- One-piece platform with 2 inch turned down edges is rust-proof and completely sanitary, no crevices to trap dirt.
- Includes two swivel and two rigid casters with rugged 8-inch white plastic wheels in the standard four-corner configuration.
- Handle is removable.
- Shipping weight: 102 pounds.

MADE IN USA

ITEM NO.	DIMENSIONS	CAPACITY	EACH
2990 3369	30" x 60"	1,200 lb.	CALL FOR PRICING



Channel Deck Platform Truck

Rounded nose helps decrease damage to walls and doors.

- Constructed with tube frame and a channel deck to help minimize product fall through.
- Easy-to-grip 1-5/8 inch diameter pipe handle removes easily.
- Equipped with two rigid and two swivel, heavy-duty 8 inch diameter casters with grease zerks in swivel and hub. Replacement casters available.
- Strong and durable aluminum will not rust.
- Handle length: 44-1/2 inches.
- Choose from 5 sizes of trucks.



ITEM NO.	PRODUCT	SHIPPING WT.	CAPACITY	F.O.B. FACTORY EACH
3775 9320	20" x 36" Truck	47 lb.	2,000 lb	\$500.75
3775 9321	20" x 48" Truck	48 lb.		535.45
3775 0322	20" x 60" Truck	53 lb.		530.15
3775 9323	30" x 48" Truck	57 lb.		625.75
3775 9324	30" x 60" Truck	61 lb.		741.25
0844 22121	Replacement Swivel Caster (Requires 2)			46.95
0844 22141	Replacement Rigid Caster (Requires 2)			68.95

Stainless Steel Folding Handle Platform Truck



- 304 stainless handle and platform.
- 5-inch rubber non-marking caster wheels.
- Capacity: 770 pounds.
- Platform Size: 22-1/2 inches x 34 inches.
- Handle Height: 34 inches.



ITEM NO.	PRODUCT	SHIPPING WT.	CAPACITY	EACH
7447 0458	22-1/2" x 34" Truck	37 lb.	770 lb.	\$750.95
0844 22121	Replacement Swivel Caster (Requires 2)			46.95
0844 22141	Replacement Rigid Caster (Requires 2)			68.95

Aluminum Stock Truck

Transport heavy loads from back room to sales floor.

- All-aluminum truck is light-weight and easy to maneuver, yet sturdy enough to let you load heavy boxes.
- Unit fits down most aisles, rounded front protects walls.
- Folds compactly to store conveniently and safely.
- Six heavy-duty casters.
- Shipping weight: 50 pounds.



ITEM NO.	PRODUCT	DIMENSIONS	CAPACITY	EACH
3775 3796	Aluminum Stock Truck	63-1/2" x 18" x 62"	1,500 lb	\$535.45

Aluminum Boxed-Beef Shelf Truck



- All welded, heavy-duty corrosion-resistant aluminum alloy.
- Strong 1-1/4-inch x 2-1/4-inch cross members.
- Load capacity: 1,800 pounds.
- Shipping weight: 70 pounds.
- Two rigid and two swivel 6-inch casters with white poly wheels.



ITEM NO.	DIMENSIONS	CAPACITY	EACH
3775 3100	27" x 63" x 70"	1,800 lb	\$739.15

PRICES ARE SUBJECT TO CHANGE • MINIMUMS MAY APPLY • VISIT OUR WEBSITE FOR CURRENT PRICING.

Hand Trucks, 600 Pound Capacity

A. Economy P-Handle Truck

7-1/2-inch x 14-inch nose plate.

- P-handle design allows for one-handed operation.
- 16-gauge frame.

B. Heavy-Duty Truck

9-inch x 14-inch nose plate.

- Dual handles and molded grip for improved control and stability.
- Curved back, center support for better handling around objects.
- Rugged, all-welded 1-inch OD 14-gauge steel frame.

ITEM NO.	PRODUCT	DIMENSIONS	CAPACITY	SHIPPING WT.	EACH
0844 1001	A. Economy P-Handle Truck	51-1/2" x 21-1/2"	600 lb.	26 lb.	\$164.95
0844 1002	B. Heavy-Duty Dual Handle Truck	46" x 13" x 17"	600 lb.	33 lb.	186.95

Full pneumatic 10-inch ball bearing wheels make this truck great for outdoor use.



Drum Hand Truck, 800 Pound Capacity

Two trucks in one: utility of both a hand truck and drum truck.

- Constructed of 1-inch heavy-duty pipe frame.
- Curved frame accommodates 5-gallon pails and kegs; chime hook works with 30- and 55-gallon drums.
 - 8-inch x 2-inch cast iron wheels with molded on rubber and wheel guards; 3/4-inch axle and bearing.
 - Nose plate: 8 inches x 14 inches.



WESCO Industrial Products, Inc.

MADE IN USA



ITEM NO.	PRODUCT	DIMENSIONS	CAPACITY	SHIP WT.	EACH
7447 0349	Drum Hand Truck	48" x 20-1/2"	800 lb.	42-1/2 lb	\$281.95
7447 0576	Replacement Wheel				60.95

Aluminum Hand Truck Pallet

Ideal for moving small cases and bags of product.

- Designed to reduce the unstacking of product — put the product on the pallet once and move it and leave it without having to unstack the product off the hand truck.
- For use with any hand truck with a nose plate length of 8 inches or longer.
- Heavy-duty aluminum wall tubing construction.
- Shipping Weight: 11 pounds.
- Capacity: 400 pounds.

NOTE: This pallet works with Bunzl hand trucks #0844 1002 and 7447 0349, sold separately. SHOWN ABOVE.

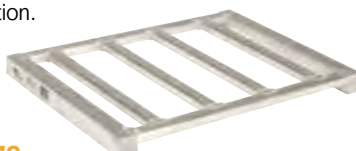

MADE IN USA

ITEM NO.	PRODUCT	DIMENSIONS	EACH
3775 0010	Hand Truck Pallet	15-1/2" x 21" x 1-1/2"	\$93.35



Scan this QR code with your mobile device to view a video of the features of this product.

▶ SEE PAGE 223

FOR COOLER/CURB RAMP



Dual Handle Drum Hand Truck, 1,000 Pound Capacity

- Self-standing, heavy-duty, 1-inch structural pipe frame with all joints double welded.
- Twin handles provide stable, easy wheeling for heavy loads.
- Floating axle reduces effort required to break over and balance load.
- Handles 55-gallon drums; chime hook can be stored at top of frame for easy use
- Replaceable hard faced double-beveled nose prongs.



10-inch x 2-1/2-inch molded-on rubber wheels over cast iron center

WESCO Industrial Products, Inc.

MADE IN USA



ITEM NO.	DIMENSIONS	CAPACITY	SHIPPING WT.	EACH
7447 4003	61" x 23-3/4"	1,000 lb.	74 lb.	\$546.95

Greenline Economy Convertible 2-in-1 Hand Truck

Converts between two- and four-wheel positions.

- Heavy-duty tubular steel construction.
- Lever activated position conversion.
- Bed size: 13-3/4 inches x 48 inches.
- 10-inch x 2-3/4-inch solid rubber wheels. 5-inch x 1-3/8-inch moldon polyurethane swivel casters.
- Includes wheel guards.
- Capacities:
 - 2 wheels: 700 pounds;
 - 4 wheels: 800 pounds.
- Nose plate: 18 inches x 8-1/2 inches.

WESCO Industrial Products, Inc.

Folds upright for easy storage when not in use.



ITEM NO.	PRODUCT	DIMENSIONS	SHIP WT.	EACH
7447 0639	Convertible Hand Truck	19-1/2" x 58" x 18"	77 lb.	\$297.95
7447 84791	Replacement Rubber Wheel			30.95
7447 21401	Replacement Caster			30.95

Structural Foam Tilt Trucks

- Durable structural foam one-piece plastic construction eliminates need for metal frame that can harbor bacteria.
- "Constant force" design makes it easier and safer to go from a kneeling position to the full dumping position.
- Fits through standard commercial doorways and onto elevators easily.
- Ergonomic steering handle provides utmost control when maneuvering and dumping.
- Secondary handle on underside of truck provides further control when dumping contents.
- Non-marking, casters are inset to prevent damage to walls, doors and fixtures.
- Available in three different degrees of ruggedness and four different capacities.
- Color: black.



ITEM NO.	PRODUCT	DIMENSIONS	CAPACITY	EACH
1770 0095	A. Utility-Duty.	53-1/5" x 26-9/10" x 33-9/10"	450 lb/0.5 cu. yd.	\$683.00
1770 9311	B. Standard-Duty.	57-2/5" x 26-9/10" x 33-9/10"	850 lb/0.5 cu. yd.	795.00
1770 1012	Standard-Duty.	64-1/2" x 30-1/5" x 38"	600 lb/0.75 cu. yd.	919.00
1770 1015	Standard-Duty.	64-1/2" x 30-1/5" x 38"	1,000 lb/0.75 cu. yd.	1,676.95
1770 1500	Standard-Duty.	70-4/5" x 33-1/2" x 42-1/5"	1,250 lb/1 cu. yd.	1,377.95
1770 1601	C. Heavy-Duty.	70-4/5" x 33-1/2" x 42-1/5"	2,100 lb/1 cu. yd.	1,377.95
1770 2200	Lid for 0.5 cu. yd. (For Item #'s 1770 0095 and 1770 9311).		F.O.B. FACTORY	\$199.95
1770 0351	Lid for 0.75 cu. yd. (For Item #'s 1770 1012 and 1770 1015).		F.O.B. FACTORY	281.95
1770 1704	Lid for 1 cu. yd. (For Item #'s 1770 1500 and 1770 1601)		F.O.B. FACTORY	296.95
3414 01041	Replacement Handle Bracket.			5.95
3414 1111	Replacement 12" Wheel			104.95
3414 1112	Replacement 4" Non-Marking Plate Swivel Caster			29.95



Scan this QR code with your mobile device to view a video of the features of these Tilt Trucks.

Poly Tilt Truck

- Well balanced and easy to maneuver and tilt due to 12-inch load wheel and two rear swivel casters.
- Light-weight poly truck is easily transported and dumped by a single person.
- Smooth and seamless interior is easy to clean.
- Poly trucks will not pit or corrode like steel.

NOTE: Custom colors available. CALL FOR DETAILS.

Replacement Parts

ITEM NO.	PRODUCT	EACH
3414 1307	Repl. Black Frame (For 1/2 cu. yd. Truck)	\$357.95
3414 30541	Repl. Black Handle	63.95
3414 1305	Repl. 10" Wheel (For 1/2 cu. yd. Truck)	99.95
3414 0054	Repl. 3-1/2" Swivel Caster w/Hardware	39.85



ITEM NO.	PRODUCT	COLOR	DIMENSIONS	CAPACITY	EACH
1770 1301	Tilt Truck	Black	60-1/2" x 28" x 38.6"	850 lb/0.5 cu. yd.	\$1,377.95
1770 1321	Tilt Truck	Black	72-1/4" x 33-1/2" x 43-3/4"	2,100 lb/1 cu. yd.	1,837.95
1770 13231	Lid	Black			329.95

Heavy-Duty Tilt Truck

Available in 16 custom colors.

- Durable polyethylene construction is highly dent- and crack-resistant.
- Free of cracks, crevices or joints which may harbor dirt and bacteria.
- Sturdy full perimeter black powder-coated steel underframe.
- Trucks are nestable for convenient storage.
- Industrial-quality, easy rolling casters are joined to the molding with sturdy bases.

Also available in Pink, Wine, Red, Powder Blue, Cadet Blue, Royal Blue, Bright Lemon Yellow, Brilliant Orange, Chocolate Brown, Lime, Jade Green, Forest Green, Honey Gold, Beige, Metallic Silver and Purple.



Optional split-hinge lid available.



41-1/2 inches deep.

ITEM NO.	PRODUCT	COLOR	DIMENSIONS	CAPACITY	F.O.B. FACTORY EACH
2345 0307	Tilt Truck	Gray	79-1/2" x 40-1/2" x 48-1/2"	2,000 lb/1.5 cu. yd.	\$999.00
2345 0308	Tilt Truck Split-Hinge Lid				219.95

Molded Plastic Utility Truck

Won't rust or corrode, won't splinter or dent, easy to clean.

- Domed, hinged lid conceals and protects loads without decreasing capacity.
- Metal frame design provides durable support.
- Ideal for wet environments.
- Diamond caster pattern is easy to maneuver.

Custom colors available in blue and brown.

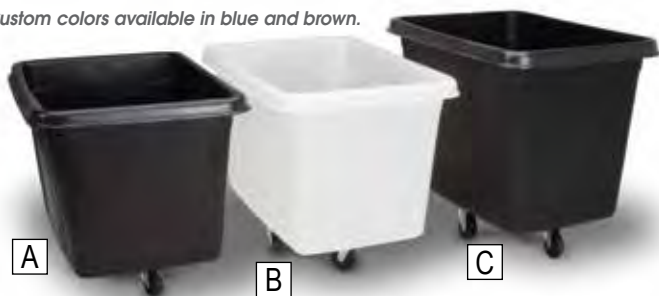

NOTE: More replacement parts available visit WWW.BUNZLPD.COM

ITEM NO.	PRODUCT	COLOR	DIMENSIONS OD	CAPACITY	F.O.B. FACTORY EACH
1770 4607	8 cu. ft. Truck	Black	36-2/5" x 26" x 28-1/4"	300 lb.	\$498.95
1770 4608	8 cu. ft. Truck	White	36-3/10" x 25-1/2" x 28-3/10"	300 lb.	498.95
1770 4614	14 cu. ft. Truck	White	44-1/10" x 31" x 32-1/2"	500 lb.	693.95
1770 4629	14 cu. ft. Truck	Black	44-1/10" x 31" x 32-1/2"	500 lb.	653.95
1770 4621	16 cu. ft. Truck	Black	44-1/2" x 31" x 37"	500 lb.	956.95
1770 4616	16 cu. ft. Truck	White	44-1/4" x 30-1/2" x 37-3/10"	500 lb.	728.95
1770 03351	Lid for 8 cu. ft.	Black	38-2/5" x 25-3/4" x 8-1/2"		259.95
1770 4628	Lid for 14 and 16 cu. ft.	Black	44-1/10" x 31" x 8-1/2"		299.95

Replacement Parts

ITEM NO.	PRODUCT	EACH
3414 0049	Repl. 8-cu. yd. Metal Frame	\$117.95
3414 4613	Repl. 14-cu. yd. Metal Frame	137.95
3414 01001	Repl. 16-cu. yd. Metal Frame	188.95
3414 4608	Repl. 4" Rigid Caster (for 8-cu. yd. Truck)	32.95
3414 4607	Repl. 4" Swivel Caster (for 8-cu. yd. Truck)	32.95
3414 4615	Repl. 5" Rigid Caster (for 14/16-cu. yd. Truck)	35.95
3414 4614	Repl. 5" Swivel Caster (for 14/16-cu. yd. Truck)	37.95



Laundry Truck

Uniquely designed to hold bulk fabrics and linens.

- Durable polyethylene construction is highly dent- and crack-resistant.
- Free of cracks, crevices or joints which may harbor dirt and bacteria.
- Easy to clean and sanitize.
- Industrial quality, easy rolling casters are joined to the molding with sturdy bases.
- 48 cubic foot capacity; 59 inches deep.
- Dimensions: 48 inches L x 28-1/2 inches W x 66-1/2 inches H.
- Shipping weight: 127 pounds.

ITEM NO.	PRODUCT	F.O.B. FACTORY EACH
2345 0072	Laundry Truck	\$799.00



▶ SEE PAGE 85

FOR LAUNDRY BAGS, DETERGENT AND PINS





Molded stacking stops in each lid.

Single-Wall Poly Combo Bins

Optional snug-fitting lids permit stacking when bins are full, nest bins to save storage space when empty.

- Seamless, easy-to-clean and corrosion-resistant.
- Lighter and less expensive than stainless steel.
- Two-way pallet entry. Fit two wide for maximum trailer cube.
- Heavy-duty roto-molded polyethylene bins are extra thick at corners and floor contact points.
- Custom identification can be molded-in or stenciled-on bins for an additional charge.



NOTE: Optional polyethylene dust cover is light-weight and non-stackable. Optional combo bins have a 1-1/2-inch bottom drain available. CALL FOR DETAILS.

ITEM NO.	CAPACITY	CUBIC FT.	OUTSIDE DIMENSIONS	SHIPPING WT.	F.O.B. FACTORY EACH
0021 0293	250 Gallon	34.50" x 42" x 36"	100 lb.	CALL FOR PRICING
0021 8294	275 Gallon	37.50" x 42" x 39"	105 lb.	
0021 8295	385 Gallon	45.50" x 42" x 52"	125 lb.	
0021 0296	Stacking Lid.			35 lb.	
0021 8297	Polyethylene Dust Cover			21 lb.	
0021 0110	Rubber Drain Plug for Bins w/Drain				\$10.45

Poly Storage Combo Bins with Replaceable Pallet

- Double-thick base protects against damage to bottom.
- Top rim is reinforced for added protection from impact damage.
- Optional snug-fitting lids permit stacking when bins are full.
- Optional polyethylene dust cover is light-weight and non-stackable.
- Fit two wide for maximum trailer cube.
- Four-way entry, replaceable pallet.
- Nest bins when empty.



Flat-bottom makes cleaning quick and easy with no cavities for bacteria to grow.

NOTE: Optional bottom drain available.

ITEM NO.	CAPACITY	CUBIC FT.	OUTSIDE DIMENSIONS	SHIPPING WT.	F.O.B. FACTORY EACH
0021 5304	225 Gallon	34.50" x 42" x 36"	108 lb.	CALL FOR PRICING
0021 5305	250 Gallon	37.50" x 42" x 39"	113 lb.	
0021 5302	360 Gallon	45.50" x 42" x 52"	135 lb.	
0021 5307	400 Gallon	45.50" x 42" x 55"	140 lb.	
0021 5309	Stacking Lid.			35 lb.	
0021 5310	Polyethylene Dust Cover			21 lb.	
0021 5308	Replacement Pallet			35 lb.	



Removable pallet can be easily replaced if damaged.



MonsterCombo® Bins

Versatile, multi-use bulk containers are ideal for in-plant processing, food handling or over-the-road hauling capacities.

- Rotationally molded FDA-CFIA approved polyethylene.
- Replaceable 4-way base with smooth flat interior is easy to clean.
- Standard footprint: 48 inches x 44 inches. Available in heights from 36 inches to 45 inches.
- Nest bins when empty to save storage space.
- Four-way fork lift and pallet jack entry.
- Extra thick at corners and floor to resist impact and wear.
- Reinforced top edge adds strength and resists splitting
- Optional drains available.



Smooth flat interior is easy to clean.

NOTE: Custom colors available. CALL FOR DETAILS.



NOTE: Optional bottom drain available.

ITEM NO.	CAPACITY	CUBIC FT.	OUTSIDE DIMENSIONS	SHIPPING WT.	F.O.B. FACTORY EACH
0021 2902	229 Gallon	31.48" x 44" x 36"	132 lb.	CALL FOR PRICING
0021 2962	251 Gallon	34.48" x 44" x 39"	139 lb.	
0021 2910	273 Gallon	37.48" x 44" x 42"	152 lb.	
0021 2963	296 Gallon	40.48" x 44" x 45"	153 lb.	



SHOP bunzlpd.com 24/7



Where you can find out what's on sale,
find updated product information,
reviews and pricing.

Need Help?
Chat With Us
Online!



STAY CONNECTED WITH US:



Angled Dump Tubs

- Durable, one piece high-density polyethylene.
- Smooth interior for easy cleaning.
- Full, lidded dump tubs stack securely for transporting, freezing and storing.
- Empty tubs nest for space conservation.
- Tubs meet all USDA specifications and are commonly used for meat, seafood, poultry, commercial fishing, confectionery, bakery and grain applications.
- Capacity: 800 pounds.
- Dimensions: 54-3/5 inches L x 32 inches W x 21-7/10 inches H.
(36 inches high with regular undercarriage, 28 inches with low undercarriage).



NOTE: Dump tub, lid and undercarriages all sold separately.



ITEM NO.	PRODUCT	COLOR	SHIPPING WT.	F.O.B. FACTORY EACH
5281 6901	A. Dump Tub	White	28 lb.	\$348.95
5281 0292	Dump Tub	Green.	28 lb.	348.95
5281 0141	Dump Tub	Blue	28 lb.	348.95
5281 0142	Dump Tub	Red	28 lb.	348.95
5281 0254	Dump Tub	Yellow	28 lb.	348.95
5281 6902	B. Tub Lid	White	15 lb.	177.95
5281 02901	Tub Lid	Green.	15 lb.	219.95
5281 02891	Tub Lid	Blue	15 lb.	219.95
5281 02881	Tub Lid	Red	15 lb.	219.95
5281 02861	Tub Lid	Yellow	15 lb.	219.95
5281 6903	C. Regular Undercarriage		69 lb.	629.95
5281 6904	D. Low Undercarriage		105 lb.	618.95

Stainless Steel Vat

- Heavy-duty welded, 12-gauge stainless steel construction with rolled and welded rim.
- Interior welds are ground smooth for easy cleaning.
- 7-inch legs are constructed of 11-gauge stainless steel and are completely closed to meet USDA requirements.
- Drain constructed into vat, plug not included.
- Dimensions: Outside: 39 inches L x 51 inches W x 43 inches H.
Inside: 36 inches L x 47-1/2 inches W x 36 inches H.



NOTE: Optional drain plug available. SEE BELOW.

ITEM NO.	PRODUCT	CAPACITY	SHIPPING WT.	F.O.B. FACTORY EACH
2990 1619	Vat	2,000 lb	250 lb.	CALL FOR PRICING

Aero-Tote Container

High-density polyethylene walls offer protection for all kinds of food products.

- Lid made of thick, rigid polyethylene allowing for column stacking.
- Versatile modular design allows for secure nesting, stacking and in-plant moving with a forklift.
- Pallet easily snaps on and off.
- Ribbed bottom for drainage.



NOTE: Tote, lid and pallet all sold separately.



Totes nesting.



Totes stacked.

ITEM NO.	PRODUCT	OUTSIDE DIMENSIONS	SHIP WT.	F.O.B. FACTORY EACH
5281 6921	Aero-Tote Tub	36" x 40" x 21-1/10"	22 lb.	\$293.95
5281 69251	Aero-Tote Tub w/Drain Plug	36" x 40" x 21-1/10"	22 lb.	314.95
5281 6922	Aero-Tote Lid	36-1/2" x 41" x 2"	13 lb.	167.95
5281 6923	Aero-Tote Pallet	32-7/10" x 37-1/5" x 9-1/2"	20 lb.	209.95

1-1/2-Inch Rubber Drain Plug for Stainless Vats



Metal Detectable 1-1/2-Inch Drain Plug for Stainless Vats



ITEM NO.	PRODUCT	EACH
3994 2606	1-1/2" Drain Plug	\$2.95

ITEM NO.	PRODUCT	EACH
3994 60081	1-1/2" Drain Plug	\$3.95

MACX™ Storage System

The durability and versatility of steel for the cost of plastic.

- Light-weight • Strong • Durable • Stackable



STORAGE BINS



10-high maximum stacking.

Standard MACX™ Bins

Light-weight, yet strong enough to hold 1,500 pounds of product.

- One-piece, injection molded construction.
- Made from high-density, food-grade structural plastic with a service life comparable to steel.
- Will not warp, dent, chip, splinter, rot or rust and are chemical and corrosion-resistant.
- Withstands temperatures from -32 °F to +165 °F.
- Completely sanitary: can be high-pressure washed and steam sterilized.
- Capacity: single bin, unstacked, static weight of 1,500 pounds.
- Drain and cap are available for liquid applications.
- Shipping weight: 89 pounds.
- Customizable: add casters, drain plugs, label holders, drop doors, attachable lids, custom colors and even emboss your company logo on the side. Call for more information.



MACX™ come standard with runners — easy for dumping or moving with a forklift.

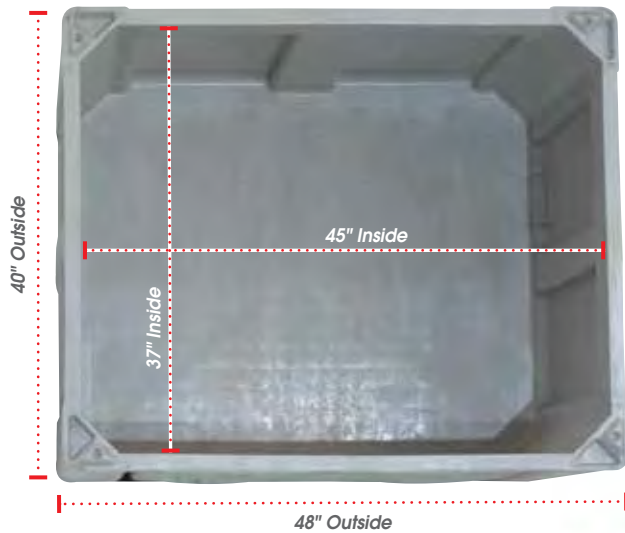

Smooth interior can easily be high-pressure washed and sterilized. Meets USDA/HACCP standards for food handling.



Optional drain and cap kit.



NOTE: MACX™ fits your equipment:
 48 inch x 40 inch standard pallet footprint.
 25.4 cubic feet; 190 US gallons.

ITEM NO.	PRODUCT	F.O.B. FACTORY EACH
3515 5732	Storage Bin, Solid, Gray	\$317.95
3515 5736	Storage Bin, Solid, White	338.95
3515 0052	Storage Bin, Vented, Gray	263.95
3515 5862	Stacking Lid, White	99.95
3515 5863	Drain and Cap Kit (For DIY Installation)	42.95

PRICES ARE SUBJECT TO CHANGE • MINIMUMS MAY APPLY • VISIT OUR WEBSITE FOR CURRENT PRICING.

Collapsible KitBins

All the benefits of the standard MACX™ bin, but with greater space efficiency.

- Engineered from maintenance-free, high-impact resistant HDPE structural foam for the highest strength-to-weight ratio.
- Removable walls provide easy access for loading and unloading.
- Withstands temperatures from -40° F to 140° F. Resists UV degradation.
- Solid or vented wall options. Panels are interchangeable.
- Stackable up to 6 units high.
- Four-way forklift entry.
- External Dimensions: 40 inches L x 48 inches W x 28 inches H.
Internal Dimensions: 36 inches L x 4 inches W x 23 inches H.
Pallet Dimensions: 48 inches x 40 inches.
Side Panels: 48 inches x 28 inches and 40 inches x 28 inches.
- Capacity: maximum weight load 1,320 pounds.
- Volume: 163 gallons/20 cubic feet.
- Replacement sides available.
- Shipping weight: 84 pounds.

Four disassembled containers fit into one bin, saving up to 75% trailer or storage space.



Posts securely lock sides together for a sturdy container even during transport.

All walls can be completely detached from the pallet, providing easy access for loading and unloading.



F.O.B. FACTORY EACH

ITEM NO.	PRODUCT	F.O.B. FACTORY EACH
3515 0100	Collapsible Bin, Solid Gray	\$399.95
3515 1100	Collapsible Bin, Vented Gray	399.95
3515 0010	Stacking Lid, White	89.95

ShuttleBin 330

Durable and fully-vented, this compact-folding bin is the single solution for retail transport, storage and display.

- Unique ten-point zipper latch system locks folding walls securely and ensures fast set-up and knock-down for increased productivity.
- Impact-grade plastic lasts longer, standing up to heavy day-to-day use.
- FDA-approved materials are certified safe for use with food products, eliminating many HACCP problems associated with wood bins.
- Splinter-resistant plastic delivers reduced maintenance costs, fewer injuries to workers and less damage to product and equipment.
- Hundreds of ventilation slots provide improved air flow and reduce heat absorption.
- Light-weight design (only 107 pounds with two drop-down doors) makes handling easy and reduces shipping costs.
- Nonporous surfaces won't absorb water or dehydrate your product like wood bins and they provide a constant tare weight throughout their use.
- Easy-to-sanitize, smooth surfaces keep cleaning costs to a minimum. A high-pressure wash removes most debris; a nonabrasive brush can dislodge any remaining items.
- External Dimensions: 40 inches L x 48 inches W x 33 inches H.
Internal Dimensions: 36-3/4 inches L x 44-3/4 inches W x 26-7/8 inches H.
- Load Capacity: 1,500 pounds.



Drop doors open and close for easy access



Fold-down collapsible design

Easily stackable

ITEM NO.	PRODUCT	EACH
H689 0240	ShuttleBin 330, Vented, Tan	\$321.95

Combo Cap Cover

Attach a combo cap cover over the top of your box to keep contents inside dust and particle free.

- 0.85 mil, clear boxed rolls.

NOTE: We recommend securing cap covers using liner bands, sold separately. SEE BELOW.

▶ 250 PER ROLL - 25 ROLLS PER PALLET.

ITEM NO.	PRODUCT	DIMENSIONS	ROLL	
			1-24	25+
H610 4513	Clear Cap Cover	54" x 44" x 36"	\$139.95	\$135.95



Liners come packaged on rolls inside a cardboard box.

Heavy-Duty Drum Liner

- 2.5 mil. • Color: clear.
- 38 inches x 60 inches.

ITEM NO.	PRODUCT
E539 3860	Drum Liner

▶ 125 LINERS PER ROLL

ROLL
\$187.95



Combo Poly Liners

- Increased differential slip allows for easy opening of liners every time.
- For use with cardboard combo bins. • 2 mil polyethylene.
- Plastic liner keeps food products from coming into contact with cardboard shipping containers.

▶ 25 LINERS PER ROLL

ITEM NO.	PRODUCT	ROLL
E539 0128	54" x 44" x 78"	\$95.95
E539 0115	54" x 44" x 87"	82.95
E539 0129	54" x 44" x 96"	120.95

NOTE: Other sizes and gauges of combo liners available. CALL FOR MORE INFORMATION.



▶ 50 PER BAG - 4 BAGS PER CASE.

ITEM NO.	PRODUCT	BAG	
		1-3	4+
B405 3073	Combo Liner Bands	\$69.95	\$68.95

Combo Liner Bands

- Use liner bands to secure combo liners and combo cap covers.
- Reusable bands are quickly applied or removed.



Cooler/Curb Ramp

- Ideal for carts, dollies and hand trucks being used in food service and cooler applications.
- Constructed of heavy-duty, light-weight aluminum with slip-resistant strips.
- Molded edging keeps truck from rolling off side of ramp.



Built-in stops keep the ramp from sliding and secures it firmly in place.



Handhold for easy carrying and hanging.

ITEM NO.	PRODUCT	DIMENSIONS	CAPACITY	EACH
3775 0172	Cooler Ramp	27" x 27"	.750 lb.	\$225.65

COMBO LINERS, CAPS, BANDS AND CURB RAMP

PRICES ARE SUBJECT TO CHANGE • MINIMUMS MAY APPLY • VISIT OUR WEBSITE FOR CURRENT PRICING.

Molded Plastic Freezer Spacer

- Unique design features holes throughout to decrease freezing times.
- Raised nubs along the edge keep boxes from sliding off.
- Shipping weight: 4-1/5 pounds, 2,000 pound capacity.
- Shipping weight: 4-2/5 pounds, 3,000 pound capacity.

▶ 500 PER PALLET.

ITEM NO.	PRODUCT	DIMENSIONS	CAPACITY	EACH	
				1-499	500+
2992 4049	Freezer Spacer . . .	40" x 48"	2,000 lb . . .	\$12.95	\$11.95

▶ 400 PER PALLET.

ITEM NO.	PRODUCT	DIMENSIONS	CAPACITY	EACH	
				1-399	400+
2992 3818	Anti-Slip Spacer. . .	40" x 48"	3,000 lb . . .	\$14.95	\$13.95

▶ 300 PER PALLET.

ITEM NO.	PRODUCT	DIMENSIONS	CAPACITY	EACH	
				1-299	300+
2992 4840	w/o Anti Slip.	40" x 48"	3,000 lb . . .	\$15.95	\$14.95



Chipboard Tier Sheets

- Use for shipping, palletizing and dividing stacked product.

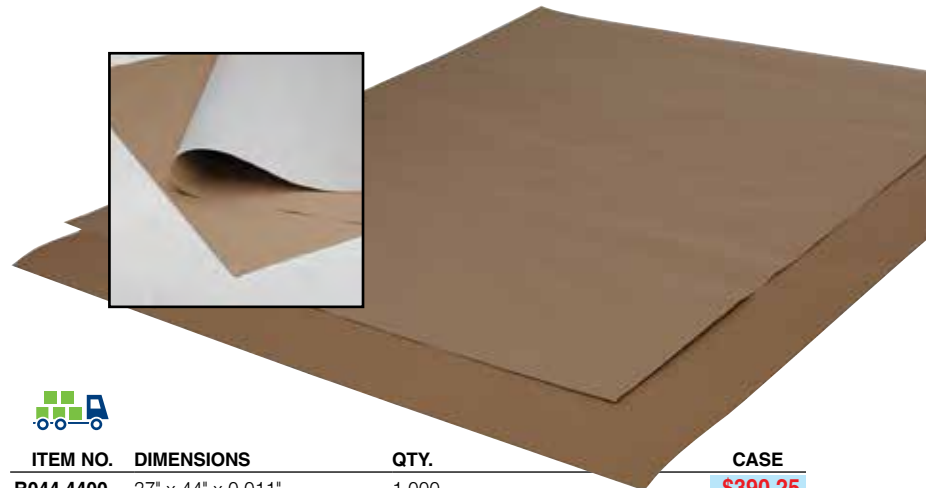

ITEM NO.	DIMENSIONS	QTY.	CASE
B044 4400	37" x 44" x 0.011"	1,000	\$390.25
B044 4725	40" x 47-1/4" x 0.012"	1,000	440.75

NEED ASSISTANCE?

Our experienced customer service representatives are available to answer your questions, find the products you are looking for, check product availability, as well as take your order.

800-456-5624



Slipsheets

Designed to supplement wood pallets in transportation and warehouse applications — reduce unloading time by 50%!



- Choose from: laminated, patterned top surface (A) or dimpled top surface keeps load from sliding (B).
- High-density polyethylene slipsheets are resistant to moisture, chemicals, heat and cold.
- Bottom surface allows the sheet to slide more easily for enhanced handling.
- Maintains strength and integrity even when wet.
- Manufactured from recycled plastic.
- 100% recyclable.
- Color: black.

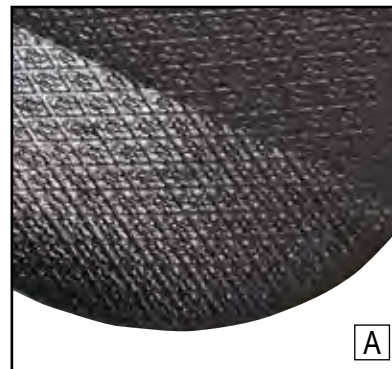

A



B

A. Patterned Top Surface

▶ 1,000 PER PALLET - SOLD BY PALLET ONLY.

ITEM NO.	DIMENSIONS	F.O.B. FACTORY	
		PALLET	EACH
1613 10251	54" x 40" x 0.025"	\$3,250.00	\$3.25
1613 42401	42" x 40" x 0.025"	3,250.00	3.25
1613 51251	51" x 43" x 0.025"	4,950.00	4.95
1613 54251	51" x 46" x 0.025"	4,350.00	4.35

B. EZ Grab Loadloc®

▶ 1,000 PER PALLET - SOLD BY PALLET ONLY.

ITEM NO.	DIMENSIONS	F.O.B. FACTORY	
		PALLET	EACH
1613 20181	40" x 54" x 0.025"	\$3,250.00	\$3.25
1613 61881	43" x 51" x 0.025"	4,350.00	4.35



Decade KitBin® Color Pallets

Perfect for food processing applications.

- Single-piece, high-density polyethylene construction stands up to heavy loads and continuous use.
- Easy-to-clean smooth surfaces have no splinters or wood chips.
- Up to 4,000 pounds dynamic load; up to 13,200 pounds static load.
- Available in gray, yellow, green or blue.
- Shipping weight: 41 pounds.
- Dimensions: 48 inches x 40 inches x 5-9/10 inches.

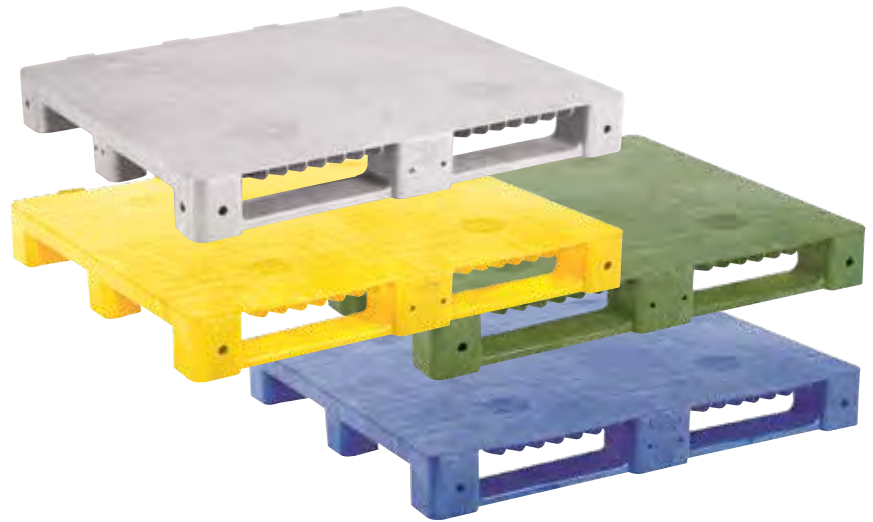

ITEM NO.	COLOR	F.O.B. FACTORY
3515 9201	Gray	EACH \$156.75
3515 9202	Yellow	
3515 9203	Green	
3515 9901	Blue	



Plastic Pallet Skids

Maintenance free alternative to wood pallets.

- Made of virgin polyethylene for longer life.
- Light-weight, rugged design.
- Built in drainage holes and serrated deck for non-slip performance.
- Easier to clean than traditional wooden pallets.
- Stackable with anti-slide grommets.
- Convenient 4-way fork entry.
- Ideal for food applications.
- Dimensions: 48 inches x 40 inches x 6 inches.
- Capacity: 2,200 pounds.



ITEM NO.	COLOR	F.O.B. FACTORY
H414 0003	Green	EACH \$193.75
H414 0004	Blue	
H414 0005	Orange	
H414 0006	Black	
H414 0007	Red	
H414 0008	Yellow	

Floor Static Capacity = 6,600 pounds
Fork Dynamic Capacity = 2,200 pounds
Weight = 38 pounds

Decade RACX® Pallets

- Fabricated of recycled HDPE plastics, these rackable pallets feature a picture frame bottom with runners on all four sides for stability.
- Ideal for use in warehouse racking systems, as well as stack loading, closed loop transport, floor storage and automated material handling applications.
- RACX® Pallets may be fitted with optional rubber grommets or lip to keep contents from slipping.
- Dimensions: 48 inches x 40 inches x 6-1/10 inches.
- Shipping weight: 35 pounds.



ITEM NO.	COLOR	F.O.B. FACTORY
3515 4856	Black	\$71.95
3515 4857	Blue	128.65
3515 0032	Red	128.65
3515 0033	Green	128.65



Floor Static Load Capacity = 25,000 pounds
Fork Dynamic Load Capacity = 5,000 pounds
Racking Load Capacity = 2,200 pounds

Open Foot Nestable Pallets

Open foot design allows for waste to easily exit the bottom of the pallet.

- Nestable/Stackable pallets are constructed of heavy-duty, single-piece molded polyethylene that meets USDA/FDA requirements.
- Catch points have been minimized for improved sanitation of the pallet.
- Four-way entry allows convenient lifting by forklift.
- Capacity up to 4,000 pound dynamic load; up to 30,000 pound static load.
- Grooved, slip-resistant decks are easy to clean.
- Rated for temperatures to -30 °F.
- 100% recyclable.

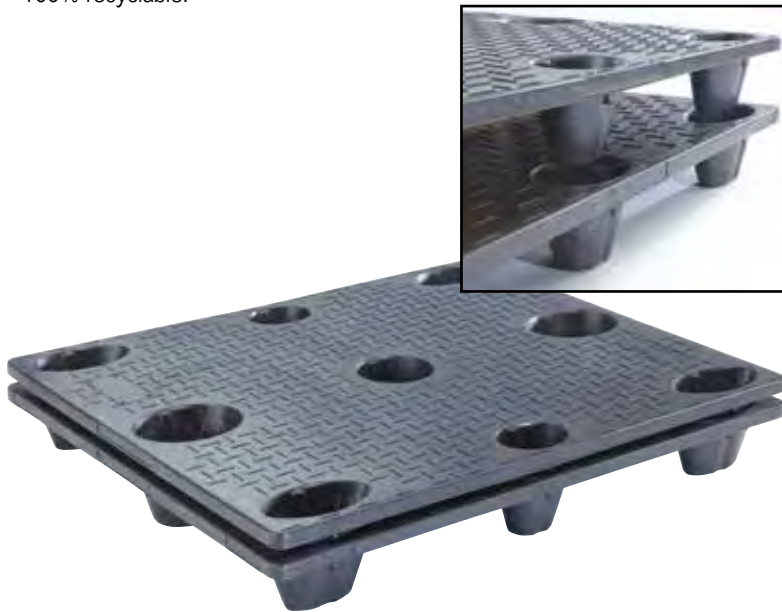

ITEM NO.	PRODUCT	DIMENSIONS	SHIPPING WT.	F.O.B. FACTORY EACH
A005 4840	I-Nest Pallet	48" x 40" x 6"	27 lb.	\$89.95

Pallet Truck, 5,500 Pound Capacity

- 3 mm thick adjustable connecting forks.
- Overload bypass.
- Rubber coated handle.
- 7-inch moldon polyurethane steering wheels.
3-inch moldon polyurethane load wheels.
- Entry and exit rollers.
- 210° steering.
- Some assembly required.



ITEM NO.	CAPACITY	DIMENSIONS	SHIPPING WT.	F.O.B. FACTORY EACH
7447 3448	5,500 lb	27" x 48"	194 lb.	\$656.95

Aluminum Pallet Mover

- For transporting 40-inch x 48-inch pallets.
- Ergonomic push handle for ease of movement.
- Floor lock on dolly securely keeps dolly in place.
- 6-inch x 2-inch polyurethane casters — 2 swivel with brakes and 2 rigid.



ITEM NO.	PRODUCT	F.O.B. FACTORY EACH
3775 0068	Aluminum Pallet Mover	\$908.25

Aluminum Tube Frame Pallet

Perfect for food processing applications.

- Sealed tube, all welded aluminum construction.
- Fireproof. Recyclable. Metal Detectable.
- Base: 3/4 inch x 3-3/8 inch tube construction.
- Risers: 2 inch x 2 inch x 0.2175 inch wall tubing.
- Load weights:
Static = 30,000 pounds
Dynamic = 5,000 pounds
Rackable = 5,000 pounds

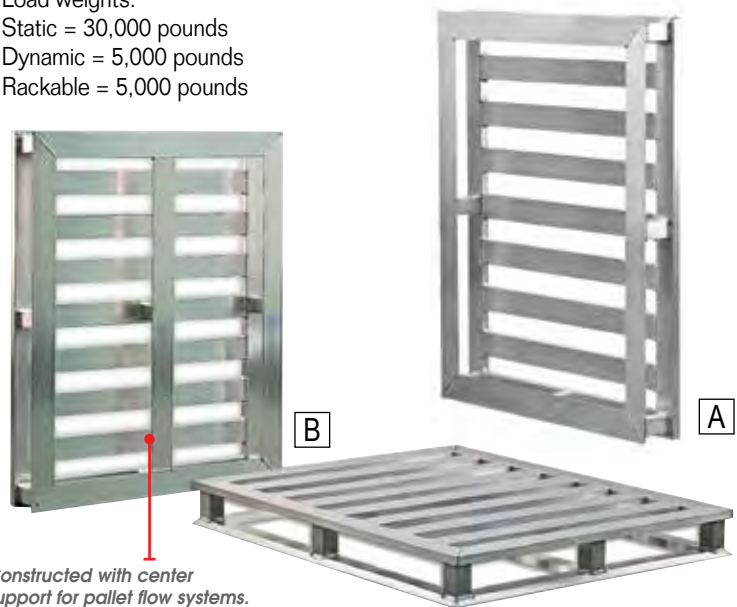

Constructed with center support for pallet flow systems.

ITEM NO.	DIMENSIONS	DYNAMIC CAPACITY	SHIPPING WT.	F.O.B. FACTORY EACH
3775 0013	A. 40" x 48" x 5-1/4"	5,000 lb	48 lb.	\$397.95
3775 0011	B. 40" x 48" x 5-1/4"	5,000 lb	51 lb.	411.55

PRICES ARE SUBJECT TO CHANGE • MINIMUMS MAY APPLY • VISIT OUR WEBSITE FOR CURRENT PRICING.

Solid Aluminum Wall Shelves

Ideal for maximizing storage space in your workplace or plant.

- 18-gauge shelves are constructed of 0.04 inch aluminum, 12-gauge shelves are constructed of 0.08 inch aluminum.
- Solid strip brackets give you the flexibility to install the shelving in two different ways.
- Shelves will not rust or corrode.

NOTE: Mounting hardware NOT INCLUDED.



Above the shelf where brackets can act as bookends.



Or with the brackets below the shelf.



ITEM NO.	SIZE	CAPACITY	GAUGE	EACH
3775 06751	12" x 24"	200 lb.	18.	\$65.05
3775 11251	12" x 36"	150 lb.	18.	96.55
3775 11261	12" x 48"	125 lb.	18.	106.05
3775 11271	12" x 60"	100 lb.	18.	120.65
3775 56341	18" x 24"	300 lb.	12.	125.95
3775 20931	18" x 36"	300 lb.	12.	133.35
3775 20941	18" x 48"	225 lb.	12.	171.05
3775 41361	18" x 60"	150 lb.	12.	192.05



A



B

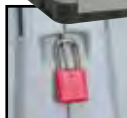

NOTE: Can be padlocked for added security. Padlocks sold separately.

For Locks ► SEE PAGE 278

Modular Storage Cabinets

Sturdy, molded plastic modular storage cabinets will not rust in wet environments.

- Simple snap-together assembly.
- Base cabinet knocks down to ship UPS.
- Resistant to moisture, dents and common chemicals.
- Interior shelves hold up to 180 pounds and adjust every 2 inches.
- Full cabinet features 4 shelves and the base cabinet has 2 shelves.
- Dimensions:
Base Cabinet (A): 36 inches x 18 inches x 36 inches.
Full Cabinet (B): 36 inches x 18 inches x 72 inches.



ITEM NO.	PRODUCT	SHIP WT.	EACH
1770 7085	A. Base Cabinet	28 lb.	\$199.95
1770 7083	B. Full Cabinet	69 lb.	299.95

Nixelite™ Solid Plastic Shelving

- Unit consists of 4 solid plastic shelves and 4 posts.
- Raised lip around edge of shelf prevents spills from overflowing.
- Each shelf has a load capacity of 300 pounds.



Posts constructed of chemical, acid, abrasion and corrosion-resistant Nixelon™ and allow shelves to be adjusted in 1 inch increments.



Level with just a twist of the wrist. Adjust loaded shelves with just an open-end wrench.

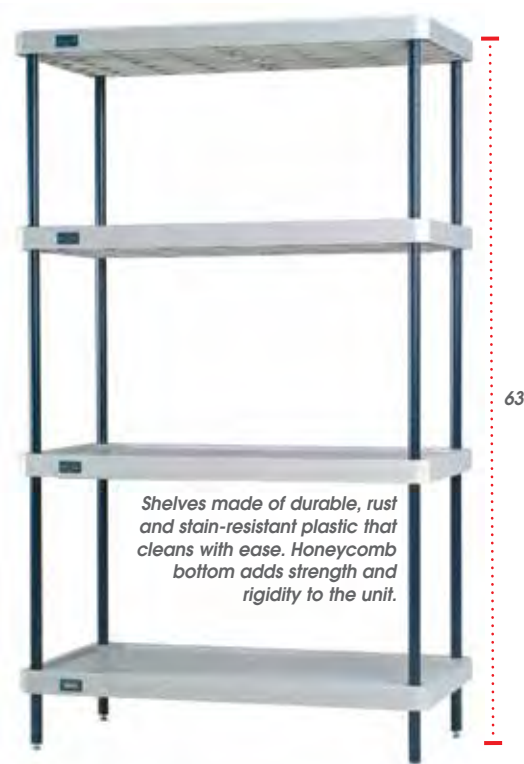

Shelves made of durable, rust and stain-resistant plastic that cleans with ease. Honeycomb bottom adds strength and rigidity to the unit.

ITEM NO.	PRODUCT	DIMENSIONS	EACH
5268 4486	Four Shelf Unit and Posts	48" x 24" x 63"	\$449.95
5268 0061	63" Replacement Posts		21.95

PRICES ARE SUBJECT TO CHANGE • MINIMUMS MAY APPLY • VISIT OUR WEBSITE FOR CURRENT PRICING.

Adjustable Aluminum Shelving

- Light-weight and durable, heavy-duty, all-welded aluminum tubing.
- Mix shelf styles on each unit to maximize storage.



CUSTOMIZE FOR YOUR APPLICATION – Just Order The Components You Need:

- 1. Uprights:** Start with four 68-inch uprights (see item# 3775 3916 BELOW).
- 2. Shelves:** Pick 4 or more shelves which fit your application. Choose from solid, close center or heavy-duty AS SHOWN BELOW.
- 3. Casters:** Add the optional caster kit for mobile shelf truck conversion. (Includes four, 5-inch black polyolefin wheels with 1 inch swivel, stem-type casters, each with locking brake.)



Scan this QR code with your mobile device to view a video of the features of adjustable aluminum shelving.



Shelves are easily assembled with 5/16-inch Allen wrench.



The mobile shelf unit shown here uses solid 20-inch x 36-inch shelves. (Item# 3775 4403)



Caster Kit, Optional For this shelving unit ONLY.



ITEM NO.	PRODUCT	EACH
0844 39005	Four Caster Kit.	\$85.95

Close Center Shelves

- Maximum strength and air circulation.
- 1-inch x 1-1/2-inch T-bars are welded on 2 inch centers.
- Durable 1-1/2-inch x 1-3/4-inch frame.
- Load capacity per shelf: 1,000 pounds.
- Unit load capacity with caster conversion: 700 pounds.



F.O.B. FACTORY

ITEM NO.	PRODUCT	SHIP WT.	EACH
3775 4162	20" x 36"	9 lb.	\$118.65
3775 4163	20" x 48"	12 lb.	136.45
3775 4164	20" x 60"	14 lb.	147.95
3775 4165	20" x 72"	17 lb.	178.45
3775 3916	Upright, 68"	4 lb.	34.65

Economy Solid Shelves

- Solid 0.040-inch aluminum sheet.
- Double-thick, raised marine edge.
- Contains spills and makes clean-up easier.
- Load capacity per shelf: 400 pounds.
- Unit load capacity with caster conversion: 700 pounds.



F.O.B. FACTORY

ITEM NO.	PRODUCT	SHIP WT.	EACH
3775 4403	20" x 36"	5 lb.	\$128.05
3775 4404	20" x 48"	6 lb.	133.35
3775 4405	20" x 60"	7 lb.	136.45
3775 4406	20" x 72"	8 lb.	143.75
3775 3916	Upright, 68"	4 lb.	34.65

Heavy-Duty Shelves

- Ideal for large, bulky items that need superior air circulation.
- Load capacity per shelf: 1,500 pounds.
- Unit load capacity with caster conversion: 700 pounds.



F.O.B. FACTORY

ITEM NO.	PRODUCT	SHIP WT.	EACH
3775 3912	20" x 36"	8 lb.	\$102.85
3775 3913	20" x 48"	10 lb.	114.35
3775 3914	20" x 60"	12 lb.	125.95
3775 3915	20" x 72"	14 lb.	147.95
3775 3916	Upright, 68"	4 lb.	34.65

Heavy-Duty Wire Shelving

Rustproof, green epoxy coating is applied over a zinc-chromate finish and will stand up to years of harsh conditions.



Shelves feature an open heavy-gauge wire design allowing greater air circulation and improving visibility of stored items.

▶ SEE PAGE 248
Food Containers Sold Separately.

▶ SEE PAGE 206
Food Boxes Sold Separately.

Holds up to 2,400 pounds!
Recommended weight distribution: 800 pounds max per lower shelves and 400 pounds max per upper shelves.
Load capacity with casters is 500 pounds total.



EACH

ITEM NO.	PRODUCT	1-3	4+
3419 49681	18" x 24" Shelves	\$29.95	\$28.95
3419 49691	18" x 36" Shelves	34.95	33.95
3419 49701	18" x 48" Shelves	42.95	41.95
3419 49711	18" x 60" Shelves	56.95	55.95
3419 49721	18" x 72" Shelves	64.95	63.95
3419 49731	24" x 36" Shelves	45.95	44.95
3419 49741	24" x 48" Shelves	57.95	56.95
3419 49751	24" x 60" Shelves	69.95	68.95
3419 49761	24" x 72" Shelves	77.95	76.95
3419 49791	36" Post (comes as 1 piece)	12.95	---
3419 49781	72" Post (comes as 2 pieces)	18.95	---
3419 49771	"S" Clip	3.95	---
3419 4100	Replacement Shelf Clips, 4/Bag	3.95	---
4804 0000	Caster Kit, 4 Casters	79.95	78.95

THE SECRET Behind the Strength



3-wire truss all-welded design makes it a dozen times stronger than a solid steel truss of the same weight.

EASY, NO-TOOLS ASSEMBLY!



- Just screw the post together then snap the sleeve onto the desired indexing groove and drop the shelf's collar over it.



- Posts are numbered for easy assembly.



- Shelves can be adjusted at 1 inch increments along the entire length of the post.

- Tie multiple units together with our "S" clips for increased rigidity and storage space.

- Combine different depth shelves to jog around wall protrusions, run-around corners, etc.



LEVELING IS A BREEZE!



- Level with just a twist of the wrist.

- Adjust loaded shelves with an open-end wrench.

- For mobility, replace the levelers with a caster kit.

- Leveling bolt: 3/8" x 16 tpi.

CASTER KIT

Move your shelving easily by replacing levelers with casters. Each caster kit contains four, 5-inch casters (2 with locks and 2 without locks) and four easy-to-install adapter sleeves that better reinforce the legs of the shelving structure and allow the casters to fit securely over them. These unique sleeves keep the legs from bending on loads totaling **up to 500 pounds**.

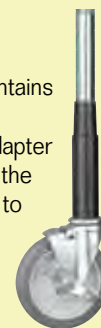

BUILD YOUR OWN 18-inch x 24-inch Four Shelf Unit ONLY \$191.60

ITEM NO.	QTY.	PRODUCT	
3419 49681	4	18" x 24" Shelves	\$115.80
3419 49781	4	72" Vertical Posts	75.80
Add a caster kit (4804 0000) for mobility + \$79.95			\$191.60

CALL 800-456-5624 for more information and to place your order

Molded Plastic Wheels

Non-marking, white polyolefin wheels. Recommended for all applications where strict sanitation is required. Ideal for food plants and wet environments.

- Steam clean, detergent proof.
- Acid-resistant.
- Will not mark floors.
- Never requires lubrication.
- Very durable, quiet rolling.
- Fits most popular caster frames.
- Withstand temperatures from -30 °F to +250 °F.



Standard White Polyolefin Wheels using a 1/2-Inch Spanner

ITEM NO.	A. WHEEL DIAMETER	B. TREAD WIDTH	C. BORE	D. HUB	LOAD CAPACITY	EACH
0844 2213	3"	1-3/8"	1/2"	1-1/2"	240 lb.	\$6.25
0844 4521	4"	1-3/8"	1/2"	1-1/2"	265 lb.	6.25
0844 2221	5"	1-1/4"	1/2"	1-1/2"	265 lb.	6.45
0844 2691	5"	1-1/2"	1/2"	1-5/8"	500 lb.	8.50
0844 2692	6"	1-1/2"	1/2"	1-5/8"	600 lb.	10.40
0844 2227	1/2" Stainless Steel Spanner Bushing For 3/8" Axle					8.20

Standard White Polyolefin Wheels using a 3/4-Inch Spanner

ITEM NO.	A. WHEEL DIAMETER	B. TREAD WIDTH	C. BORE	D. HUB	LOAD CAPACITY	EACH
0844 2223	5"	2"	3/4"	2-3/16"	650 lb.	\$9.30
0844 2225	6"	2"	3/4"	2-3/16"	700 lb.	9.75
0844 2226	8"	2"	3/4"	2-3/16"	900 lb.	10.95
0844 2229	3/4" Stainless Steel Spanner Bushing For 1/2" Axle					11.95

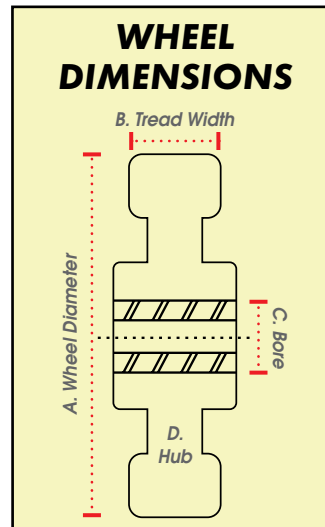

NEED ASSISTANCE?

Our experienced customer service representatives are available to help you today!

800-456-5624

Stainless Steel Spanner Bushings

- (A) 1/2 inch OD x 3/8 inch ID.
- (B) 3/4 inch OD x 1/2 inch ID.

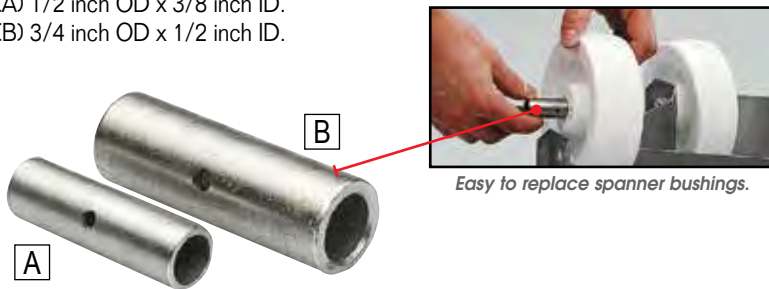

ITEM NO.	PRODUCT	EACH
0844 2227	A. 1/2" x 3/8"	\$8.20
0844 2229	B. 3/4" x 1/2"	11.95

Greaseable Zerk Axle and Delrin Spanner Bushing

- 3/4 inch OD x 1/2 inch ID x 2-5/16 inches long.
- Stainless axle is 3 inches long.



ITEM NO.	PRODUCT	EACH
0844 21331	Greaseable Axle w/Bushing	\$12.95

NOTE: Recommended when you replace wheels in order to extend wheel life in harsh environments.

Posi-Lock Brakes

Easy to install on your existing wheels and casters.

- Posi-Lock brakes fit all 1-3/8 inch to 1-1/2 inch tread width wheels using a 3/8 inch axle.

NOTE: Not to be used with the Economy Plated Casters shown on facing page.

ITEM NO.	PRODUCT	EACH
0844 0003	For 3" Wheel	\$10.95
0844 0004	For 4" Wheel	10.40
0844 0005	For 5" Wheel	10.95
0844 0006	For 6" Wheel	10.95



Economy Plated Casters

Zinc plated steel frames.

- Heavy-duty king pins.
- All swivels have double bearing raceways.
- Type I wheels for medium-duty applications.
- Type II wheels for heaviest loads and constant swiveling.
- Delrin bushing.

Type I shown without greaseable axle.



NOTE: See diagram to choose caster top plate needed.



Type I For Medium-Duty Applications, without Greaseable Axle

Rigid-Type I Top Plate

ITEM NO.	A. WHEEL DIAMETER	B. TREAD WIDTH	HEIGHT	LOAD CAPACITY	EACH
0844 2380	3"	1-3/8"	4-1/8"	240 lb.	\$10.95
0844 2382	4"	1-1/4"	5-1/8"	300 lb.	10.95
0844 2384	5"	1-1/4"	6-1/4"	300 lb.	13.95

Swivel-Type I Top Plate

ITEM NO.	A. WHEEL DIAMETER	B. TREAD WIDTH	HEIGHT	LOAD CAPACITY	EACH
0844 2379	3"	1-3/8"	4-1/8"	240 lb.	\$14.95
0844 2381	4"	1-1/4"	5-1/8"	300 lb.	12.95
0844 2383	5"	1-1/4"	6-1/4"	300 lb.	17.95

Type II For Heavy-Duty Applications, with Greaseable Axle

Rigid-Type II Top Plate

ITEM NO.	A. WHEEL DIAMETER	B. TREAD WIDTH	HEIGHT	LOAD CAPACITY	EACH
0844 2386	5"	2"	6-1/2"	650 lb.	\$16.95
0844 2388	6"	2"	7-1/2"	700 lb.	17.95
0844 2990	8"	2"	9-1/2"	900 lb.	19.95

Swivel-Type II Top Plate

ITEM NO.	A. WHEEL DIAMETER	B. TREAD WIDTH	HEIGHT	LOAD CAPACITY	EACH
0844 2385	5"	2"	6-1/2"	650 lb.	\$21.95
0844 2387	6"	2"	7-1/2"	700 lb.	22.95
0844 2991	8"	2"	9-1/2"	900 lb.	27.95

STAINLESS STEEL TYPE II CASTER

Dual ball bearing raceways are stainless to withstand harsh environments.

Upper and lower raceways are sealed with neoprene rubber to keep lubricant in and contaminants out.

Formed stainless caster forks are welded to lower raceway for maximum service.

Large king pin for added strength. Protects against impact and abuse.

Replaceable zerk fitting makes routine maintenance easy.

Stainless spanners do not require lubrication.

CASTER TOP PLATE ILLUSTRATIONS

TYPE I TOP PLATE
Slotted Bolt Holes
1-3/4" x 2-7/8"
2-3/8"

TYPE II TOP PLATE
Slotted Bolt Holes
2-5/8" x 3-5/8"
4"

3-5/8"

Stainless Steel Casters

Resists rust and corrosion.

- Casters with poly wheels designed specifically to withstand constant use in harsh, corrosive wet environments.
- Whatever your application, we have the caster and wheel to fit it – in stock and ready to ship!
- Call today to discuss your specific corrosive applications.



Zerk fitting makes routine maintenance easy.

NOTE: See diagram to choose caster top plate needed.



Type I For Medium-Duty Applications, Without Greaseable Axle

Rigid-Type I Top Plate

ITEM NO.	A. WHEEL DIAMETER	B. TREAD WIDTH	HEIGHT	LOAD CAPACITY	EACH
0844 2666	4"	1-3/8"	5-1/16"	300 lb.	\$28.95
0844 2670	5"	1-3/8"	6-1/8"	300 lb.	30.95

Swivel-Type I Top Plate

ITEM NO.	A. WHEEL DIAMETER	B. TREAD WIDTH	HEIGHT	LOAD CAPACITY	EACH
0844 2665	4"	1-3/8"	5-1/16"	300 lb.	\$48.95
0844 2669	5"	1-3/8"	6-1/8"	300 lb.	51.95

Type II For Heavy-Duty Applications, with Greaseable Axle

Rigid-Type II Top Plate

ITEM NO.	A. WHEEL DIAMETER	B. TREAD WIDTH	HEIGHT	LOAD CAPACITY	EACH
0844 2673	5"	1-1/2"	6-1/8"	300 lb.	\$37.95
0844 2677	6"	1-1/2"	7-3/16"	300 lb.	45.95
0844 3489	6"	2"	7-1/2"	700 lb.	55.95
0844 3491	8"	2"	9-1/2"	850 lb.	65.95

Swivel-Type II Top Plate

ITEM NO.	A. WHEEL DIAMETER	B. TREAD WIDTH	HEIGHT	LOAD CAPACITY	EACH
0844 2672	5"	1-1/2"	6-1/8"	300 lb.	\$53.95
0844 2676	6"	1-1/2"	7-3/16"	300 lb.	69.95
0844 3488	6"	2"	7-1/2"	700 lb.	80.95
0844 3490	8"	2"	9-1/2"	850 lb.	92.95

Heavy-Duty Plate Style Casters

- Swivel Casters — Formed legs are continuously welded, 1/4-inch steel top plate is cold forged and heat treated to relieve stress and add strength.
- Main Load Bearing — Fully hardened ball bearings in a hardened raceway.
- Thrust Bearing — Large diameter hardened ball bearings roll freely in a hardened raceway.
- 1/2-inch axle diameter.
- 3/8-inch attached bolt.
- Lube Fittings — Provided for both swivel and wheel bearings (for rubber wheels only).
- King Pin coined and stress relieved - Holds raceways precisely in alignment.
- Finish - Corrosion-resistant zinc.

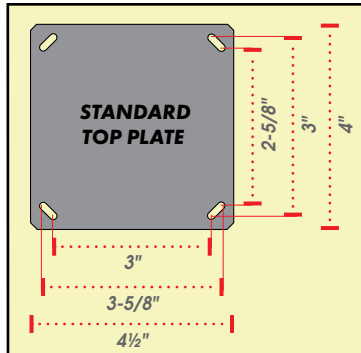
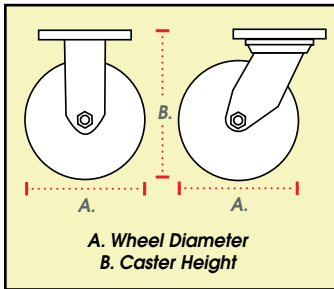

Mold-On Rubber Wheels

ITEM NO.	PRODUCT	A. WHEEL DIA.	TREAD WIDTH	B. HEIGHT	CAPACITY	F.O.B. FACTORY EACH
0844 0140	Swivel	5"	2"	6-1/2"	400 lb.	\$25.95
0844 0141	Rigid	5"	2"	6-1/2"	400 lb.	21.95
0844 0142	Swivel	6"	2"	7-1/2"	410 lb.	24.95
0844 0143	Rigid	6"	2"	7-1/2"	410 lb.	23.95
0844 0144	Swivel	8"	2"	9-1/2"	500 lb.	27.95
0844 0145	Rigid	8"	2"	9-1/2"	500 lb.	25.95

Polyurethane on Polyolefin Wheels

ITEM NO.	PRODUCT	A. WHEEL DIA.	TREAD WIDTH	B. HEIGHT	CAPACITY	F.O.B. FACTORY EACH
0844 0154	Swivel	4"	2"	5-5/8"	700 lb.	\$25.95
0844 0155	Rigid	4"	2"	5-5/8"	700 lb.	23.95
0844 0156	Swivel	5"	2"	6-1/2"	750 lb.	26.95
0844 0157	Rigid	5"	2"	6-1/2"	750 lb.	23.95
0844 0158	Swivel	6"	2"	7-1/2"	900 lb.	28.95
0844 0159	Rigid	6"	2"	7-1/2"	900 lb.	25.95
0844 0160	Swivel	8"	2"	9-1/2"	900 lb.	31.95
0844 0161	Rigid	8"	2"	9-1/2"	900 lb.	28.95

Reinforced Thermoplastic Wheels

ITEM NO.	PRODUCT	A. WHEEL DIA.	TREAD WIDTH	B. HEIGHT	CAPACITY	F.O.B. FACTORY EACH
0844 0146	Swivel	4"	2"	5-5/8"	800 lb.	\$22.95
0844 0147	Rigid	4"	2"	5-5/8"	800 lb.	19.95
0844 0148	Swivel	5"	2"	6-1/2"	900 lb.	22.95
0844 0149	Rigid	5"	2"	6-1/2"	900 lb.	21.95
0844 0150	Swivel	6"	2"	7-1/2"	900 lb.	26.95
0844 0151	Rigid	6"	2"	7-1/2"	900 lb.	23.95
0844 0152	Swivel	8"	2"	9-1/2"	1,000 lb.	27.95
0844 0153	Rigid	8"	2"	9-1/2"	1,000 lb.	24.95

Mold-on Rubber Wheels

- Applications: warehouse environments where floor protection and noise reduction are required.
- Soft rubber tread rolls over floor joints and small obstructions quietly and smoothly.
- Composition: cushioned rubber tread permanently vulcanized to cast iron cores.
- Recommended for quiet movement with medium to heavy loads or where cushioning load is required.
- Temperature range: -30 °F to 160 °F. • Zerk fitting in hub.



ITEM NO.	WHEEL DIAMETER	TREAD WIDTH	HUB	AXLE DIAMETER	CAPACITY	F.O.B. FACTORY EACH
0844 0120	5"	2"	2-7/16"	3/4"	400 lb.	\$15.95
0844 0121	6"	2"	2-7/16"	3/4"	410 lb.	16.95
0844 0122	8"	2"	2-7/16"	3/4"	500 lb.	17.95
0844 0123	10"	2-1/2"	2-3/4"	1"	790 lb.	39.95
0844 0124	10"	3"	3"	1"	1,000 lb.	45.95
0844 0125	12"	2-1/2"	2-1/2"	1-1/4"	900 lb.	51.95
0844 0126	14"	3"	3"	1-1/4"	1,200 lb.	83.95

Reinforced Thermoplastic Wheels

- Applications: suitable for food processing environments.
- High-resistance to shock and impact loads.
- Resists caustics and chemicals.
- Composed of reinforced thermoplastic.
- Temperature range: -20 °F to 250 °F.
- Low rolling resistance. • Will not absorb water.



ITEM NO.	WHEEL DIAMETER	TREAD WIDTH	HUB	AXLE DIAMETER	CAPACITY	F.O.B. FACTORY EACH
0844 0135	4"	1-1/2"	1-5/8"	1/2**	700 lb.	\$10.25
0844 0136	4"	2"	2-7/16"	1/2**	800 lb.	11.95
0844 0137	5"	2"	2-7/16"	1/2**	1,000 lb.	13.95
0844 0138	6"	2"	2-7/16"	1/2**	1,200 lb.	14.95
0844 0139	8"	2"	2-7/16"	1/2**	1,400 lb.	14.95

* Included reducer makes axle diameter 1/2".

Polyurethane on Polyolefin Wheels

- Applications: alternative to polyurethane on steel or aluminum cores, yet offers the same long wearing tread characteristics.
- Well suited for wet environments with delrin bearings.
- Resists chemicals, caustics, acids and oils.
- Composed of polyurethane tread mechanically and chemically bonded to a polyolefin core.
- Quiet rolling yet good load capacity.
- Temperature range: -40 °F to 180 °F.
- Should not be used where possibility for shock or high-impact exists.



ITEM NO.	WHEEL DIAMETER	TREAD WIDTH	HUB	AXLE DIAMETER	CAPACITY	F.O.B. FACTORY EACH
0844 0127	3"	1-1/4"	1-9/16"	3/8"	400 lb.	\$9.35
0844 0128	3-1/2"	1-1/4"	1-9/16"	3/8"	410 lb.	10.30
0844 0129	4"	1-1/4"	1-9/16"	3/8"	500 lb.	11.95
0844 0130	4"	2"	2-7/16"	1/2"	790 lb.	14.95
0844 0131	5"	1-1/4"	1-9/16"	3/8"	1,000 lb.	10.95
0844 0132	5"	2"	2-7/16"	1/2"	900 lb.	14.95
0844 0133	6"	2"	2-7/16"	1/2"	900 lb.	15.95
0844 0134	8"	2"	2-7/16"	1/2"	1,000 lb.	19.95

Polyurethane 6-Inch Wheels

Lasts 10 times longer than standard wheels.

- Non marking. • Quiet rolling with ball bearings.
- Temperature range -50 °F to 180 °F.
- Requires minimum maintenance when installed with stainless bushings and zerk axle.



► SEE PAGE 230
For Bushings and Axles

ITEM NO.	WHEEL DIAMETER	TREAD WIDTH	HUB	CAPACITY	EACH
0844 16201	6"	2"	2-3/8"	1,000 lb.	\$36.95

Stem Type Casters

- Load Bearing — two full independent rows of hardened and polished ball bearings.
- Choose between Rubber Wheels or TPR (Thermo Plastic Rubber) Wheels for heavier load capacities.
- Stamped and formed construction. • Finish — corrosion-resistant zinc.

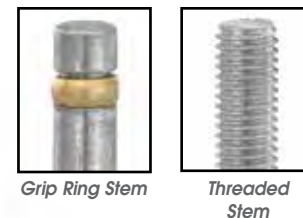

Threaded Stem

ITEM NO.	PRODUCT	STEM LENGTH	A. WHEEL DIAMETER	TREAD WIDTH	B. HEIGHT	CAPACITY	EACH
0844 0162	Rubber Wheel	1-1/8"	3"	15/16"	2-1/2"	110 lb.	\$8.75
0844 0163	TPR Wheel	1-1/8"	3"	15/16"	2-1/2"	110 lb.	8.95
0844 0164	TPR Wheel	1-1/2"	4"	15/16"	4-11/16"	115 lb.	11.95
0844 0165	TPR Wheel	1-1/2"	5"	15/16"	5-23/32"	135 lb.	11.95

Grip Ring Stem

ITEM NO.	PRODUCT	STEM LENGTH	A. WHEEL DIAMETER	TREAD WIDTH	B. HEIGHT	CAPACITY	EACH
0844 0166	TPR Wheel	1-3/8"	4"	15/16"	4-11/16"	115 lb.	\$11.95
0844 0167	TPR Wheel	1-3/8"	5"	15/16"	5-23/32"	125 lb.	13.95
0844 4201	TPR Wheel	2-1/32"	5"	15/16"	5-23/32"	135 lb.	13.95
0844 4202	TPR Wheel	2-1/32" w/Brake	5"	15/16"	5-23/32"	135 lb.	15.95

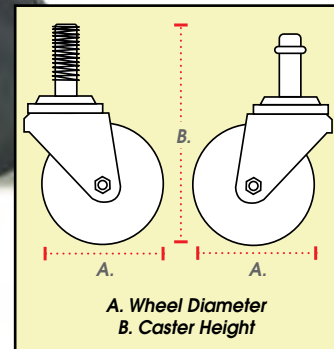

Replacement Dolly Casters

Grip Ring Style Casters

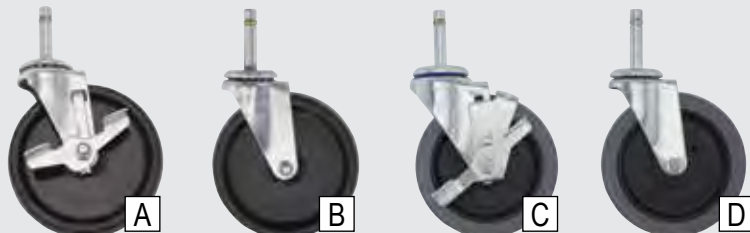
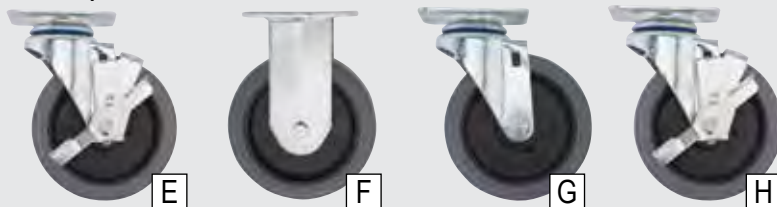

Plate Style Casters



Standard-Duty 5-Inch Casters

Caster capacity: 135 pounds per wheel

ITEM NO.	PRODUCT	EACH
0844 4202	A. Grip Ring Stem, Swivel, With Brake	\$15.95
0844 4201	B. Grip Ring Stem, Swivel, No Brake	13.95

Heavy-Duty 5-Inch Casters

Caster capacity: 250 pounds per wheel

ITEM NO.	PRODUCT	EACH
0844 22201	C. Grip Ring Stem, Swivel, With Brake	\$19.95
0844 22191	D. Grip Ring Stem, Swivel, No Brake	16.95
0844 22171	E. Plate Swivel, With Brake	24.95
0844 22181	F. Plate Rigid, No Brake	15.95
0844 22161	G. Plate Swivel, No Brake (NOT for Freezer Usage)	19.95
0844 05181	Plate Swivel, No Brake (For Freezer Usage)	15.95
0844 22011	H. Plate Swivel, With Brake (For Freezer Usage)	26.95

For Compatible Dollies > SEE PAGES 193-197

Sockets for Round and Square Tubing

Patented reinforced thermoplastic design.

- Unlike plastic or steel, sockets will not loosen or wear.
- Use with Grip-Ring style stems — fits 7/16 inch stems up to 1-1/2 inches long.

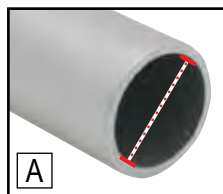

Round tube inside dimension.

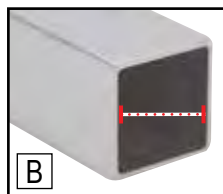

Square tube inside dimension.



NOTE: NOT designed for use with D-shaped tubing.

A. Socket for Round Tubing

ITEM NO.	SOCKET NUMBER	INSIDE TUBE DIMENSIONS	EACH
0844 0168	RD1	0.777"	\$4.35
0844 0169	RD2	0.872"	
0844 0170	RD3	0.844"	
0844 0171	RD9	0.902"	
0844 0172	RD4	1.072"	
0844 0173	RD5	1.120"	
0844 0174	RD6	1.310"	
0844 0175	RD7	1.495"	

B. Socket for Square Tubing

ITEM NO.	SOCKET NUMBER	INSIDE TUBE DIMENSIONS	EACH
0844 0176	SQ1	0.620"	\$4.35
0844 0177	SQ2	0.652"	
0844 0178	SQ3	0.870"	
0844 0179	SQ4	0.902"	
0844 0180	SQ5	1.010"	
0844 0181	SQ6	1.120"	
0844 0182	SQ7	1.140"	
0844 0183	SQ8	1.152"	
0844 0185	SQ10	1.402"	

Stainless V-Edge Dump Buggies

Smooth seams make it easy to wash.

- Choose from solid 1 inch rolled or flat bar rim welded v-edge.
- Heavy-Duty T-304 stainless steel construction with smooth seams.
- Standard stainless steel lifting lugs and closed-end drip guards meet USDA standards.
- Equipped with 2-inch x 6-inch white poly wheels, replaceable Delrin spanner bushings with greaseable zerk axles.
- Interior Dimensions:
400 pounds — 21 inches L x 24 inches W x 20 inches H.
600 pounds — 21 inches L x 24 inches W x 30 inches H.



Optional heavy-duty plastic lid.



600-pound buggy available with handle.



NOTE: Heavy-duty plastic lid sold separately. SEE BELOW.



Flat Bar welded rim.



Rolled and welded rim.

Reinforced bottom that cross-ties the four wheels together for added strength and durability.



V-Edge



Greaseable/replaceable zerk axle.



Replaceable wheels and bushings.

Full width stainless steel drip guard.



ITEM NO.	PRODUCT	EDGE	CAPACITY	SHIP WT.	EACH
2990 4528	V-Edge Buggy	Rolled Rim	400 lb.	77 lb.	CALL FOR PRICING
2990 4529	V-Edge Buggy	Rolled Rim	600 lb.	97 lb.	
2990 4251	V-Edge Buggy w/Handle	Rolled Rim	600 lb.	97 lb.	
2990 1150	V-Edge Buggy	Flat Bar Rim	600 lb.	97 lb.	
3502 98241	Optional V-Edge Buggy Lid				\$36.95
0844 2225	Replacement Wheel				9.75
0844 2229	Replacement Bushing (Stainless Steel)				11.95
0844 20311	Replacement Zerk Axle				11.95

EZ-Way Knock-Down BuggyWash™

- Heavy-duty welded, stainless steel.
- Helps to reduce back strain and injury.
- Stainless steel construction won't rust.
- Use with lifting lugs up to 28-1/2 inches from the floor.
- Places the buggy at the optimal angle to wash and drain.



1

Place buggy in washer using lifting lugs.



2

Tilt washer and buggy back.

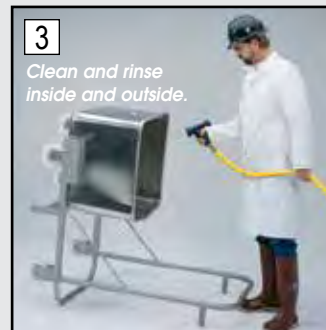

3

Clean and rinse inside and outside.

This stainless steel one-man buggy washer makes buggy washing as easy as 1 - 2 - 3!



ITEM NO.	PRODUCT	DIMENSIONS	SHIP WT.	EACH
2990 0450	Buggy Wash	29" W x 54" H.	50 lb.	CALL FOR PRICING



Stainless Steel Pails

Heavy, 16-gauge type 304 stainless-steel polished finish inside and out.

- Welded construction, no crevices to collect dirt or bacteria.
- Smooth top edge.

Stainless Steel Pail

- One piece chime, sealed around the bottom.



ITEM NO.	SIZE	WEIGHT	EACH
3013 20131	13 qt. Pail	4-1/2 lb	\$134.75
3013 20161	16 qt. Pail	5-1/2 lb	147.65

Stainless Steel Pail with Tilt Handle

- Ergonomic handle positioned for easy pouring.



ITEM NO.	SIZE	WEIGHT	EACH
3013 20141	13 qt. with Tilt Handle	4-1/2 lb	\$147.65
3013 20181	16 qt. with Tilt Handle	5-1/2 lb	165.75

Stainless Steel, 55-Gallon Process Drum

- Completely welded, open rim adds strength.
- ID: 21-1/2 inch dia. x 35-3/4 inches H.
- OD: 23-1/2 inch dia. x 36-1/2 inches H.
- Weight: 40 pounds.

NOTE: Stainless steel lid sold separately. SEE BELOW.



ITEM NO.	PRODUCT	EACH
2990 1389	Drum	CALL FOR PRICING
2990 1390	Lid	CALL FOR PRICING

▶ SEE PAGE 254

FOR COLOR-CODED POLY PAILS

Stainless Steel Elevated Truck

Ergonomic "Back Saver" design for easy loading/unloading.

- Ergonomic working height.
- Solid stainless steel construction with smooth seams.
- Fully welded inside and out.
- Heavy-duty 14-gauge, type 304 stainless steel.
- 5-inch x 2-inch black poly wheels: 2 rigid - 2 swivel.
- Drain and cap for easy cleaning.

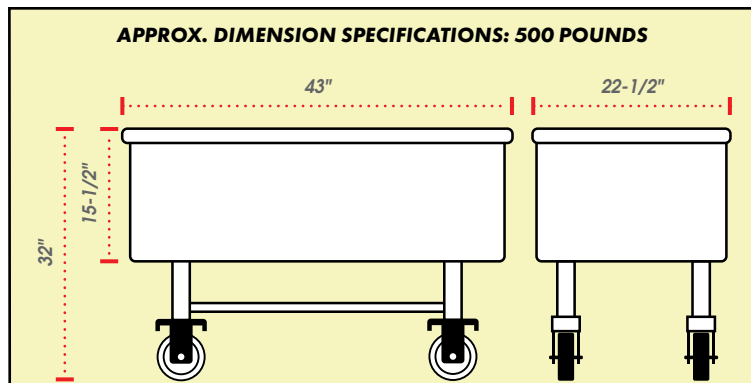

ITEM NO.	PRODUCT	SHIPPING WT.	EACH
2990 2816	500 lb Capacity SS Elevated Truck	94 lb.	CALL FOR PRICING

Stainless Steel Sausage Truck

- Heavy-duty 14-gauge, type 304 stainless steel truck body is continuously welded for added strength and sanitation.
- A solid rod reinforces the exclusive welded rim.
- Large center load wheels allow truck to turn in tight spaces.
- Reinforced understructure supports casters easily.

APPROX. DIMENSION SPECIFICATIONS

	A.	B.	C.	D.
500 Pounds	16"	23-1/2"	43"	20-3/4"
800 Pounds	19"	26-3/4"	43-3/4"	30"
1,100 Pounds	19"	28"	58"	30-3/4"

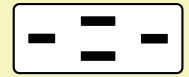

Standard wheel configuration for 500- and 800-pound trucks — four rigid.

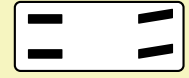

Standard wheel configuration for 1,100 pound trucks — two rigid and two swivel.



A stainless chain secures the threaded cap for 1-1/2" pipe drain.

ITEM NO.	PRODUCT	SHIPPING WT.	EACH
2990 4988	500 lb Capacity SS Sausage Truck	110 lb.	CALL FOR PRICING
2990 4990	800 lb Capacity SS Sausage Truck	104 lb.	CALL FOR PRICING
2990 5388	1,100 lb Capacity SS Sausage Truck	144 lb.	CALL FOR PRICING

EasyRol Sausage Truck

14-inch center load wheel for easier maneuvering over uneven surfaces, even with heavy loads.

- Solid stainless steel construction with smooth seams.
- Fully welded inside and out.
- Truck body is continuously welded for added strength and sanitation.
- Replacement wheels available.
- Drain and cap for easy cleaning.
- Heavy-duty 14-gauge, type 304 stainless steel.

APPROX. DIMENSION SPECIFICATIONS

	A.	B.	C.	D.
800 Pounds	19-1/2"	26-1/4"	45-3/4"	31"
1,100 Pounds	19"	26-3/4"	55-3/4"	30"



Drain and cap for easy cleaning.



ITEM NO.	PRODUCT	SHIPPING WT.	EACH
2990 2988	800 lb Capacity EasyRol Sausage Truck	180 lb.	CALL FOR PRICING
2990 2989	1,100 lb Capacity EasyRol Sausage Truck	200 lb.	CALL FOR PRICING

Aluminum Mobile Dunnage Rack

Transport and store merchandise without having to load or unload.

- Optional tow hook allows rack to be pulled or optional handle available for easier transport.
- Fully washdown and corrosion-resistant.
- 5-inch casters — 2 swivel with brakes and 2 rigid.
- 6-inch x 2-inch polyurethane casters — 2 swivel with brakes and 2 rigid.

NOTE: Optional tow hook or handle, sold separately.



Optional tow hook can be inserted under or over loop.



F.O.B. FACTORY

ITEM NO.	PRODUCT	DIMENSIONS	EACH
3775 0066	Aluminum Mobile Dunnage Rack	20" x 8-1/4" x 49-3/4"	\$371.75
3775 00671	Aluminum Tow Hook	37"	25.15
3775 2862	"Drop-In" Handle	22" x 35"	47.25

Plastic Dunnage Racks

- Keep frozen, cold or dry inventory 12 inches (30.5 cm) safely off the floor.
- One-piece, heavy-duty polypropylene construction is easy to clean.
- Will not rust, corrode or bend.
- Slotted tops for maximum air circulation around perishable products.



NOTE: Includes one Camlink Connector to securely lock multiple racks together.



ITEM NO.	DIMENSIONS	CAPACITY	SHIPPING WT.	EACH
2432 0081	36" x 21" x 12"	1,500 lb	20 lb.	\$196.80
2432 7017	48" x 21" x 12"	3,000 lb	30 lb.	236.85
2432 0067	60" x 21" x 12"	3,000 lb	33 lb.	277.95

Aluminum Dunnage Racks

- Ideal where supplies must be stored off the floor.
- Made entirely of 1-1/2-inch x 1-3/4-inch extruded aluminum.
- Corrosion resistant, all welded and easy to keep clean.
- No openings or crevices to trap dirt.



ITEM NO.	DIMENSIONS	CAPACITY	SHIPPING WT.	EACH
3775 2131	36" x 20" x 12"	3,000 lb	9 lb.	\$125.95
3775 2132	48" x 20" x 12"	2,500 lb	11 lb.	137.45
3775 2133	60" x 20" x 12"	2,000 lb	14 lb.	148.05
3775 2139	36" x 20" x 8"	3,000 lb	9 lb.	125.95
3775 2138	48" x 20" x 8"	2,500 lb	11 lb.	137.55
3775 2137	60" x 20" x 8"	2,000 lb	14 lb.	147.95



Anti-Slip Dunnage Rack Cover Stand

- Ideal for converting dunnage racks to personnel stands.
- Keeps workers elevated off the floor.
- Anti-slip cover made entirely of aluminum with drainage holes.
- Corrosion resistant, all welded and easy to keep clean.

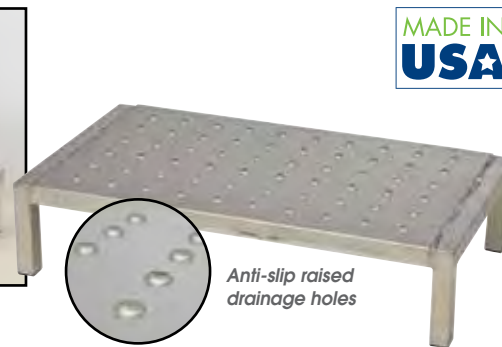

ITEM NO.	DIMENSIONS	CAPACITY	SHIPPING WT.	EACH
3775 21361	Fits 20" x 36" Rack	3,000 lb	11 lb.	\$143.75
3775 21351	Fits 20" x 48" Rack	2,500 lb	14 lb.	216.25
3775 21341	Fits 20" x 60" Rack	2,000 lb	18-1/2 lb	236.15

NOTE: Cover only. Dunnage rack sold separately.

Aluminum Nesting Racks

- Heavy-duty, all welded construction.
- Height: 12 inches.



NOTE: Optional space saving bridge, joins racks to accommodate tight spaces.

ITEM NO.	DIMENSIONS	CAPACITY	SHIPPING WT.	EACH
2510 2024	20" x 12" x 24"	3,000 lb	.8 lb.	\$80.35
2510 2036	20" x 12" x 36"	2,500 lb	.9 lb.	91.75
2510 2048	20" x 12" x 48"	2,000 lb	.17 lb.	100.75
2510 2025	20" x 24" Bridge - Span Limit 8" to 18"		4 lb.	48.35



Aluminum Knockdown Tables

- Knockdown aluminum tables will not rust.
- All tables have an I-under brace for additional support.
- Optional undershelf nests on the frame below the table for convenient storage.
- Optional overshelf allows you to place objects up and out of the way.

BUILD YOUR OWN ALUMINUM KNOCKDOWN TABLE

Choose from three sizes of either a poly or a stainless steel top, and then add your options.

1. Choose your TYPE of table:

- Aluminum Table with Stainless Steel Top.
- Aluminum Table with Stainless Steel Top and Backsplash.
- Aluminum Table with Poly Top.
- Aluminum Table with Poly Top and Backsplash.

2. Choose the SIZE of table:

- 48 inches L x 30 inches D x 34 inches H.
- 72 inches L x 30 inches D x 34 inches H.
- 96 inches L x 30 inches D x 34 inches H.

3. Choose one or both OPTIONS:

- Stainless Steel Undershelf.
- Stainless Steel Overshelf.

NOW, look below at the ordering information box and determine which Product Numbers match the table you have built.

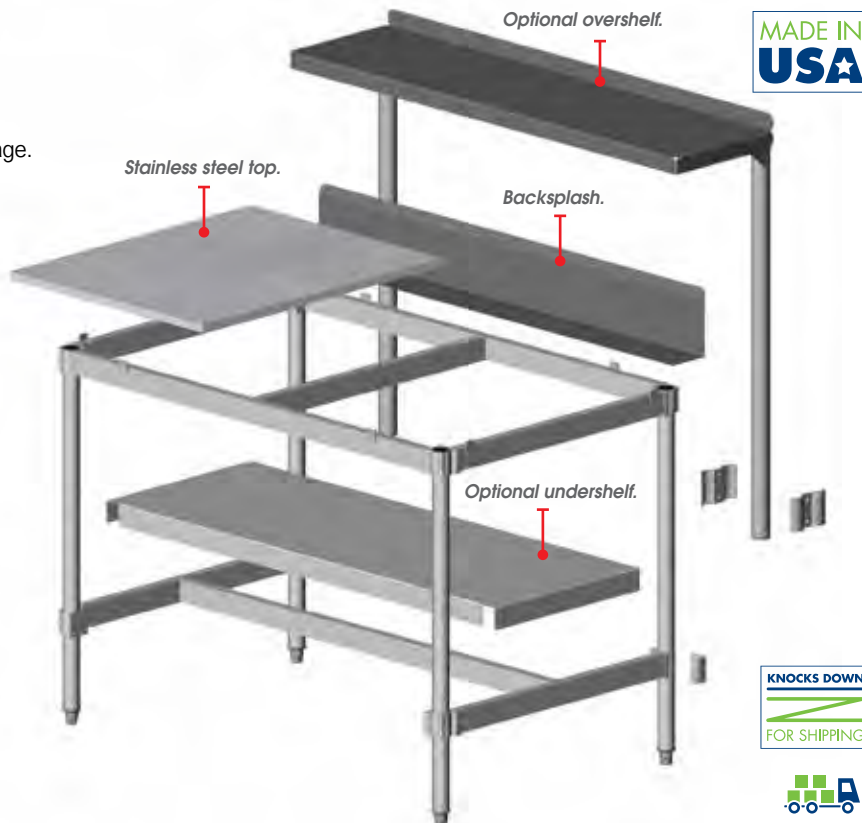

Knockdown Table with Stainless Top

ITEM NO.	SIZE	F.O.B. FACTORY EACH
2510 3449	48" x 30" x 34" (This item can ship UPS)	\$615.85
2510 3473	72" x 30" x 34"	699.85
2510 3497	96" x 30" x 34"	959.75

Table w/ Stainless Top and Backsplash

ITEM NO.	SIZE	EACH
2510 3448	48" x 30" x 34" (This item can ship UPS)	\$627.95
2510 3472	72" x 30" x 34"	952.25
2510 3496	96" x 30" x 34"	1,284.25

Knockdown Table with Poly Top

Poly tops come in multiple pieces for ease of handling.

ITEM NO.	SIZE	POLY TOP PIECES	F.O.B. FACTORY EACH
2510 3450	48" x 30" x 34" (This item can ship UPS)	2	\$488.55
2510 3474	72" x 30" x 34"	3	665.75
2510 3498	96" x 30" x 34"	4	833.35

Knockdown Table w/ Poly Top and Backsplash

ITEM NO.	SIZE	POLY TOP PIECES	EACH
2510 3488	48" x 30" x 34" (This item can ship UPS)	2	\$599.00
2510 3475	72" x 30" x 34"	3	834.95
2510 3499	96" x 30" x 34"	4	1,104.15

Optional Features

Stainless Steel Undershelf

ITEM NO.	SIZE	F.O.B. FACTORY EACH
2510 1848	48" x 18" x 2" (This item can ship UPS)	\$200.35
2510 1872	72" x 18" x 2"	284.35
2510 1896	96" x 18" x 2"	309.55

Optional Features

Stainless Steel Overshelf

ITEM NO.	SIZE	EACH
2510 1248	48" x 12" x 1-1/2" (This item can ship UPS)	\$242.45
2510 1272	72" x 12" x 1-1/2"	368.75
2510 1296	96" x 12" x 1-1/2"	480.65





Stainless Steel Work Tables

Rock Solid • No Wobble • Guaranteed

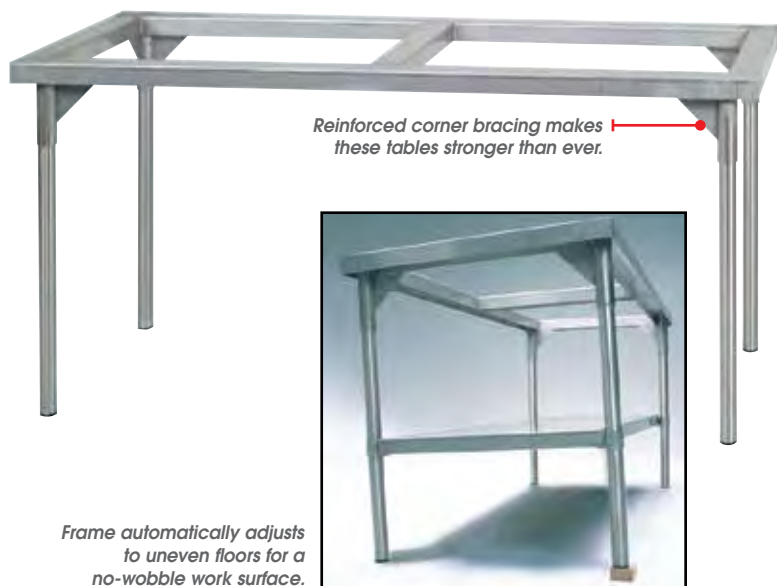

Reinforced corner bracing makes these tables stronger than ever.

Frame automatically adjusts to uneven floors for a no-wobble work surface.



Breaks down for easy shipping.



Clips simplify removal of poly top.



ASSEMBLES IN MINUTES!
The only tool you'll need is an Allen wrench and it's included.



Easily install lower shelf.

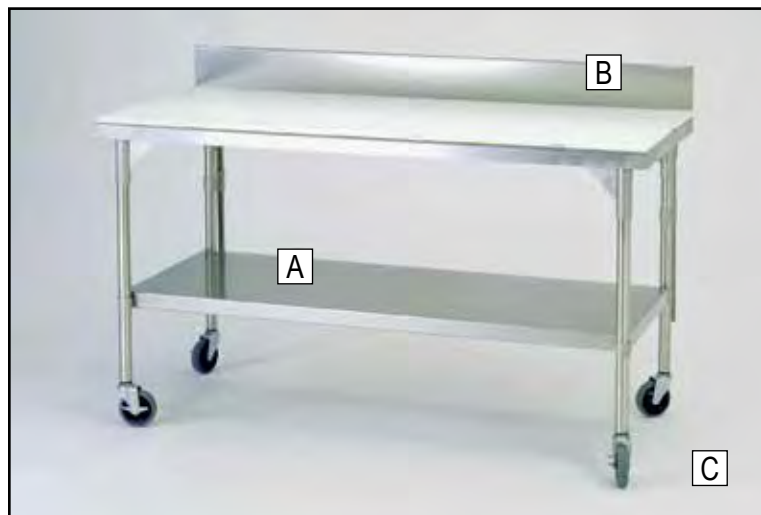

Full Stainless Top on Full Table

F.O.B. FACTORY

ITEM NO.	SIZE	SHIPPING WT.	EACH
2990 2990	72" X 30"	102 lb.	CALL FOR PRICING
2990 2991	96" x 30"	113 lb.	CALL FOR PRICING

Split Poly Top on Full Table

F.O.B. FACTORY

ITEM NO.	SIZE	SHIPPING WT.	EACH
2990 2992	72" X 30"	98 lb.	CALL FOR PRICING
2990 2993	96" x 30"	131 lb.	CALL FOR PRICING

Replacement Clips (for Poly Tables)

ITEM NO.	SIZE	EACH
2990 3254	For 72" Tables	\$11.75

BUILD YOUR OWN STAINLESS STEEL WORK TABLE

1. Start with a "Rock Solid" stainless frame:

- Unique design yields a table which is remarkably rigid front-to-back and side-to-side, yet flexible along its length to twist to accommodate uneven floors. Even with a one inch block under one leg, all legs make solid contact with the floor and the table won't wobble or shake, (see inset). The key is the oversized, welded gussets. Legs are adjustable to level the table.
- Available in 72 or 96 inch lengths x 30 inches deep.

2. Choose from a split-poly or full stainless steel work top

- No tools needed to install either top. Stainless steel clips hold poly top in place. Or, remove the clips and install the full stainless top in minutes. To comply with USDA regulations, the poly top is only available as a two-piece unit.
- 96 inches L x 30 inches D x 34 inches H.

3. Customize to suit your specific needs:

- Stainless Steel Shelf Kit.
- Stainless Steel Backsplash.
- Caster Kit.

A. Lower Stainless Shelf Kits

Fully adjustable stainless steel shelf. Shelf removes easily from clips for washdown, no tools needed.

F.O.B. FACTORY

ITEM NO.	SIZE	SHIPPING WT.	EACH
2990 3250	For 72" Tables	40 lb.	CALL FOR PRICING
2990 3251	For 96" Tables	55 lb.	CALL FOR PRICING

B. Backsplash (for Poly Tables)

Backsplash is available for use with poly top tables.

F.O.B. FACTORY

ITEM NO.	SIZE	SHIPPING WT.	EACH
2990 3248	For 72" Tables	13 lb.	CALL FOR PRICING
2990 3249	For 96" Tables	15 lb.	CALL FOR PRICING

C. Caster Kits

Add mobility with 5 inch diameter casters. Wheels lock at all four corners for stability while working.

ITEM NO.	SIZE	EACH
2990 3255	For 72" Tables (4 Locking Casters)	\$151.95
2990 3256	For 96" Tables (4 Lock, 2 Std.)	202.15

Stainless Steel Knockdown Table

- Available in three lengths with or without a 6-inch stainless steel backsplash and undershelf.
- 16-gauge, Type 304 stainless steel work surface, legs and rails.
- 12-gauge galvanized steel table channels provide maximum stability.
- Ships knocked-down with easy assembly — assembly hardware is included.



Optional 6-inch backsplash available.

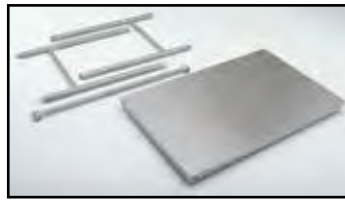

Table ships knocked-down.



Table without backsplash.



Adjustable feet allow for height adjustment.

NOTE: Table with undershelf also available. CALL FOR DETAILS.

F.O.B. FACTORY

ITEM NO.	PRODUCT	DIMENSIONS	EACH
3048 2324	36" Table w/o Backsplash	36" x 24" x 36"	\$808.35
3048 2325	48" Table w/o Backsplash	48" x 24" x 36"	840.75
3048 2326	60" Table w/o Backsplash	60" x 24" x 36"	916.75
3048 1324	36" Table w/Backsplash	36" x 24" x 36"	808.35
3048 1325	48" Table w/Backsplash	48" x 24" x 36"	851.55
3048 1326	60" Table w/Backsplash	60" x 24" x 36"	927.55

Stainless Steel Mini Stuffing Table

- Working surface is crafted from heavy 14-gauge T-304 seamless stainless steel. Rustproof, corrosion resistant and is easy to clean.
- Legs are constructed with 16-gauge polished round stainless steel 1-5/8 inch diameter and with sturdy rigid-truss cross supports.
- Feet and legs allow up to 5 inches of over all height adjustment.
- Ships knocked-down with easy assembly.
- Work surface measures 33 inches deep x 57 inches long and features a slope to a 2-inch sink-type drain and has 1-1/2-inch formed top retaining edges.
- Table is extremely versatile and may be ordered with the Operator Notch section located on either side of the table.



Slope with 2-inch sink-type drain.



ITEM NO.	DIMENSIONS	EACH
2990 1030	33-1/10" x 57-1/10" x 28-3/10"	CALL FOR PRICING

Stainless Steel Stand Alone Table

- Designed to be used in food preparation facilities, kitchens and restaurants.
- Fabricated from heavy-duty 14-gauge T-304 stainless steel.
- Heavy-duty all welded construction makes them ideal as stand-alone equipment stand or to be placed where additional work space is needed.
- Features a full size middle storage shelf and all welded construction.
- This unit is suitable for wet or harsh environments and is easy to clean.
- Equipped with adjustable bullet style feet for easy leveling.



Compact sized table can be used for small kitchen equipment.



NOTE: Arrives FULLY ASSEMBLED!

ITEM NO.	PRODUCT	DIMENSIONS	EACH
2990 1127	SS Stand Alone Table	24" x 20" x 30"	CALL FOR PRICING

24-Inch x 30-Inch Aluminum Knock Down Table with Poly Top

- Made with heavy-duty aluminum frame.
- Includes four non-locking 4-inch casters.
- Available with or without 6-inch backsplash.



NOTE: 50 pound capacity tote INCLUDED!

► SEE PAGES 189 For Additional Tote Colors



Tote slides easily on built-in slide rails.



Optional backsplash.

► SEE PAGES 233 For Locking Casters

ITEM NO.	PRODUCT	DIMENSIONS	F.O.B. FACTORY EACH
2510 3501	Poly Top Table w/Tote	30" x 24" x 34"	\$458.95
2510 3502	Poly Top Table w/Tote and 6" Backsplash		607.95

HOW TO CALCULATE REPLACEMENT CUTTING BOARDS

1. Measure length and width in inches.
2. Multiply length x width for total square inches.
3. Divide total square inches by 144.
4. Round calculation up to the nearest foot.
5. Take that number x price per square foot.

$L \times W = \text{Total Square Inches}$

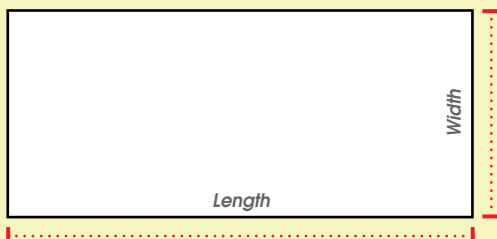

Example:

1. Board desired is 13 inches W x 76 inches L.
2. 13 inches x 76 inches = 988 square feet.
3. 988 divided by 144 = 6.86
4. Round 6.86 up to nearest foot = 7
5. Take 7 x price of board per square foot = Total price

We recommend boards no larger than 18 inches W x 5 feet L, removable for cleaning by a single worker.

Sanatec® Poly Cutting Board Table Tops

An economical alternative to wood surfaces.

- Made of sanitary polyethylene with a reversible slip-resistant pebble finish that won't dull knives.
- Surface will not absorb odors – clean with soap and water.
- Select from four thicknesses, sold per square foot.



CUSTOM CUT to Any Size or Shape to Fit Your Table!

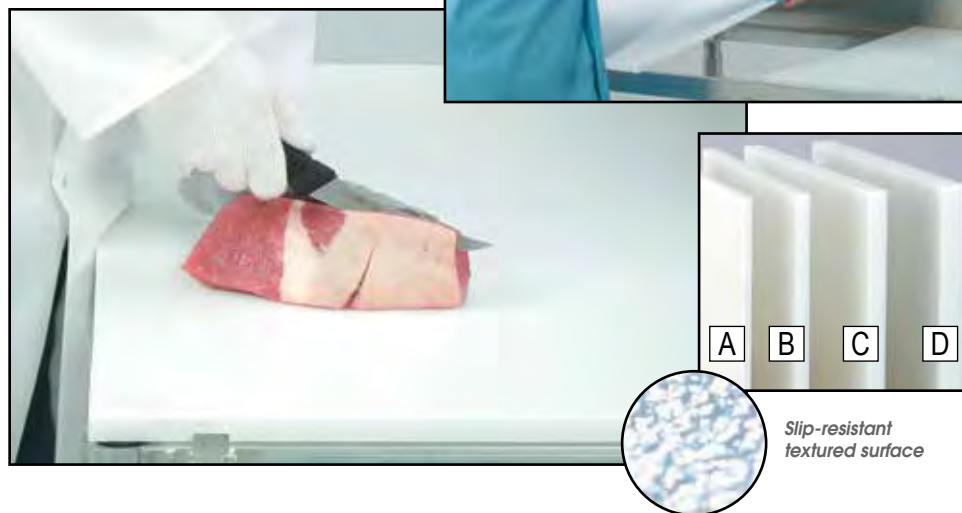

A B C D

Slip-resistant textured surface

ITEM NO.	PRODUCT	F.O.B. FACTORY SQ. FT.
3201 1424	A. 1/4" Cutting Board.....	CALL FOR PRICING
3201 2094	B. 1/2" Cutting Board.....	
3201 1425	C. 3/4" Cutting Board.....	
3201 1426	D. 1" Cutting Board.....	

Call for information on calculating dimensions for replacement cutting boards. Boards 3' x 4' or smaller ship UPS. Larger boards are shipped via freight line.

Pre-Cut Sanatec® for Aluminum Tables

- Specify length of aluminum frame table.
4-foot table requires 2 pieces;
6-foot table requires 3 pieces;
8-foot table requires 4 pieces.
- Removable for easy cleaning.



ITEM NO.	DIMENSIONS	WEIGHT	EACH
3201 2500	30" x 24" x 3/4".....	10 lb.....	CALL FOR PRICING

Colored Cutting Board Table Tops

- 1/2 inch thickness.
- Sold per square foot.



ITEM NO.	COLOR	SQ. FT.
3538 01371	Blue, 1/2" Thick.....	CALL FOR PRICING
3538 01381	Yellow, 1/2" Thick.....	
3538 01391	Red, 1/2" Thick.....	
3538 01401	Green, 1/2" Thick.....	

Cutting Board Scraper/Refinisher



- Removes bacteria-harboring scratches and cuts.
- Dishwasher safe and easy to clean.



► 12 PER CASE.

ITEM NO.	PRODUCT	EACH	
		1-11	12+
6387 17891	Scraper/Refinisher.....	\$44.95	\$43.95
6387 17991	Replacement Blade, 2-pack.....	32.95	---

Polypropylene One-Piece Mixing Paddle Scrapers

- One-piece injection molded polypropylene cleans easily.
- Made from FDA compliant materials.
- Features a lightweight design with a modified T-grip handle.
- Paddle shape and tapered edges allow the scraper to mix product and scrape tubs and vats without damaging the work surface.
- Light-weight but virtually unbreakable.
- Temperature range: -22 °F to 176 °F.
- 40-Inch Paddle: Blade: 6 inches x 13 inches, Overall length: 40 inches, Weight: 2-3/10 pounds.
- 52-Inch Paddle: Blade: 6 inches x 13 inches, Overall length: 40 inches, Weight: 3 pounds.
- Some styles available in 8 colors.



40-Inch Paddles With Holes

ITEM NO.	COLOR
5281 77421	Green
5281 77431	Blue
5281 77441	Red
5281 77451	White
5281 77461	Yellow

52-Inch Paddles With Holes

ITEM NO.	COLOR
5281 77621	Green
5281 77631	Blue
5281 77641	Red
5281 7765	White
5281 77661	Yellow

40-Inch Paddles Without Holes

ITEM NO.	COLOR
5281 7752	Green
5281 77531	Blue
5281 77541	Red
5281 6775	White
5281 77561	Yellow

52-Inch Paddles Without Holes

ITEM NO.	COLOR
5281 77721	Green
5281 7773	Blue
5281 7774	Red
5281 77751	White
5281 77761	Yellow
5281 02651	Orange
5281 02931	Pink
5281 02661	Purple

EACH
\$49.95

EACH
\$60.95

Metal Detectable One-Piece Mixing Paddle Scrapers

- One-piece metal detectable mixing paddles are easy to clean and virtually unbreakable.
- Features a light-weight design with T-grip handle.
- Available in 4 colors.
- Working temperature range: -22 °F/-30 °C to 183 °F/83 °C.
- 52-Inch Paddle: Blade: 6 inches x 13 inches, Overall length: 52 inches, Weight: 3-3/5 pounds.
- Tapered blade for scraping.
- Made from FDA-compliant materials.



► SEE PAGE 10
For More Detectable Products



ITEM NO.	COLOR
5281 0220	Green
5281 0221	Blue
5281 0222	Red
5281 02231	Gray

► 6 PER CASE.

EACH

1-5	6+
\$125.95	\$124.95

Stainless Steel Paddles

Perfect for stirring and mixing bulk products.

- Electropolished finish enhances corrosion resistance; finished surface for ease of cleaning.
- Tough and durable stainless steel mixing paddle has a one-piece, highly smooth finish.
- Seamless stainless steel type 304.

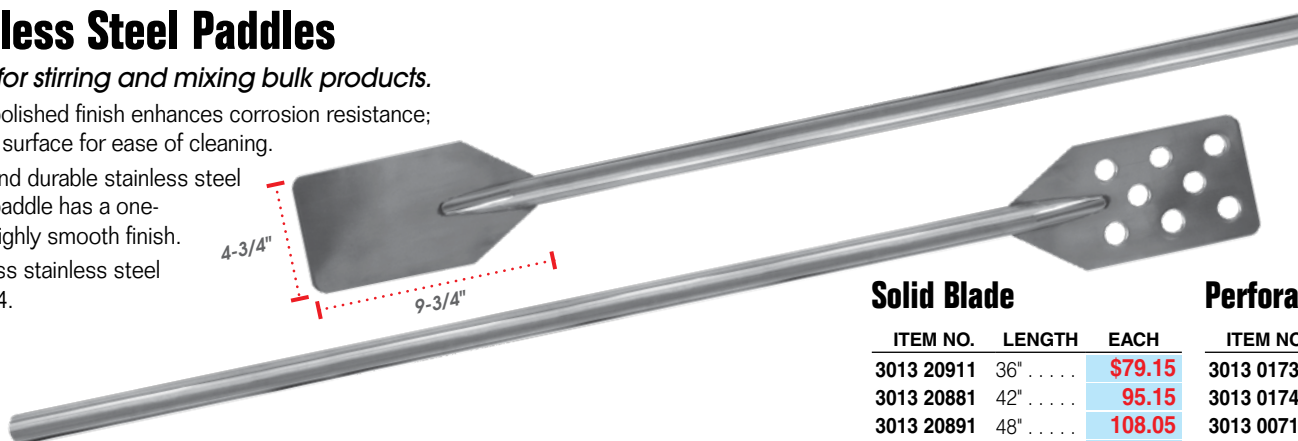

Solid Blade

ITEM NO.	LENGTH	EACH
3013 20911	36"	\$79.15
3013 20881	42"	95.15
3013 20891	48"	108.05
3013 20901	60"	119.75

Perforated Blade

ITEM NO.	LENGTH	EACH
3013 01731	36"	\$87.65
3013 01741	42"	104.75
3013 00711	48"	116.55
3013 01671	60"	131.55





Long Handled Paddle Spatulas



Perfect for stirring, mixing and cleaning kettles, vats and large pots.

- Nylon blade sharpens and contours to your specific needs.
- Smooth, easy-to-clean, waterproof construction won't harbor bacteria.
- Threaded, heavy-duty stainless steel handles have plastic grips to provide comfort and heat resistance when used in high temperature or high viscosity applications.
- Available with stainless steel or nylon handles.
- BPA free. • Blade: 4-1/2 inches x 7-1/2 inches.



► 6 PER CASE.

ITEM NO.	PRODUCT	EACH	
		1-5	6+
6387 00421	40" Nylon Handled Spatula, White	\$42.95	\$41.95
6387 52051	40" Nylon Handled Spatula, Red	43.25	42.25
6387 16761	40" Nylon Handled Spatula, Yellow	43.25	42.25
6387 17861	40" Nylon Handled Spatula, Green	43.25	42.25
6387 17871	40" Nylon Handled Spatula, Blue	43.25	42.25
6387 54001	48" Stainless Steel Handled Spatula, White	122.85	120.85
6387 95001	72" Stainless Steel Handled Spatula, White (Not Shown)	142.25	140.25
6387 61121	4-1/2" x 7-1/2" Nylon Replacement Blade, White	21.45	20.45

Stainless Steel Dough Hoe

- Electropolished finish to enhance corrosion resistance, improve surface finish and ease of cleaning.
- Blade is smooth and easy to clean.
- T-Handle design.
- Blade 7 inches x 10 inches.
- Overall length 60 inches.



SANI-LAV
COLUMBIA PRODUCTS

ITEM NO.	MFR. NO.
3013 20271	2077

EACH
\$266.35

Vikan® Ultra Hygiene Poly Handles



- Easy to clean rounded grip handles.
- Made of food-grade polypropylene, safe alternative to fiberglass.
- Larger diameter ergonomic handle shape reduces worker fatigue.
- Hygienic smooth surface, sealed to prevent bacterial growth.

For More Options ► SEE PAGE 111



51-Inch Handle

ITEM NO.	COLOR	ITEM NO.	COLOR
5281 86051	White	5281 86021	Green
5281 96061	Yellow	5281 96091	Black
5281 86071	Orange		
5281 16041	Red		
5281 96011	Pink		
5281 96081	Purple		
5281 86031	Blue		

► 10 PER CASE.

EACH	
1-9	10+
\$28.95	\$27.95

Vikan Paddle Scraper



- Requires a hygienic European-thread handle.
- Choose from stiff or flexible.
- 4-3/10 inches W x 1 inch L x 8-3/4 inches H.



NOTE: Requires a Vikan® Euro-threaded handle, sold separately. SEE ABOVE.



Stiff

For substances requiring significant pressure.

ITEM NO.	COLOR
5281 03601	Green
5281 01131	Blue
5281 01141	Red
5281 00931	White
5281 01161	Yellow

Flexible

Functions as a spatula, making scraping container surfaces easy.

ITEM NO.	COLOR
5281 03611	Green
5281 01331	Blue
5281 01341	Red
5281 70131	White
5281 71361	Yellow

EACH
\$16.95

Food Hoe

Made from FDA compliant materials.

- Injection molded nylon construction.
- Chemical and corrosion resistant.
- Maximum working temp: 300 °F.
- Ideal for cleaning cylindrical containers.
- 8 inches x 11 inches.

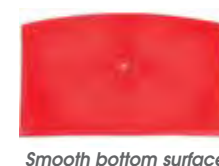

ITEM NO.	COLOR
5281 90021	Green
5281 90031	Blue
5281 90041	Red
5281 9005	White
5281 90061	Yellow

EACH
\$28.95

Requires a Vikan® Euro-threaded handle, sold separately. SEE ABOVE.

Standard Stainless Steel Shovels

- Durable stainless makes this shovel perfect for moving bulk materials.
- Electropolished finish enhances corrosion resistance.
- Welds are ground smooth for improved surface finish and ease of cleaning.
- No cracks or crevices that can trap debris or bacteria.
- Back of blade is smooth for easy cleaning.
- Certified NSF Standard 2 — food equipment.

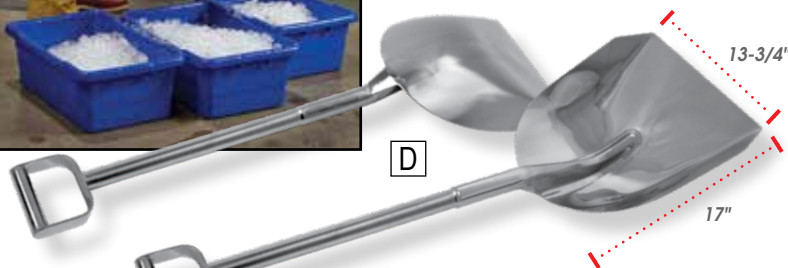
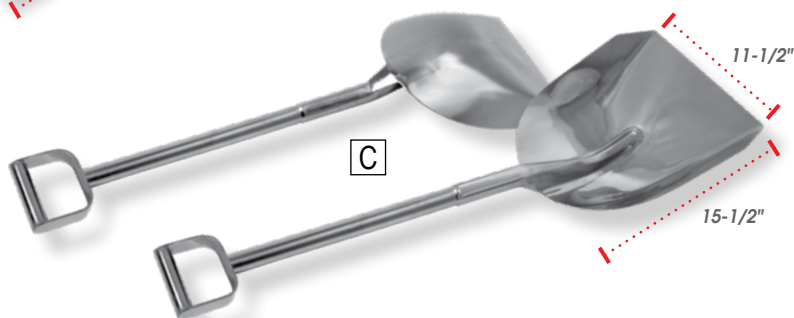
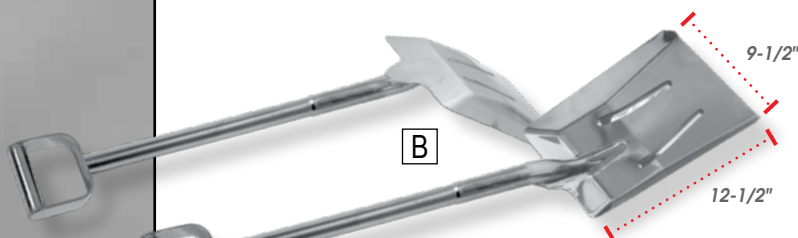
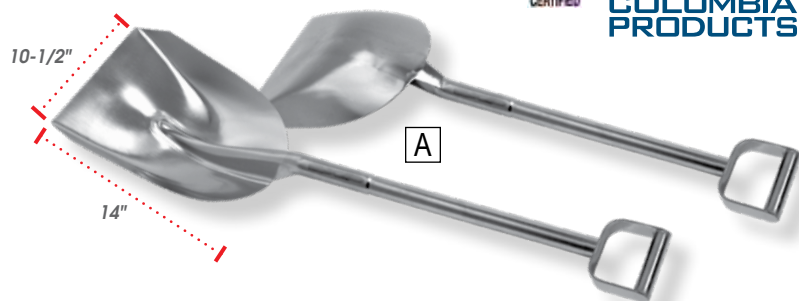

ITEM NO.	BLADE DIMENSIONS	OVERALL LENGTH	WEIGHT	EACH	
				1-5	6+
3013 02071	A. 10-1/2" x 14"	40"	5 lb.	\$221.45	\$217.45
3013 0217	B. 9-1/2" x 12-1/2"	40"	6 lb.	228.95	226.95
3013 0227	C. 11-1/2" x 15-1/2"	40"	8 lb.	235.35	232.35
3013 01591	D. 13-3/4" x 17"	44"	10 lb.	267.45	264.45

▶ 6 PER CASE.

Standard Stainless Steel Spade



▶ 6 PER CASE.

ITEM NO.	BLADE DIMENSIONS	OVERALL LENGTH	WEIGHT	EACH	
				1-5	6+
3013 02671	7" x 11"	39"	.6 lb.	\$228.95	\$226.95

Standard Cast-Aluminum Shovel

Lightweight, durable one-piece construction stands up to rugged use.



▶ 6 PER CASE.

ITEM NO.	BLADE DIMENSIONS	OVERALL LENGTH	WEIGHT	EACH	
				1-5	6+
3086 1100	11" x 14"	38"	5-1/5 lb	\$63.95	\$61.95

Reinforced Stainless Steel Shovels

- Reinforced stainless steel construction makes this shovel perfect for moving bulk materials.
- Electropolished finish enhances corrosion resistance.
- No cracks or crevices that can trap debris or bacteria.
- Certified NSF Standard 2-food equipment.

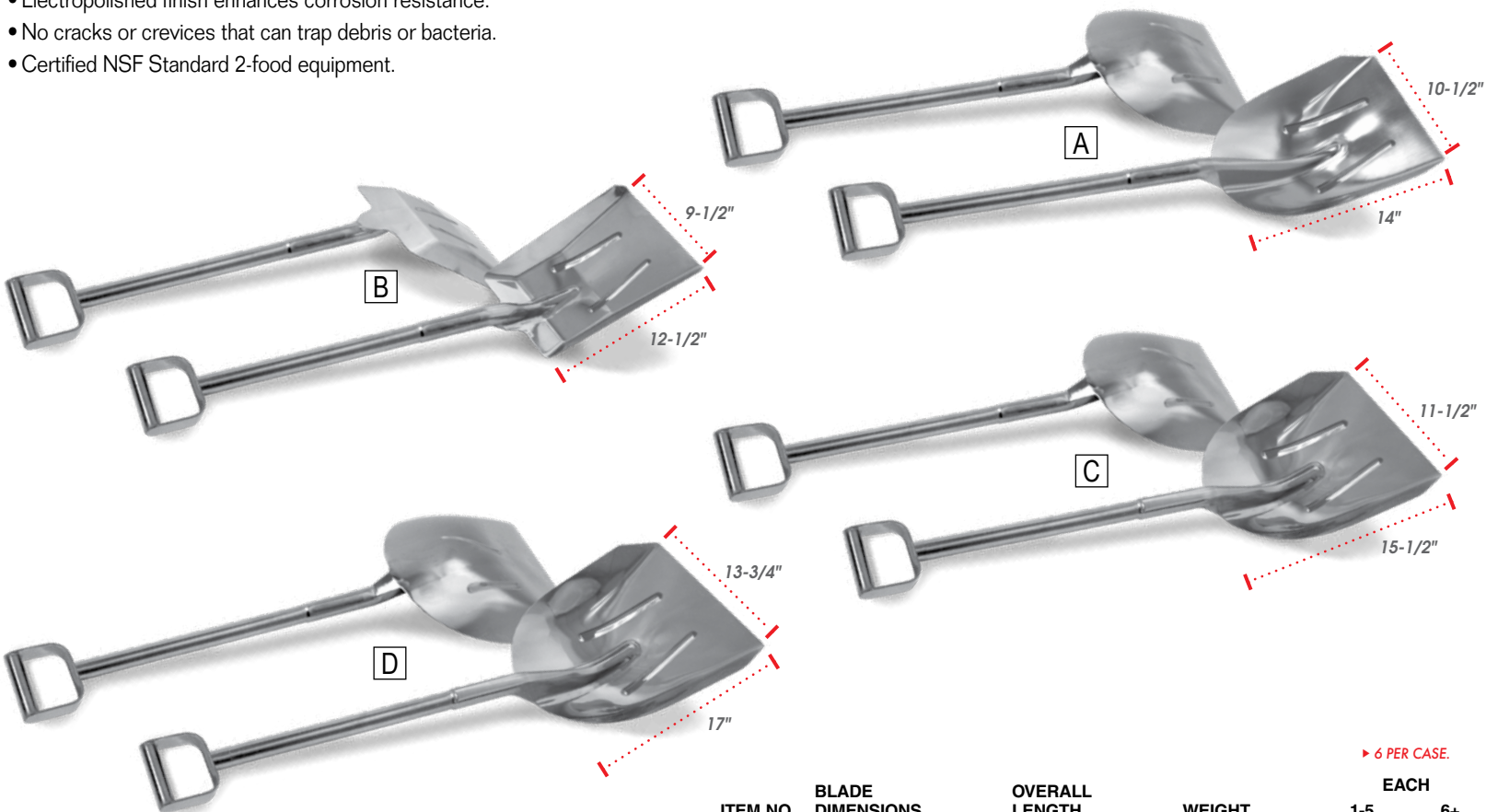

▶ 6 PER CASE.

ITEM NO.	BLADE DIMENSIONS	OVERALL LENGTH	WEIGHT	EACH	
				1-5	6+
3013 02081	A. 10-1/2" x 14"	40"	5 lb.	\$235.35	\$232.35
3013 12171	B. 9-1/2" x 12-1/2"	40"	6 lb.	235.35	232.35
3013 02281	C. 11-1/2" x 15-1/2"	40"	8 lb.	248.15	246.15
3013 01601	D. 13-3/4" x 17"	44"	10 lb.	278.15	275.15

Reinforced Stainless Steel Spade

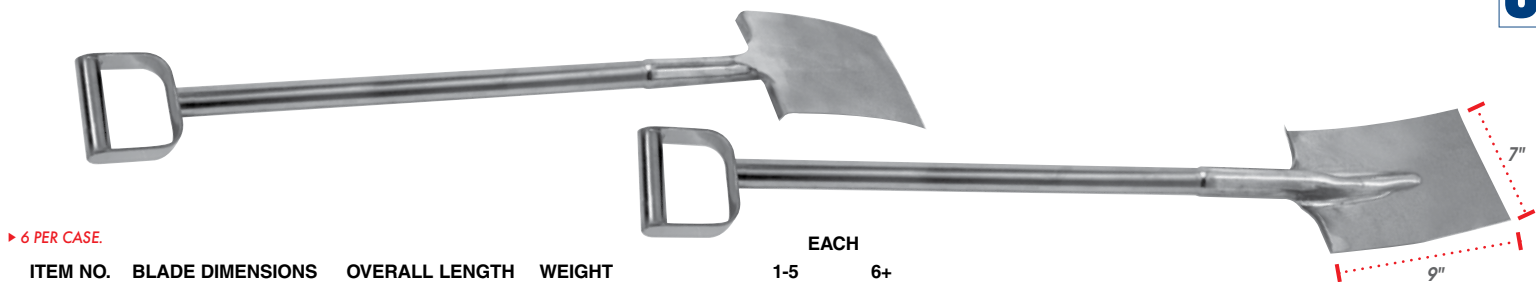

▶ 6 PER CASE.

ITEM NO.	BLADE DIMENSIONS	OVERALL LENGTH	WEIGHT	EACH	
				1-5	6+
3013 02691	7" x 9"	39"	6 lb.	\$235.35	\$232.35

Square Steel Shovel with Fiberglass Handle

- Square point forged steel blade.
- Ergonomically shaped for comfort.
- 47-inch handle.



▶ 6 PER CASE.

ITEM NO.	BLADE DIMENSIONS	OVERALL LENGTH	WEIGHT	EACH	
				1-5	6+
7146 00081	9-3/4" x 10-2/5"	57-2/5"	4-3/5 lb	\$35.95	\$34.95

SHOVELS AND SPADE

PRICES ARE SUBJECT TO CHANGE • MINIMUMS MAY APPLY • VISIT OUR WEBSITE FOR CURRENT PRICING.

Plastic Shovels

- Sturdy injection molded one-piece polypropylene. • Features a solid shaft and extra thick blade.
- Non-sparking. • Made from FDA compliant materials. • Chemical- and corrosion-resistant.
- Small Blade: 11 inches x 14 inches; Overall length: 38 inches; Weight: 2-7/10 pounds.
Large Blade: 14 inches x 17 inches; Overall length: 42 inches; Weight: 4 pounds.



Small Blade

ITEM NO.	COLOR		
5281 98101	White		
5281 69801	Yellow		
5281 01081	Orange		
5281 00081	Red		
5281 00271	Pink		
5281 01091	Purple		
5281 98131	Blue		
5281 04791	Lime		
5281 98121	Green		
5281 04781	Brown		
5281 04801	Gray		
5281 01481	Black		
		1-5	6+
		\$39.95	\$38.95

Large Blade

ITEM NO.	COLOR		
5281 98251	White		
5281 69891	Yellow		
5281 98271	Orange		
5281 69831	Red		
5281 01591	Pink		
5281 69921	Purple		
5281 69881	Blue		
5281 04951	Lime		
5281 69901	Green		
5281 04941	Brown		
5281 04961	Gray		
5281 98291	Black		
		1-5	6+
		\$40.95	\$39.95

Metal Detectable One-Piece Shovels

- One-piece, injection molded. • Made from FDA compliant materials.
- Working temperature range: -22 °F/-30 °C to 176 °F/80 °C
- Heavy-duty and resilient. • Corrosion-resistant. • D-grip handle.
- Small Blade: 11 inches x 14 inches; Overall length: 38 inches.
Large Blade: 14 inches x 17 inches; Overall length: 42 inches.

Small Blade

ITEM NO.	COLOR		
5281 02001	Green		
5281 02011	Blue		
5281 02021	Red		
5281 02031	Gray		
		1-5	6+
		\$125.95	\$124.95

Large Blade

ITEM NO.	COLOR		
5281 02101	Green		
5281 02111	Blue		
5281 02121	Red		
5281 02131	Gray		
		1-5	6+
		\$162.95	\$161.95



Non Food Contact Shovel

- Sturdy injection molded one-piece polypropylene.
- Features a solid shaft and extra thick blade.
- Constructed of regrind and recycled materials.
- Not for food contact.

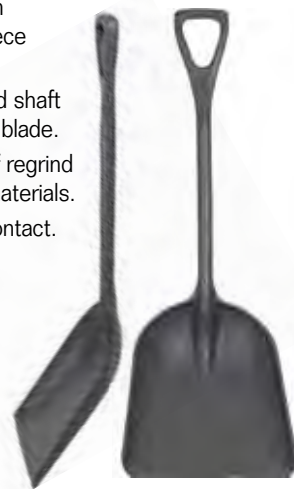

ITEM NO.	SIZE	EACH
5281 0006	11" x 14"	\$34.95
5281 11051	14" x 17"	\$38.95

Ergonomic Color-Coded Shovels

The shovel designed to get the job done without doing a number on your back!

- Ergonomic design reduces strain when lifting from the floor level.
- Heavy-duty, one-piece, injection molded polypropylene construction.
- Working temperature range: -22 °F/-30 °C to 176 °F/80 °C.
- Blade: 14 inches x 18 inches, Overall length: 48 inches.
- Features a D-grip extended handle.
- Made from FDA compliant materials.
- Chemical and corrosion resistant.

ITEM NO.	COLOR		
5281 98451	White		
5281 98441	Red		
5281 98421	Green		
5281 98431	Blue		
5281 98461	Yellow		
		1-5	6+
		\$54.95	\$52.95



Ergonomic dual grip handles.



PRICES ARE SUBJECT TO CHANGE • MINIMUMS MAY APPLY • VISIT OUR WEBSITE FOR CURRENT PRICING.

Standard Stainless Steel Forks

- Electropolished finish to enhance corrosion resistance, improve surface finish and ease of cleaning.
- Overall lengths: (A) 60 inches, (B, C, D, E) 44 inches.



SANI-LAV
COLUMBIA
PRODUCTS

MADE IN
USA

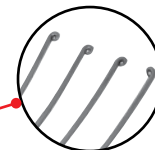
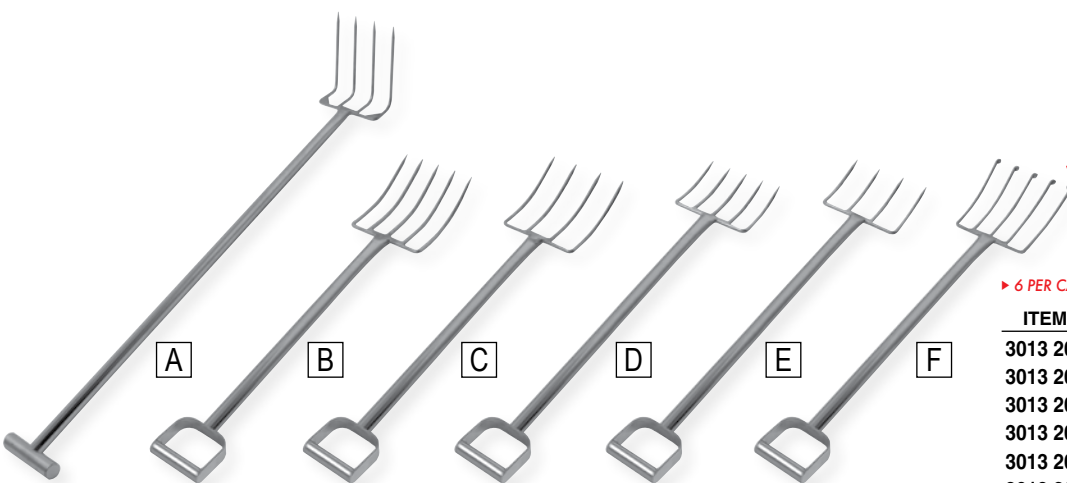

Cheese fork has curled end tines.

▶ 6 PER CASE.

ITEM NO.	PRODUCT	EACH	
		1-5	6+
3013 2075	A. 4 Tine, 9" Drag Fork	\$259.95	\$256.95
3013 2071	B. 5 Tine, 12" Standard Fork	247.05	244.05
3013 2073	C. 4 Tine, 12" Standard Fork	247.05	244.05
3013 2072	D. 5 Tine, 8-1/2" Standard Fork	247.05	244.05
3013 2074	E. 4 Tine, 8-1/2" Standard Fork	247.05	244.05
3013 20851	F. 5 Tine, 10" Cheese Fork	253.55	251.55

Reinforced Stainless Steel Forks

- Stainless steel plate welded across tines for added rigidity.
- Overall lengths: (A) 60 inches, (B, C, D, E) 44 inches.

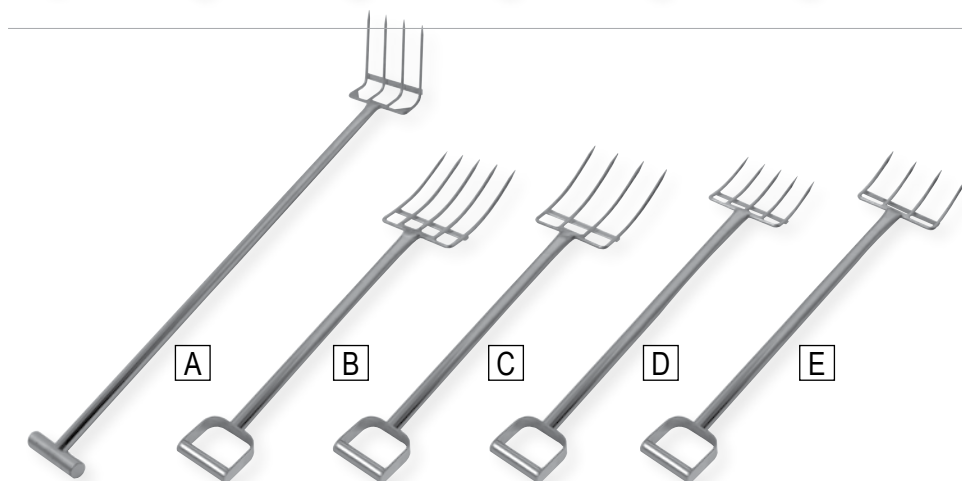

▶ 6 PER CASE.

ITEM NO.	PRODUCT	EACH	
		1-5	6+
3013 2077	A. 4 Tine, 9" Drag Fork	\$330.55	\$326.55
3013 2070	B. 5 Tine, 12" Standard Fork	298.45	296.45
3013 2079	C. 4 Tine, 12" Standard Fork	298.45	296.45
3013 2069	D. 5 Tine, 8-1/2" Standard Fork	298.45	296.45
3013 2080	E. 4 Tine, 8-1/2" Standard Fork	298.45	296.45

Super Reinforced Stainless Steel Forks

- Reinforced support brackets and heavy-duty welds for strength.
- Heavy-duty tines are 33% thicker.
- Overall lengths: (A) 60 inches, (B, C, D, E) 44 inches.

▶ 6 PER CASE.

ITEM NO.	PRODUCT	EACH	
		1-5	6+
3013 20821	A. 4 Tine, 6-1/2" Drag Fork	\$339.15	\$336.15
3013 21711	B. 5 Tine, 12" Standard Fork	339.15	336.15
3013 21731	C. 4 Tine, 12" Standard Fork	339.15	336.15
3013 20831	D. 5 Tine, 8-1/2" Standard Fork	339.15	336.15
3013 20841	E. 4 Tine, 8-1/2" Standard Fork	339.15	336.15

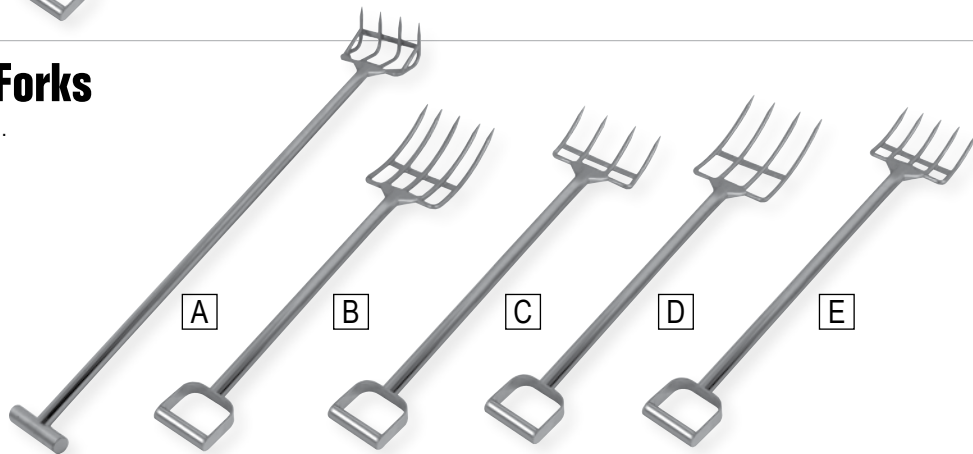

Vikan® Hygienic Fork and Rake

An innovative alternative to stainless steel.

- Made from FDA compliant materials.
- Working temperature of between -22 °F/-30 °C to 176 °F/80 °C.
- Light-weight injection molded polypropylene chemical and corrosion-resistant.
- Fork Dimensions: 10-1/2 inches x 10-1/2 inches x 49 inches.
- Rake Dimensions (without 51-inch handle): 8 inches x 8 inches.

▶ 10 PER CASE.

ITEM NO.	PRODUCT	EACH	
		1-9	10+
5281 99051	A. Hygienic Plastic Fork	\$104.95	\$103.95
5281 99151	B. Hygienic Plastic Rake (Order Handle Separately)	42.95	41.95
5281 86051	C. 51" Vikan Ultra Hygiene Handle	28.95	27.95

NOTE: Rake (B) shown with 51-inch white, Vikan® Ultra Hygiene Handle, sold separately.

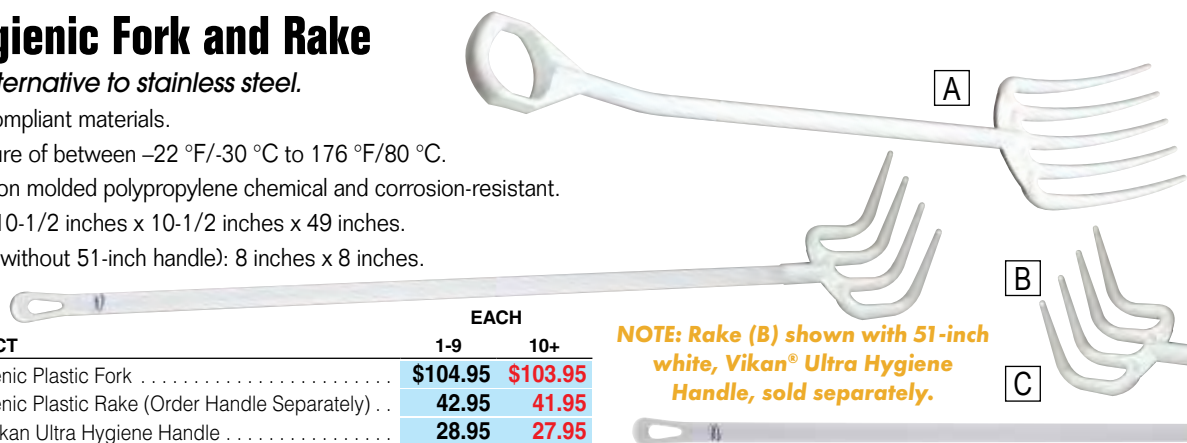

PRICES ARE SUBJECT TO CHANGE • MINIMUMS MAY APPLY • VISIT OUR WEBSITE FOR CURRENT PRICING.

Food Storage Containers

Lids allow for easily recorded food and date information.

- Temperature range from -20 °F to 212 °F.
- NSF certified and commercial dishwasher safe.
- Positive locking lids have gripper ring.
- Stain-resistant.
- Seamless white containers are easy-to-clean and stain-resistant.



▶ 12 PER CASE.

ITEM NO.	PRODUCT	DIMENSIONS	EACH	
			1-11	12+
1770 20241	2 qt.	8-1/2" dia. x 4-1/4"	\$4.95	\$3.95
1770 76681	4 qt.	8-1/2" dia. x 7.1"	6.95	5.95
1770 57231	6 qt.	10" dia. x 7-9/10"	7.95	6.95
1770 57241	8 qt.	10" dia. x 10-3/5"	9.95	8.95
1770 04421	Lid for 2 and 4 qt. Containers, Yellow		4.95	3.95
1770 57251	Lid for 6 and 8 qt. Containers, Yellow		4.95	3.95

▶ 6 PER CASE.

ITEM NO.	PRODUCT	DIMENSIONS	EACH	
			1-5	6+
1770 57261	12 qt.	3-1/10" dia. x 8"	\$14.95	\$13.95
1770 57281	22 qt.	13-1/10" dia. x 14"	21.95	20.95
1770 15181	22 qt w/Bail	13-1/10" dia. x 14"	26.95	25.95
1770 57301	Lid for 12 and 22 qt. Containers, Yellow		8.95	7.95

High-Heat Spatulas and Spoons

Dishwasher safe scrapers resist heat up to 500 °F/260 °C.

- Stain- and scratch-resistant design protects grill and cookware.
- Handle is always cool to the touch, even when used in the hottest of applications.
- Clean-Rest™ feature keeps blade off surface, reducing cross-contamination.



Molded-in hook allows for easy attachment to a pan.

Notched scraper blade cleanly scrapes sides of pans.



Choose from spoon or spatula heads.

▶ 24 PER CASE.

ITEM NO.	PRODUCT	EACH	
		1-23	24+
1770 19661	9-1/2" Spoon	\$17.95	\$16.95
1770 19671	13-1/2" Spoon	20.95	19.95
1770 19681	16-1/2" Spoon	25.95	24.95
1770 06601	9-1/2" Spatula	17.95	16.95
1770 06591	13-1/2" Spatula	20.95	19.95
1770 19641	16-1/2" Spatula	25.95	24.95

StorPlus™ Polycarbonate Square Food Storage Container



- Clear polycarbonate containers showcases inside contents while providing exceptional durability. Can withstand temperatures from -40 °F to 212 °F.
- Economical white polyethylene containers withstand temperatures from -40 °F to 180 °F. • NSF Listed; dishwasher safe.



Lid color matches container's printed measurements.

Smooth interior finish makes cleanup easy.

Accurately printed measurements keep track of remaining contents.

Wide, build-in handles on all sizes provide a more secure grip and facilitate fast drying.

Stacking lugs save space by preventing jamming.

Clear

▶ 6 PER CASE.

ITEM NO.	PRODUCT	DIMENSIONS	EACH	
			1-5	6+
6387 10721	2 qt.	7.13" dia. x 3-4/5"	\$5.95	\$4.95
6387 10731	4 qt.	7.13" dia. x 7-3/10"	7.95	6.95
6387 10741	6 qt.	8-3/4" dia. x 7-3/10"	10.95	9.95
6387 10751	8 qt.	8-3/4" dia. x 9"	12.95	11.95
6387 10761	12 qt.	11-1/10" dia. x 8-1/4"	16.95	15.95
6387 16861	18 qt.	11-1/10" dia. x 12-3/5"	24.95	23.95
6387 03411	22 qt.	11-1/10" dia. x 15-7/10"	31.95	30.95

White

ITEM NO.	PRODUCT	DIMENSIONS	EACH	
			1-5	6+
6387 09891	2 qt.	7-1/10" dia. x 3-4/5"	\$3.95	\$3.55
6387 09911	4 qt.	7-1/10" dia. x 7-3/10"	5.95	4.95
6387 09851	6 qt.	8-3/4" dia. x 7-3/10"	6.95	5.95
6387 09861	8 qt.	8-3/4" dia. x 9"	8.95	7.95
6387 34021	12 qt.	11-1/10" dia. x 8-1/4"	11.95	10.95
6387 10841	18 qt.	11-1/10" dia. x 12-3/5"	15.95	14.95
6387 10861	22 qt.	11-1/10" dia. x 15-7/10"	19.95	18.95

StorPlus™ Square Container Lids

- Pull tab makes container opening quick and easy.
- Fitted lids limit exposure to environmental contaminants.
- Recessed interior stackable design saves space.
- Durable polyethylene resists warping.
- NSF Listed as N10740.



Color-coded based on lid size.



Lids

ITEM NO.	PRODUCT	EACH	
		1-5	6+
6387 10781	Lids for 2 and 4 qt., Dark Green	\$3.95	\$2.95
6387 10791	Lids for 6 and 8 qt., Red	4.55	3.55
6387 10801	Lids for 12, 18 and 22 qt., Blue	4.95	3.95

Measuring Cups

Crystal-clear material makes measuring easy.



- Molded handle will not break off.
- Dishwasher safe; not affected by food acids.
- Measurements cannot be scratched, chipped or washed off.
- Printed on one side in metric and on the other in standard measurements.



▶ 12 PER CASE.

ITEM NO.	PRODUCT	EACH	
		1-11	12+
2432 02511	1 Cup	\$6.95	\$5.95
2432 02491	1 Pint (2 Cups)	9.95	8.95
2432 03101	1 Quart (4 Cups)	11.95	10.95
2432 02521	2 Quart (8 Cups)	14.95	13.95
2432 60031	4 Quart (1 Gallon)	15.95	14.95

Measuring Cups and Spoons



- Made of FDA compliant materials.
- Capacities clearly engraved for easy identification.
- Secured with detachable ring.
- Accurate ingredient portioning to manage food costs.
- Commercial dishwasher safe.
- Measuring Cup Set includes 1/4, 1/3, 1/2 and 1 cups.
- Measuring Spoon Set includes 1/8 tsp., 1/4 tsp., 1/2 tsp., 1 tsp., 1/2 Tbsp., 1 Tbsp.



▶ 12 PER CASE.

ITEM NO.	PRODUCT	EACH	
		1-11	12+
1770 83161	Measuring Spoon Set	\$4.95	\$3.95
1770 83151	Measuring Cup Set	4.95	3.95

2-Cup Safety Portioning Scoop

- Anti-roll design prevents handle from coming into contact with food, reducing cross-contamination.
- Clear polycarbonate allows for use in cold or hot environments (-40 °F to 212 °F/-40 °C to 100 °C).
- Measurement markings in cups, ounces and milliliters.
- Unique flat front provides access to corners and bottom of pan.
- Dishwasher safe.

▶ 12 PER CASE.

ITEM NO.	PRODUCT	EACH	
		1-11	12+
1770 55561	2 Cup	\$13.95	\$12.95



▶ SEE PAGE 208-209

THIS SCOOP WORKS GREAT WITH OUR PROSAVE™ INGREDIENT SYSTEM



PRICES ARE SUBJECT TO CHANGE • MINIMUMS MAY APPLY • VISIT OUR WEBSITE FOR CURRENT PRICING.

Stainless Steel Industrial Scoops

Certified NSF/ANSI Standard 2 Food Equipment.

- Constructed from heavy-duty 18-gauge type 304 stainless steel.
- Fully welded to ensure that there are no spaces where any particles can gather.
- Completely seamless with large radiused ends that ensure easy cleaning.
- Designed for heavy usage and hygienic applications.

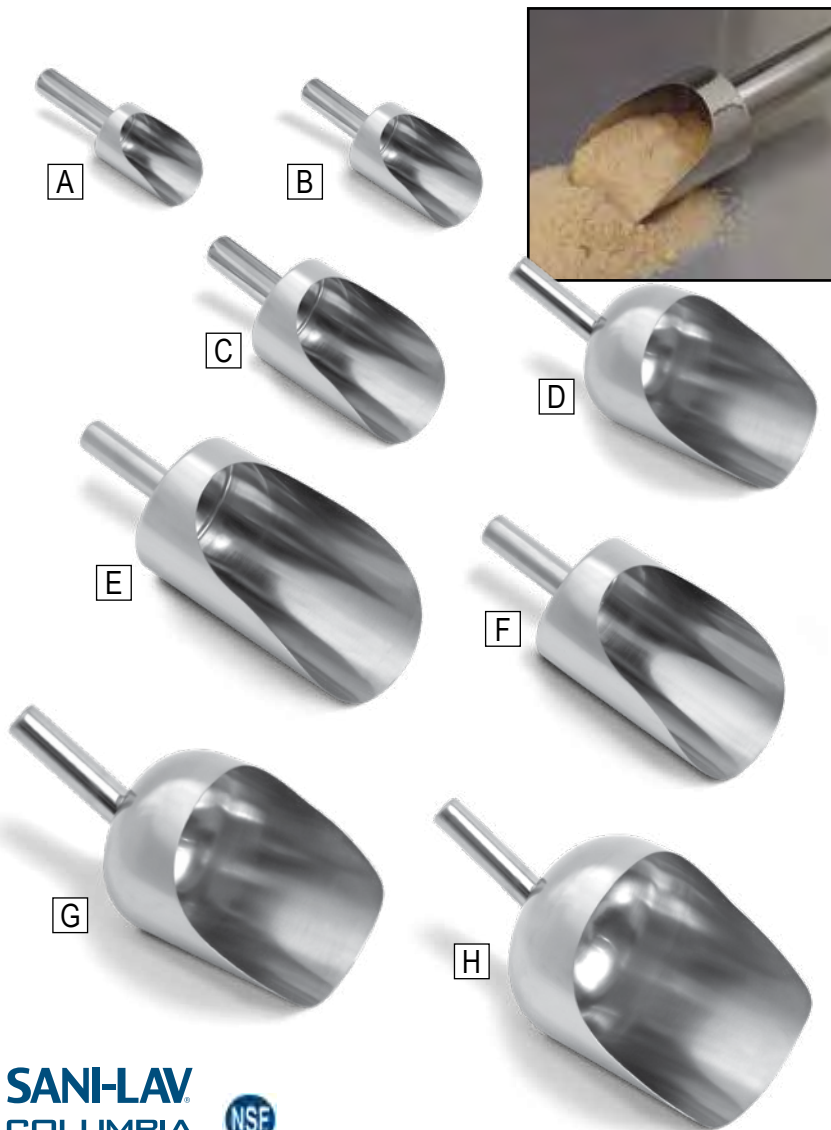

SANI-LAV
COLUMBIA PRODUCTS



► 6 PER CASE.

ITEM NO.	CAPACITY	BOWL DIMENSIONS	EACH	
			1-5	6+
3013 3997	A. 8 oz./1/2 Pint	2-3/4" x 4"	\$76.95	\$74.95
3013 4002	B. 16 oz./1 Pint	3-3/4" x 5"	81.25	79.25
3013 4003	C. 32 oz./1 qt.	4-1/2" x 6-5/8"	87.65	85.65
3013 01681	D. 52 oz. (1-5/8 qt.)	5-1/4" x 5-1/4"	101.55	97.55
3013 9004	E. 64 oz./2 qt.	5" x 8-1/4"	103.75	100.75
3013 4005	F. 96 oz./3 qt.	5-1/2" x 9-1/2"	114.45	112.45
3013 3998	G. 128 oz./1 Gallon	6-1/4" x 8-1/2"	117.65	115.65
3013 3999	H. 1,608 oz./5 qt.	8-1/2" x 10"	131.55	129.55

**BUY IN CASE QUANTITIES
AND SAVE MONEY!**



Stainless Steel Pharma Scoops

Certified NSF/ANSI Standard 2 Food Equipment.

- Ideal for use powders and granules or any hygienic application.
- Constructed from heavy-duty type 316, stainless steel that is highly resistant to corrosion.
- Fully welded to ensure that there are no spaces for particles to gather.
- Completely seamless, with large radiused ends to insure easy cleaning.



SANI-LAV
COLUMBIA PRODUCTS

► 6 PER CASE.

ITEM NO.	CAPACITY	BOWL DIMENSIONS	HANDLE	EACH	
				1-5	6+
3013 00431	A. 8 oz.	4" x 6"	Straight 5"	\$67.35	\$65.35
3013 00441	B. 16 oz.	5" x 7-3/4"	Straight 5"	87.65	85.65
3013 00401	C. 32 oz.	5" x 9"	Straight 5"	94.15	92.15
3013 00411	D. 50 oz.	5-1/2" x 9"	Straight 5"	117.65	115.65
3013 01691	E. 32 oz.	4-7/8" x 6"	Curved 6"	98.35	96.35

Aluminum Scoops

- High-quality, stain-resistant aluminum alloy.
- One-piece, smooth finish casting.



► 6 PER CASE.

ITEM NO.	CAPACITY	BOWL DIMENSIONS	EACH	
			1-5	6+
3009 07041	22 oz.	4" x 7"	\$13.95	\$12.95
3009 07051	36 oz.	5" x 8-1/4"	18.95	17.95
3009 07061	56 oz.	5-1/2" x 10-1/4"	21.95	20.95

White Plastic Scoop



- Dimensions: 6 inches x 9 inches x 3-1/4 inches.
- Made of sanitary, seamless injection-molded white poly.
- Capacity: 5 pints.



▶ 6 PER CASE.

ITEM NO.	PRODUCT	EACH	
		1-5	6+
3049 25151	5-Pint Scoop	\$5.95	\$4.95

Bouncer® Scoops



- NSF certified and commercial dishwasher safe.
- Made of clean, durable polycarbonate.
- Large grip with hole for hanging.
- Easy to clean.
- Light-weight.



▶ 12 PER CASE.

ITEM NO.	PRODUCT	EACH	
		1-11	12+
1770 78201	32 oz. Scoop	\$14.95	\$13.95

▶ 6 PER CASE.

ITEM NO.	PRODUCT	EACH	
		1-5	6+
1770 78241	64 oz. Scoop	\$15.95	\$14.95

Dur-X™ Utility Scoop



- Designed for better weight distribution and improved handling.
- Made of heavy-duty, polyethylene with smooth easy-to-clean surface, dishwasher safe.



▶ 6 PER CASE.

ITEM NO.	PRODUCT	EACH	
		1-5	6+
1770 78221	64 oz. Scoop	\$11.95	\$10.95

Colored Plastic Scoops



- Can be sterilized and stacked for storage.
- One-piece molded polypropylene.
- Capacity: Mini: 16 ounce; Small: 32 ounce; Large: 82 ounce.
- Chemical-resistant.

Mini 16 Ounce

ITEM NO.	COLOR
5281 30051	White
5281 30061	Yellow
5281 30071	Orange
5281 30041	Red
5281 03451	Pink
5281 30081	Purple
5281 30031	Blue
5281 04821	Lime
5281 30021	Green
5281 04811	Brown
5281 04831	Gray

Small 32 Ounce

ITEM NO.	COLOR
5281 64001	White
5281 40061	Yellow
5281 40051	Orange
5281 64021	Red
5281 40011	Pink
5281 40081	Purple
5281 64031	Blue
5281 04851	Lime
5281 64011	Green
5281 04841	Brown
5281 04871	Gray

Large 82 Ounce

ITEM NO.	COLOR
5281 50051	White
5281 46331	Yellow
5281 50071	Orange
5281 46321	Red
5281 50011	Pink
5281 50081	Purple
5281 65011	Blue
5281 04511	Lime
5281 46301	Green
5281 04881	Brown
5281 04491	Gray



▶ 12 PER CASE.

EACH	
1-11	12+
\$4.95	\$3.95

▶ 12 PER CASE.

EACH	
1-11	12+
\$5.95	\$4.95

▶ 12 PER CASE.

EACH	
1-11	12+
\$6.95	\$5.95

Transparent Polycarbonate Scoops



- Constructed of rustproof, durable molded plastic.
- Retains look and performance, even after multiple washings.

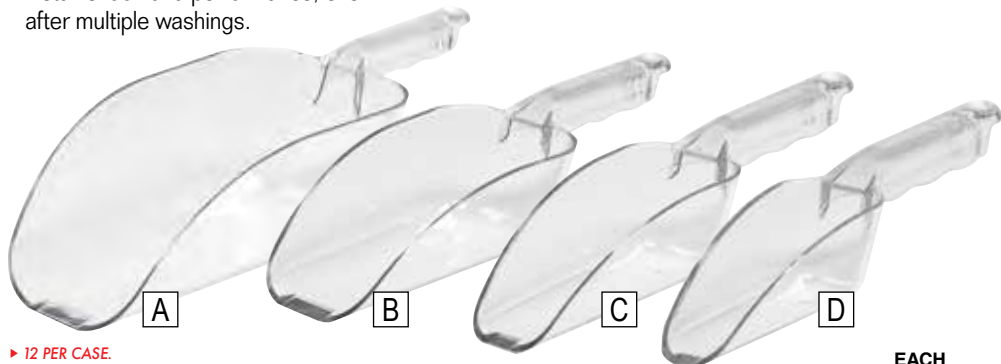

▶ 12 PER CASE.

ITEM NO.	PRODUCT	EACH	
		1-11	12+
2432 96571	A. 64 oz. Scoop	\$12.95	\$11.95
2432 08741	B. 24 oz. Scoop	7.95	6.95
2432 68101	C. 12 oz. Scoop	6.95	5.95
2432 97111	D. 6 oz. Scoop	5.95	4.95

Colored Plastic Mega Scoops



- Made from FDA-compliant materials.
- One-piece molded polypropylene.
- Capacity: Holds up to 128 ounces (1 gallon).
- Chemical-resistant.
- Can be sterilized.



Able to store upright or flat.

Measure lines embossed inside scoop.

ITEM NO.	COLOR
5281 6551	Green
5281 6552	Blue
5281 6553	Red
5281 03281	Yellow
5281 6550	White

▶ 12 PER CASE.

EACH	
1-11	12+
\$12.95	\$10.95

Vikan® Colored Plastic Bowl Scoops

- One-piece molded polypropylene with no seams or cracks to encourage bacterial growth.
- Pour spout design with raised handle and thumb grip.
- Measured graduation marks.
- Made from FDA compliant materials.



Small, 32 Ounces 7-1/4 inches x 3-1/4 inches

ITEM NO.	COLOR
5281 01371	White
5281 01381	Yellow
5281 04401	Orange
5281 01361	Red
5281 04471	Pink
5281 01901	Purple
5281 01351	Blue
5281 01321	Green

▶ 12 PER CASE.

EACH	
1-11	12+
\$13.95	\$12.95

Large, 64 Ounces 7-1/4 inches x 4-3/4 inches

ITEM NO.	COLOR
5281 01301	White
5281 01311	Yellow
5281 01291	Red
5281 01281	Blue
5281 01271	Green

▶ 12 PER CASE.

EACH	
1-11	12+
\$14.95	\$13.95

Stainless Steel Hand Scrapers

- Polypropylene handle with stainless steel blade.
- Made of FDA compliant materials, safe for food contact.
- The beveled blade is perfect to loosen and remove stubborn debris from smooth surfaces.
- Ridged blade and ergonomic handle stand up to repeated heavy use.

A. 1-1/2-Inch Blade

1-1/2 inches x 8-9/10 inches

ITEM NO.	COLOR
5281 03071	White
5281 02761	Yellow
5281 03051	Orange
5281 03081	Red
5281 03111	Pink
5281 03041	Purple
5281 03091	Blue
5281 04201	Lime
5281 03101	Green
5281 04211	Brown
5281 04111	Gray
5281 03031	Black

▶ 12 PER CASE.

EACH	
1-11	12+
\$8.95	\$7.95

B. 3-Inch Blade

3 inches x 8-9/10 inches

ITEM NO.	COLOR
5281 02981	White
5281 02971	Yellow
5281 02961	Orange
5281 02991	Red
5281 03021	Pink
5281 02951	Purple
5281 03001	Blue
5281 04051	Lime
5281 03011	Green
5281 04091	Brown
5281 04001	Gray
5281 02941	Black

▶ 12 PER CASE.

EACH	
1-11	12+
\$9.95	\$8.95



A. 3-Inch Scraper

3 inches x 7-4/5 inches

ITEM NO.	COLOR
5281 69351	White
5281 04911	Yellow
5281 96171	Orange
5281 96141	Red
5281 03881	Pink
5281 96181	Purple
5281 96131	Blue
5281 04861	Lime
5281 96121	Green
5281 04921	Brown
5281 03821	Gray
5281 00161	Black

▶ 12 PER CASE.

EACH	
1-11	12+
\$5.95	\$4.95

B. 4-Inch Scraper

4-1/4 inches x 9-1/5 inches

ITEM NO.	COLOR
5281 96251	White
5281 10041	Yellow
5281 96271	Orange
5281 10031	Red
5281 03981	Pink
5281 96281	Purple
5281 96231	Blue
5281 04901	Lime
5281 10011	Green
5281 04891	Brown
5281 03901	Gray
5281 96291	Black

▶ 12 PER CASE.

EACH	
1-11	12+
\$6.95	\$5.95



Color-Coded Plastic Scrapers

- One-piece molded polypropylene with no seams or cracks to encourage bacterial growth.
- Supports food safety material handling, cleaning and sanitation programs that are aimed at preventing cross-contamination.
- Tapered handle and thumb indentation to ensure a strong grip.
- Narrow scraping blade allows the ability to access tight spaces.
- Chemical, rust and corrosion-resistant.
- Will not scratch metal surfaces.
- Made from FDA compliant materials.



Metal Detectable Hand Scoops

- No seams or cracks to encourage bacterial growth.
- Available in two sizes:
32 ounce: 11-1/2 inches x 4-1/2 inches x 3 inches.
82 ounce: 15 inches x 6 inches x 3-1/2 inches.

32 Ounces

ITEM NO.	COLOR
5281 02351	Green
5281 02361	Blue
5281 02371	Red
5281 02381	Gray

▶ 6 PER CASE.

EACH	
1-5	6+
\$23.95	\$22.95

82 Ounces

ITEM NO.	COLOR
5281 02401	Green
5281 02411	Blue
5281 02421	Red
5281 02431	Gray

▶ 6 PER CASE.

EACH	
1-5	6+
\$33.95	\$31.95

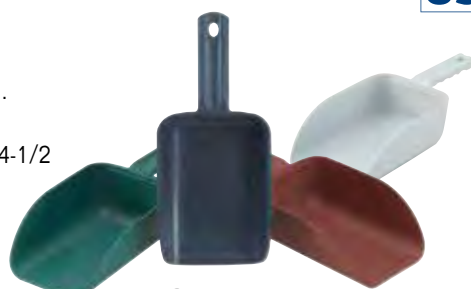

Metal Detectable Hand Scrapers

- No seams or cracks to encourage bacterial growth.
- Available in two sizes:
Small: 3 inches x 8 inches.
Large: 4-2/5 inches x 9-7/10 inches.

Small

ITEM NO.	COLOR
5281 02251	Green
5281 02261	Blue
5281 02271	Red
5281 02281	Gray

▶ 12 PER CASE.

EACH	
1-11	12+
\$9.95	\$8.95

Large

ITEM NO.	COLOR
5281 02301	Green
5281 02311	Blue
5281 02321	Red
5281 02331	Gray

▶ 12 PER CASE.

EACH	
1-11	12+
\$12.95	\$11.95



Vikan® Handle-Mounted Stainless Steel Scraper

Threaded grip enables any Vikan color-coded handle to be screwed into the grips, which allows cleaning of difficult to reach areas.

- Slightly rounded blade corners prevent damage to the surface being cleaned and operator injury.
- Suitable for removing stubborn debris.



A. 2-Inch Blade 2 inches x 8 inches

ITEM NO.	COLOR
H710 00231	White
H710 00221	Yellow
H710 00191	Orange
H710 00241	Red
H710 00181	Purple
H710 00211	Blue
H710 00201	Green
H710 00171	Black

▶ 12 PER CASE.

EACH

1-11	12+
\$16.95	\$15.95

B. 4-Inch Blade 4 inches x 8 inches

ITEM NO.	COLOR
H710 00131	White
H710 00261	Yellow
H710 00271	Orange
H710 00391	Red
H710 00141	Blue
H710 00151	Green

▶ 12 PER CASE.

EACH

1-11	12+
\$20.95	\$19.95



NOTE: Can be used with Vikan® European-thread handle, sold separately. SEE BELOW.



Vikan® Nylon Scraper with Threaded Handle

The nylon blade can be used on sensitive surfaces to avoid scratches on equipment and sensitive conveyor belts.

- A good alternative to a stainless steel blade
- Suitable for loosening stubborn dirt like pastry, chocolate, burnt on food, etc. on smooth surfaces.
- The hard blade can withstand hot surfaces when used at intervals of max. 2 minutes at a time.
- 3-9/10 inches W x 8 inches L x 1-3/10 inches D.

NOTE: Can be used with Vikan® European-thread handle, sold separately. SEE BELOW.



ITEM NO.	COLOR
5281 03661	White
5281 03671	Yellow
5281 03641	Red
5281 03631	Blue
5281 03621	Green

▶ 12 PER CASE.

EACH

1-11	12+
\$13.95	\$12.95



Vikan® Ultra Hygiene Poly Handles

- Made of food-grade polypropylene.
- Safe alternative to fiberglass handles.
- Easy to clean rounded grip handles.
- Hygienic smooth surface, sealed to prevent bacterial growth.
- Larger diameter ergonomic handle shape reduces worker fatigue.



Hygienic design with smooth surface, sealed to prevent bacterial growth.



Euro Thread

51-Inch Handle

ITEM NO.	COLOR
5281 86051	White
5281 96061	Yellow
5281 86071	Orange
5281 16041	Red
5281 96011	Pink
5281 96081	Purple
5281 86031	Blue
5281 86021	Green
5281 96091	Black

▶ 10 PER CASE.

EACH

1-9	10+
\$28.95	\$27.95

59-Inch Handle

ITEM NO.	COLOR
5281 96301	White
5281 96321	Yellow
5281 86271	Orange
5281 16241	Red
5281 96211	Pink
5281 86281	Purple
5281 16231	Blue
5281 03351	Lime
5281 86221	Green
H710 00991	Brown
5281 04291	Gray
5281 96311	Black

Dough Cutter

- Stain-free, high-carbon steel with slip-resistant polypropylene handle.
- Withstands high and low temperatures.



▶ 6 PER BOX.

ITEM NO.	PRODUCT	1-5	6+
5816 01961	6" x 3" Dough Cutter	\$10.95	\$9.95

Tramontina Dough Cutter/Scraper

Textured white polypropylene handle provide slip-resistant grip.

- Dishwasher safe.
- Stain-free, high-carbon chrome molybdenum steel.



ITEM NO.	PRODUCT	EACH
3450 92161	6" x 3" Dough Cutter/Scraper	\$14.95

Vikan® Flat Sided Pails

Optional stainless steel mounting bracket allows the pail to be stored off the ground and even upside down against a wall to allow the pail to drain and dry.

- Polypropylene pail is designed with one side flat so the pail can be stored flush against a wall.
- Raised bottom for added stability and a wide spout to prevent spilling and splashing while pouring.
- Handle constructed of non-rusting stainless steel.
- Optional snap-on lid to keep pail contents secure.
- Available in 1-1/2, 3 and 5 gallon sizes.
- 5-gallon pail has added side handles and comfort grip.



Flat-sided pail is designed to hang upside down against a wall to allow pail to drain and dry.

Stainless Steel Mounting Bracket



ITEM NO.	PRODUCT
5281 16201	Optional Bracket
EACH	
\$51.95	



A. 1-1/2-Gallon Pails 1-1/2-Gallon Lids

ITEM NO.	COLOR	ITEM NO.	COLOR
5281 02071	White	5281 02241	White
5281 02081	Yellow	5281 02291	Yellow
5281 02091	Orange	5281 02341	Orange
H710 00831	Red	5281 03841	Red
5281 02051	Pink	5281 02141	Pink
5281 00091	Purple	5281 03851	Purple
5281 02601	Blue	5281 03831	Blue
5281 03801	Lime	5281 03891	Lime
5281 01231	Green	5281 02191	Green
5281 03691	Brown	5281 03871	Brown
5281 03811	Gray	5281 03911	Gray
5281 01541	Black	5281 03861	Black

▶ 12 PER CASE.

▶ 12 PER CASE.

EACH	
1-11	12+
\$24.95	\$23.95

EACH	
1-11	12+
\$7.95	\$6.95

B. 3-Gallon Pails 3-Gallon Lids

ITEM NO.	COLOR	ITEM NO.	COLOR
5281 68651	White	5281 68751	White
5281 68661	Yellow	5281 68761	Yellow
5281 68671	Orange	5281 68771	Orange
5281 68641	Red	5281 68741	Red
5281 03231	Pink	5281 03711	Pink
5281 68701	Purple	5281 68801	Purple
5281 68631	Blue	5281 68731	Blue
5281 03301	Lime	5281 03681	Lime
5281 68621	Green	5281 68721	Green
5281 03241	Brown	5281 03701	Brown
5281 03251	Gray	5281 03651	Gray
5281 68681	Black	5281 68791	Black

▶ 5 PER CASE.

▶ 5 PER CASE.

EACH	
1-4	5+
\$28.95	\$27.95

EACH	
1-4	5+
\$14.95	\$13.95

C. 5-Gallon Pails 5-Gallon Lids

ITEM NO.	COLOR	ITEM NO.	COLOR
H710 00381	White	H710 00361	White
H710 00321	Yellow	H710 00371	Yellow
H710 00311	Red	H710 00351	Red
5281 01241	Blue	H710 00341	Blue
H710 00301	Green	H710 00331	Green

▶ 5 PER CASE.

▶ 5 PER CASE.

EACH	
1-4	5+
\$46.95	\$45.95

EACH	
1-4	5+
\$20.95	\$19.95

NOTE: Optional lid available for all size pails, sold separately.



5-gallon pail has side handles and comfort grip on handle.



No-drip spout and bottom handle are designed for easy pouring and dumping.



Measurements on inside

5-Gallon Food-Approved Plastic Bucket

- Lid available in white only and has tear-tabs for easier openings.
- 90 mil heavy-duty polyethylene.
- FDA compliant for contact with food products.



Buckets have child warning labels.

ITEM NO.	COLOR		
2316 00231	White		
2316 00221	Red		
2316 00201	Blue		
2316 00211	Green		
2316 00241	Yellow		
2316 00191	Black		
		▶ 12 PER CASE.	
		EACH	
		1-11	12+
		\$15.95	\$14.95

ITEM NO.	PRODUCT	1-11	12+
2316 00181	Lid, White.	\$4.95	\$3.95



2 to 5 Gallon Container Opener

Three tools in one!

1. Cutterhead cuts slotted covers safely.
 2. Built in leverage handle easily opens any 3- to 5-gallon plastic lid.
 3. Quickly reseals ANY type of lid.
- Molded of light-weight aluminum.

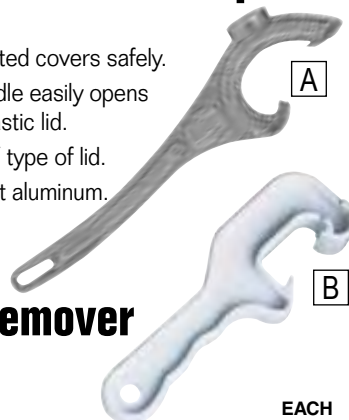

Pail Cover Remover

- Length: 12 inches.

ITEM NO.	PRODUCT	EACH
6604 00261	A. Aluminum 2- to 5 Gallon	\$43.95
3247 24321	B. Plastic 5 Gallon	16.95



19-Quart Double Pail

- Gray plastic pail separates cleaning solution and rinse water for an easy-to-use cleaning system.
- Capacity: 19 quarts (4-3/4 gallons).



Pail has quart and liter measurement markings inside.



Conveniently carry supplies.



Fits most roller mops.



Easy-to-pour spout.

ITEM NO.	PRODUCT	DIMENSIONS	EACH
1770 26281	Double Pail	18" x 14-1/2" x 10"	\$42.95

6-Gallon Mop Pail with Lid

- Ideal for carrying soiled pads and cloths.
- Rugged poly carrying handle.
- Rectangular shape.
- Capacity: 6 gallons (24 quarts).
- Color: gray.



NOTE: Ideal for use with 18-inch wet mop pads, sold separately.

► SEE PAGES 116 - 121
For Mops and Accessories



ITEM NO.	PRODUCT	DIMENSIONS	EACH	
			1-11	12+
6387 19231	6-Gallon Mop Pail	20-1/2" x 10-1/2" x 11-1/4"	\$45.95	\$44.95

Round Poly Pails

Perfect for any job.



- Convenient pouring spout molded in the side.
- Plastic construction resists acid, alkaline, chemicals and cleaning compounds.
- Insulated looped bail handle.

10 Quart

ITEM NO.	COLOR	► 12 PER CASE. EACH	
		1-11	12+
2760 14891	Red		
2760 14861	Gray	\$16.95	\$15.95
2760 99291	White		

14 Quart

ITEM NO.	COLOR	► 12 PER CASE. EACH	
		1-11	12+
2760 14951	Red		
2760 14921	Gray	\$23.85	\$22.85
2760 14981	White		



► SEE PAGE 235

FOR STAINLESS STEEL PAILS



Color-Coded Jugs

- Color-coded jugs decrease the risk of chemical accidents and cross-contamination.
- Eliminate microbial contamination by using color-coded containers.
- The use of color-coding: eliminates cross contamination, eliminates chemical accidents, eliminates language barriers.

A. 2-1/2 Gallon

ITEM NO.	COLOR
H414 5025	Dark Blue
H414 5026	Orange
H414 5027	Pink
H414 5028	Red
H414 5029	Tan
H414 5030	White
H414 5031	Yellow

EACH
\$49.95



B. 5 Gallon

ITEM NO.	COLOR
H414 00141	Dark Blue
H414 00121	Orange
H414 00161	Pink
H414 00101	Red
H414 00151	Tan
H414 00111	White
H414 00131	Yellow

EACH
\$89.95



Dome Lid

- For use on 44- and 55-gallon round brute drums.
- Heavy-duty plastic construction resists denting, bending or cracking.
- Hinged door swings shut automatically to trap odors.



NOTE: Pallet prices available. CALL FOR DETAILS.



ITEM NO.	SIZE	COLOR	EACH
1770 7753	44 Gallon	Red	\$149.95
1770 4788	44 Gallon	Gray	149.95
1770 0008	55 Gallon	Red	169.95
1770 4790	55 Gallon	Gray	169.95

Funnel Top Lid

- Allows hands free, no touch disposal.
- Crack-resistant plastic withstands indoor and outdoor use.
- Fits 32-gallon round drums only.



▶ 6 PER CASE.

ITEM NO.	SIZE	COLOR	EACH	
			1-5	6+
1770 79871	32 Gallon	Gray	\$60.95	\$59.95

Imprinted Round Containers

Imprinted for clarity and easy identification.

- Each style is Hot Stamp imprinted with black 2-inch lettering.
- All drums are imprinted on 2 sides, in Spanish and English.
- Molded-in notches for easy dolly attachment.
- NSF 2 approved for food contact and cleanability.
- BPA free.



NOTE: Custom Imprinted containers available by special order. CALL FOR DETAILS.

20-Gallon Drums

ITEM NO.	COLOR	IMPRINT
6387 13281	Gray	INEDIBLE

▶ 6 PER CASE.

EACH	
1-5	6+
\$28.05	\$27.05

32-Gallon Drums

ITEM NO.	COLOR	IMPRINT
6387 13121	White	EDIBLE
6387 12671	Gray	INEDIBLE
6387 12661	Red	INEDIBLE
6387 13081	Yellow	INEDIBLE
6387 13091	Blue	TRASH
6387 12691	Gray	TRASH
6387 13071	Red	CONDEMNED
6387 12681	Yellow	CONDEMNED

▶ 4 PER CASE.

EACH	
1-3	4+
\$36.75	\$35.75

44-Gallon Drums

ITEM NO.	COLOR	IMPRINT
6387 13131	White	EDIBLE
6387 13231	Gray	INEDIBLE
6387 13271	Red	INEDIBLE
6387 13201	Yellow	INEDIBLE
6387 13211	Blue	TRASH
6387 13221	Gray	TRASH
6387 13241	Yellow	TRASH
6387 13261	Yellow	CONDEMNED

▶ 3 PER CASE.

EACH	
1-2	3+
\$46.15	\$45.15



▶ SEE PAGE 257 and ABOVE For Lids, Sold Separately



Sturdy Comfort Curve™ eases lifting and maneuverability.



Double reinforced drag skids prolong life. Helper handles on base for controlled tipping or overhead lifting.



Snap down reinforced lid with press and pull release stays on and is easy to remove.

Round Container Lids

- Snap down reinforced lid with press and pull release stays on and is easy to remove.
- Rounded edges and textured surface resists abrasions and scuffs.
- Raised inner circle matches container base for stacking and organization.



▶ 6 PER CASE.

EACH

1-5 6+
\$8.35 \$7.35

10-Gallon Lids

ITEM NO.	COLOR
6387 14881	Black
6387 13141	Blue
6387 09471	Dark Green
6387 09481	Gray
6387 09441	Red
6387 34101	Yellow
6387 06601	White
6387 11591	Orange
6387 14871	Purple

20-Gallon Lids

ITEM NO.	COLOR
6387 14801	Black
6387 19971	Blue
6387 34351	Dark Green
6387 34361	Gray
6387 34331	Red
6387 34341	Yellow
6387 32511	White
6387 05801	Orange
6387 14791	Purple

▶ 6 PER CASE.

EACH

1-5 6+
\$9.35 \$8.35

32-Gallon Lids

ITEM NO.	COLOR
6387 14831	Black
6387 32491	Blue
6387 32481	Dark Green
6387 32501	Gray
6387 32471	Red
6387 32461	Yellow
6387 32451	White
6387 33241	Orange
6387 13381	Purple

▶ 6 PER CASE.

EACH

1-5 6+
\$12.55 \$11.55

44-Gallon Lids

ITEM NO.	COLOR
6387 14861	Black
6387 32841	Blue
6387 32831	Dark Green
6387 32851	Gray
6387 32821	Red
6387 32811	Yellow
6387 32801	White
6387 32861	Orange
6387 14851	Purple

▶ 6 PER CASE.

EACH

1-5 6+
\$21.95 \$20.95

55-Gallon Lids

ITEM NO.	COLOR
6387 15841	Black
6387 09461	Blue
6387 56091	Dark Green
6387 56231	Gray
6387 09451	Red
6387 56061	Yellow
6387 06561	White
6387 15851	Purple

▶ 6 PER CASE.

EACH

1-5 6+
\$28.45 \$27.45

Round Food-Approved Drums

- Constructed with the highest quality material plus a UV inhibitor ensures long life in even the most extreme commercial environments.
- Anti-jam nesting when drums are not in use saves valuable storage space.
- Easy-to-clean, seamless molded plastic.
- Guaranteed to never fade, warp, crack or crush.
- NSF 2 and 21 approved.

Tight-fitting lids allow drums to be stacked when full.



10-Gallon Drums

ITEM NO.	COLOR
6387 14811	Black
6387 34111	Blue
6387 09391	Dark Green
6387 09431	Gray
6387 09371	Red
6387 09541	Yellow
6387 03521	White
6387 10501	Orange
6387 14891	Purple

▶ 6 PER CASE.

EACH

1-5 6+
\$18.85 \$17.85

20-Gallon Drums

ITEM NO.	COLOR
6387 14771	Black
6387 32361	Blue
6387 19981	Dark Green
6387 34321	Gray
6387 19991	Red
6387 34311	Yellow
6387 34301	White
6387 20171	Orange
6387 13551	Purple

▶ 6 PER CASE.

EACH

1-5 6+
\$27.25 \$26.25

32-Gallon Drums

ITEM NO.	COLOR
6387 14821	Black
6387 32331	Blue
6387 32091	Dark Green
6387 32341	Gray
6387 32321	Red
6387 32311	Yellow
6387 32301	White
6387 32391	Orange
6387 13371	Purple

▶ 4 PER CASE.

EACH

1-3 4+
\$35.65 \$34.65

44-Gallon Drums

ITEM NO.	COLOR
6387 14761	Black
6387 32741	Blue
6387 32731	Dark Green
6387 32761	Gray
6387 32721	Red
6387 32711	Yellow
6387 32701	White
6387 32791	Orange
6387 14841	Purple

▶ 3 PER CASE.

EACH

1-2 3+
\$53.65 \$52.65

55-Gallon Drums

ITEM NO.	COLOR
6387 15221	Black
6387 09411	Blue
6387 55111	Dark Green
6387 55231	Gray
6387 09401	Red
6387 09421	Yellow
6387 05481	White
6387 05221	Purple

▶ 2 PER CASE.

EACH

1 2+
\$81.45 \$80.45

Atlas Containers

Commercial-grade, large-capacity rugged containers are built to last

- Advanced Rotational Molding manufacturing process provides extreme durability, superior impact-resistance and long life.
- Patented Rugged Rim® construction – exclusively from Toter.
- Single-piece design, with non-slip handles molded into the container, so they won't rip or tear off during use.
- Heavy-duty construction protects against wear.
- Can be used for a variety of applications including trash, recycling, yard waste and animal feed, indoor or outdoor use.
- Drum color: light gray. • Lid color: black.



Scan this QR Code with your mobile device to watch a video about Advanced Rotational Molding.

NOTE:
Additional colors available.
CALL FOR DETAILS.

Toter®

MADE IN USA



Factory installed dolly adaptor works with universal caster dollies.



Molded non-slip handles.



Fluted inner walls make removal of plastic bags or liners effortless.

Custom Imprinting Available

Graphics won't peel or scratch off with use!



Hot Stamp



Mold-in graphics

CALL 800-456-5624 for more information or to place your order. Minimums apply.

ITEM NO.	PRODUCT	CAPACITY	DIMENSIONS	EACH
6548 00401	Atlas Container	32 Gallon	22-3/4" dia. x 27"	\$59.95
6548 0047	Atlas Container	44 Gallon	24-3/4" dia. x 31-1/4"	69.95
6548 00021	Flat Lid	32 Gallon	23-1/2" dia. x 1-3/4"	54.95
6548 00031	Flat Lid	44 Gallon	25-1/2" dia. x 1-3/4"	69.95

44-Gallon Drum with Venting Channels

Removing liners is now easier than ever!

- Innovative venting channels make lifting out liners up to 50% easier, improving productivity and reducing the risk of injury.
- Integrated cinches secure the liner, allowing for efficient knot free liner changes. Tested to 20,000 cycles.
- NSF 2 and 21 approved.

MADE IN USA



Optional self-draining lid.



Four liner cinches allow for efficient knot free liner changes.



Contoured base handles improve grip and ergonomics, reducing strain and improving efficiency when emptying containers



Four patent-pending venting channels dramatically reduce the force required to remove a full can liner.

ITEM NO.	PRODUCT	EACH
1770 26611	Drum, Gray	\$80.95
1770 43611	Drum, Black	80.95
1770 43621	Drum, Blue	80.95
1770 43641	Drum, Yellow	80.95
1770 26601	Self-Draining Lid, Black	20.95

NOTE: Additional colors available.
CALL FOR DETAILS.

Caddy Bag

Turn your drum and dolly into a mobile cleaning station.

- 7-pockets and 5-elastic pouches designed to hold brushes, sponges, chemicals and other cleaning utensils (sold separately).
- Buckle and straps attach caddy to handles, while strong Velcro® affixes the bottom of caddy to brute.
- Caddy fits 32 and 44 gallon capacity brutes.



▶ 6 PER CASE.

ITEM NO.	PRODUCT	SIZE	EACH	
			1-5	6+
1770 77361	Caddy Bag	20" x 20-1/2"	\$70.95	\$59.95

MegaSteady Drum Dolly

- Five wheel, pentagon shaped dolly for super steady rolling.
- Heavy-duty 3-inch wheels and swivel casters allow easy mobility.
- Holds 20-55-gallon sizes of round drums.
- Capacity: 625 pounds.

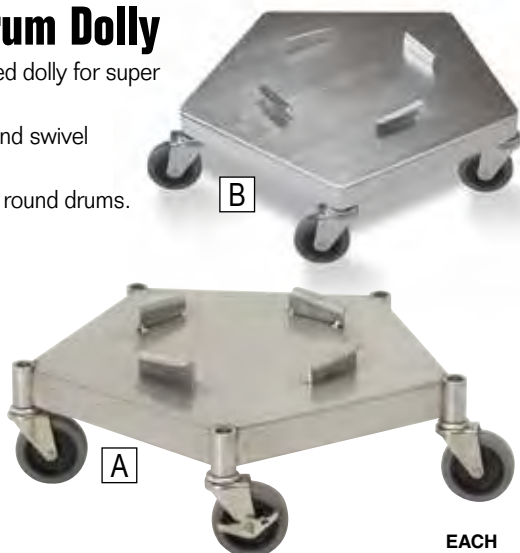

ITEM NO.	PRODUCT	EACH
2510 0319	A. Aluminum, MegaSteady Drum Dolly	\$66.05
3013 0025	B. Stainless Steel Drum Dolly	268.55

Universal Dolly

Makes moving drums around the plant easy!

- Universal dolly fits all 10- through 55-gallon drums.
- Includes heavy-duty swivel casters to enhance mobility.
- Dimensions: 24-3/4 inches W x 7-1/8 inches H.
- Load capacity: 500 pounds.
- Color: black.



ITEM NO.	PRODUCT	EACH
1770 77581	Round Universal Dolly	\$171.95
3414 0004	Replacement 3" Swivel Casters	14.95

Tandem Drum Dolly



- Carries two drums at one time.
- Heavy-duty 8 wheels and swivel casters allow easy mobility.
- Hinge in the center allows one side to fold up for easy storage or for transporting only one drum.
- Fits 20-, 32-, 44- and 55-gallon round drums.



NOTE: Drums sold separately.

ITEM NO.	PRODUCT	CAPACITY	EACH
1770 3538	Tandem Dolly	200 lb.	\$234.00
3414 1739	Replacement 2 Wheels and Axle		42.95
3414 1112	Replacement 4" Non-Marking Plate Swivel Caster		29.95

Round Twist-On Dolly



- May be permanently attached to drum.
- Round twist-on dolly fits 20-, 32-, 44- and 55-gallon round drums.
- Dolly height: 5 inches.
- Riveted casters.
- Wheels are NOT replaceable.



▶ 2 PER CASE.

ITEM NO.	PRODUCT	CAPACITY	EACH	
			1	2+
6387 33171	Round Twist-On Dolly	250 lb.	\$46.45	\$45.45

Stainless Steel Drum Backsplash



- 18-gauge stainless steel.
- Fits 32-, 44- and 55-gallon round trash cans.
- Wrap around design keeps floors and walls clean.
- Nesting design allows room for inside can liner.
- Dimensions: 18 inches H x 38 inches W.

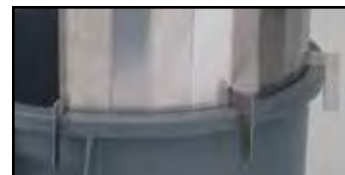

Five stainless steel tabs hold backsplash securely in place.



ITEM NO.	PRODUCT	F.O.B. FACTORY EACH
2510 18381	Stainless Steel Backsplash	\$112.95

Square Food-Approved Drums

All the features of our round drums, plus space efficient square brutes provide 14% more capacity.

- Gray and White are USDA Meat and Poultry Equipment Group Listed and assist in complying with HACCP guidelines.
- Rounded corners and smooth contours are easy to clean.
- Certified to NSF Std. #2 (gray and white) and Std. #21.
- Nesting handles allow secure fit for side-by-side use.



28-Gallon Drums

▶ 6 PER CASE.

ITEM NO.	COLOR	DIMENSIONS	EACH	
			1-5	6+
1770 89541	White	21-1/2" x 21-1/2" x 22-3/5"	\$57.95	\$56.95
1770 08261	Gray	21-1/2" x 21-1/2" x 22-3/5"	78.95	75.95

40-Gallon Drums

▶ 4 PER CASE.

ITEM NO.	COLOR	DIMENSIONS	EACH	
			1-3	4+
1770 89501	White	23-1/2" x 23-1/2" x 28-4/5"	\$90.95	\$89.95
1770 09161	Gray	23-1/2" x 23-1/2" x 28-4/5"	90.95	89.95

28-Gallon Lids

▶ 6 PER CASE.

ITEM NO.	COLOR	DIMENSIONS	EACH	
			1-5	6+
1770 89561	White	22-1/2" x 22-1/2" x 2"	\$25.95	\$24.95
1770 89551	Gray	22-1/2" x 22-1/2" x 2"	25.95	24.95

40-Gallon Lids

▶ 4 PER CASE.

ITEM NO.	COLOR	DIMENSIONS	EACH	
			1-3	4+
1770 35391	White	24" x 24" x 2"	\$27.95	\$26.95
1770 79801	Gray	24" x 24" x 2"	28.95	27.95



Square Twist-On Dolly

- All plastic, professional-grade construction resists rust, chipping and denting.
- Heavy-duty wheels with swivel capabilities provide for ease of mobility.
- Square twist-on dolly fits both the 28- and 40-gallon square drums.
- May be permanently attached to drum.
- 17-1/5 inches L x 17-1/5 inches W x 6-1/5 inches H.
- Capacity: 300 pounds.



▶ 2 PER CASE.

ITEM NO.	PRODUCT	EACH	
		1	2+
1770 01201	Twist-On Dolly	\$120.95	\$117.95
ITEM NO.	PRODUCT	EACH	
3414 5234	3" Replacement Casters	\$11.55	

Rollout Containers

The largest portable trash containers we sell!

- Rotationally molded, one-piece construction for superior durability.
- Ground-hugging base is designed for stability.
- Lifter bar on (65- and 95-gallon models) is compatible with semi-automated lifting systems.
- Non-slip handle is easier to grip and foot tilter is designed to maneuver heavy loads.
- 50 gallon: 8-inch rubber tread wheels; 65 and 90 gallon: 10-inch rubber tread wheels, both with steel axle to easily roll over rough surfaces and are inset to avoid damage to walls and doors.
- Stackable lid design.



ITEM NO.	PRODUCT	COLOR	DIMENSIONS	EACH
1770 92551	50 Gallon	Gray	.28-1/2" x 23-2/5" x 36-1/2"	\$234.95
1770 95291	50 Gallon	Blue, Recycle	.28-1/2" x 23-2/5" x 36-1/2"	189.00
1770 9260	65 Gallon	Gray	.32-3/10" x 25-1/4" x 41-4/5"	249.00
1770 9127	95 Gallon	Blue	.32-2/5" x 27-3/10" x 45-3/5"	300.00



Coreless Can Liners on Rolls

Heavy-Duty Industrial Liners

Coreless rolls packed in an easy-to-use dispenser case.

- Strong, low-density bags are ideal for wet trash and heavy loads.
- Black color bags hide unsightly garbage.
- Six gussets for added strength.



ITEM NO.	CAPACITY	SIZE	MIL	BAGS/CASE	CASE
7600 4265	20-30 Gallon	30" x 36"	0.9	200	\$41.85
7600 4270	32 Gallon	33" x 39"	1.3	100	36.95
7600 4275	44 Gallon	40" x 46"	1.3	100	51.45
7600 4281	56 Gallon	42" x 47"	1.3	100	55.25
7600 4293	60 Gallon	38" x 58"	1.3	100	60.95

2.5 Mil Steel Blue Super Heavy-Duty Can Liner

The toughest liner you can buy at any price!

- Made from super hexene resin.
- Perforated, coreless roll.
- Gauge: 2.5 mil.
- Color: dark blue.



No-burst bag stretches where other bags tend to break!



ITEM NO.	CAPACITY	SIZE	BAGS/CASE	CASE
6160 6440	33 Gallon	33" x 40"	100	\$78.95
6160 6448	45 Gallon	40" x 48"	50	57.95
6160 4860	60 Gallon	38" x 58"	50	66.15

DrawTape Can Liners

Simply pull drawtape to close, easy to lift and carry.

- Maximum efficiency — eliminates bag tie-offs.
- Made from premium LLDPE resins for superior puncture and tear resistance.
- Tough seamless bottom for extra strength.
- Interleaf coreless rolls.



ITEM NO.	CAPACITY	SIZE	MIL	COLOR	BAGS/CASE	CASE
2266 2638	23 Gallon	26-1/2" x 38"	1.0	White	200	\$66.45
2266 2840	23 Gallon	26-1/2" x 38"	1.2	White	200	85.95
2266 3338	32 Gallon	33" x 38"	1.0	Clear	200	79.95
2266 3747	44 Gallon	37" x 45"	1.4	Black	100	71.65
2266 4044	55 Gallon	40-1/2" x 45"	1.4	Black	100	78.35

High-Density Economy Liners

Coreless rolls packed in an easy-to-use dispenser case.

- Perforated coreless rolls are time saving, cost efficient and easy to dispense.
- Clear, puncture resistant bags are perfect for light loads.
- Star-seal bottom.



ITEM NO.	CAPACITY	SIZE	GAUGE	BAGS/CASE	CASE
7500 4857	12-16 Gallon	23" x 33"	5 Microns	1,000	\$34.95
7500 4862	20-30 Gallon	30" x 36"	13 Microns	250	31.95
7500 4860	20-30 Gallon	30" x 36"	8 Microns	500	38.95
7500 4869	33 Gallon	33" x 39"	14 Microns	250	41.95
7500 4867	33 Gallon	33" x 39"	12 Microns	250	34.95
7500 4884	40-45 Gallon	40" x 46"	14 Microns	250	58.75
7500 4874	60 Gallon	38" x 57"	19 Microns	150	56.25
7500 4872	60 Gallon	38" x 57"	12 Microns	200	47.95
7500 4889	56 Gallon	42" x 47"	14 Microns	200	50.95

Heavy-Duty, Stainless Steel Knockdown Trash Liner Holder

- Fits 32- and 44-gallon liners.
- Made of 16-gauge, T304 stainless steel.
- Easy to assemble, no tools required.
- Dimensions: Upper ring: 44-1/2 inches ID; Lower ring: 37 inches ID; Height: 42 inches; Weight: 4 pounds.



Ships knocked-down.

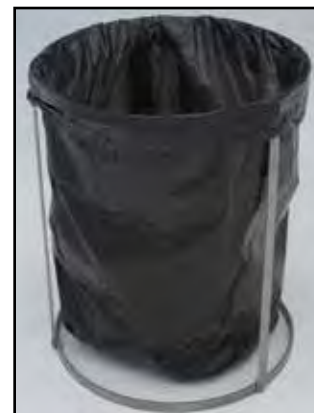

ITEM NO.	PRODUCT	EACH
2990 21061	Stainless Steel Knockdown Trash Liner Holder	\$234.25

28-Quart Waste Bins®

Classic space saving, cost efficient design.

- Easily fits underneath standard desk height.
- All-plastic construction won't dent, chip or rust.
- Rolled rims add strength and are easy to clean.
- Dimensions: 14-3/8 inches L x 10-1/4 inches W x 15 inches H.



► 12 PER CASE.

ITEM NO.	PRODUCT	COLOR	EACH	
			1-11	12+
1770 29561	Recycle Bin	Blue	\$13.95	\$12.95
1770 08481	Waste Bin	Gray	14.95	13.95

Trimline™ Waste Containers

- Integrated tabs prevent liners from slipping into container.
- Optional swing lid conceals trash while providing easy touch-free access.
- Hand grips on container bottom simplify lifting and emptying.
- Capacity: 23 gallons.
- Textured surface resists scuffs and marking.
- Smooth inner surface is easy to clean.
- Slim rectangle waste container fits neatly in narrow spaces.
- Dimensions: 20 inches L x 11 inches W x 30 inches H.



Containers

ITEM NO.	COLOR	
6387 32951	Brown	
6387 23121	Black	
6387 32931	Beige	
6387 23111	Green	
6387 14671	Blue	
6387 14441	Gray	

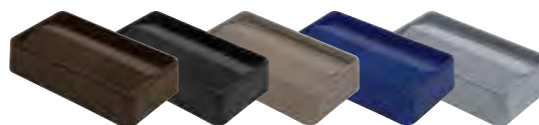

NOTE: Containers and lids sold separately.



► 4 PER CASE.

EACH	
1-3	4+
\$84.15	\$83.15

Lids

ITEM NO.	COLOR	
6387 14681	Brown	
6387 32961	Beige	
6387 14721	Beige	
6387 14691	Blue	
6387 14711	Gray	

Green lid not available.

► 4 PER CASE.

EACH	
1-3	4+
\$51.95	\$50.95

Untouchable®

Comply with HACCP with a hygienic, hands-free refuse disposal.

- Durable crack resistant plastic stands up to the toughest indoor outdoor treatment.
- Open top allows waste to be disposed of without container contact.

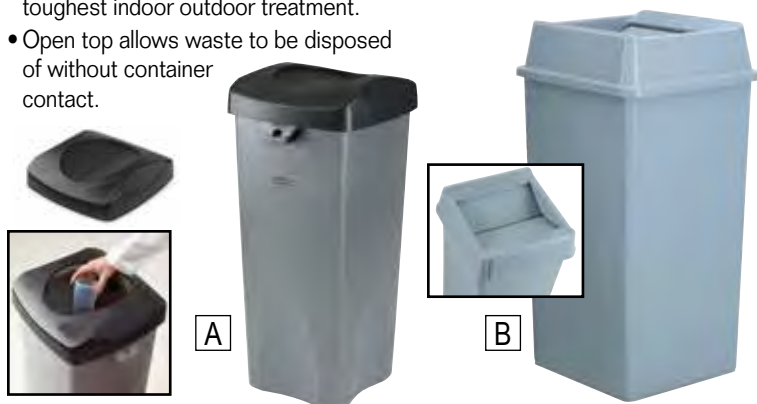

ITEM NO.	PRODUCT	COLOR	DIMENSIONS	EACH
1770 26941	A. 23-Gallon Lid	Black	14-9/10" x 14-9/10" x 4-1/2"	\$44.95
1770 69881	23 Gallon Container	Gray	14-1/2" x 14-1/2" x 28"	99.95
1770 02661	B. 50-Gallon Lid	Gray	20-1/10" x 20-1/10" x 6-1/4"	99.95
1770 39601	50 Gallon Container	Gray	19-1/2" x 19-1/2" x 27-3/4"	241.95

The Glutton®

Perfect for large crowds and high traffic areas.

- Designed to withstand extreme weather and handling.
- Hooded top provides added strength.
- Tough easy-to-clean container.
- Capacity: 56 gallons.



NOTE: Container and lid sold separately.

ITEM NO.	PRODUCT	COLOR	DIMENSIONS	EACH
1770 72561	A. 56-Gallon Container	Off-White	25-1/2" x 22-3/4" x 31-1/10"	\$269.95
1770 7653	B. Hooded top w/Doors	Red	26-3/5" x 23" x 13"	349.95
1770 7652	C. Hooded top w/Doors	Brown	26-3/5" x 23" x 13"	349.95
1770 7646	D. Hooded top w/o Doors	Red	26-3/5" x 23" x 13"	279.95

Cigarette Butt Receptacle

- Cease-Fire® design limits the flow of oxygen to safely and quickly extinguish cigarettes to reduce the risk of fire — and prevents "chimney effect".
- Covered 1-1/2-inch opening keeps rain out and discourages trash from being dropped in.
- Large, 16-quart galvanized steel liner pail removes for easy cleaning.
- Large internal neck cavity minimizes clogging.
- Dimensions: 16-1/2 inch dia. x 38-1/2 inches H.



ITEM NO.	PRODUCT	EACH
B616 0010	Cigarette Butt Receptacle	\$120.85

Dome Lid Trash Can, Brown

Rugged enough to withstand demanding temperatures and weather extremes.

- One-piece durable plastic construction features a snug-fit hinged top with gravity closure door and a bag holder for easy maintenance and neatness.
- Resists corrosion and maintains appearance year after year.
- UL rated Fire Resistant and Factory Mutual approved for fire safety.
- Under normal use with top on and lid closed, the container will restrain flames and even extinguish them.



ITEM NO.	PRODUCT	DIMENSIONS	EACH
1770 9402	15 Gallon	15-2/5" x 36-1/2"	\$249.95
1770 6094	25 Gallon	18" x 24"	329.95



Heavy-Duty Stainless Steel Receiving Desk

A versatile stainless steel desk for the workplace.

- Desk is made with three 9-inch deep storage compartments.
- 18-gauge stainless steel work surface measures 24 inches wide x 23 inches deep.
- Desk includes wall mounting brackets. Mobile stainless frame and casters sold separately.
- Optional stainless frame is constructed of 1-inch tubing with four, 5-inch swivel casters, 2 with brakes.
- Frame adds mobility and includes stainless undershelf for storage.
- Shipping Weight: 40 pounds.



Desktop locks to allow for document storage. Includes two keys.



Space saver desk includes wall mounting brackets.



Add optional legs and casters to turn unit into a convenient all-around desk.



ITEM NO.	PRODUCT	DIMENSIONS	EACH
2990 2101	Wall Mount Desk	24" x 23" x 12"	\$735.95
2990 2102	Optional Mobile Frame with Caster Set.	23" x 25" x 35-1/2"	499.95