

SATO AIR PUMP

佐藤エアポンプ



Osaka Japan



About Linear Air Pump

SATO air pump offers a full range of linear diaphragm pump that is perfectly applied to a broad application, such as waste water treatment, medical, consumer appliance and fish pond.

Linear pump system is for oil-free air, very silent operation, energy saving, low vibration and long life. All components are precisely selected from quality material around the world, for example strong permanent magnet and special diaphragms. Skilled engineers carefully design the linear system in order to work smoothly. Experienced staffs devote to ensure the excellence in production step and continuously develop to perfection. We only select the best to create brand SATO air pump representing world-class quality.

We ensure once you decide to use SATO air pump, you will fully satisfy with our commitment, quality material and perfect system. Thank you for choosing SATO air pump.



How SATO air pump Works – The Linear Concept

Simply operated by magnetic concept, alternating current (AC power) is applied to the electromagnet to generate magnetic power. The actuating rod, in the middle of two direction electromagnets, moves right and left consecutively (Fig. A and Fig B). This is called linear direction. This movement occurs from magnetic attraction and repellent forces between magnetic power of electromagnet and permanent magnet in actuating rod. Actuating rod moves at the same rate as frequency of power supply.

With two diaphragms attached at the edge on both sides of actuating rod, one diaphragm is generating air suction while the other is blowing into chamber and vice versa. The air intake, compression and air exhaust can be performed through the valves attached on casing. By the magnetic power, there is no touching part in the movement so lubrication, from oil or grease, is not necessary.

By complete working cycle, SATO air pump can generate clean and constant air flow for any application.

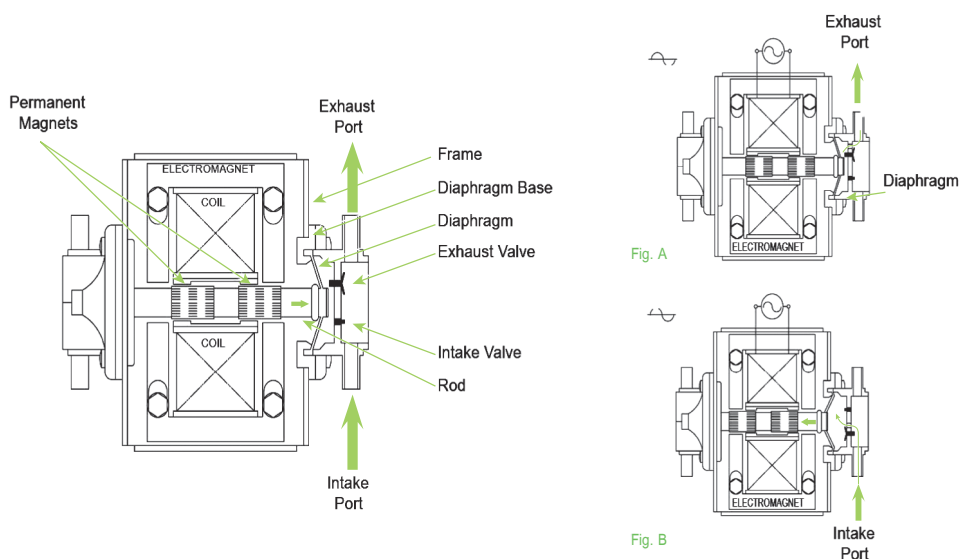

FEATURES - MADE FOR GREEN

GREEN BY RELIABILITY

With the basic structure, the moving parts consist of an actuating rod and two special synthetic rubber diaphragms. Thanks to the flexibility of special rubber, the movement of diaphragms is balanced in controllable direction. This simple construction allows long-term continuous operation.

GREEN BY CLEAN AIR BY OIL-FREE

With magnetic concept, there is neither touching nor friction between moving parts. No need of lubrication at all, plus the exhausted air is always clean.

GREEN BY HIGH EFFICIENCY

Unlike other mechanical principal, electromagnetic vibration eliminates the need for reducing friction from touching or sliding parts. With less friction, SATO air pump consumes less power but higher performance.

GREEN BY TOUGH JOB

With two electromagnets on the both sides of moving parts, it allows strong power and consistent movement but smaller size than other vibration mechanism such as piston.

GREEN BY SILENT

Thanks to flexibility of special rubber and soundproof-design, SATO air pump is working at quiet sound than ever.

GREEN BY CONSTANT FLOW

By two diaphragms moving different direction at the same time, one is suction and the other is blowing, vice versa. With this cycle in every movement of actuating rod, SATO air pump produces the constant air volume and pressure; less pulsation than other vibration mechanism such as piston.

GREEN BY SIMPLE

Besides made by quality material and good technology, SATO air pump maintenance can be easily done by modular concept which allows simply disassemble in case of broken diaphragm.

SATO air pump Applications

- Waste Water Treatment
- Aquaculture Aeration
- Fish Pond
- Gas Analyzers
- Medical Nebulizers
- Ozone Generators
- Inflatable Packaging Machines
- Solder Removal Devices
- Agriculture Aeration
- Fuel Cells
- Air Sampling
- Liquid Agitation
- Air Mattresses
- Sequential Compression (Circulation Therapy)
- Blood Cuff Monitors
- Membrane Oxygen Generators



線形空気ポンプについて

SATO空気ポンプは、幅広いアプリケーション(例えば廃物の水処置、医療、消費者向け機器や養魚池)に適用される一連の線形横隔膜ポンプを提供します。

線形ポンプ・システムでは、オイルフリーの空気、非常に静かな操作、省エネ、低い振動と長期の使用が望めます。全部品は世界中の上質の材料、例えば強い永久マグネットや特別なダイヤフラムなどから正確に選ばれています。熟練したエンジニアが、線形システムの動きを滑らかにするために、慎重に線形システムを設計しています。経験豊かなスタッフは、生産ステップにおける卓越性を確実にして、絶えず完全さを求めています。我々は、世界に通用する高品質であるブランド、SATO空気ポンプを作製するのに、最善のものだけを選んでいきます。

我々は、SATO空気ポンプを使っていただけならば、上質の材料と完全なシステムでお客様に十分に満足していただけることを責任を持って保障致します。SATO空気ポンプを選んでいただき、感謝申し上げます。

SATO空気ポンプは、どのように動くのか - 線形概念

磁気概念によって作動し、交流(AC電源)は電磁石に磁気力を発生させるために、適用されます。動かしているロッドは、2つの電磁石の中央で連続して左右に動きます。(図Aと図B)これは、線形方向と呼ばれています。この動きは、ロッドを作動させる際に、電磁石の磁気力と永久磁石の間で磁力とそれに反発する力から起こります。ロッドを作動させることは、電力供給の頻度と同じ率で動きます。

ロッドの両側に2つのダイヤフラムを取り付け、1つのダイヤフラムが部屋の中に吹き込む間、もう1枚のダイヤフラムは逆に空気を吸引しています。空気取り入れ口、圧縮及び空気排気は、ケースの上に付けられたバルブによって行われます。磁気力によって、一連の動きの中で機械に触れることがないので油またはグリースで滑らかにすることは必要ではありません。

このような完全な動きのサークルによって、SATO空気ポンプはどのようなアプリケーションでも、きれいで一定した気流を生み出すことができるのです。

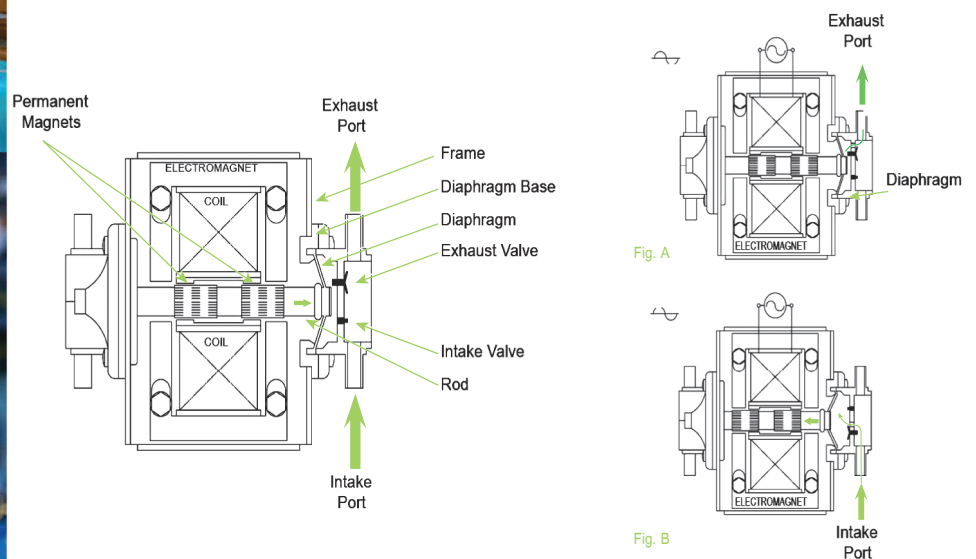

特長 ~緑の為に~

GREEN BY RELIABILITY

基本的な構造で、可動部分は作動ロッド及び2つの特別な合成ゴムのダイヤフラムから成っています。特別な柔軟性のあるゴムのおかげで、ダイヤフラムの動きは、制御可能な方向でバランスが保たれます。この単純な構造が、長期の連続操作を可能にします。

GREEN BY CLEAN AIR BY OIL-FREE

磁気概念によって、可動部分の間に生じる摩擦も触れることもありません。注油の必要がなく、また空になった空気はいつでもきれいです。

GREEN BY HIGH EFFICIENCY

他の主な機械とは異なり、電磁振動は、接触による摩擦を減らしたり部品を滑らせる必要がありません。より少ない摩擦によって、SATO空気ポンプは、より少ない力でより高いパフォーマンスを提供いたします。

GREEN BY TOUGH JOB

可動部分の両側の二つの電磁石によって、ピストンのような他の振動メカニズムより、より小さいサイズで強い力と一貫した運動を可能にします。

GREEN BY SILENT

特別なゴムと防音デザインにより、SATO空気ポンプはこれまでより静かな音に取り組んでおります。

GREEN BY CONSTANT FLOW

同時に異なる方向に動いている2つのダイヤフラムによって、1つは吸引、もう1つはその逆に吹いています。このロッドを作動させるシステムによって、SATO空気ポンプは、ピストンのような他の振動メカニズムより、より少ない波動で一定した空気ボリュームと圧力を作り出します。

GREEN BY SIMPLE

上質の材料とハイテクノロジーの他にも、SATO空気ポンプのメンテナンスは、ダイヤフラムが壊れた場合には、モジュラー概念によって簡単に速やかに行うことができます。

SATO 空気ポンプ・アプリケーション

廃物の水処置
水産養殖通気
養魚池
ガス分析器
医学的なネブライザー
オゾン発生器
ふくらませて使う包装機械
はんだ除去装置

農業通気
燃料電池
空気サンプリング
液体の動揺
エアマットレス
連続した圧縮(循環療法)
血液カフ・モニター
膜酸素発生器



Model No. DL40, DL60

Linear Air Pump

DL40

Product Dimension (inch, mm)

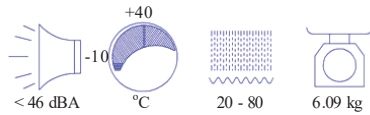
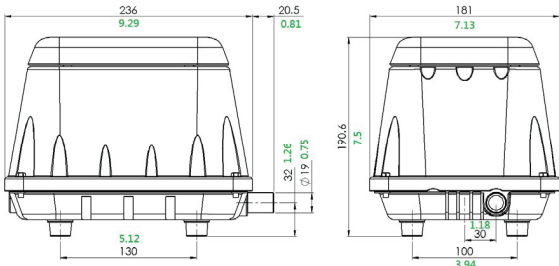

Product Specification

Model No.	Voltage (VAC)	Frequency (Hz)	Rated Pressure (kg/cm ²)	Airflow (LPM)	AMP (A)	WATT (W)
DL40	110 ~ 120	60	0.13	47	0.9	45
DL40	220 ~ 240	50	0.13	50	0.46	43

Operating range : 0.05 to 0.2 kg/cm²

Performance Curve

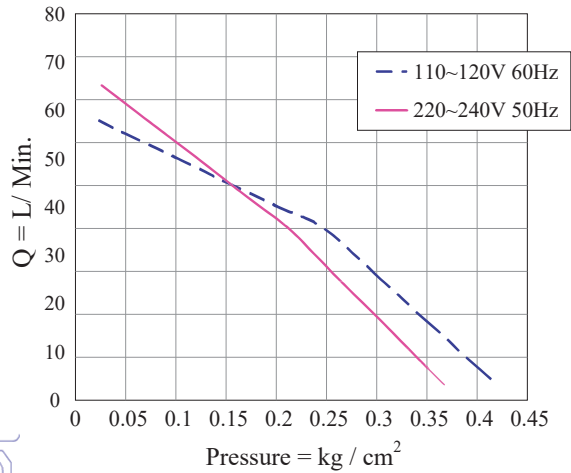

DL60

Product Dimension (inch, mm)

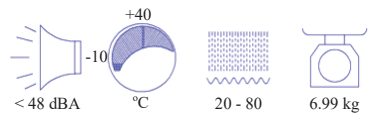
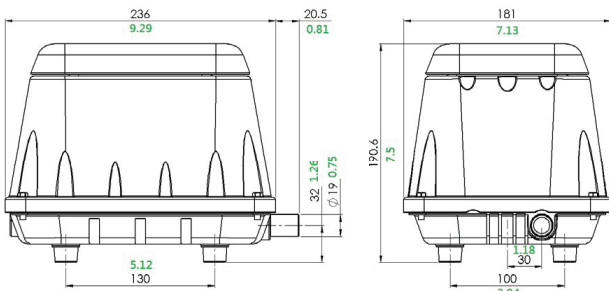

Product Specification

Model No.	Voltage (VAC)	Frequency (Hz)	Rated Pressure (kg/cm ²)	Airflow (LPM)	AMP (A)	WATT (W)
DL60	110 ~ 120	60	0.15	68	1.3	63
DL60	220 ~ 240	50	0.15	66	0.6	61

Operating range : 0.05 to 0.2 kg/cm²

Performance Curve

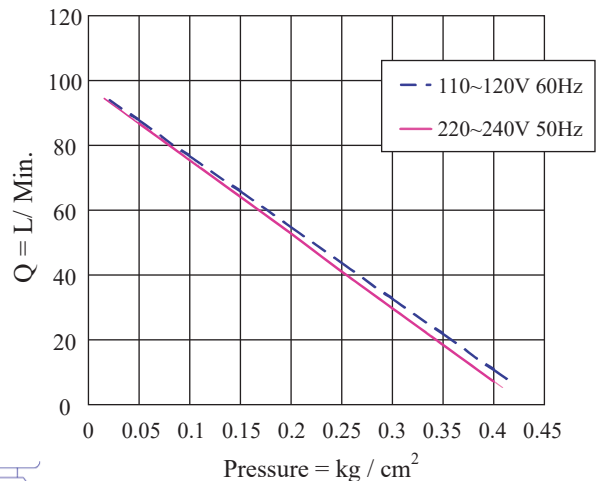



Model No. DLX80, DLX100

Linear Air Pump

DLX80

Product Dimension (inch, mm)

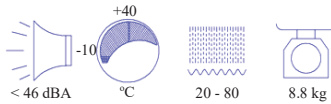
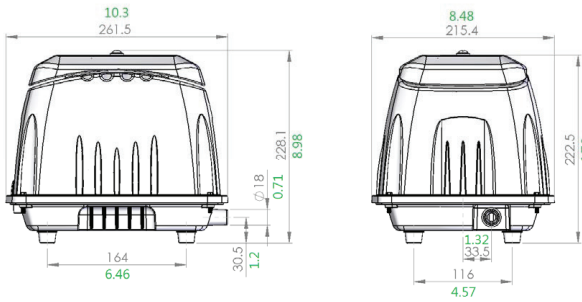

Product Specification

Model No.	Voltage (VAC)	Frequency (Hz)	Rated Pressure (kg/cm ²)	Airflow (LPM)	AMP (A)	WATT (W)
DLX80	110 ~ 120	60	0.18	83	1.1	71
DLX80	220 ~ 240	50	0.18	83	0.52	68

Operating range : 0.05 to 0.2 kg/cm²

Performance Curve

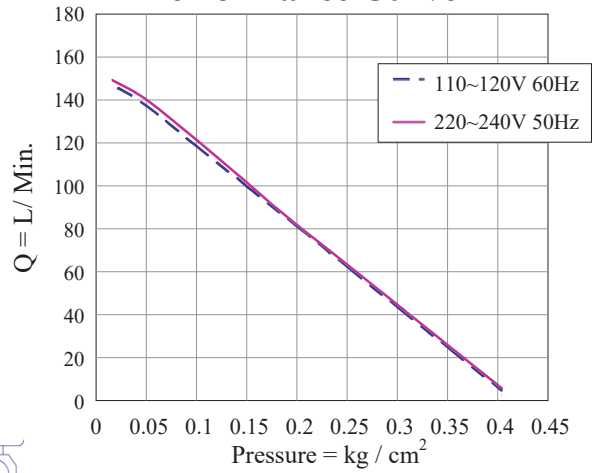

DLX100

Product Dimension (inch, mm)

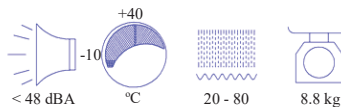
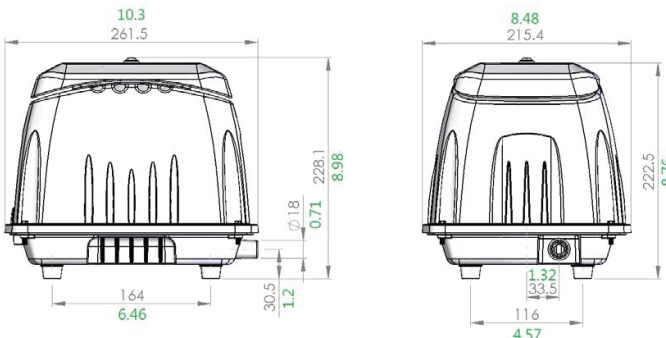

Product Specification

Model No.	Voltage (VAC)	Frequency (Hz)	Rated Pressure (kg/cm ²)	Airflow (LPM)	AMP (A)	WATT (W)
DLX100	110 ~ 120	60	0.18	100	1.4	94
DLX100	220 ~ 240	50	0.18	100	0.7	87

Operating range : 0.05 to 0.2 kg/cm²

Performance Curve

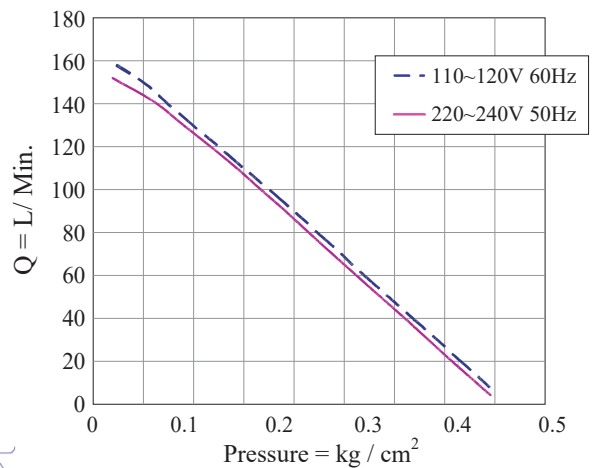



Model No. DLX120, DLX150

Linear Air Pump

DLX120

Product Dimension (inch, mm)

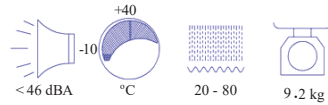
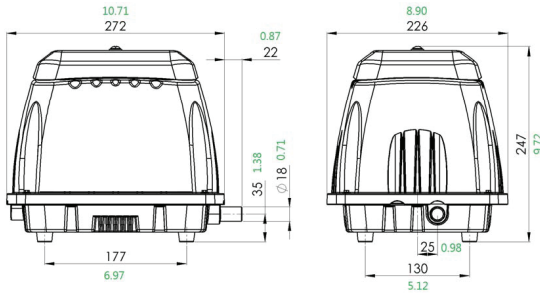

Product Specification

Model No.	Voltage (VAC)	Frequency (Hz)	Rated Pressure (kg/cm ²)	Airflow (LPM)	AMP (A)	WATT (W)
DLX120	110 ~ 120	60	0.2	120	1.5	126
DLX120	220 ~ 240	50	0.2	120	1.0	119

Operating range : 0.05 to 0.2 kg/cm²

Performance Curve

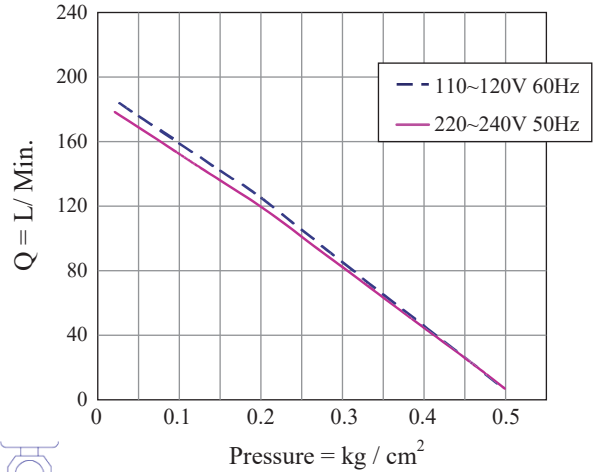

DLX150

Product Dimension (inch, mm)

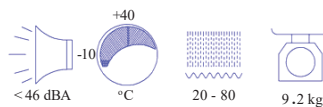
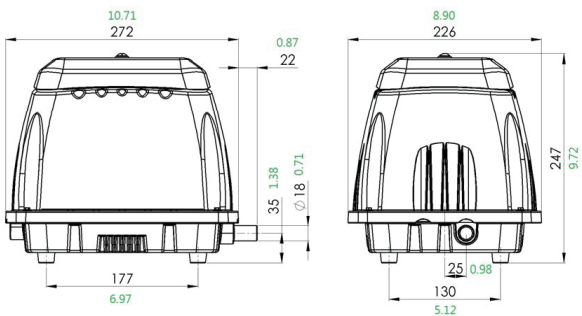

Product Specification

Model No.	Voltage (VAC)	Frequency (Hz)	Rated Pressure (kg/cm ²)	Airflow (LPM)	AMP (A)	WATT (W)
DLX150	110 ~ 120	60	0.2	150	2.1	134
DLX150	220 ~ 240	50	0.2	150	1.2	130

Operating range : 0.05 to 0.2 kg/cm²

Performance Curve

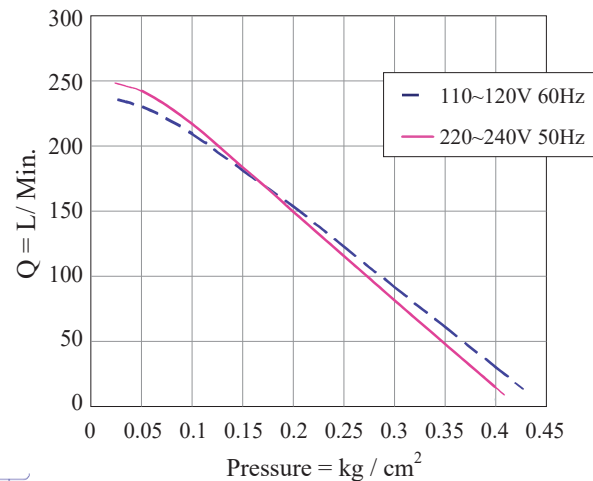



Model No. DLX200, DLX250

Linear Air Pump

DLX200

Product Dimension (inch, mm)

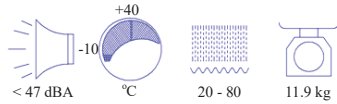
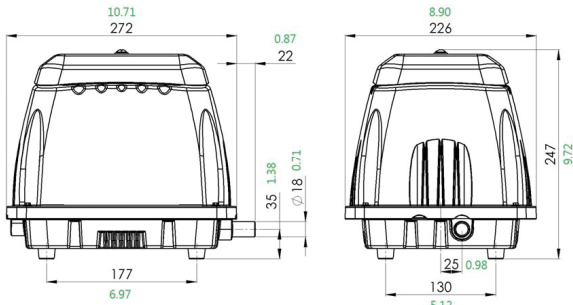

Product Specification

Model No.	Voltage (VAC)	Frequency (Hz)	Rated Pressure (kg/cm ²)	Airflow (LPM)	AMP (A)	WATT (W)
DLX200	110 ~ 120	60	0.2	200	3.2	190
DLX200	220 ~ 240	50	0.2	200	1.75	186

Operating range : 0.05 to 0.2 kg/cm²

Performance Curve

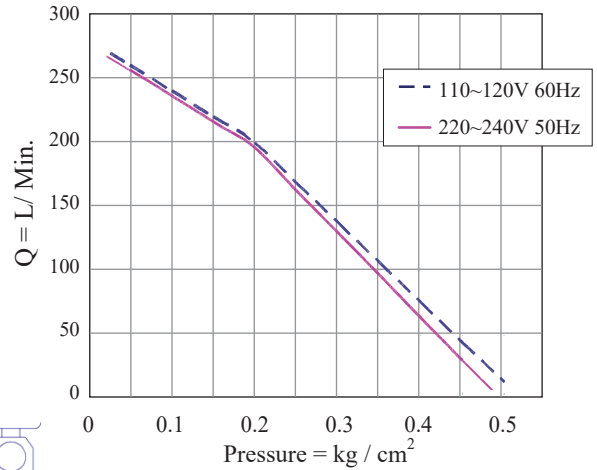

DLX250

Product Dimension (inch, mm)

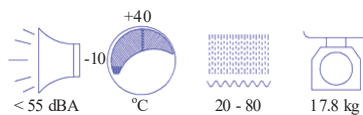
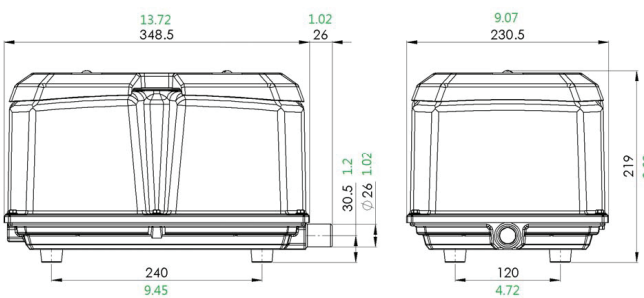

Product Specification

Model No.	Voltage (VAC)	Frequency (Hz)	Rated Pressure (kg/cm ²)	Airflow (LPM)	AMP (A)	WATT (W)
DLX250	110 ~ 120	60	0.2	250	3.2	220
DLX250	220 ~ 240	50	0.2	250	1.8	202

Operating range : 0.05 to 0.2 kg/cm²

Performance Curve

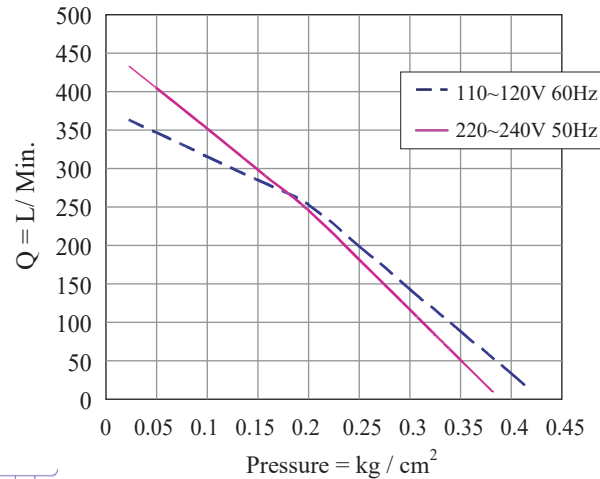



Model No. DLX300, DLX400

Linear Air Pump

DLX300

Product Dimension (inch, mm)

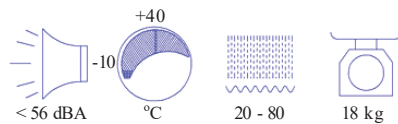
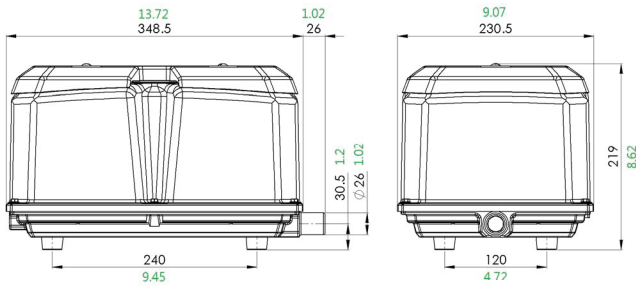

Product Specification

Model No.	Voltage (VAC)	Frequency (Hz)	Rated Pressure (kg/cm ²)	Airflow (LPM)	AMP (A)	WATT (W)
DLX300	110 ~ 120	60	0.2	300	4.3	281
DLX300	220 ~ 240	50	0.2	300	2.6	298

Operating range : 0.05 to 0.2 kg/cm²

Performance Curve

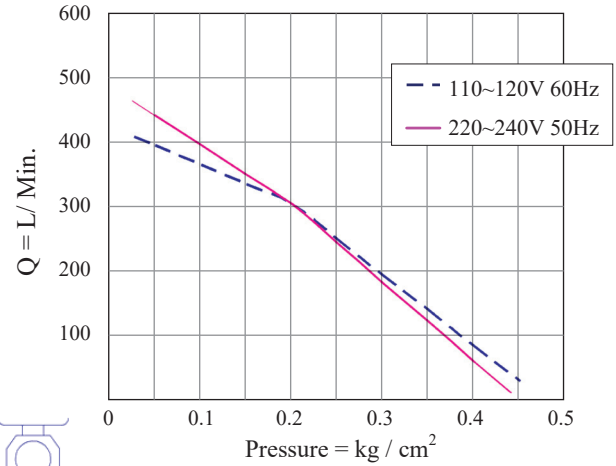

DLX400

Product Dimension (inch, mm)

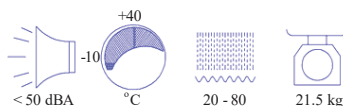
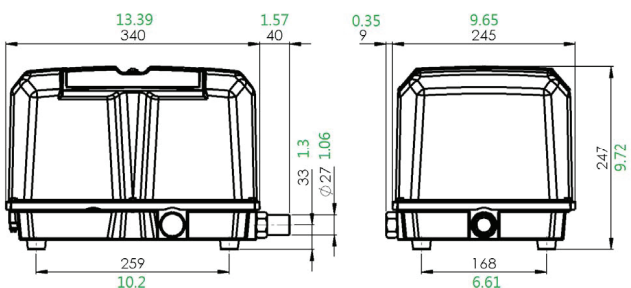

Product Specification

Model No.	Voltage (VAC)	Frequency (Hz)	Rated Pressure (kg/cm ²)	Airflow (LPM)	AMP (A)	WATT (W)
DLX400	110 ~ 120	60	0.2	400	4.3	350
DLX400	220 ~ 240	50	0.2	400	2.6	350

Operating range : 0.05 to 0.2 kg/cm²

Performance Curve

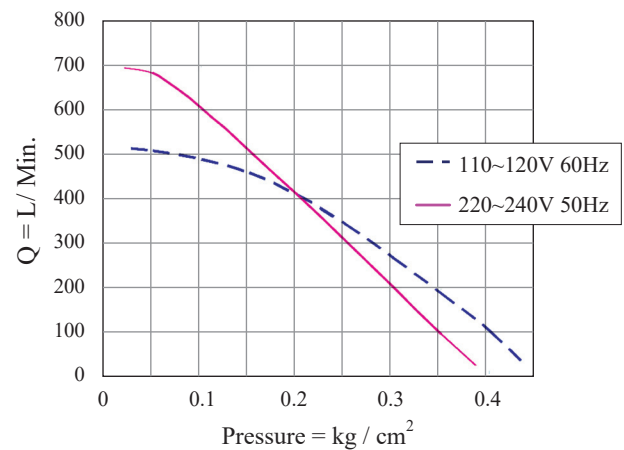



Model No. DLX500

Linear Air Pump

DLX500

Product Dimension (inch, mm)

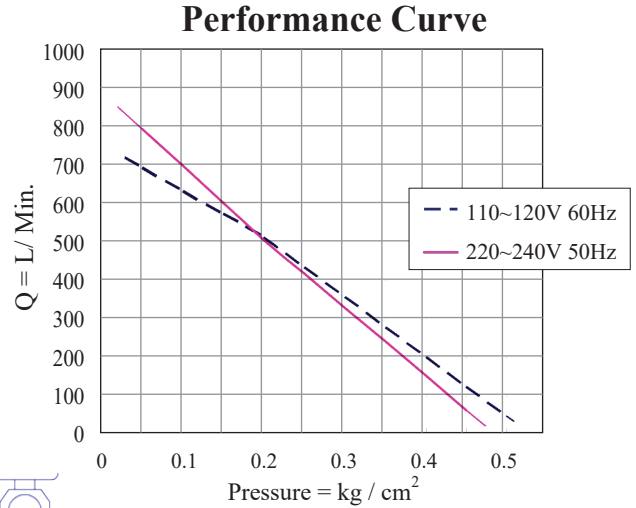
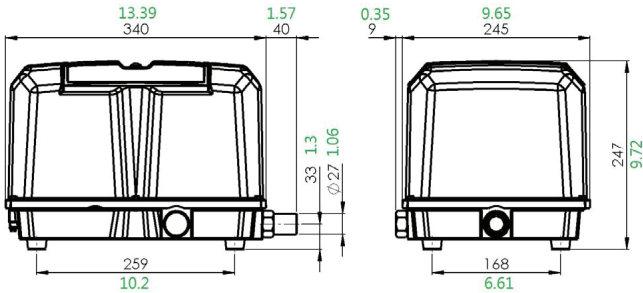

Product Specification

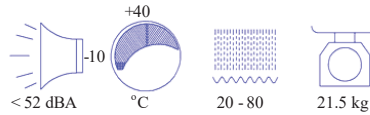

Model No.	Voltage (VAC)	Frequency (Hz)	Rated Pressure (kg/cm ²)	Airflow (LPM)	AMP (A)	WATT (W)
DLX500	110 ~ 120	60	0.2	500	6.8	455
DLX500	220 ~ 240	50	0.2	500	3.7	460

Operating range : 0.05 to 0.2 kg/cm²

Accessories

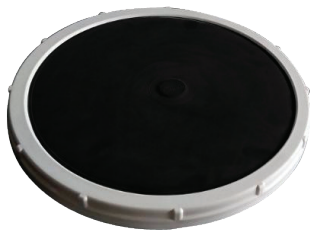

Fine Bubble Diffuser



Tube Connector



Pressure Gauges



Fine Bubble Tube Diffuser



Distributor

SATO
AIR PUMP
佐藤エアポンプ



MBSAT-DCA01