

ROOT BLOWER & VACUUM PUMP
ARC- X SERIES
DATA BOOK

UNOMACH
(NEW)

ARC

THREE LOBE ROTARY BLOWER

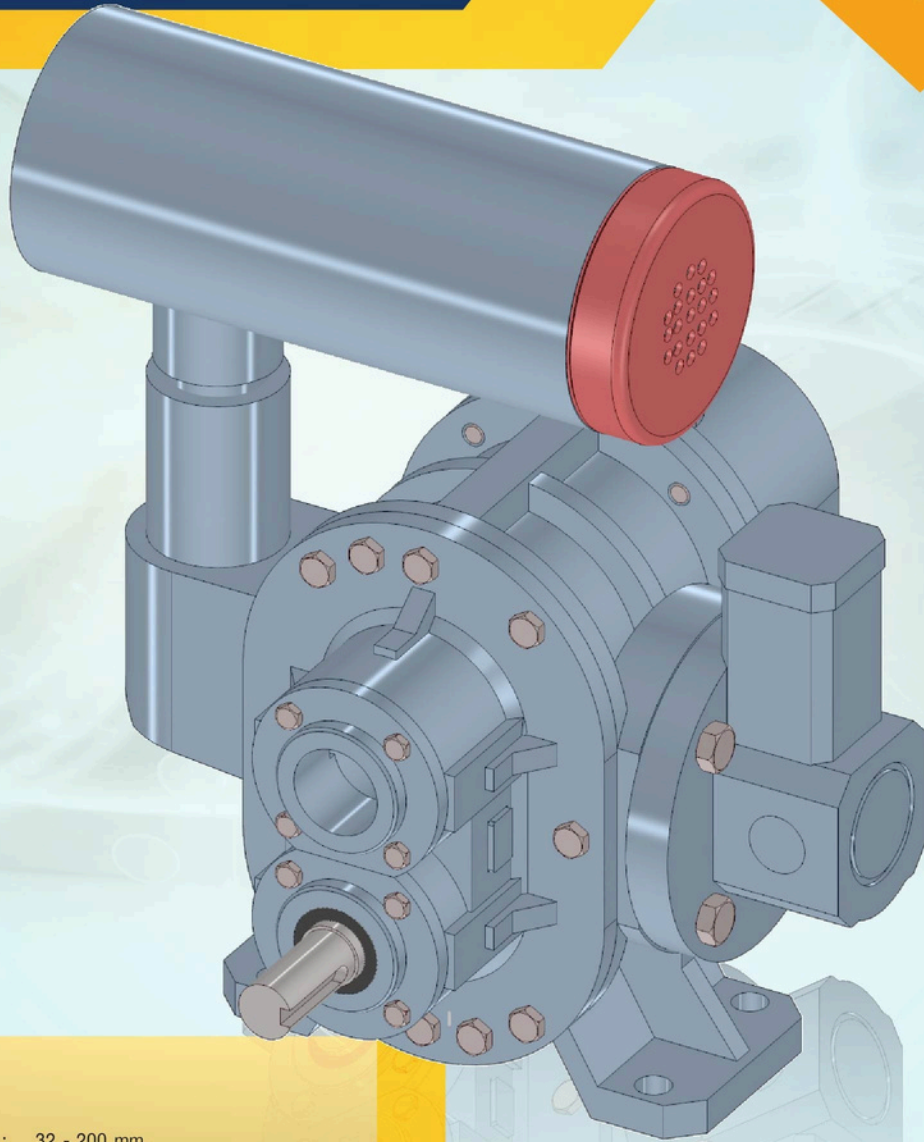

Blower

Piping size : 32 - 200 mm.
Suction pressure : Atmospheric pressure
Discharge pressure : 1000 - 6000 mmAq.
Capacity : 0.68 - 59.20 m³/min.

Vacuum Pumps

Piping size : 32 - 200 mm.
Suction pressure : (-1000) - (-6000) mmAq.
Discharge pressure : Atmospheric pressure
Capacity : 0.68 - 59.20 m³/min.

 The quality products have been well known in industry market for long time. They have been accepted in waste water treatment plant, aquarium, spa, incinerator, press machinery and pneumatic conveyor system, etc.



Three Lobe Positive Displacement Blower

UNOMACH has been recognized as one of the leading brands in the field of air blower and vacuum pump. Our ARC- X Series have been tested with highly satisfactory results in many applications ranging from wastewater treatment plant, oxygen supply to aquarium, spa pool, sand blasting, incinerator, press machinery, power and granular material transport, and many other pneumatic conveying applications, as well as smoke extraction from clean room, vacuum packing, vacuum drying, vacuum car and vacuum casting.

Our ARC- X Series technology of three-lobe rotary blower has surpassed that of the competitors and resulted in less noise operation and longer life time.

In addition, we supply acoustic enclosure for the air blowers in order to meet the requirement of extremely sensitive noise area.

Moreover, we have air diffusers which give very fine bubbles easily dissolved into water, resulting in high oxygen transfer rate.

We have factories in many countries and we emphasize on the quality control. So our customers can be assured of the quality and have peace of mind when they use our products.

Advantages

*Three lobe rotor blower and vacuum pump :

An ideal air handler usable to satisfy a number of work conditions, the new series low noise units can be used to satisfy a wide range of user requirements. The specifications are as follows.

This catalogue details air capacities, noise characteristics and external dimensions of units-so pick the model that meets your needs.

Control of Blower Speed

When blower's discharge pressure remains constant, its air volume and horse power are proportional to blower speed. When you need to adjust air volume, it is recommended not to discharge extra air into the open air, but to reduce blower speed to reduce horse power. This will greatly contribute to a reduction in power consumption. Usually, a variable speed motor is used and its rpms are controlled in response to pressure or air volume signals. Maximum and minimum blower speed differ according to service conditions, so please consult us for the necessary information.

Blowers

Piping size	: 32 - 200 mm.
Suction pressure	: Atmospheric pressure
Discharge pressure	: 1000 - 6000 mmAq.
Capacity	: 0.68 - 59.20 m ³ /min.

Vacuum Pumps

Piping size	: 32 - 200 mm.
Suction pressure	: (-1000) - (-6000) mmAq.
Discharge pressure	: Atmospheric pressure
Capacity	: 0.68 - 59.20m ³ /min.

* Low noise - less vibration

Due to the three lobe rotor, pulsations of air discharge from the blower have been greatly reduced. noise and vibration have also significantly eliminated.

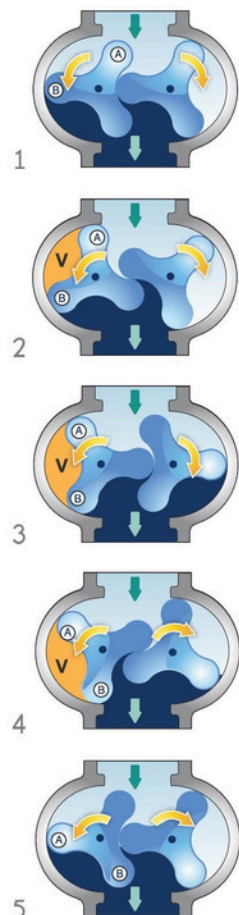

Principle

A pair of rotors turn in opposite directions inside the casing, maintaining a precision clearance between the inside wall of the casing and the two rotors. Air is taken into the blower as the lobe end of each rotor passes the suction port and transferred from the suction side to the discharge side.

It is then discharged, forced towards the high pressure side. Air at the suction side is caught in volume "A" surrounded by lobe ends (A), (B) and the casing in process as shown in illustrations (1) and (2) at right, and after steps (3) and (4), is discharged (step 5). With three lobes, this process is repeated six times per one rotation and constant volume of air proportional to the number of revolutions are discharged.

Advantages of the three lobe rotor

Compression takes place when the rotor's lobe end faces the discharge port and high pressure air at the discharge side flow back into the casing.

The main cause of blower noise lies in this pulsation of pressure that accompanies the back-flow compression. In case of the three lobe rotor, the cycle of pulsation is 2/3 that of the two lobe rotor. The pressure peak value also reduces. In addition, since the three lobe rotor is of specially designed construction so as to minimize the range of pulsations, pulsations at the discharge port have been conspicuously reduced, compared with the two lobe rotor. Consequently, the back-flow compression of blower is done smoothly and noise level greatly lowered. Since discharge air pulsations have been smoothed, changes in axial torque and bearing load, and vibration and noise of timing gear and bearing have been remarkably reduced.

The ARC- X Blowers are available with many types of standard shaft sealing. The type of blower shaft sealing is selected according to the gas handled. When handling a special kind of gas, a mechanical seal is provided-either single or double mechanical seal can be used. Available types of shaft sealing and their general uses are as follows :

1. Standard types:

The standard type for blower mainly suitable for blower that handles air.

- Seal position **A** Oil seal
- Seal position **B** Labyrinth seal
- Seal position **C** Labyrinth seal

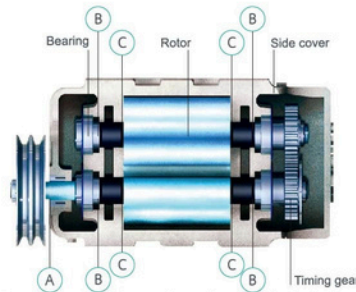

Detail of the standard shaft seal



Seal position **A**
(Oil seal)



Seal position **B**
(Labyrinth seal)



Seal position **C**
(Labyrinth seal)

2. One-mechanical seal 'K' type:

Provided with one mechanical seal on the shaft. Suitable for sealing the shaft when gases that should not be leaked into air are handled-N₂, H₂, Ar, CO, CO₂ and other non-solvent gases; and also coke oven gas, city gas, digested gas, etc. This type is available with either of two systems of "Ka" and "Kb" at seal position "A" according to working pressure and the water content of those gas being handled.

Type "Ka"	Type "Kb"
Seal position A Single mechanical seal	Double mechanical seal
Seal position B Oil seal or Labyrinth seal	Oil seal or Labyrinth seal
Seal position C Labyrinth seal	Labyrinth seal

3. Four-mechanical seal 'B' type:

Mechanical seals are provided at four points on the back of the bearing. Used for sealing the shaft when handling solvent gases. This type is available with either single mechanical seals or double mechanical seals according to the constituents of the gas being handled.

Type "Ba"	Type "Bb"
Seal position A Oil seal	Oil seal
Seal position B Single mechanical seal	Double mechanical seal
Seal position C Labyrinth seal	Labyrinth seal

4. Four-mechanical seal 'I' type:

Mechanical seals are provided at four positions of the rotor shaft. Handled gas is completely separated from the bearing.

Type "Ia"	Type "Ib"
Seal position A Oil seal	Oil seal
Seal position B Labyrinth seal	Labyrinth seal
Seal position C Single mechanical seal	Double mechanical seal

Application

1. As an air blower:

For pneumatic conveyors and the chemical industry for humidifying and aeration to water treatment and blending and aeration of powder or granular foods, cement, or vinyl.

2. As a gas blower:

For pressurized transportation or circulation of gases in chemical processes. Hydrogen, Nitrogen, Acetylene, Oxygen, Kerosene gas, Methane, Sulfurous acid gas, Stack flue gas, City gas, Carbonic acid gas, Hydrogen sulfide gas, and Hydrochloric acid gas.

3. As a vacuum pump:

Filtration equipment in the chemical industry, Pneumatic conveyors, Ship unloading.

Fishery pond enzyme supply

Used for underwater enzyme supply in comparatively shallow ponds.

Printing press paper feed

Operations are simplified by using discharge air to separate, align, and feed the paper.

Gas burner

High-pressure discharge air can be used to disperse the fuel.

Airbrush

High-pressure discharge air containing no oil is extremely well-received for airbrush applications.

Stamping die

Used to remove the stamped work-piece from the die.

Therapeutic bath

Widely used in hospitals and hotels for healthy bath aeration.

Sandblasting

Used as the air source for sandblasting.

Spraying

Used to supply high-pressure discharge air containing no oil to the sprayer.

Purification tank

Used to agitate sediment and for purification at water treatment plants.

Furnace

The blower can help boost burn performance and promote exhaust gas removal.

Dessication line

Used on small-scale dessication lines.

Grain transfer

Used for pneumatic transport of wheat or other grain separated by a rotary valve.

Backwash

Used as a backwash for filters.

Ballast pump

Used for liquid chemical ship lowering and other types of ballast pumping.

Fertilizer production using manure fermentation

Used to hasten fermentation by feeding air.

Plating tank

To improve the quality of plating, air is fed into the tank to recirculate the electrolyte. The Roots blower is used as the air source.

Pipe cleaning

Used to remove dust and rust when replacing piping or conducting periodic inspections.

Bottle washer

Used to remove water droplets remaining inside bottles after washing.

Particles transport

Used for air transfer of of pellet materials such as vinyl chloride or polyethylene (can also be used for suction type applications).

Circulation

Used for the recirculation of nitrogen, carbon dioxide, city gas, LP gas, etc.

Noise emissions from the rotary blower fluctuate depending upon blower size, discharge pressure and number of revolutions. The blower noise level is measured according to JIS B 8346 Noise Level Measuring method for Blower and Compressors. Noise is measured at 4 6 spots which are 1m apart from the blower depending on its size. Based on the measurement, a typical noise value is calculated according to the following formula.

$$\bar{L} = 10 \log_{10} (10^{\frac{L_1}{10}} + 10^{\frac{L_2}{10}} + \dots + 10^{\frac{L_n}{10}}) - 10 \log_{10} n$$

Where \bar{L} : typical noise level [dB(A)]

$L_1, L_2 \dots L_n$: measured value [dB(A)]

n : number of measured values

Typical noise values shown below are estimated values that will be obtained when measured values that will be obtained according to the JIS mode above.

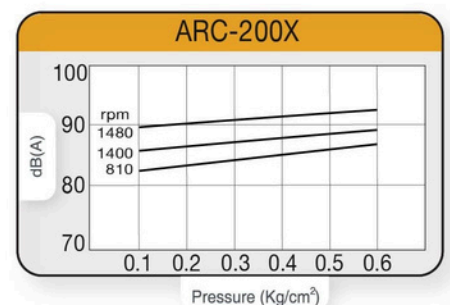
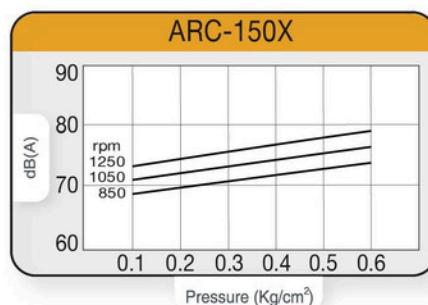
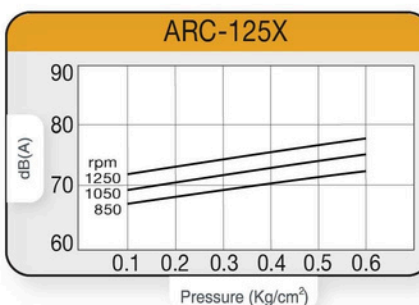
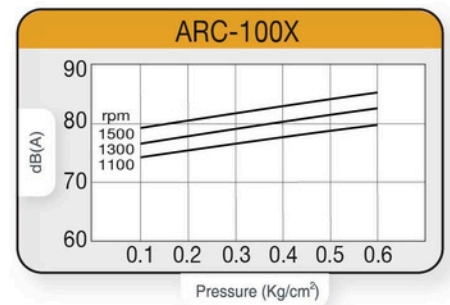
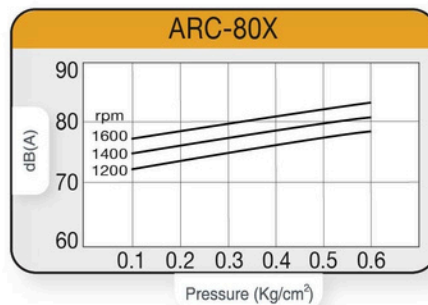
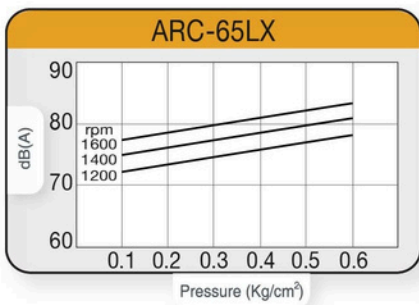
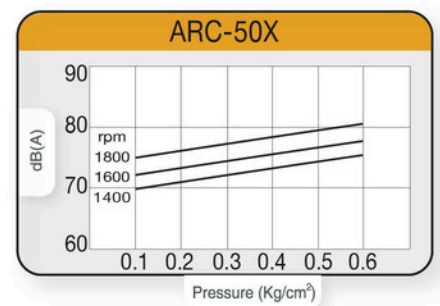
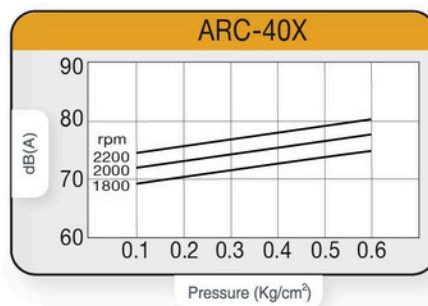
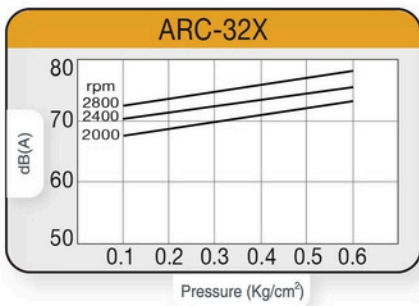

Performance Table

MODEL ARC 32X		Discharge Pressure (kgf/cm ²)																							
		RPM	0.10		0.15		0.20		0.25		0.30		0.35		0.40		0.45		0.50		0.55		0.60		
			9.8kPa		14.7kPa		19.6kPa		24.5kPa		29.4kPa		34.4kPa		39.2kPa		44.1kPa		49kPa		53.9kPa		58.8kPa		
			Qs	La	Qs	La	Qs	La	Qs	La	Qs	La	Qs	La	Qs	La	Qs	La	Qs	La	Qs	La	Qs	La	Qs
SIZE 32	2000	0.68	0.21	0.67	0.26	0.66	0.34	0.65	0.38	0.64	0.42	0.62	0.48	0.61	0.53	0.60	0.57	0.58	0.61	0.57	0.66	0.55	0.71		
	2150	0.73	0.24	0.72	0.31	0.71	0.39	0.70	0.44	0.69	0.48	0.66	0.55	0.65	0.60	0.64	0.65	0.63	0.69	0.62	0.75	0.61	0.80		
	2300	0.78	0.27	0.77	0.35	0.76	0.44	0.75	0.49	0.74	0.55	0.70	0.62	0.69	0.68	0.68	0.74	0.67	0.77	0.66	0.84	0.65	0.91		
	2450	0.83	0.30	0.82	0.39	0.81	0.49	0.80	0.54	0.79	0.61	0.75	0.69	0.74	0.76	0.73	0.83	0.72	0.86	0.70	0.93	0.69	1.01		
	2600	0.88	0.33	0.87	0.44	0.86	0.54	0.85	0.60	0.84	0.68	0.80	0.76	0.79	0.84	0.78	0.92	0.77	0.96	0.75	1.02	0.73	1.12		
	2750	0.93	0.36	0.92	0.48	0.91	0.59	0.90	0.65	0.88	0.73	0.85	0.83	0.83	0.91	0.82	1.00	0.81	1.05	0.79	1.13	0.77	1.23		
	2900	0.98	0.40	0.97	0.53	0.96	0.64	0.94	0.72	0.92	0.80	0.90	0.90	0.88	0.99	0.87	1.08	0.85	1.15	0.82	1.24	0.80	1.33		

MODEL ARC 40X		Discharge Pressure (kgf/cm ²)																							
		RPM	0.10		0.15		0.20		0.25		0.30		0.35		0.40		0.45		0.50		0.55		0.60		
			9.8kPa		14.7kPa		19.6kPa		24.5kPa		29.4kPa		34.4kPa		39.2kPa		44.1kPa		49kPa		53.9kPa		58.8kPa		
			Qs	La	Qs	La	Qs	La	Qs	La	Qs	La	Qs	La	Qs	La	Qs	La	Qs	La	Qs	La	Qs	La	Qs
SIZE 40	1450	1.34	0.44	1.33	0.51	1.30	0.58	1.27	0.64	1.24	0.73	1.21	0.79	1.16	0.89	1.11	0.99	1.05	1.01	1.10	1.13	1.05	1.25		
	1600	1.52	0.55	1.49	0.59	1.46	0.65	1.43	0.73	1.40	0.82	1.36	0.91	1.32	1.00	1.27	1.11	1.22	1.22	1.17	1.35	1.12	1.48		
	1750	1.67	0.61	1.63	0.68	1.59	0.75	1.55	0.84	1.51	0.93	1.47	1.02	1.43	1.13	1.38	1.25	1.32	1.38	1.27	1.51	1.22	1.69		
	1850	1.75	0.68	1.70	0.77	1.66	0.87	1.63	0.96	1.59	1.05	1.55	1.16	1.50	1.28	1.46	1.40	1.43	1.53	1.39	1.65	1.34	1.81		
	2000	1.90	0.74	1.86	0.83	1.83	0.92	1.80	1.11	1.77	1.23	1.73	1.35	1.68	1.41	1.63	1.53	1.59	1.76	1.54	1.88	1.49	2.02		

MODEL ARC 50X		Discharge Pressure (kgf/cm ²)																							
		RPM	0.10		0.15		0.20		0.25		0.30		0.35		0.40		0.45		0.50		0.55		0.60		
			9.8kPa		14.7kPa		19.6kPa		24.5kPa		29.4kPa		34.4kPa		39.2kPa		44.1kPa		49kPa		53.9kPa		58.8kPa		
			Qs	La	Qs	La	Qs	La	Qs	La	Qs	La	Qs	La	Qs	La	Qs	La	Qs	La	Qs	La	Qs	La	Qs
SIZE 50	1450	1.95	0.64	1.90	0.83	1.86	0.98	1.82	1.10	1.78	1.25	1.74	1.37	1.69	1.55	1.63	1.68	1.60	1.77	1.56	1.92	1.51	1.99		
	1550	2.07	0.67	2.02	0.94	1.98	1.08	1.94	1.23	1.89	1.36	1.85	1.54	1.81	1.71	1.76	1.81	1.71	1.89	1.66	1.97	1.61	2.05		
	1650	2.16	0.77	2.12	1.01	2.09	1.21	2.05	1.35	2.01	1.49	1.97	1.69	1.93	1.87	1.87	2.02	1.82	2.18	1.77	2.35	1.72	2.52		
	1750	2.31	0.83	2.26	1.11	2.21	1.33	2.16	1.50	2.11	1.64	2.06	1.85	2.02	2.07	1.98	2.24	1.94	2.40	1.90	2.60	1.86	2.78		
	1850	2.47	0.91	2.42	1.21	2.37	1.44	2.32	1.65	2.25	1.82	2.20	2.05	2.15	2.26	2.10	2.44	2.04	2.63	1.98	2.83	1.92	3.03		
	1950	2.58	1.00	2.51	1.33	2.45	1.59	2.39	1.80	2.33	2.00	2.28	2.25	2.24	2.48	2.20	2.69	2.16	2.88	2.11	3.11	2.07	3.32		

MODEL ARC 65X		Discharge Pressure (kgf/cm ²)																						
		RPM	0.10		0.15		0.20		0.25		0.30		0.35		0.40		0.45		0.50		0.55		0.60	
			9.8kPa		14.7kPa		19.6kPa		24.5kPa		29.4kPa		34.4kPa		39.2kPa		44.1kPa		49kPa		53.9kPa		58.8kPa	
			Qs	La	Qs	La	Qs	La	Qs	La	Qs	La	Qs	La	Qs	La	Qs	La	Qs	La	Qs	La	Qs	La
SIZE 65	1350	3.35	1.38	3.28	1.53	3.20	1.71	3.13	1.92	3.06	2.13	2.99	2.40	2.93	2.64	2.86	2.87	2.80	3.07	2.72	3.30	2.64	3.53	
	1450	3.56	1.43	3.48	1.65	3.41	1.89	3.33	2.13	3.26	2.36	3.19	2.66	3.12	2.93	3.06	3.18	2.98	3.40	2.91	3.66	2.83	3.92	
	1550	3.75	1.59	3.67	1.88	3.59	2.12	3.51	2.35	3.43	2.60	3.36	2.93	3.29	3.23	3.23	3.49	3.16	3.75	3.09	4.03	3.01	4.31	
	1650	3.98	1.73	3.91	1.99	3.84	2.29	3.77	2.58	3.69	2.86	3.61	3.21	3.54	3.54	3.46	3.85	3.38	4.12	3.30	4.43	3.22	4.75	
	1750	4.19	1.89	4.16	2.25	4.10	2.58	4.03	2.82	3.95	3.13	3.84	3.53	3.78	3.89	3.71	4.22	3.62	4.52	3.52	4.88	3.41	5.21	
	1850	4.42	2.12	4.35	2.41	4.26	2.79	4.18	3.10	4.09	3.43	4.00	3.87	3.92	4.27	3.84	4.63	3.76	4.94	3.68	5.34	3.59	5.71	

MODEL ARC 80X		Discharge Pressure (kgf/cm ²)																						
		RPM	0.10		0.15		0.20		0.25		0.30		0.35		0.40		0.45		0.50		0.55		0.60	
			9.8kPa		14.7kPa		19.6kPa		24.5kPa		29.4kPa		34.4kPa		39.2kPa		44.1kPa		49kPa		53.9kPa		58.8kPa	
			Qs	La	Qs	La	Qs	La	Qs	La	Qs	La	Qs	La	Qs	La	Qs	La	Qs	La	Qs	La	Qs	La
SIZE 80	1250	4.77	1.82	4.69	2.03	4.61	2.36	4.53	2.68	4.45	2.95	4.37	3.27	4.29	5.63	4.18	3.92	4.08	4.18	3.99	4.51	3.88	4.86	
	1350	5.03	1.99	4.95	2.23	4.87	2.68	4.79	3.02	4.70	3.37	4.62	3.80	4.54	4.21	4.46	5.57	4.37	4.88	4.28	5.28	4.19	5.57	
	1450	5.58	2.14	5.49	2.50	5.40	2.99	5.31	3.38	5.22	3.76	5.11	4.23	5.01	4.67	4.90	5.06	4.79	5.42	4.68	5.79	4.57	6.25	
	1550	5.85	2.40	5.77	2.74	5.68	3.30	5.59	3.75	5.50	4.15	5.41	4.68	5.32	5.16	5.23	5.62	5.14	6.01	5.05	6.48	4.96	6.94	
	1650	6.54	2.68	6.43	3.04	6.32	3.64	6.21	4.12	6.10	4.57	5.99	5.15	5.88	5.70	5.76	6.17	5.63	6.60	5.51	7.14	5.39	7.65	
	1750	6.98	3.09	6.86	3.35	6.77	4.01	6.68	4.52	6.57	4.98	6.46	5.63	6.35	6.21	6.24	6.72	6.12	7.22	6.01	7.78	5.78	8.34	

MODEL ARC 100X		Discharge Pressure (kgf/cm ²)																						
		RPM	0.10		0.15		0.20		0.25		0.30		0.35		0.40		0.45		0.50		0.55		0.60	
			9.8kPa		14.7kPa		19.6kPa		24.5kPa		29.4kPa		34.4kPa		39.2kPa		44.1kPa		49kPa		53.9kPa		58.8kPa	
			Qs	La	Qs	La	Qs	La	Qs	La	Qs	La	Qs	La	Qs	La	Qs	La	Qs	La	Qs	La	Qs	La
SIZE 100	1250	8.72	3.43	8.56	4.13	8.41	4.84	8.25	5.52	8.11	6.28	7.92	6.88	7.74	7.52	7.57	8.18	7.41	8.83	7.28	9.39	7.06	10.05	
	1350	9.39	3.73	9.25	4.49	9.12	5.23	8.97	5.89	8.83	6.67	8.64	7.39	8.43	8.12	8.21	8.85	7.98	9.59	7.81	10.31	7.61	11.06	
	1450	10.11	4.05	9.94	4.87	9.81	5.68	9.64	6.52	9.51	7.42	9.27	8.28	9.06	9.14	8.84	9.93	8.63	10.73	8.42	11.52	8.21	12.19	
	1550	10.75	4.41	10.64	5.26	10.51	6.20	10.36	7.18	10.23	8.23	9.98	9.09	9.77	9.92	9.52	10.78	9.28	11.66	9.04	12.49	8.81	13.38	
	1650	11.42	4.85	11.26	5.91	11.31	7.05	10.95	8.09	10.82	9.03	10.57	9.98	10.33	10.93	10.08	11.89	9.72	12.95	9.57	13.81	9.31	14.72	
	1750	12.14	5.19	11.96	6.36	11.78	7.51	11.62	8.58	11.46	9.74	11.19	10.77	10.91	11.89	10.63	12.92	10.41	14.05	10.14	15.04	9.87	16.15	

Performance Table

MODEL ARC 125X	RPM	Discharge Pressure (kgf/cm ²)																							
		0.10		0.15		0.20		0.25		0.30		0.35		0.40		0.45		0.50		0.55		0.60			
		9.8kPa		14.7kPa		19.6kPa		24.5kPa		29.4kPa		34.4kPa		39.2kPa		44.1kPa		49kPa		53.9kPa		58.8kPa			
		Qs	La	Qs	La	Qs	La	Qs	La	Qs	La	Qs	La	Qs	La	Qs	La	Qs	La	Qs	La	Qs	La	Qs	La
SIZE 125	980	13.08	4.37	12.98	5.82	12.81	6.99	12.59	7.89	12.31	8.74	11.98	9.85	11.79	10.87	11.56	11.79	11.28	12.62	10.97	13.61	10.61	14.56		
	1050	14.02	4.78	13.90	6.38	13.73	7.65	13.50	8.63	13.19	9.56	12.83	10.79	12.63	11.90	12.38	12.91	12.09	13.81	11.75	14.90	11.36	15.94		
	1200	16.02	5.59	15.89	7.45	15.69	8.94	15.42	10.09	15.08	11.17	14.67	12.60	14.44	13.90	14.15	15.08	13.82	16.14	13.43	17.41	12.99	18.62		
	1310	17.49	6.24	17.35	8.32	17.13	9.98	16.83	11.26	16.43	12.47	16.01	14.07	15.76	15.52	16.84	15.08	18.02	14.66	19.44	14.18	20.79			
	1390	18.56	6.77	18.41	9.03	18.18	10.84	17.86	12.23	17.47	13.54	16.99	15.28	16.72	16.86	16.39	18.29	16.01	19.56	15.56	21.11	15.04	22.57		
	1450	19.36	7.23	19.20	9.64	19.20	11.57	18.63	13.06	18.22	14.47	17.72	16.31	17.44	18.00	17.10	19.53	16.70	20.89	16.23	22.54	15.69	24.11		
	1530	20.43	7.82	20.26	10.42	20.01	12.51	19.66	14.12	19.22	15.64	18.70	17.63	18.41	19.46	18.05	21.11	17.62	22.59	17.12	24.37	16.56	26.06		

MODEL ARC 150X	RPM	Discharge Pressure (kgf/cm ²)																							
		0.10		0.15		0.20		0.25		0.30		0.35		0.40		0.45		0.50		0.55		0.60			
		9.8kPa		14.7kPa		19.6kPa		24.5kPa		29.4kPa		34.4kPa		39.2kPa		44.1kPa		49kPa		53.9kPa		58.8kPa			
		Qs	La	Qs	La	Qs	La	Qs	La	Qs	La	Qs	La	Qs	La	Qs	La	Qs	La	Qs	La	Qs	La	Qs	La
SIZE 150	810	13.70	4.28	13.59	5.72	13.42	6.80	13.18	7.72	12.89	8.51	12.54	9.80	12.34	10.90	12.10	12.01	11.81	13.21	11.48	14.56	11.10	15.92		
	860	14.54	4.52	14.43	6.10	14.24	7.40	14.00	8.44	13.69	9.45	13.31	10.77	13.11	12.02	12.85	13.19	12.54	14.27	12.19	15.58	11.79	16.86		
	970	16.40	5.66	16.27	7.46	16.07	8.95	15.79	10.10	15.44	11.70	15.02	13.20	14.78	14.56	14.49	15.80	14.15	16.90	13.75	18.23	13.30	19.50		
	1110	18.77	7.36	18.62	9.09	18.38	10.81	18.07	12.80	17.67	14.14	17.18	15.65	16.91	17.28	16.58	18.59	16.19	19.89	15.73	21.15	15.22	22.65		
	1180	19.95	8.07	19.79	9.93	19.54	11.71	19.21	13.76	18.78	15.37	18.27	16.73	17.98	18.43	17.63	19.80	17.21	21.12	16.73	22.55	16.18	23.84		
	1240	20.97	8.72	20.80	10.55	20.54	12.50	20.18	14.62	19.74	16.32	19.20	17.69	18.90	19.38	18.53	20.93	18.09	22.23	17.58	23.96	17.00	25.13		
	1400	23.67	10.43	23.48	12.49	23.19	14.50	22.79	16.87	22.28	18.64	21.67	20.24	21.33	22.03	20.92	23.84	20.42	25.75	19.85	27.32	19.19	28.97		

MODEL ARC 200X	RPM	Discharge Pressure (kgf/cm ²)																							
		0.10		0.15		0.20		0.25		0.30		0.35		0.40		0.45		0.50		0.55		0.60			
		9.8kPa		14.7kPa		19.6kPa		24.5kPa		29.4kPa		34.4kPa		39.2kPa		44.1kPa		49kPa		53.9kPa		58.8kPa			
		Qs	La	Qs	La	Qs	La	Qs	La	Qs	La	Qs	La	Qs	La	Qs	La	Qs	La	Qs	La	Qs	La	Qs	La
SIZE 200	810	31.77	8.05	31.19	11.28	30.52	14.65	29.98	17.60	29.55	20.68	29.21	23.83	28.89	26.94	28.57	29.22	28.22	33.16	27.91	36.05	27.63	39.05		
	900	35.68	9.95	35.05	13.48	34.49	17.10	34.04	20.44	33.66	24.00	33.36	27.53	33.05	30.93	32.73	34.40	32.34	37.83	32.03	41.02	31.71	44.38		
	980	39.15	11.58	38.53	15.50	38.08	19.38	37.66	22.93	37.34	27.18	37.05	30.78	36.77	34.55	36.41	38.23	36.03	42.02	35.68	45.52	35.34	49.38		
	1070	43.03	13.46	42.50	17.81	42.4	21.24	41.68	25.82	41.44	30.13	41.17	34.43	40.97	38.88	40.56	42.65	40.15	46.82	39.77	50.71	39.42	54.95		
	1150	46.50	15.18	46.04	19.95	45.55	23.71	45.31	28.13	45.07	32.71	44.85	37.26	44.60	42.02	44.21	46.62	43.78	50.98	43.42	55.09	43.06	59.74		
	1230	49.60	17.09	49.16	21.94	48.74	26.43	48.45	31.28	48.22	36.26	48.00	41.25	47.78	46.08	47.49	50.78	47.08	55.53	46.76	59.83	46.44	64.80		
	1310	52.67	19.65	52.22	24.34	51.86	29.20	51.57	34.28	51.38	39.66	51.18	44.88	50.99	50.18	50.69	55.09	50.40	59.96	50.10	64.53	49.83	69.72		
	1390	55.77	21.31	54.31	26.64	54.96	31.88	54.72	37.46	54.49	42.92	54.35	48.52	54.16	54.22	53.91	59.28	53.68	64.48	53.49	69.16	53.24	74.60		
	1480	59.20	23.80	58.83	28.96	58.46	34.37	58.24	40.42	58.02	46.58	54.89	52.36	57.76	58.19	57.57	63.62	57.37	68.88	57.22	74.22	57.08	80.18		

Note for the performance table

1. Air volume listed in the table (hereafter referred to as listed air volume) represents a suction air volume at the standard suction state (temperature 20 °C, absolute pressure 10332 mmAq (1013m bar), relative humidity 65%).
2. Air volume at standard conditions (0 °C, 10332 mmAq. Abs.) can be converted into listed air volume by the following formula:

$$Q_s = Q_N \times \frac{10332}{10332 + P_s} \times \frac{273 + t_s}{273} \quad (1)$$

Air volume at discharge state can be converted into listed air volume by the following formula:

$$Q_s = Q_d \times \frac{10332 + P_d}{10332} \times \frac{273 + t_s}{273 + t_d} \quad (2)$$

Where:

Q _s :	Listed air volume	(m ³ /min)
Q _N :	Air volume at standard condition	(m ³ /min)
Q _d :	Air volume at discharge state	(mmAq G)
p _s :	Suction pressure	(mmAq G)
p _d :	Discharge pressure	(°C)
t _s :	Suction temperature	(°C)
t _d :	Discharge temperature	

3. Between two adjacent blower models, air volumes at boundary level overlap. Either of the two models can be used, but, from the economical standpoint it is recommended that smaller model is used. Occasionally, however, a larger model is used at low speed in consideration of noise level. Please refer to noise data given in this catalogue, if this is being considered.
4. Shaft horse power listed in the performance table is a required horse power, including the power requirements for transmission (V Belt). Motor with an output corresponding to the listed shaft horse power can be used. However, it will be better to use motors, of which the outputs are 5 - 10% larger than shaft horse powers. The use of an excessively larger motor would result in unnecessary energy waste, as no load current will increase, causing the motor efficiency to drop.
5. The number of revolutions of each type in the performance table is shown by the standard rpm (common to 50 Hz, 60 Hz) that can be obtained by combining a 4-pole motor and a JIS V-pulley. Use this standard rpm unless otherwise required.
6. This three lobe rotary blower can be used as a dry type vacuum pump for a vacuum up to 5,000 mmAq. Please refer to the table in the next page.

To use the formula (2) for conversion, it is necessary to assume a discharge temperature. Discharge temperature of air

right after being discharged can be obtained in approximate value by the following formula.

$$t_d \approx t_s + p_d / 100 \quad (3)$$

where, t_s represents suction temperature between 0 and 40 °C.

Installation Guides

Blower operation

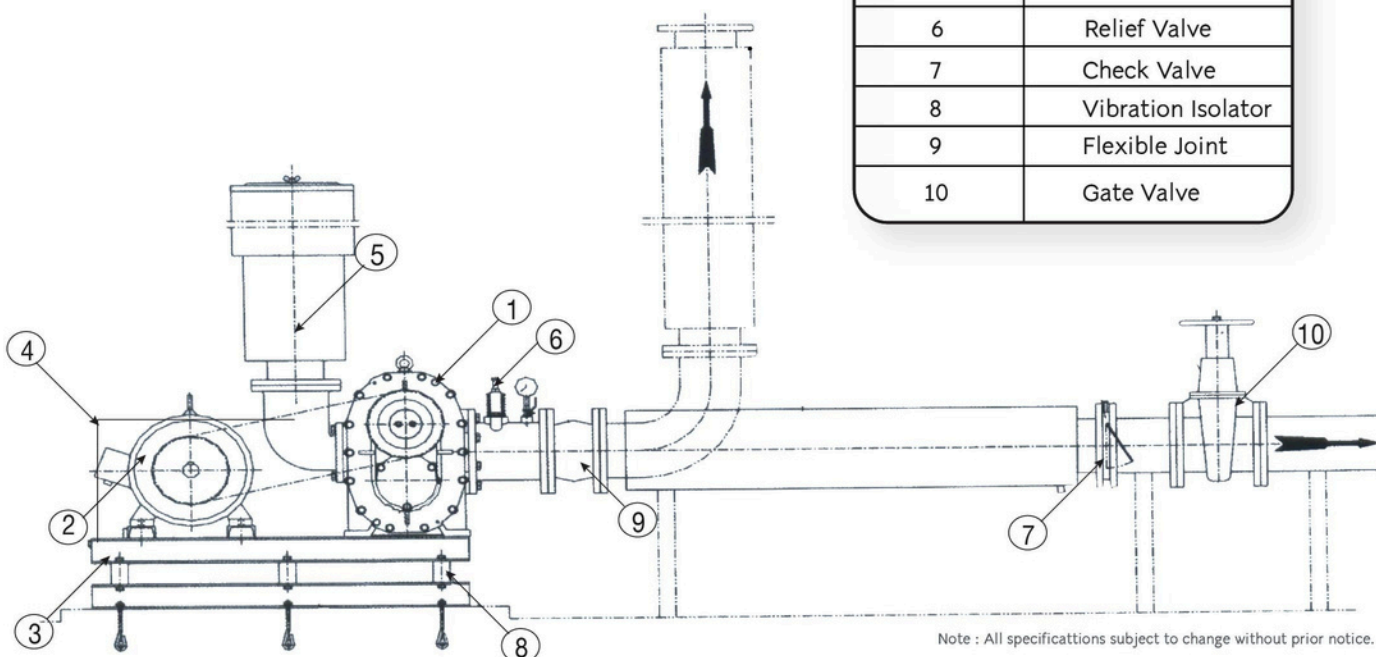

No.	Part Name
1	Rotary Blower
2	Motor
3	Common Base
4	Belt Guard
5	Suction Siencer
6	Relief Valve
7	Check Valve
8	Vibration Isolator
9	Flexible Joint
10	Gate Valve

Note : All specifications subject to change without prior notice.

DIMENSION

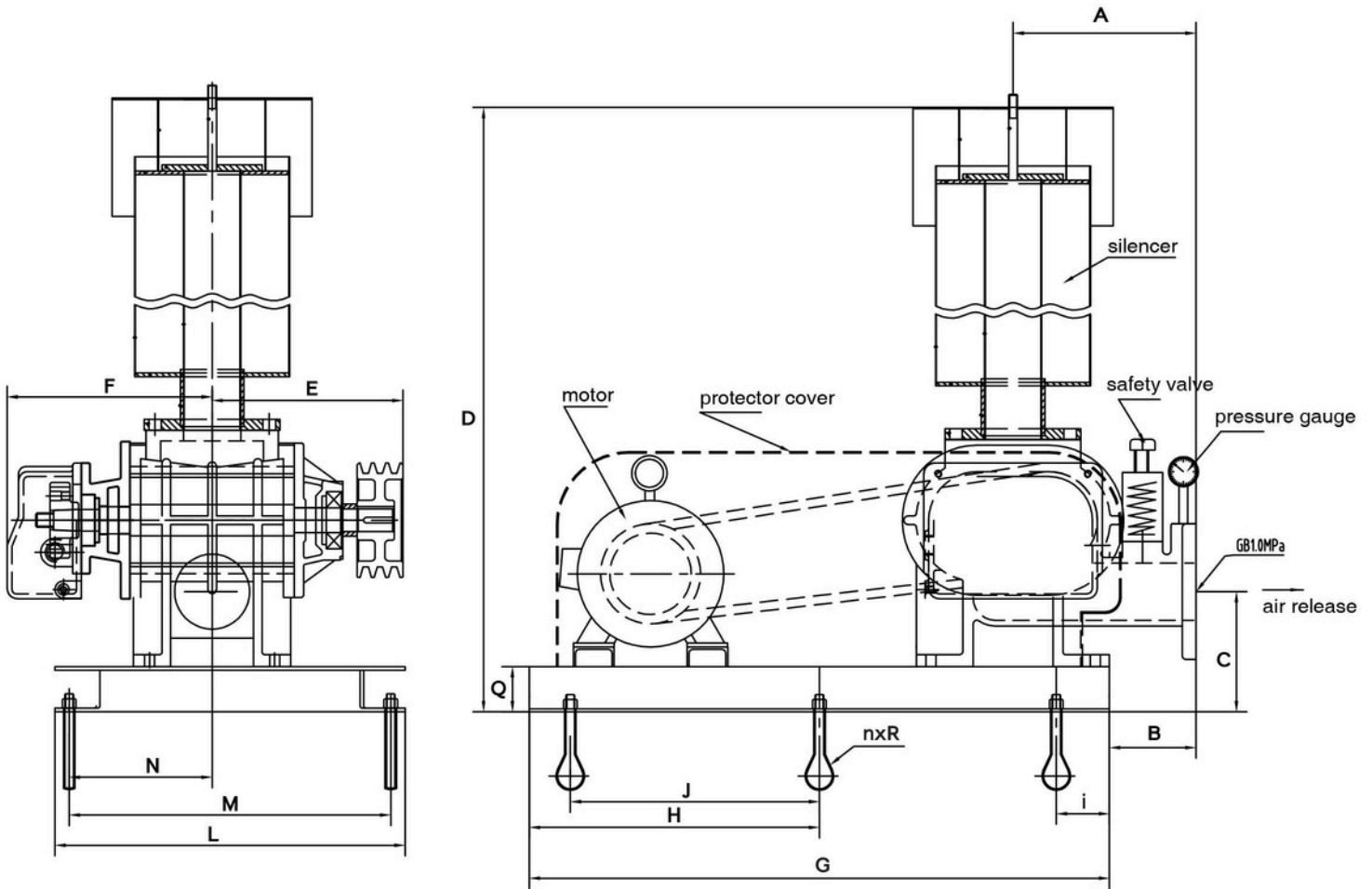

MODEL ARC	BORE	DIMENSION														WEIGHT	
		A	B	C	D	E	F	G	H	I	J	L	M	N	Q	nxR	Kg
32x	32	90	25	132	370	112.5	162.5	500	400	50	ZG1-1/4"	254	210	95	50	4xM8	42
40X	40	110	37.5	154	410	150	190	500	400	50	ZG1-1/2"	315	280	125	50	4xM10	70
50X	50	193	97	100	414	168	166	640	320	-	---	380	340	167	50	2xM10	40
65X	65	253	143	158	510	215	210	660	330	-	---	450	410	220	63	2xM10	65
80X	80	255	121	168	1046	267	287	812	406	-	---	490	434	230	63	2xM12	125
100X	100	213	85	238	1048	316	352	812	406	-	---	585	529	222	63	2xM12	175
125X	125	375	205	323	1508	346	370	900	450	100	350	700	640	275	63	6xM16	360
150X	150	375	205	323	1623	386	409	1000	500	100	400	700	640	230	63	6xM16	400
200X	200	350	250	250	2210	595	510	1400	525	25	500	200	1000	500	120	4xM16	630