



















# Coolant Pumps General Catalog

**TERAL**

50Hz/60Hz



Coolant Pumps  
General Catalogue

		Features	Specifications	General Concept Chart for Use in Selecting Products	
		P.3	P.4	P.5	
Immersion type	Low head / Low-Medium flow	<b>VKP model</b>  P.6	<b>VKP-H model</b>  P.10		
	Medium head / Low flow	<b>LHW model</b>  P.12	<b>VKR model</b>  P.14	<b>VKA-AH model</b>  P.17	<b>VKA-AQ model</b>  P.20
		<b>VKC-AH model</b>  P.23	<b>VKC-AQ model</b>  P.26		
	Low head / Medium-High flow	<b>LFE model</b>  P.29			
	Medium head / Medium-High flow	<b>LFO model</b>  P.31			
	Medium head / Medium-High flow	<b>VKD model</b>  P.35	<b>LPW model</b>  P.40		
		High head / Low-Medium flow	<b>LKW model</b>  P.46	<b>VKB-H model</b>  P.49	<b>VKB-Q model</b>  P.57
Self-priming floor type	Low head / Low-Medium flow	<b>VKN-A model</b>  P.63	<b>VKN-H model</b>  P.66		
	Medium head / Medium-High flow	<b>LPS model</b>  P.68			
Immersion type	Coolant for tank cleaning	<b>SKM model</b>  P.74			
		<b>Selection Guide</b>	<b>Handling Precautions</b>		
		P.75	P.76		

## Extensive product lineup

Immersion type

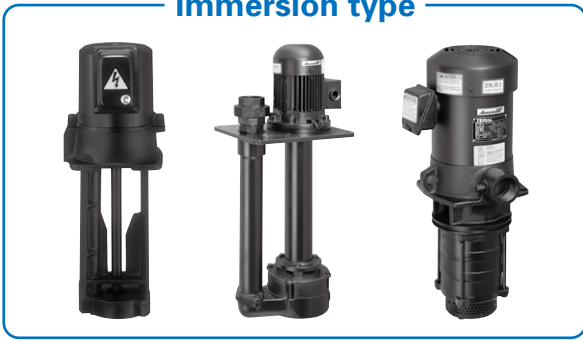

Floor type (Self-priming type)



For tank cleaning



### Mechanical sealing type

※High efficiency due to no leakage

### Non-seal (mechanical seal-less) type

※Not easily affected by chips, can be used for dirty coolants.

**TERAL' s original non-seal structure allows coolant to flow from a narrow clearance without using a seal between the pump section and motor section.**

Many advantages that only non-seal pumps can provide

**1** No coolant leakage or other problems.

Helps cut down running costs.

**2** No need for a safety valve, escape piping, or a three-way valve.

Helps cut down initial costs.

**3** Prevents air accumulation.

Reduces initial trouble.

**4** Capable of serial running

A series of volute pumps can generate up to 3.92MPa (40kgf/cm<sup>2</sup>).

**5** Not easily affected by small quantity of liquid or shut-off operation.

Build the pump system you want.

**6** Not easily affected by chips

Can be used for dirty coolants.

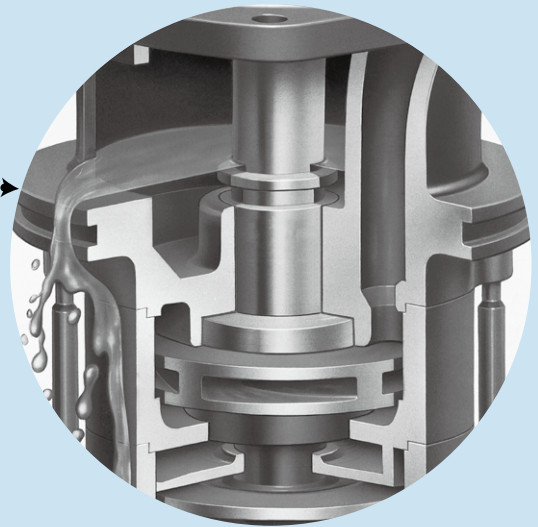
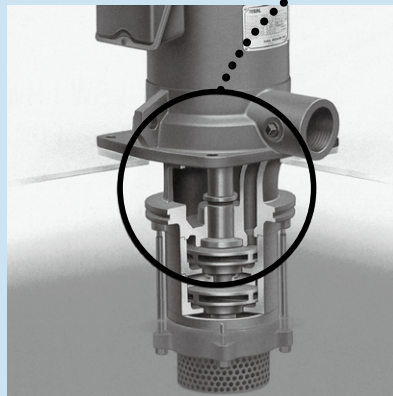

※What is the non-seal structure?

This structure releases coolant by depressurizing through a narrow clearance. No mechanical seal is used.

Type	Model	Installation	Suction	Impeller		Discharge casing material	Interim casing guide vane material	Diameter (mm)	Frequency	Typical discharge rate <sup>*1</sup> (ℓ/min)	Max. head <sup>*1</sup> (m)	Output (kW)	Phase (P)	Model number	Remarks
				Q'ty	Material										
Single-stage immersion type / Low-Medium flow / Low head	VKP model	Immersion type	Non-self-priming type	Single-stage	Resin or CAC407	FC150	—	8A ~ 50A	50Hz	13 ~ 165	7	0.02 ~ 0.75	2	27	CE marking
									60Hz	19 ~ 285	7	0.02 ~ 0.75	2	25	CE marking
	VKP-H model	Immersion type	Non-self-priming type	Single-stage	Resin or CAC407	FC150	—	10A ~ 25A	50Hz	10 ~ 20	13	0.06 ~ 0.4	2	5	CE marking
									60Hz	10 ~ 20	18	0.06 ~ 0.4	2	5	CE marking
Multi-stage immersion type / Low flow / Medium head	LHW model	Immersion type	Non-self-priming type	Multi-stage	Resin	FC200	Resin	20A	50Hz	20 ~ 80	50	0.75 ~ 1.1	2	4	CE marking
									60Hz	20 ~ 90	73	0.75 ~ 1.1	2	4	CE marking
	VKR model	Immersion type	Non-self-priming type	Multi-stage	Resin	FC150	Resin	20A	50Hz	20 ~ 30	60	0.4 ~ 2.2	2	5	CE marking
									60Hz	20 ~ 30	90	0.4 ~ 2.2	2	5	CE marking
	VKA-AH model	Immersion type	Non-self-priming type	Multi-stage	SUS304	FC150/FC200	SUS304	20A, 32A	50Hz	40	63	0.1 ~ 0.9	2	39	CE marking
									60Hz	50	86	0.17 ~ 1.53	2	39	CE marking
	VKA-AQ model	Immersion type	Non-self-priming type	Multi-stage	SUS304	FC150/FC200	SUS304	20A, 32A	50Hz	85	39	0.18 ~ 1.1	2	29	CE marking
									60Hz	100	54	0.3 ~ 1.8	2	29	CE marking
	VKC-AH model	Immersion type	Non-self-priming type	Multi-stage	SUS304	SCS	SUS304	20A	50Hz	40	48	0.1 ~ 0.7	2	36	CE marking
									60Hz	50	62	0.17 ~ 1.19	2	36	CE marking
	VKC-AQ model	Immersion type	Non-self-priming type	Multi-stage	SUS304	SCS	SUS304	20A	50Hz	85	26	0.18 ~ 0.72	2	17	CE marking
									60Hz	100	36	0.3 ~ 1.2	2	17	CE marking
Single-stage immersion type / Medium-High flow / Low head	LFE model <sup>*2</sup>	Immersion type	Non-self-priming type	Single-stage	FCD450	FC200	—	32A ~ 65A	60Hz	60 ~ 430	8	0.25 ~ 0.75	2	5	
Single-stage immersion type / Medium-High flow / Medium head	LFO model <sup>*2</sup>	Immersion type	Non-self-priming type	Single-stage	FCD450	FC200	—	50A ~ 80A	50Hz	100 ~ 750	24	0.75 ~ 5.5	2	22	
									60Hz	100 ~ 900	36	0.75 ~ 5.5	2	20	
Multi-stage immersion type / Medium-High flow / Medium head	VKD model	Immersion type	Non-self-priming type	Multi-stage	FC200	FC200	FC200	40A, 50A	50Hz	80 ~ 400	40	0.75 ~ 3.0	2	21	CE marking
									60Hz	100 ~ 500	54	0.75 ~ 3.0	2	7	CE marking
	LPW model <sup>*2</sup>	Immersion type	Non-self-priming type	Multi-stage	FCD450	FC200	FC200	40A, 65A	50Hz	50 ~ 700	63	0.75 ~ 7.5	2	20	
									60Hz	60 ~ 750	64	0.75 ~ 7.5	2	8	
Multi-stage immersion type / Low-Medium flow / High head	LKW model	Immersion type	Non-self-priming type	Multi-stage	Resin	FC200	Resin (+SUS304)	20A	50Hz	20 ~ 70	400	2.0 ~ 4.0x2	2	5	
									60Hz	20 ~ 70	400	2.0 ~ 4.0x2	2	5	
	VKB-H model	Immersion type	Non-self-priming type	Multi-stage	SUS304	FC200	SUS304	32A	50Hz	40	114	0.5 ~ 1.9	2	217	
									60Hz	50	152	0.85 ~ 3.23	2	99	
	VKB-Q model	Immersion type	Non-self-priming type	Multi-stage	SUS304	FC200	SUS304	32A	50Hz	85	78	0.72 ~ 2.34	2	158	
									60Hz	100	108	1.2 ~ 3.6	2	77	
Single-stage self-priming type / Low-Medium flow / Low head	VKN-A model	Floor type	Self-priming type	Single-stage	Resin or CAC407	FC150	—	8A ~ 40A	50Hz	13 ~ 230	7	0.04 ~ 0.75	2	17	CE marking
									60Hz	16 ~ 320	7	0.04 ~ 0.75	2	15	CE marking
	VKN-H model	Floor type	Self-priming type	Single-stage	Resin or CAC407	FC150	—	10A ~ 25A	50Hz	10 ~ 20	12	0.06 ~ 0.4	2	5	CE marking
									60Hz	10 ~ 20	17	0.06 ~ 0.4	2	5	CE marking
Multi-stage self-priming type / Medium-High flow / Medium head	LPS model <sup>*2</sup>	Floor type	Self-priming type	Multi-stage	FCD450	FC200	FC200	40A, 65A	50Hz	50 ~ 650	62	0.75 ~ 7.5	2	20	
									60Hz	50 ~ 700	64	0.75 ~ 7.5	2	8	
Single-stage immersion type / Low flow / Low head (for cleaning coolant tank)	SKM model	Immersion type	Non-self-priming type	Single-stage	SUS304	FC150	—	20A	50Hz	50	6	0.25	2	1	
									60Hz	50	9	0.25	2	1	

※1: Typical performance data. See concept chart for use in selecting products and specification list of each model for detailed performance.

※2: Structure based on FCD 450 for impeller and FC200 for casings that allows application for turbid liquid.



### 50Hz

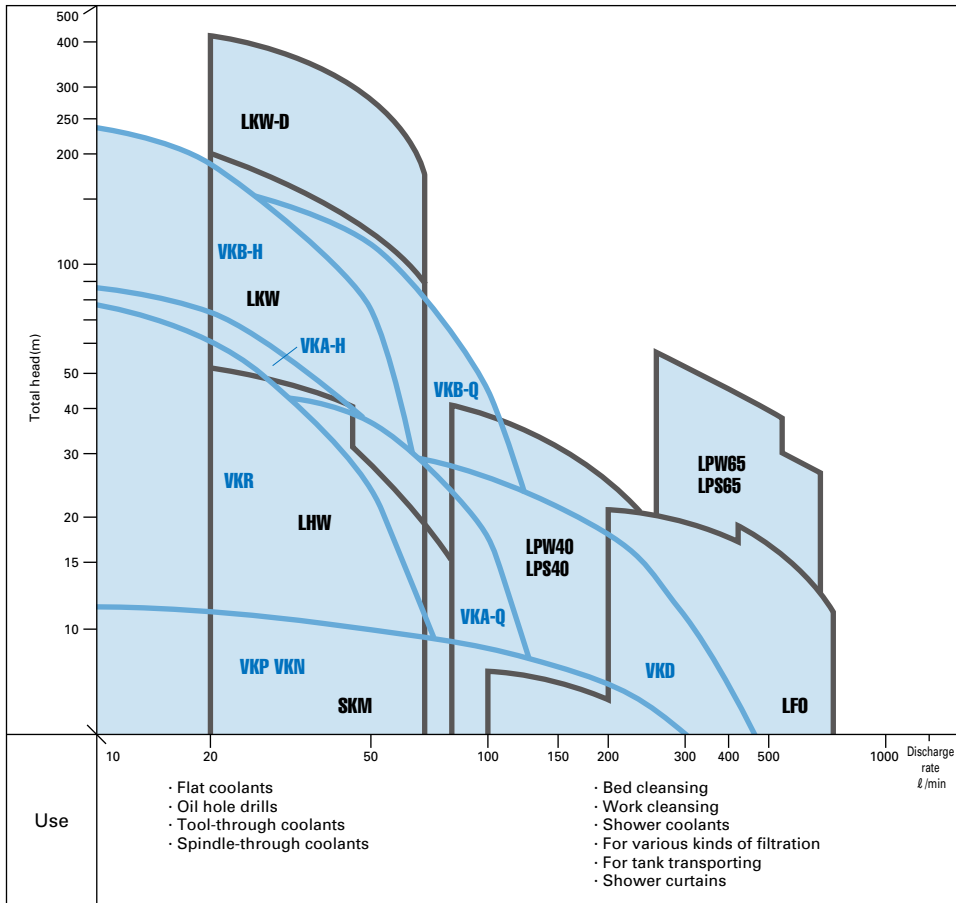

To choose a model, refer to the performance drawings on the corresponding pages.

### 60Hz

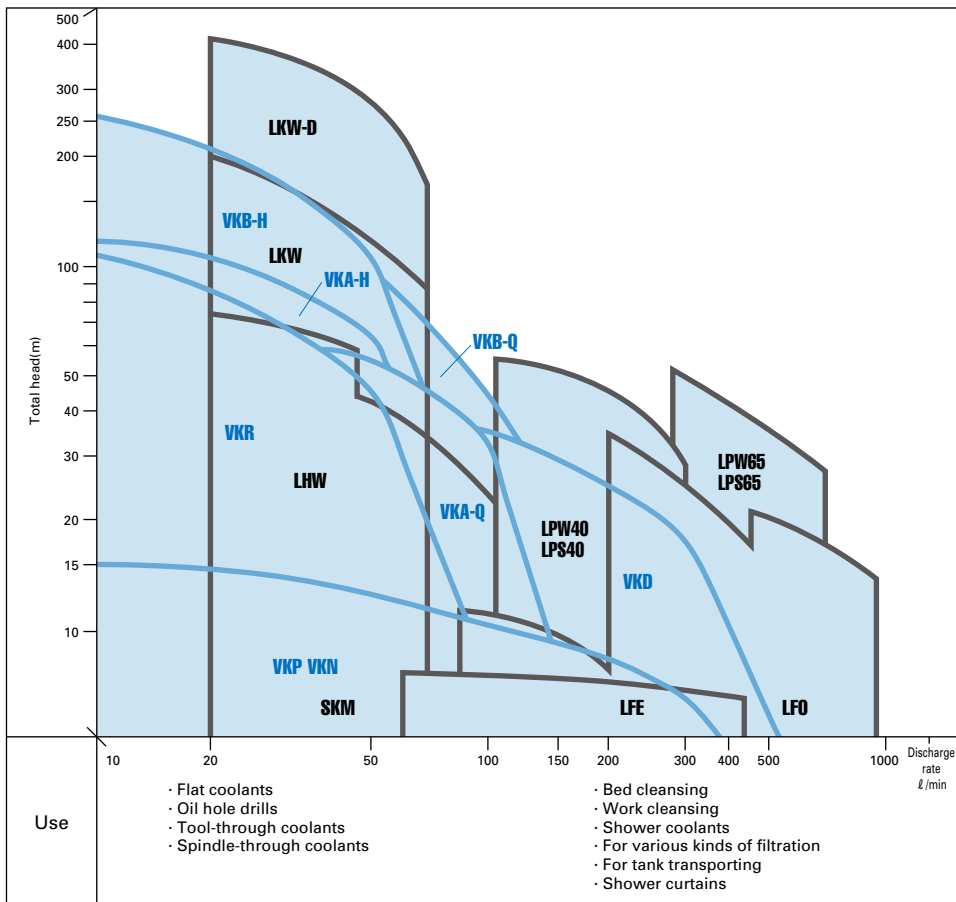

To choose a model, refer to the performance drawings on the corresponding pages.

**Features**

- ① The pump is immersed in the liquids when in use
- ② Long and short-leg types available to suit various tank depths
- ③ EU RoHS Directive (Restriction of Use of Six Hazardous Substances) compliant
- ④ Meets the EU Directive for CE marking
- ⑤ China energy label regulation (GB18613-2012) efficiency-compliant unit (grade GB3) available
- ⑥ Enhanced protection against mist and other environmental elements

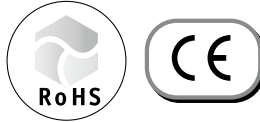

**Structure**

Non-seal (mechanical seal-less) structure. Cast iron is used in the pump's main unit.

**How to read the model type**

**VKP 07 5**

- ①
- ②
- ③
- ④
- ⑤
- ⑥

- ① Model
  - ② Output code(ex. 06: 100W)
  - ③ Series
  - ④ Number of phases and characteristics
  - ⑤ Leg length\*(F: 180mm; H: 250mm; K: 350mm)
  - ⑥ Compliance with voltage/energy efficiency regulation (no description: standard; 4Z: different voltage  
-G: China energy label regulation (GB18613-2012) efficiency-compliant unit (grade GB3) (200V, 50Hz)  
-GS: China energy label regulation (GB18613-2012) efficiency-compliant unit (grade GB3) (220/380V, 50Hz)
- \*Note: For VKP07~09 types only

**Selection chart (performance drawings)**

**VKP035L**

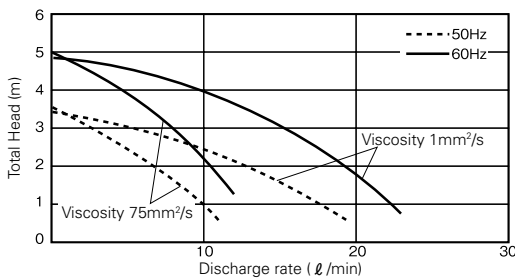

**VKP045A (L)**

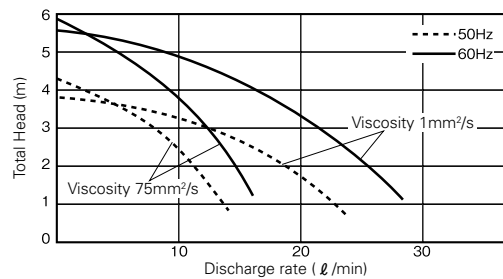

**VKP055A/055A-4Z**

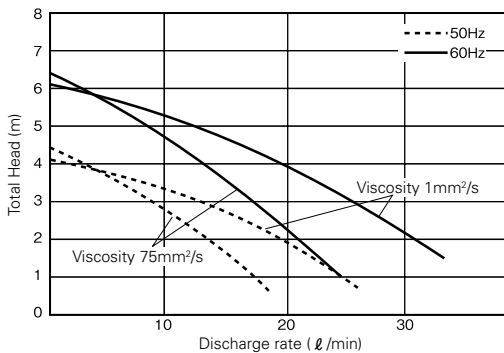

**VKP065A/065A-4Z**

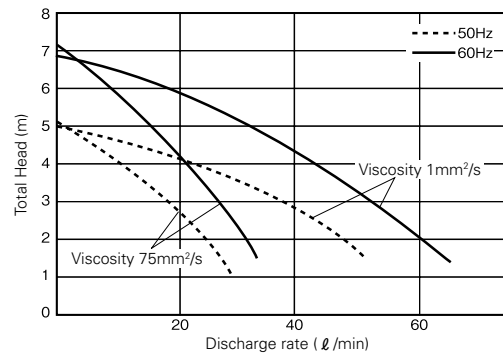

**VKP075A/075A-4Z/075J/075AH/075AK**

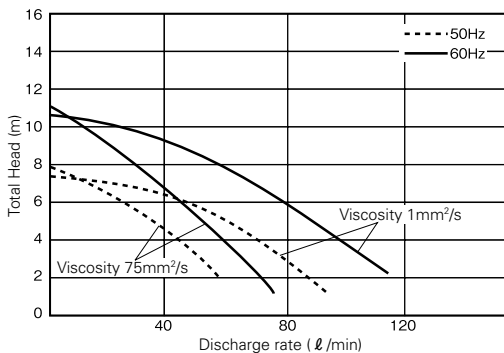

**VKP085A/085A-4Z/085J/085AF/085AK**

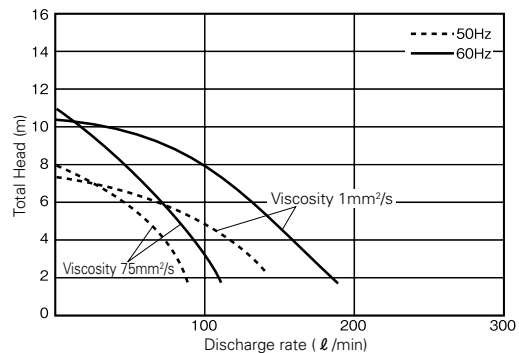

Notes 1. The discharge rate will vary significantly depending on the type of liquid circulated and the liquid's viscosity.  
2. There is virtually no change in characteristics according to leg length (LH130 to 350mm).

### Selection chart (performance drawings)

**VKP095A/095A-4Z/095J/095AF/095AK**

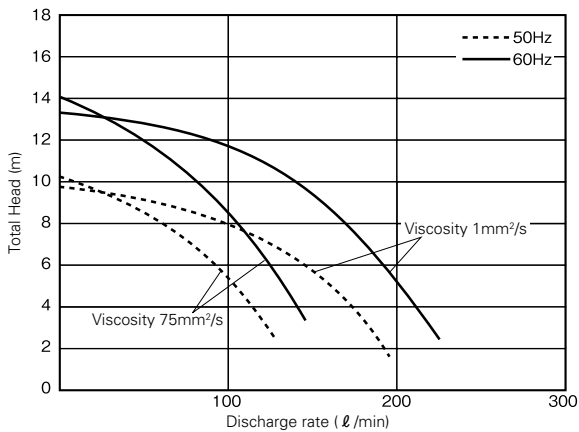

**VKP115A/115A-4Z/115A-G/115A-GS**

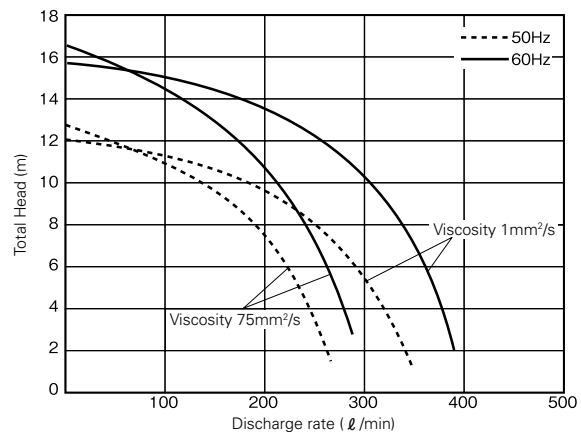

Notes 1. The discharge rate will vary significantly depending on the type of liquid circulated and the liquid's viscosity.  
2. There is virtually no change in characteristics according to leg length (LH130 to 350mm).

### Specifications

#### Standard voltage

Specifications	Type	VKP035L*	VKP045A(L)*	VKP055A	VKP065A	VKP075A(AH)(AK)	VKP075J	VKP085A(AK)	VKP085J	VKP095A(AK)	VKP095J	VKP115A
Nominal output	(W)	20	40	60	100	180	180	250	250	400	400	750
Rated voltage	(V)	200 200 220	200 200 220	200 200 220	200 200 220	200 200 220	200 200 220	200 200 220	200 200 220	200 200 220	200 200 220	200 200 220
Frequency	(Hz)	50	60	50	60	50	60	50	60	50	60	50
Rated current	(A)	0.18 0.2 0.2	0.32 0.31 0.31	0.4 0.35 0.35	0.55 0.5 0.5	0.85 1.0 1.0	0.85 1.0 1.0	1.2 1.5 1.5	1.2 1.5 1.5	2.4 2.5 2.4	2.4 2.5 2.4	3.3 2.5 3.6
Discharge rate	(l/min)	13	19	19	25	20	30	45	60	75	100	75
Total head	(m)	2	1.5	2	2	3	3	4	4	5	5	7
Max. viscosity allowed	(mm²/s)	300	150	300	150	300	150	300	150	300	150	300
Outlet	(Rp)	1/4	1/4	3/8	3/8	1/2	1/2	3/4	3/4	1	1	2
Paint color		Munsell N1										
Standard		IEC60034-1 CE approved										
Degree of protection		IP23		IP54								

#### Different voltage

Specifications	Type	VKP045A-4Z	VKP055A-4Z	VKP065A-4Z	VKP075A-4Z	VKP085A-4Z	VKP095A-4Z	VKP115A-4Z
Nominal output	(W)	40	60	100	180	250	400	750
Rated voltage	(V)	380 400 415	400 400 415	400 400 415	380 400 415	400 400 415	380 400 415	400 400 415
Frequency	(Hz)	50	60	50	60	50	60	50
Rated current	(A)	0.16 0.16 0.17	0.16 0.16 0.16	0.19 0.20 0.22	0.18 0.18 0.18	0.28 0.28 0.29	0.25 0.25 0.25	0.44 0.43 0.42
Discharge rate	(l/min)	19	25	20	30	45	60	75
Total head	(m)	1.5	2	2	3	4	5	7
Max. viscosity allowed	(mm²/s)	300	150	300	150	300	150	300
Outlet	(Rp)	1/4	3/8	3/8	1/2	3/4	1	2
Paint color		Munsell N1						
Standard		IEC60034-1 CE approved						
Degree of protection		IP54						

#### China energy label regulation (GB18613-2012) efficiency-compliant unit (grade GB3)

Specifications	Type	VKP115A-G	VKP115A-GS
Nominal output	(W)	750	750
Rated voltage	(V)	200	220 380
Frequency	(Hz)	50	
Rated current	(A)	3.3	3.1 1.8
Discharge rate	(l/min)	165	
Total head	(m)	7	
Max. viscosity allowed	(mm²/s)	300	
Outlet	(Rp)	2	
Paint color		Munsell N1	
Standard		IEC60034-1 CE approved	
Degree of protection		IP44	

Notes 1. As the pump whose model number has a suffix L (with marked ★) has cabytre leads, it does not conform to CE marking and its degree of protection is IP23.  
2. The discharge rate and total head values were obtained in tests with a liquid viscosity of 1mm²/s (same as tap water at normal temperature). Note that the pumps cannot be used with water.  
3. VKP□□J and VKP115A are bottom suction types.

Assembly Drawing

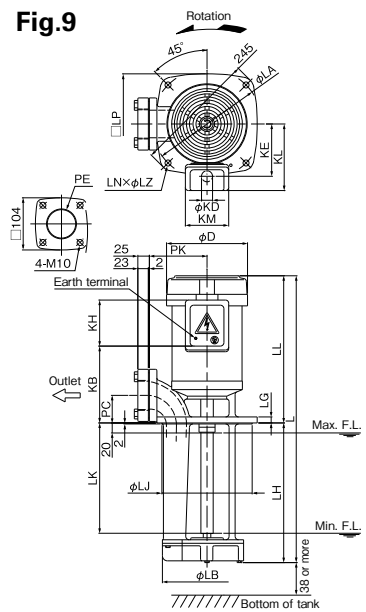
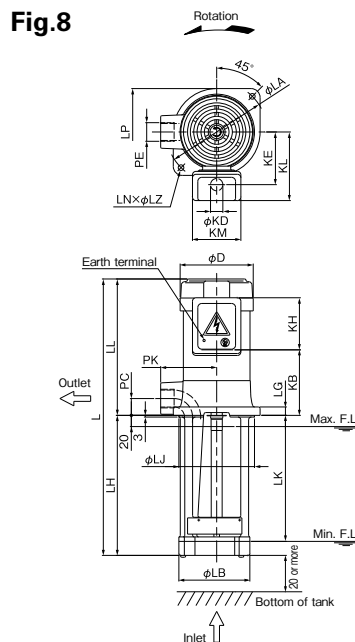
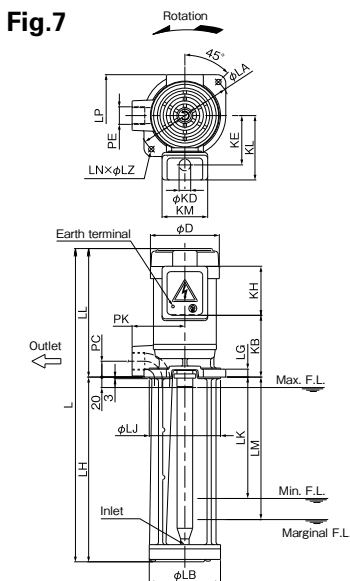
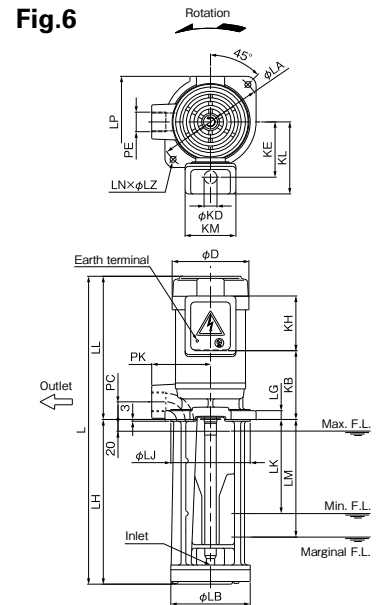
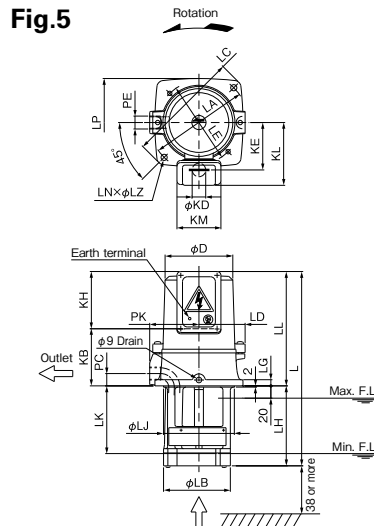
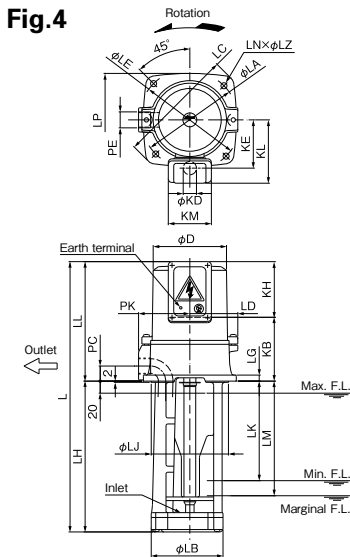
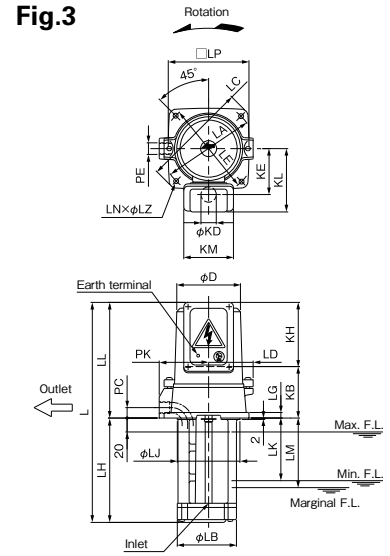
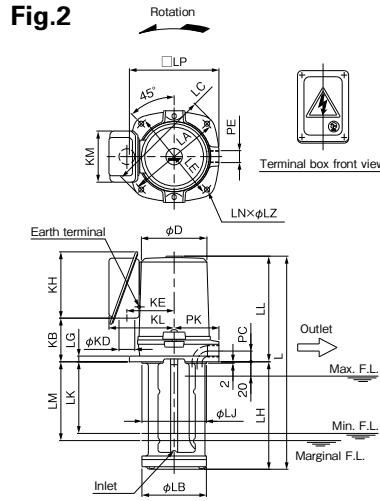
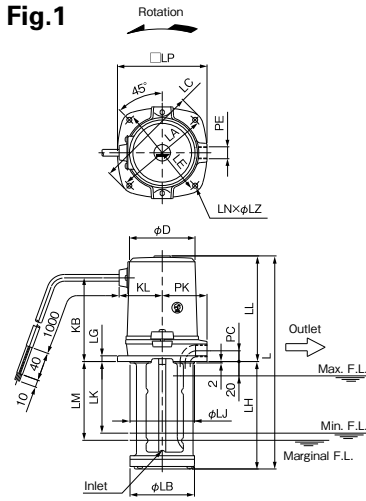

### Dimensions

(Unit : mm)

Type	Fig.	D	KB	KD	KE	KH	KL	KM	L	LA	LB	LC	LD	LE	LG	LH	LJ	LK	LL	LM	LN	LP	LZ	PC	PE	PK	Approx. mass (kg)
VKP035L	1	92	115.5	—	—	—	61	—	296	130	90 <sup>0</sup> <sub>-0.5</sub>	143	—	130	8	148	90 <sup>0</sup> <sub>-0.5</sub>	105	148	115	4	125	7	15	Rp¼	62.5	5.5
VKP045L	1	92	115.5	—	—	—	61	—	298	130	90 <sup>0</sup> <sub>-0.5</sub>	143	—	130	8	150	90 <sup>0</sup> <sub>-0.5</sub>	100	148	110	4	125	7	15	Rp¼	62.5	5.5
VKP045A(-4Z)	2	92	60.5	22	67	93	93	73	298	130	90 <sup>0</sup> <sub>-0.5</sub>	145	—	130	8	150	90 <sup>0</sup> <sub>-0.5</sub>	100	148	110	4	125	7	15	Rp¼	62.5	5.5
VKP055A(-4Z)	3	92	74	22	67	93	93	73	317	132	90 <sup>0</sup> <sub>-0.5</sub>	152	64	130	8	150	90 <sup>0</sup> <sub>-0.5</sub>	100	167	110	4	116	7	15	Rp¾	71	6.0
VKP065A(-4Z)	3	92	74	22	67	93	93	73	317	132	90 <sup>0</sup> <sub>-0.5</sub>	152	64	134	8	150	90 <sup>0</sup> <sub>-0.5</sub>	90	167	100	4	116	7	15	Rp¾	71	6.5
VKP075A(-4Z)	3	111	94	22	78	93	104	73	367	160	115 <sup>0</sup> <sub>-0.5</sub>	184	75	134	10	180	115 <sup>0</sup> <sub>-0.5</sub>	105	187	130	2 <sup>0</sup> <sub>-0.2</sub>	143	10 <sup>0</sup> <sub>-0.1</sub>	20	Rp½	80	10.0
VKP075J	5	111	94	22	78	93	104	73	317	160	115 <sup>0</sup> <sub>-0.5</sub>	184	75	134	10	130	115 <sup>0</sup> <sub>-0.5</sub>	110	187	110	2 <sup>0</sup> <sub>-0.2</sub>	143	10 <sup>0</sup> <sub>-0.1</sub>	20	Rp½	80	11.0
VKP075AH	3	111	94	22	78	93	104	73	437	160	115 <sup>0</sup> <sub>-0.5</sub>	184	75	134	10	250	115 <sup>0</sup> <sub>-0.5</sub>	175	187	200	2 <sup>0</sup> <sub>-0.2</sub>	143	10 <sup>0</sup> <sub>-0.1</sub>	20	Rp½	80	10.0
VKP075AK	3	111	107	22	78	93	104	73	550	160	115 <sup>0</sup> <sub>-0.5</sub>	184	75	134	10	350	115 <sup>0</sup> <sub>-0.5</sub>	275	200	300	2 <sup>0</sup> <sub>-0.2</sub>	143	10 <sup>0</sup> <sub>-0.1</sub>	20	Rp½	80	11.0
VKP085A(-4Z)	4	122	106	22	81	93	107	73	449	160	128 <sup>0</sup> <sub>-0.5</sub>	194	80	170	10	250	128 <sup>0</sup> <sub>-0.5</sub>	165	199	190	4	154	10	25	Rp¾	85	15.0
VKP085J	5	122	106	22	81	93	107	73	329	160	128 <sup>0</sup> <sub>-0.5</sub>	194	80	170	10	130	128 <sup>0</sup> <sub>-0.5</sub>	105	199	—	4	154	10	25	Rp¾	85	16.0
VKP085AF	3	122	106	22	81	93	107	73	379	160	128 <sup>0</sup> <sub>-0.5</sub>	194	80	170	10	180	128 <sup>0</sup> <sub>-0.5</sub>	95	199	120	4	154	10	25	Rp¾	85	15.0
VKP085AK	3	122	116	22	81	93	107	73	559	160	128 <sup>0</sup> <sub>-0.5</sub>	194	80	170	10	350	128 <sup>0</sup> <sub>-0.5</sub>	265	209	290	4	154	10	25	Rp¾	85	16.0
VKP095A(-4Z)	6	131	117	22	94	93	122	87	524	180	135 <sup>0</sup> <sub>-0.7</sub>	—	—	—	15	280	135 <sup>0</sup> <sub>-0.7</sub>	160	244	200	2	155	10	30	Rp1	100	16.5
VKP095J	8	131	117	22	94	93	122	87	494	180	135 <sup>0</sup> <sub>-0.7</sub>	—	—	—	15	250	135 <sup>0</sup> <sub>-0.7</sub>	225	244	—	2	155	10	30	Rp1	100	17.0
VKP095AF	7	131	117	22	94	93	122	87	424	180	135 <sup>0</sup> <sub>-0.7</sub>	—	—	—	15	180	135 <sup>0</sup> <sub>-0.7</sub>	60	244	100	2	155	10	30	Rp1	100	17.0
VKP095AK	7	131	117	22	94	93	122	87	594	180	135 <sup>0</sup> <sub>-0.7</sub>	—	—	—	15	350	135 <sup>0</sup> <sub>-0.7</sub>	230	244	270	2	155	10	30	Rp1	100	18.0
VKP115A(-4Z)	9	162	152	22	105	93	133	87	565	220	180 <sup>0</sup> <sub>-0.7</sub>	—	—	—	12	280	180 <sup>0</sup> <sub>-0.7</sub>	220	285	—	4	200	12	55	Rp2	115	29.0
VKP115A-G	9	162	152	22	105	93	133	87	565	220	180	—	—	—	12	280	180 <sup>0</sup> <sub>-0.7</sub>	220	285	—	4	200	12	55	Rp2	115	29.0
VKP115A-GS	9	162	152	27	108	93	146	94	565	220	180	—	—	—	12	280	180 <sup>0</sup> <sub>-0.7</sub>	220	285	—	4	200	12	55	Rp2	115	29.0

### Sectional drawing

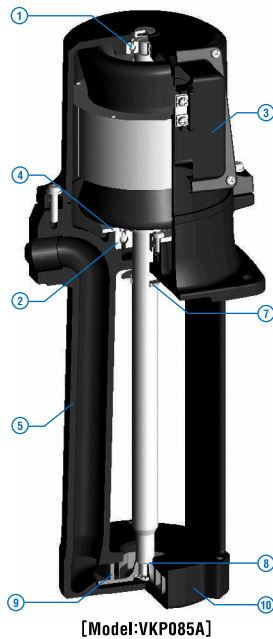

No.	Parts Name	Materials
1	Deep groove ball bearing	
2	Deep groove ball bearing	
3	Terminal box	SPCC
4	End cover	SPHC
5	Pump leg	FC150
7	Oil thrower	SPCC
8	Adjusting washer	BsP3-1 / 2H
9	Impeller	Special resins or CAC407
10	Eddy box	FC150

Note: Structure and other details are subject to change without notice.



**Features**

- ① About 30% pressure level increase compared with the standard type
- ② The pump is immersed in the liquids when in use
- ③ EU RoHS Directive  
(Restriction of Use of Six Hazardous Substances)compliant
- ④ Meets the EU Directive for CE marking
- ⑤ Enhanced protection against mist and other environmental elements

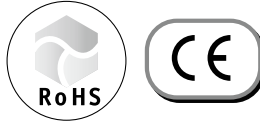

**Structure**

Non-seal (mechanical seal-less) structure. Cast iron is used in the pump's main unit.

**How to read the model type**

**VKP 07 5 H**

①      ②      ③      ④

- ① Model
- ② Output code(ex. 06: 100W)
- ③ Series
- ④ Number of phases and characteristics  
(H: 3 phases; pressure type)

**Selection chart (performance drawings)**

**VKP055H**

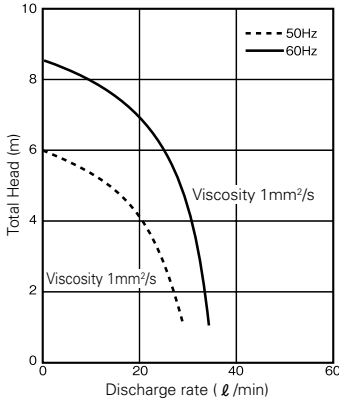

**VKP065H**

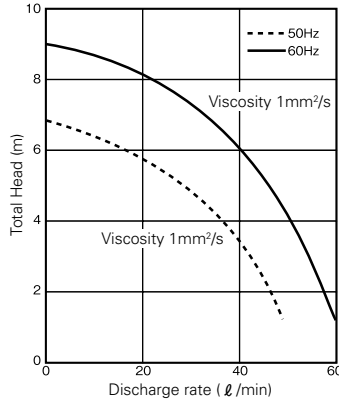

**VKP075H**

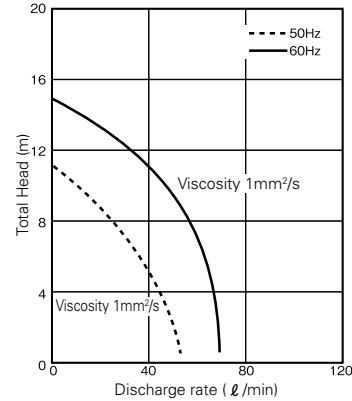

**VKP085H**

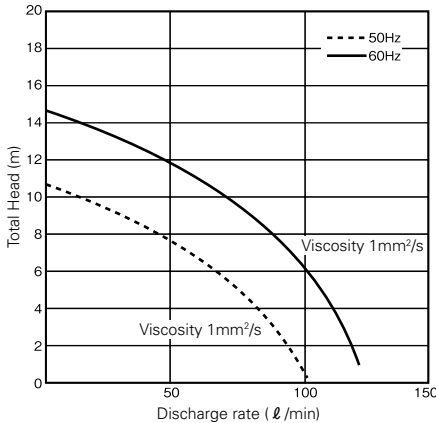

**VKP095H**

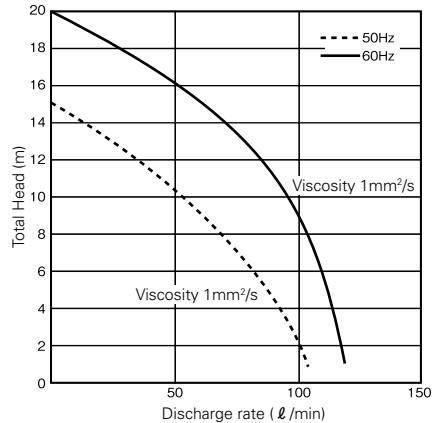

**Specifications**

Specifications	Type	VKP055H		VKP065H		VKP075H		VKP085H		VKP095H	
Nominal output (W)		60		100		180		250		400	
Rated voltage (V)		200	200/220	200	200/220	200	200/220	200	200/220	200	200/220
Frequency (Hz)		50	60	50	60	50	60	50	60	50	60
Rated current (A)		0.42	0.55/0.52	0.55	0.6/0.6	0.9	1.2/1.1	1.2	1.5/1.5	2.4	2.5/2.4
Discharge rate (l/min)		10	10	10	10	20	20	20	20	20	20
Total head (m)		5	7.5	5.5	8	9	13	9	13	13	18
Max. viscosity allowed (mm²/s)		37.5		37.5		37.5		37.5		37.5	
Outlet (Rp)		3/8		3/8		1/2		3/4		1	
Paint color		Munsell N1									
Standard		IEC60034-1 CE approved									
Degree of protection		IP54									

Note: The discharge rate and total head values were obtained in tests with a liquid viscosity of 1mm²/s (same as tap water at normal temperature). Note that the pumps cannot be used with water.

### Assembly Drawing

Fig.1

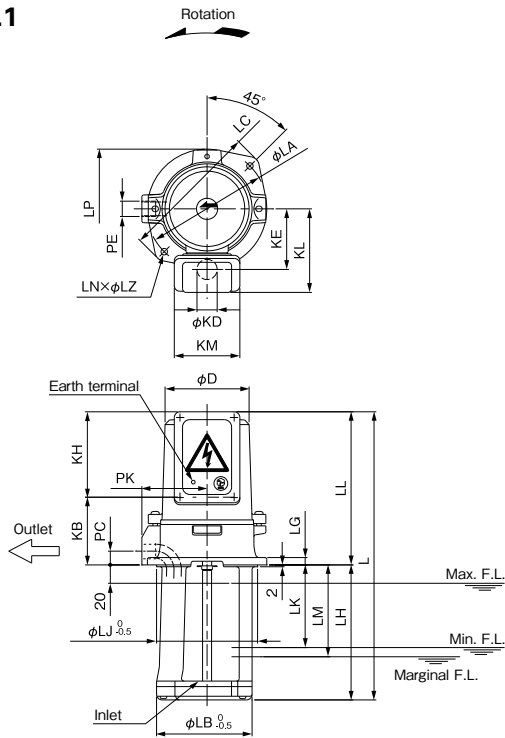
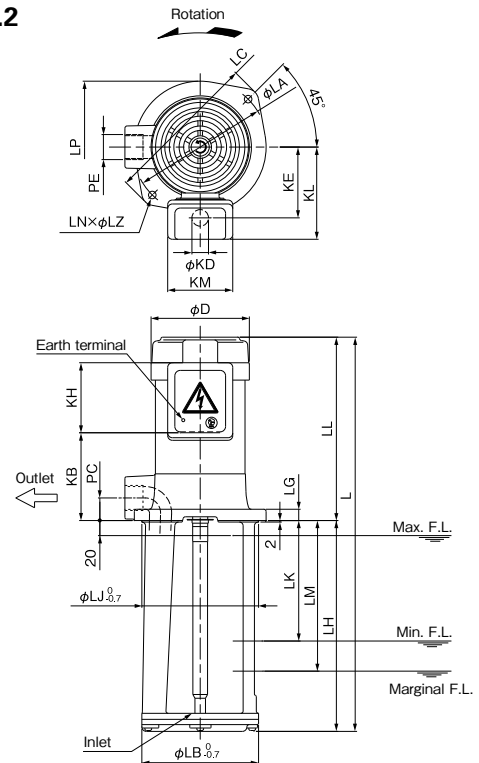

Fig.2



### Dimensions

(Unit : mm)

Type	Fig.	D	KB	KD	KE	KH	KL	KM	L	LA	LB	LC	LG	LH	LJ	LK	LL	LM	LN	LP	LZ	PC	PE	PK	Approx. mass (kg)
VKP055H	1	92	74	22	67	93	93	73	312	132	110	152	8	145	110	90	167	100	2	130	7	15	Rp $\frac{3}{8}$	71	6.0
VKP065H	1	92	74	22	67	93	93	73	317	132	110	152	8	147	110	100	167	110	2	130	7	15	Rp $\frac{3}{8}$	71	6.5
VKP075H	1	111	94	22	78	93	104	73	367	160	135	180	10	180	135	105	187	130	2	154	10	20	Rp $\frac{1}{2}$	80	10.0
VKP085H	1	122	106	22	81	93	107	73	449	160	135	180	10	250	135	165	199	190	2	154	10	25	Rp $\frac{3}{4}$	85	15.0
VKP095H	2	131	117	22	94	93	122	87	524	180	155	206	15	280	155	160	244	200	2	175	10	30	Rp1	—	16.5

### Sectional drawing

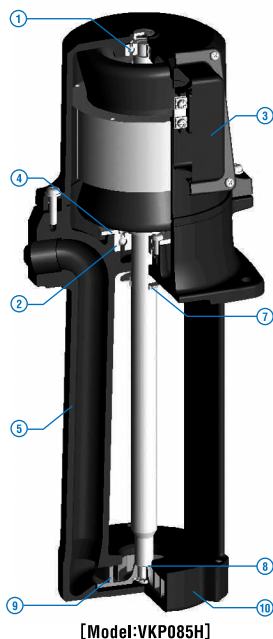

No.	Parts Name	Materials
1	Deep groove ball bearing	
2	Deep groove ball bearing	
3	Terminal box	SPCC
4	End cover	SPHC
5	Pump leg	FC150
7	Oil thrower	SPCC
8	Adjusting washer	BsP3-1 / 2H
9	Impeller	Special resins or CAC407
10	Eddy box	FC150

Note: Structure and other details are subject to change without notice.

**Features**

- ① Small in size, but high in pressure
- ② Meets the EU Directive for CE marking



**Structure**

Non-seal (mechanical seal-less) structure. Cast iron and special resin with high reliability are used in the pump's main unit.

**How to read the model type**

**LHW 20 3 A 0.75**

- ①
- ②
- ③
- ④
- ⑤

- ① Model
- ② Pump's bore diameter
- ③ Number of impellers
- ④ Level of viscosity to be used with (A: For low viscosity)
- ⑤ Output



**Selection chart (performance drawings)**

(The following curves show performance of pump under condition of normal temperature freshwater with specific gravity of 1.)

**50Hz**

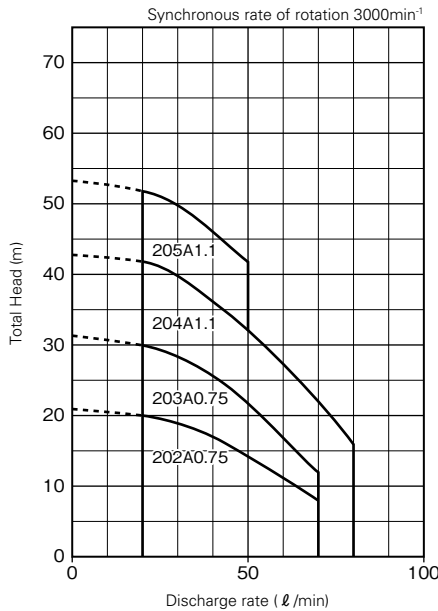

**60Hz**

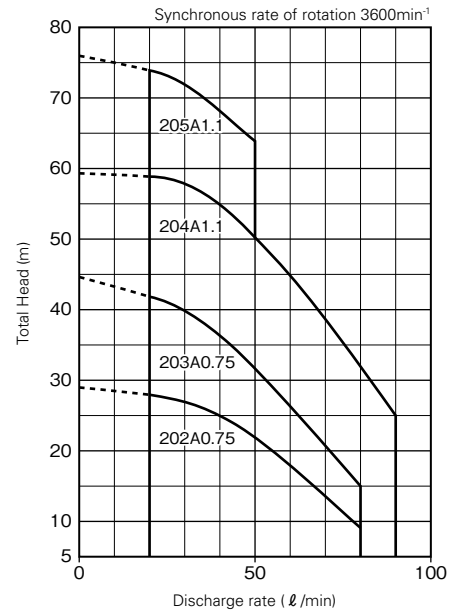

**Specifications**

Type		LHW202A0.75		LHW203A0.75		LHW204A1.1		LHW205A1.1		
Pump	Bore diameter (mm)	20								
	Discharge rate (ℓ/min)	20~70	20~80	20~70	20~80	20~80	20~90	30		
	Total head (m)	20~8	28~9	30~12	42~15	42~16	59~25	50	73	
	Coolants to be used	Water-soluble coolants, cleaning fluids (weak alkali)								
Material		Impeller, intermediate casing, guide vanes ... of special polyamide resin reinforced with glass fiber, etc.								
Motor	Phases	3								
	No. of poles (P)	2								
	Output (kW)	0.75				1.1				
	Voltage (V)	200	200/220	200	200/220	200	200/220	200	200/220	
	Frequency (Hz)	50	60	50	60	50	60	50	60	
	Rated current (A)	3.4	3.4/3.2	3.4	3.4/3.2	4.7	5.3/4.9	4.7	5.3/4.9	
	Synchronous rate of rotation (min <sup>-1</sup> )	3000	3600	3000	3600	3000	3600	3000	3600	
	Insulation class		F							
	Ambient temperature (°C)		40 or below							
	Rating		Continuous							
Method of protection		Totally enclosed fan cooled, indoor								
Bearings	Load side	AC6205ZZ								
	Non-load side	AC6204ZZ								
Approx. mass (kg)		22				24				
Paint color		Munsell N1.5								

※All of the above pumps work at both 50Hz and 60Hz.

### Assembly Drawing

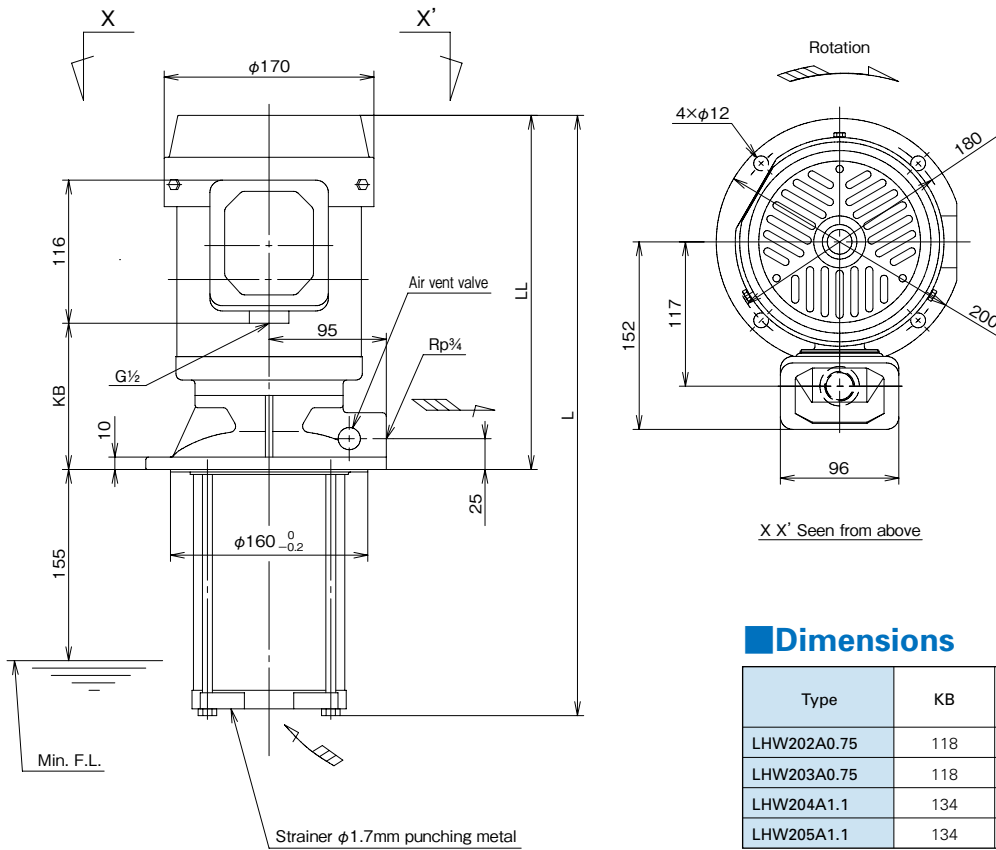

### Dimensions

(Unit: mm)

Type	KB	L	LL
LHW202A0.75	118	487	287
LHW203A0.75	118	487	287
LHW204A1.1	134	502	302
LHW205A1.1	134	502	302

### Sectional drawing

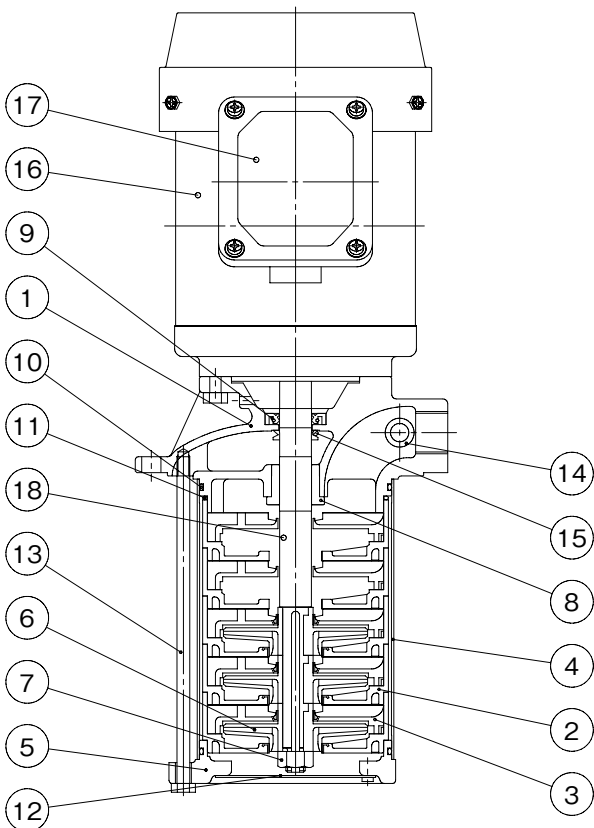

No.	Parts Name	Qty	Materials
1	Discharge casing	1	FC200
2	Intermediate casing	5	ARLS
3	Guide vanes	5	ARLS
4	Outer casing	1	SUS304
5	Suction cover	1	FC200
6	Impeller	n	ARLS
7	Impeller nut	1	SUS304
8	Discharge bush	1	FCD450
9	Oil seal	1	NBR
10	O-ring	2	NBR
11	O-ring	1	NBR
12	Strainer	1	SUS304
13	Tie bolt	4	SS400
14	Air vent valve	1	C3604B
15	V ring	2	NBR
16	Motor	1	
17	Terminal	1	SECC
18	Motor shaft	1	SUS420J2 <sup>※1</sup>

※ 1) The stated motor shaft material is an equivalent material.

Note: The guide vane and intermediate casing in which the impeller is not fitted has no stainless steel ring.

**Features**

- ① Special resins are used in the pump to enhance reliability
- ② New mechanical seal-less structure
- ③ High total head models added to the Series
- ④ EU RoHS Directive (Restriction of Use of Six Hazardous Substances) compliant



**Structure**

Non-seal (mechanical seal-less) structure. Cast iron and special resin with high reliability are used in the pump's main unit.

**How to read the model type**

**VKR 14 5 A** □

- ①
- ②
- ③
- ④
- ⑤

- ① Model
- ② Output code(ex. 14: 2.2kW)
- ③ Series
- ④ Number of phases (A: 3 phases)
- ⑤ Number of impellers (B: 2, C: 3, D: 4, E: 5, F: 6)

**Selection chart (performance drawings)**

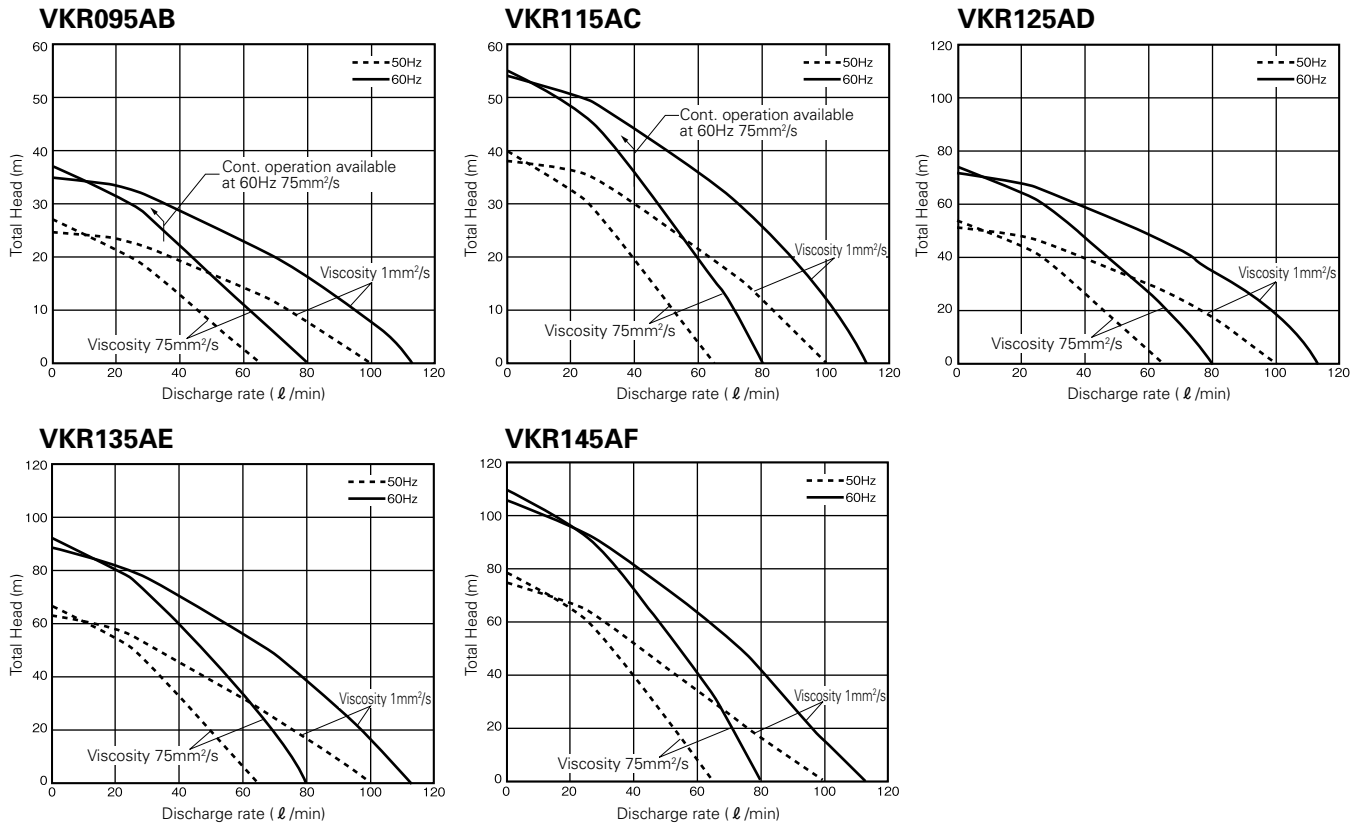

Note: The discharge rate will vary significantly depending on the type of liquid circulated and the liquid's viscosity.

**Specifications**

Specifications	Type	VKR095AB		VKR115AC		VKR125AD		VKR135AE		VKR145AF	
Nominal output	(W)	0.4		0.75		1.1		1.5		2.2	
Rated voltage	(V)	200	200/220	200	200/220	200	200/220	200	200/220	200	200/220
Frequency	(Hz)	50	60	50	60	50	60	50	60	50	60
Rated current	(A)	3	3/3	4.4	4.5/4.5	6	5.9/5.4	7	8.2/8.5	7.6	10.1/9.6
Discharge rate	(l/min)	20	20	30	30	30	30	30	30	30	30
Total head	(m)	22	33	30	43	45	65	52	77	60	90
Max. viscosity allowed	(mm²/s)	75	75*	75	75*	75	75	75	75	75	75
Outlet	(Rp)	3/4		3/4		3/4		3/4		3/4	
Paint color		Munsell N1									
Standard		IEC60034-1 CE approved									
Degree of protection		IP54									

Notes 1. The discharge rate and total head values were obtained in tests with a liquid viscosity of 1mm²/s (same as tap water at normal temperature). Note that the pumps cannot be used with water.  
 2. Mark ★ : For kinematic viscosity 75mm²/s, the VKR095AB can be used at 35 l/min (3A) or less. The VKR115AC can be used at 40 l/min (4.5A) or less.



### Assembly Drawing

Fig.1

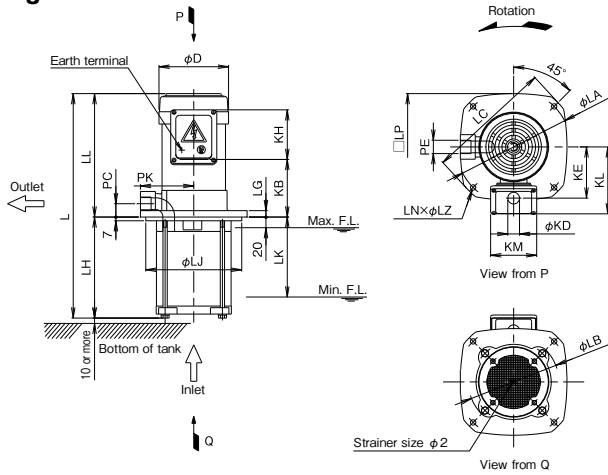

Fig.2

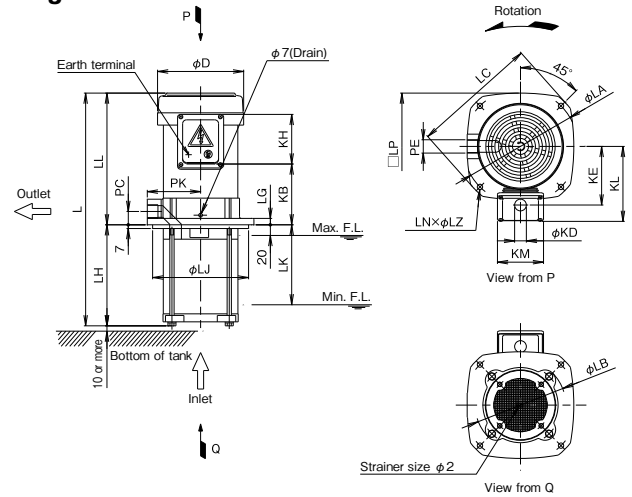
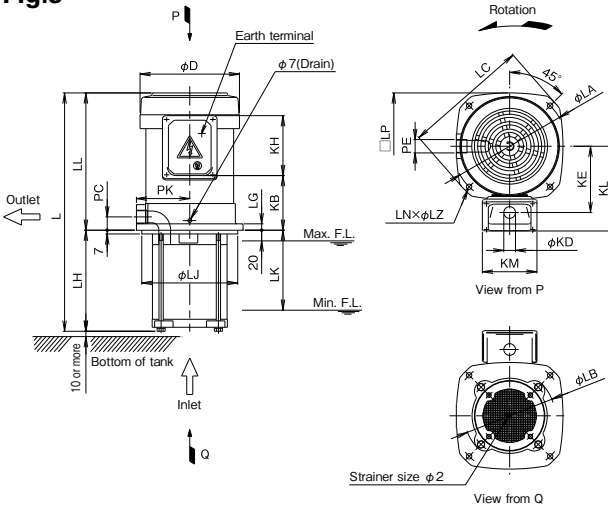

Fig.3



### Dimensions

(Unit: mm)

Type	Fig.	D	KB	KD	KE	KH	KL	KM	L	LA	LB	LC	LG	LH	LJ	LK	LL	LN	LP	LZ	PC	PE	PK	Approx. mass (kg)
VKR095AB	1	131	107	22	96	94	126	87	421	215	170	235	12	190	180 <sup>0</sup> <sub>-0.7</sub>	150	231	4	200	10	25	Rp3/4	100	18.0
VKR115AC	2	162	113	22	110	94	141	87	437	215	170	235	12	190	180 <sup>0</sup> <sub>-0.7</sub>	150	247	4	200	10	25	Rp3/4	100	22.0
VKR125AD	3	187	103	22	124	112	159	102	447	215	170	235	12	190	180 <sup>0</sup> <sub>-0.7</sub>	150	257	4	200	10	25	Rp3/4	100	26.0
VKR135AE	3	187	143	22	124	112	159	102	547	215	170	235	12	250	180 <sup>0</sup> <sub>-0.7</sub>	210	297	4	200	10	25	Rp3/4	100	32.0
VKR145AF	3	187	143	22	124	112	159	102	547	215	170	235	12	250	180 <sup>0</sup> <sub>-0.7</sub>	210	297	4	200	10	25	Rp3/4	100	32.0

## Sectional drawing

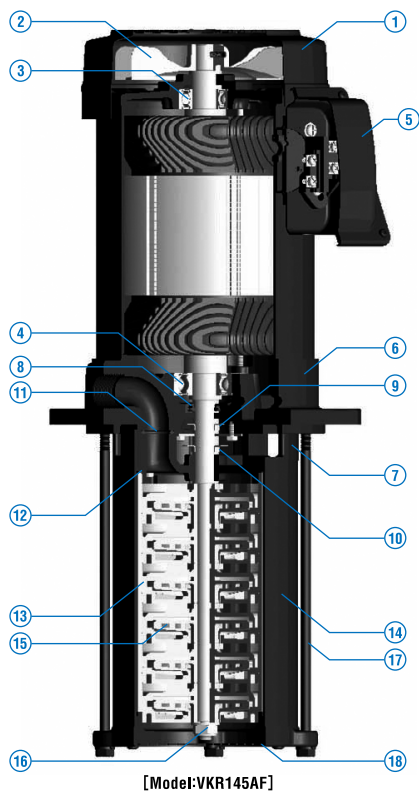

No.	Parts Name	Materials
1	Fan cover	SPCC
2	External fan	Resin
3	Deep groove ball bearing	
4	AC bearing	
5	Terminal box	SPCC
6	Pump leg	FC150
7	Pump leg	FC150
8	Oil seal	NBR
9	Oil thrower	SPC/plated
10	Oil thrower	SPC/plated
11	O-ring	NBR
12	O-ring	NBR
13	Casing	Resin
14	Outer casing	SPHC
15	Impeller	Resin
16	U-nut	SS/plated
17	Fastening bolt	SS/plated
18	Strainer	SUS304

Note: Structure and other details are subject to change without notice.

### Features

- ① Highly durable mechanical seals
  - SiC/porous SiC with special structure for increased wear resistance and adsorption prevention
  - Enhanced resistance to sludge and dry run
- ② EU RoHS Directive (Restriction of Use of Six Hazardous Substances) compliant
- ③ European Standards (EN) compliant
  - EU Directives for CE marking
  - IEC-compatible terminal box
- ④ China energy label regulation (GB18613-2012) efficiency-compliant unit (grade GB3) available
- ⑤ Enhanced protection against mist and other environmental elements
  - IP54 protection
  - Oil seals in the motor
- ⑥ Measures against air suction into the pump when the fluid level lowers
- ⑦ Energy-saving operation by the inverter (flow rate adjusting, etc.)



### Structure

Mechanical seal structure. Aluminum frame is used in the motor section and stainless steel is used in the pump's main unit.

### How to read the model type

**VKA 9 9 6 AH**

①    ②    ③    ④    ⑤    ⑥    ⑦

- ① Model
- ② Number of impellers
- ③ Number of stages
- ④ Series
- ⑤ Number of phases (A: 3 phases)
- ⑥ Characteristics (H: pressure type)
- ⑦ Efficiency regulation-compliant (No mark: standard)
  - G: China energy label regulation (GB18613-2012) efficiency-compliant unit (grade GB3) (200V, 50Hz)
  - GS: China energy label regulation (GB18613-2012) efficiency-compliant unit (grade GB3) (380V, 50Hz)

### Selection chart (performance drawings)

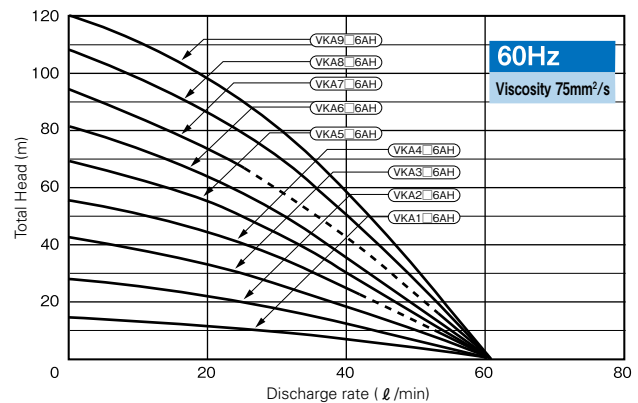
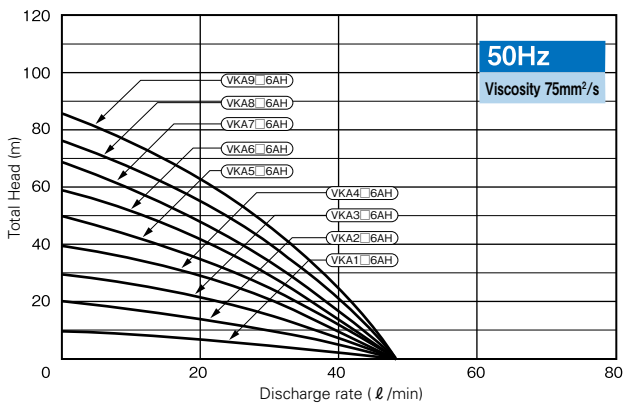
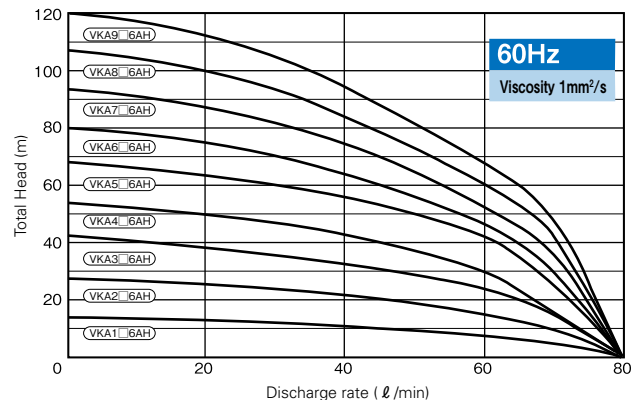
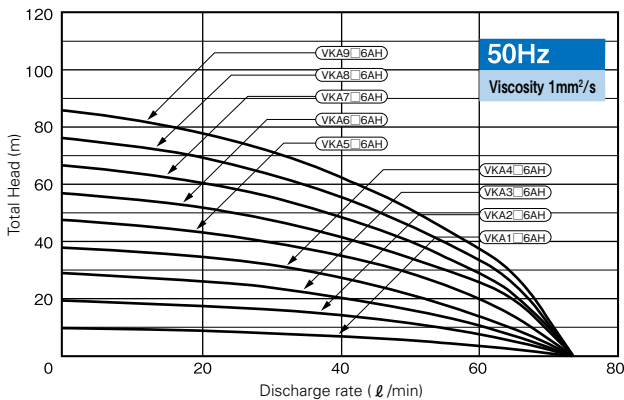

- Notes
1. The discharge rate will vary significantly depending on the type of liquid circulated and the liquid's viscosity.
  2. The dashed line in the above graphs indicates the non-continuously-operable range with oil viscosity of 75mm<sup>2</sup>/s.
  3. The above graphs are performance drawings with viscosity of 75mm<sup>2</sup>/s and specific gravity of 0.86. The unit may not be used depending on the relationship of the liquid viscosity and specific gravity.

Specifications

Specifications	Type	VKA1□6AH	VKA2□6AH	VKA3□6AH	VKA4□6AH	VKA5□6AH	VKA6□6AH	VKA7□6AH	VKA8□6AH	VKA9□6AH										
Nominal output	(W)	0.1	0.17	0.2	0.34	0.3	0.51	0.4	0.68	0.5	0.85	0.6	1.02	0.7	1.19	0.8	1.36	0.9	1.53	
Rated voltage	(V)	200	200	200	200	200	200	200	200	200	200	200	200	200	200	200	200	200	200	200
			220	220	220	220	220	220	220	220	220	220	220	220	220	220	220	220	220	220
Frequency	(Hz)	50	60	50	60	50	60	50	60	50	60	50	60	50	60	50	60	50	60	
Rated current	(A)	2.0	1.9	2.7	2.6	3.3	3.5	3.9	4.5	5.3	5.6	5.8	6.5	6.5	7.1	6.8	8.4	7.5	9.6	
			1.9	2.4	2.4	3.3	3.3	4.3	5.4	6.3	7.1	7.8	8.4	9.6						
Discharge rate	(ℓ/min)	40	50	40	50	40	50	40	50	40	50	40	50	40	50	40	50	40	50	
Total head	(m)	7	9	13	18	20	28	27	37	33	46	40	55	48	62	56	77	63	86	
Max. viscosity allowed	(mm <sup>2</sup> /s)	75	75	75	75	75	75	75	37.5	75	75	75	75	75	37.5	75	75	75	75	
Outlet	(Rp)	3/4		3/4		3/4		3/4		3/4		3/4		3/4		1¼		1¼		
Paint color		Munsell N1																		
Standard		IEC60034-1 CE approved																		
Degree of protection		IP54																		

Notes 1. The discharge rate and total head values were obtained in tests with a liquid viscosity of 1mm<sup>2</sup>/s (same as tap water at normal temperature). Note that the pumps cannot be used with water.  
 2. Note that tap water should not be used. Contact us for further details.

\* For China energy label regulation (GB18613-2012) efficiency-compliant unit (grade GB3), contact us for further details.  
 (VKA1□6AH and VKA2□6AH types are not applicable.)

Special specifications

Motor modifications	Change in voltage, change in position of terminal box, change in direction of terminal box
---------------------	--

Assembly Drawing

Fig.1

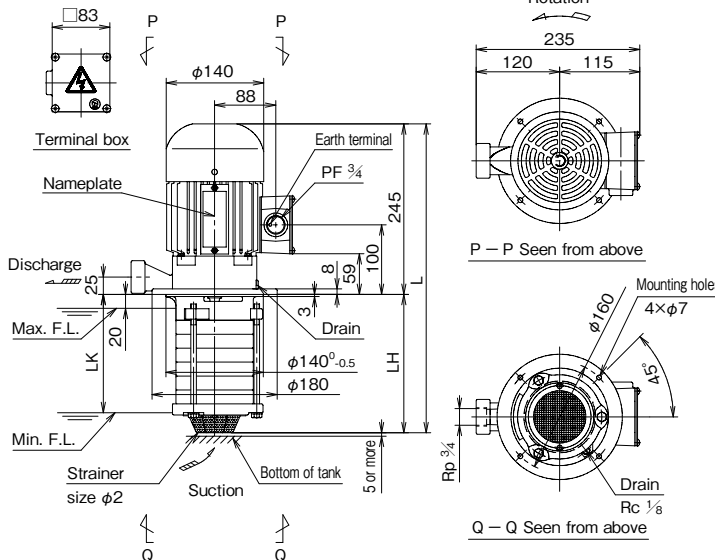
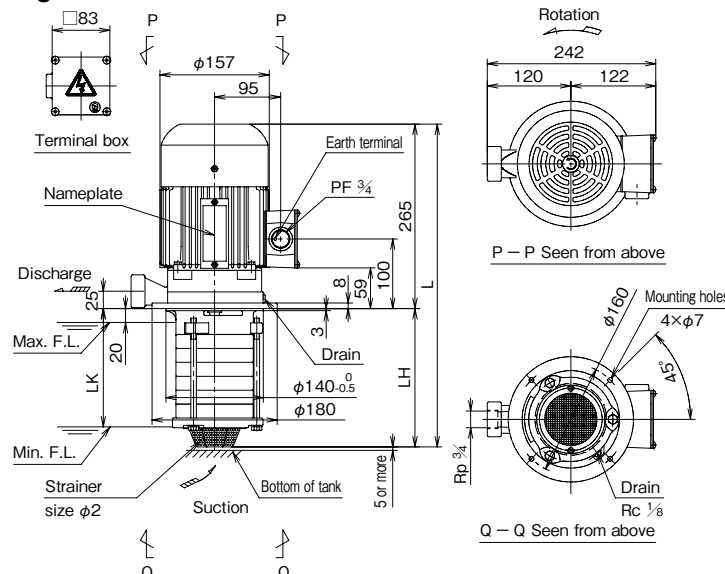

Fig.2



Dimensions

(Unit : mm)

Type	Fig.	L	LH	LK	Approx. mass (kg)
VKA136AH	1	384	139	110	14
VKA146AH		404	159	130	14
VKA156AH		424	179	150	14
VKA166AH		444	199	170	14
VKA236AH		384	139	110	14
VKA246AH		404	159	130	14
VKA256AH		424	179	150	14
VKA266AH		444	199	170	15
VKA276AH		464	219	190	15
VKA286AH		484	239	210	15
VKA296AH		504	259	230	15
VKA336AH		384	139	110	14
VKA346AH		404	159	130	14
VKA356AH		424	179	150	14
VKA366AH		444	199	170	15
VKA376AH		464	219	190	15
VKA386AH		484	239	210	15
VKA396AH		504	259	230	15
VKA446AH		404	159	130	14
VKA456AH		424	179	150	14
VKA466AH	444	199	170	15	
VKA476AH	464	219	190	15	
VKA486AH	484	239	210	15	
VKA496AH	504	259	230	15	
VKA556AH	2	444	179	150	19
VKA566AH		464	199	170	19
VKA576AH		484	219	190	19
VKA586AH		504	239	210	19
VKA596AH		524	259	230	20
VKA666AH		464	199	170	19
VKA676AH		484	219	190	19
VKA686AH		504	239	210	20
VKA696AH		524	259	230	20
VKA776AH		484	219	190	19
VKA786AH	504	239	210	20	
VKA796AH	524	259	230	20	

\* For China energy label regulation (GB18613-2012) efficiency-compliant unit (grade GB3), contact us for further details.

### Assembly Drawing

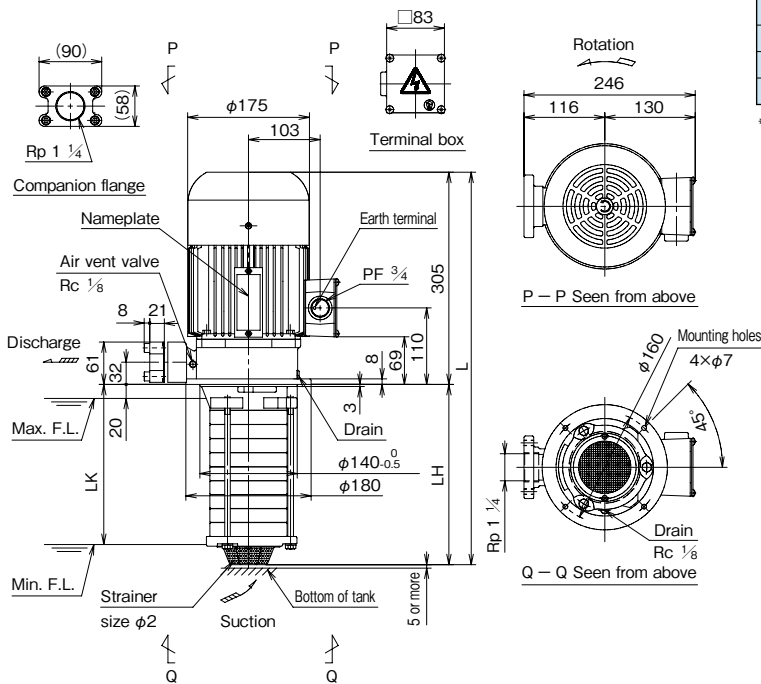

### Dimensions

(Unit: mm)

Type	L	LH	LK	Approx. mass (kg)
VKA886AH	544	239	210	25
VKA896AH	564	259	230	25
VKA996AH	564	259	230	25

\* For China energy label regulation (GB18613-2012) efficiency-compliant unit (grade GB3), contact us for further details.

### Sectional drawing

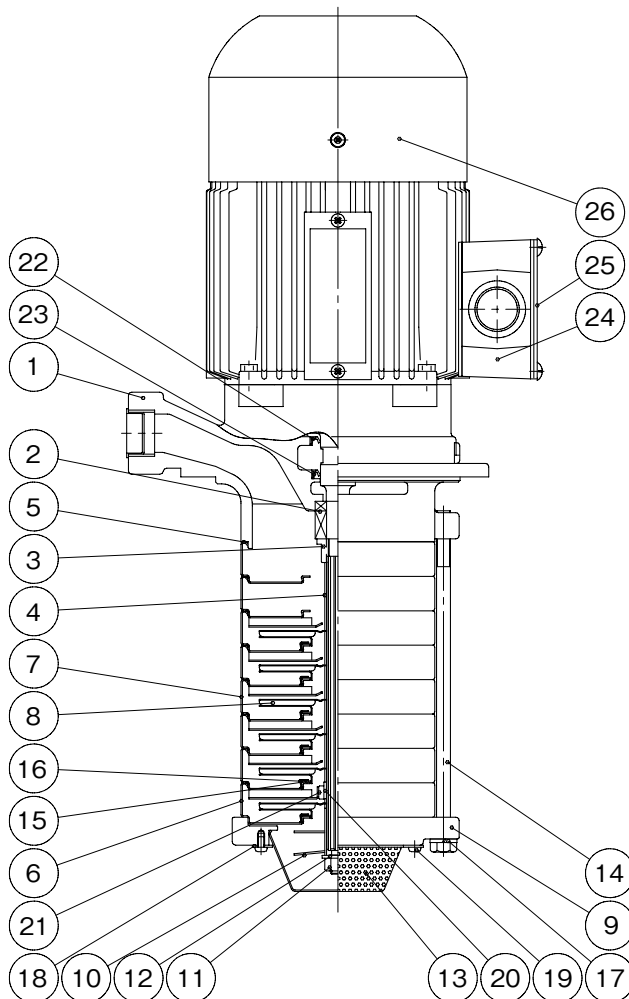

No.	Parts Name	Materials
1	Pump leg	FC150
2	Mechanical seal	SiC/SiC FKM
3	Washer	SUS304
4	Collar	SUS304
5	Teflon packing	PTFE
6	Casing (without guide vanes)	SUS304
7	Casing (with guide vanes)	SUS304
8	Impeller	SUS304
9	Suction chamber	FC200
10	Screw	SUS304
11	U-nut	SUS304
12	Washer	SUS304
13	Wide strainer	SUS304
14	Fastening bolt	SUS304
15	Seal ring	PTFE
16	Clamp	SUS304
17	Spring washer	SUS304
18	Strainer retainer plate	SUS304
19	Cross-recessed pan head machine screw	SUS304
20	Sleeve	WC
21	Bearing ring	CERAMIC
22	Oil seal	NBR
23	Oil seal	NBR
24	Terminal box	ADC
25	Terminal box cover	SS400
26	Motor	

Note: Structure and other details are subject to change without notice.



**Features**

- ① Highly durable mechanical seals
  - SiC/porous SiC with special structure for increased wear resistance and adsorption prevention
  - Enhanced resistance to sludge and dry run
- ② EU RoHS Directive (Restriction of Use of Six Hazardous Substances) compliant
- ③ European Standards (EN) compliant
  - EU Directives for CE marking
  - IEC-compatible terminal box
- ④ China energy label regulation (GB18613-2012) efficiency-compliant unit (grade GB3) available
- ⑤ Enhanced protection against mist and other environmental elements
  - IP54 protection
  - Oil seals in the motor
- ⑥ Measures against air suction into the pump when the fluid level lowers
- ⑦ Energy-saving operation by the inverter (flow rate adjusting, etc.)



**Structure**

Mechanical seal structure. Aluminum frame is used in the motor section and stainless steel is used in the pump's main unit.

**How to read the model type**

**VKA 9 9 6 A Q**

① ② ③ ④ ⑤ ⑥ ⑦

- ① Model
- ② Number of impellers
- ③ Number of stages
- ④ Series
- ⑤ Number of phases (A: 3 phases)
- ⑥ Characteristics (Q: standard type)
- ⑦ Efficiency regulation-compliant (No mark: standard)

-G: China energy label regulation (GB18613-2012) efficiency-compliant unit (grade GB3) (200V, 50Hz)  
 -GS: China energy label regulation (GB18613-2012) efficiency-compliant unit (grade GB3) (380V, 50Hz)

**Selection chart (performance drawings)**

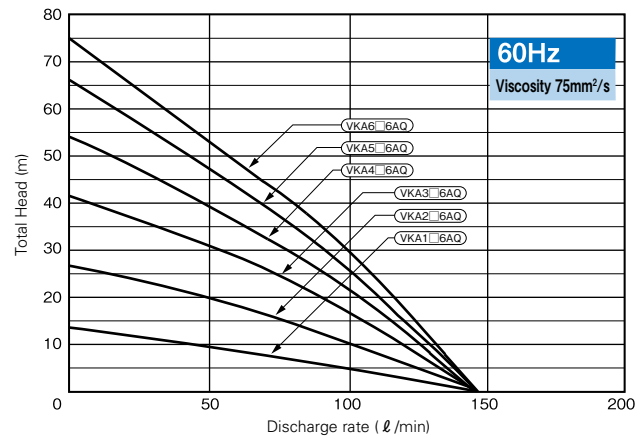
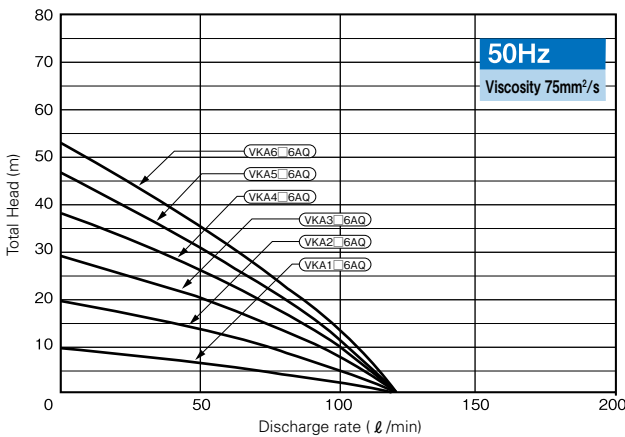
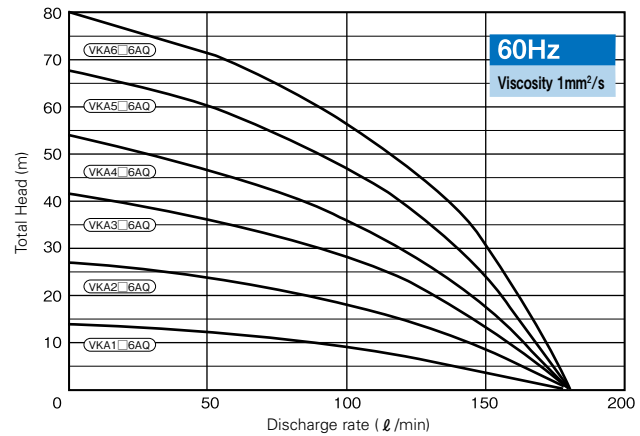
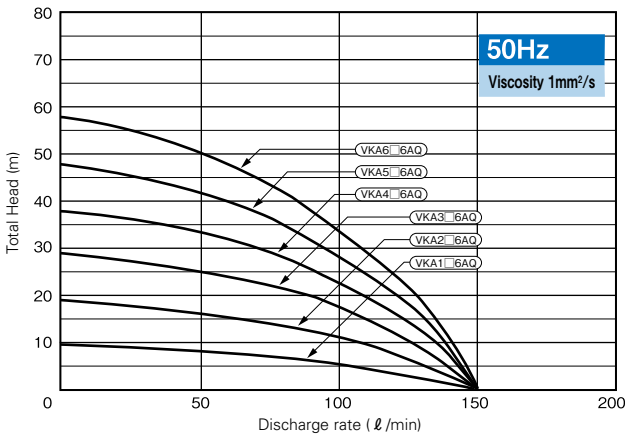

Notes 1. The discharge rate will vary significantly depending on the type of liquid circulated and the liquid's viscosity.  
 2. The dashed line in the above graphs indicates the non-continuously-operable range with oil viscosity of 75mm<sup>2</sup>/s.  
 3. The above graphs are performance drawings with viscosity of 75mm<sup>2</sup>/s and specific gravity of 0.86. The unit may not be used depending on the relationship of the liquid viscosity and specific gravity.

### Specifications

Specifications	Type	VKA1□6AQ		VKA2□6AQ		VKA3□6AQ		VKA4□6AQ		VKA5□6AQ		VKA6□6AQ	
Nominal output (W)		0.18	0.3	0.36	0.6	0.54	0.9	0.72	1.2	0.9	1.5	1.1	1.8
Rated voltage (V)		200	200/220	200	200/220	200	200/220	200	200/220	200	200/220	200	200/220
Frequency (Hz)		50	60	50	60	50	60	50	60	50	60	50	60
Rated current (A)		2.3	2.4/2.3	3.5	4.3/4.1	5.4	6.3/6.1	6.5	7.1/7.1	7.3	10.2/9.2	8.5	11.0/9.8
Discharge rate (ℓ/min)		85	100	85	100	85	100	85	100	85	100	85	100
Total head (m)		6	8	13	18	19	28	26	36	33	46	39	54
Max. viscosity allowed (mm <sup>2</sup> /s)		75	75	75	75	75	75	75	37.5	75	75	75	37.5
Outlet (Rp)		3/4		3/4		3/4		3/4		1¼		1¼	
Paint color		Munsell N1											
Standard		IEC60034-1 CE approved											
Degree of protection		IP54											

Notes 1. The discharge rate and total head values were obtained in tests with a liquid viscosity of 1mm<sup>2</sup>/s (same as tap water at normal temperature). Note that the pumps cannot be used with water.  
2. Note that tap water should not be used. Contact us for further details.

\* For China energy label regulation (GB18613-2012) efficiency-compliant unit (grade GB3), contact us for further details.  
(VKA1□6AQ type is not applicable.)

### Special specifications

Motor modifications	Change in voltage, change in position of terminal box, change in direction of terminal box
---------------------	--

### Assembly Drawing

Fig.1

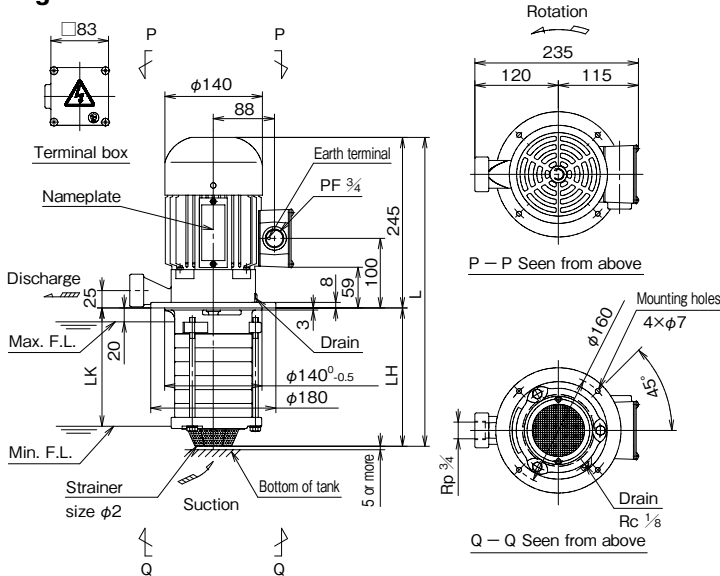
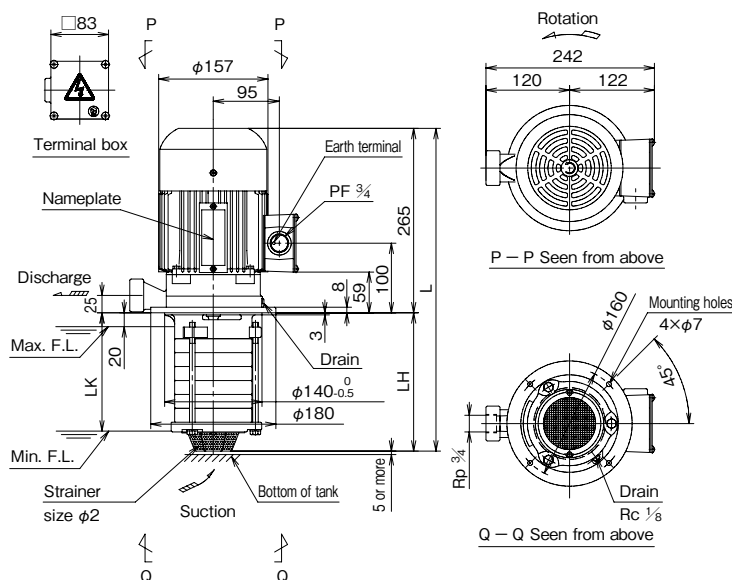

Fig.2



### Dimensions

(Unit : mm)

Type	Fig.	L	LH	LK	Approx. mass (kg)
VKA126AQ	1	382	137	108	14
VKA136AQ		410	165	138	14
VKA146AQ		438	193	164	14
VKA156AQ		466	221	192	14
VKA166AQ		494	249	220	15
VKA226AQ		382	137	108	14
VKA236AQ		410	165	136	14
VKA246AQ		438	193	164	14
VKA256AQ		466	221	192	14
VKA266AQ		494	249	220	15
VKA276AQ		522	277	248	15
VKA286AQ		550	305	276	15
VKA296AQ	578	333	304	15	
VKA336AQ	2	430	165	136	18
VKA346AQ		458	193	164	19
VKA356AQ		486	221	192	19
VKA366AQ		514	249	220	19
VKA446AQ		458	193	164	19
VKA456AQ		486	221	192	19
VKA466AQ		514	249	220	19
VKA476AQ		542	277	248	19
VKA486AQ	570	305	276	20	
VKA496AQ	598	333	304	20	

\* For China energy label regulation (GB18613-2012) efficiency-compliant unit (grade GB3), contact us for further details.

Assembly Drawing

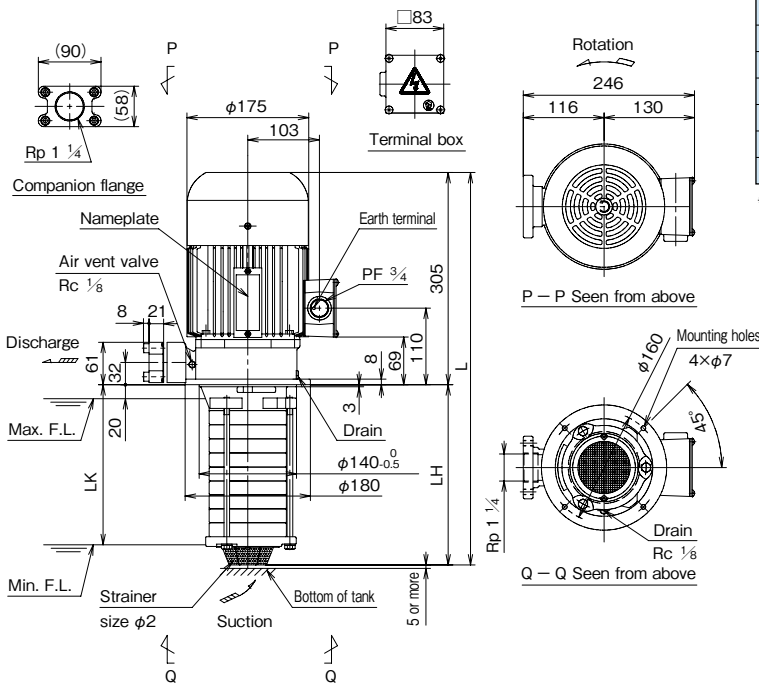

Dimensions

(Unit : mm)

Type	L	LH	LK	Approx. mass (kg)
VKA556AQ	526	221	192	24
VKA566AQ	554	249	220	24
VKA666AQ	554	249	220	25
VKA676AQ	582	277	248	25
VKA686AQ	610	305	276	25
VKA696AQ	638	333	304	25

\* For China energy label regulation (GB18613-2012) efficiency-compliant unit (grade GB3), contact us for further details.

Sectional drawing

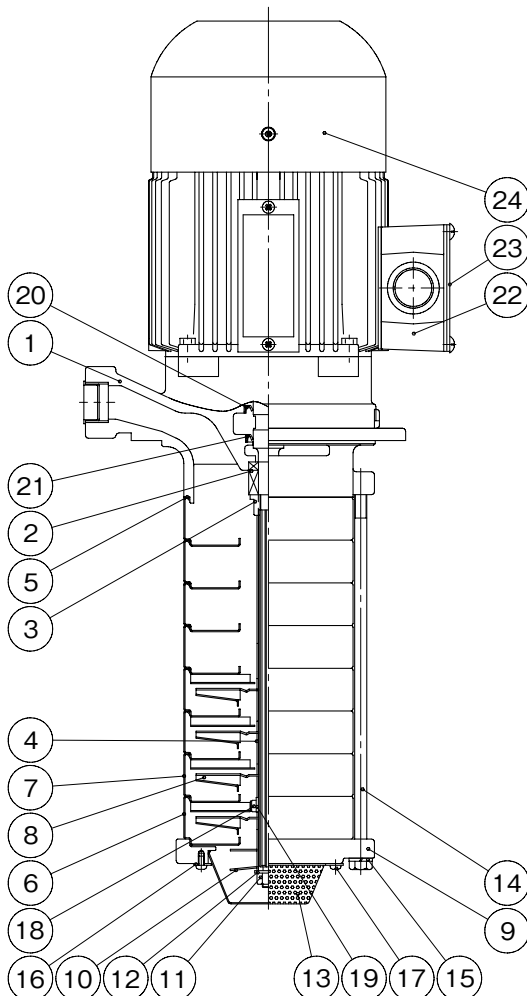

No.	Parts Name	Materials
1	Pump leg	FC150
2	Mechanical seal	SiC/SiC FKM
3	Washer	SUS304
4	Collar	SUS304
5	Teflon packing	PTFE
6	Casing (without guide vanes)	SUS304
7	Casing (with guide vanes)	SUS304
8	Impeller	SUS304
9	Suction chamber	FC200
10	Screw	SUS304
11	U-nut	SUS304
12	Washer	SUS304
13	Wide strainer	SUS304
14	Fastening bolt	SUS304
15	Spring washer	SUS304
16	Strainer retainer plate	SUS304
17	Cross-recessed pan head machine screw	SUS304
18	Bearing ring	CERAMIC
19	Sleeve	WC
20	Oil seal	NBR
21	Oil seal	NBR
22	Terminal box	ADC
23	Terminal box cover	SS400
24	Motor	

Note: Structure and other details are subject to change without notice.

#### Features

- ① All parts exposed to liquid are made of stainless steel
- ② Liquid temperature range -20 to +90°C  
※ Caution: Prevent the liquids from freezing
- ③ Highly durable mechanical seals
  - SiC/porous SiC with special structure for increased wear resistance and adsorption prevention
  - Enhanced resistance to sludge and dry run
- ④ EU RoHS Directive (Restriction of Use of Six Hazardous Substances) compliant
- ⑤ Measures against air suction into the pump when the fluid level lowers
- ⑥ Energy-saving operation by the inverter (flow rate adjusting)



#### Structure

Based on the VKA series for general metal machine tools, stainless steel is used for all parts exposed to liquid.

#### How to read the model type

**VKC 7 9 6 A H**

①    ②    ③    ④    ⑤    ⑥

- ① Model
- ② Number of impellers
- ③ Number of stages
- ④ Series
- ⑤ Number of phases (A: 3 phases)
- ⑥ Characteristics (H: pressure type)

#### Applications

Cold/warm water circulation system / Cleaning system / Water supply system / Mold temperature adjusting machine / Lens polisher / Wet blast machine, etc.

#### Applicable liquids

Freshwater, cleaning solutions, warm water, etc.

#### Selection chart (performance drawings)

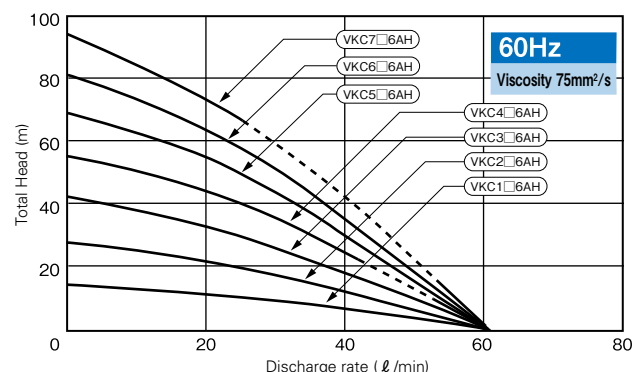
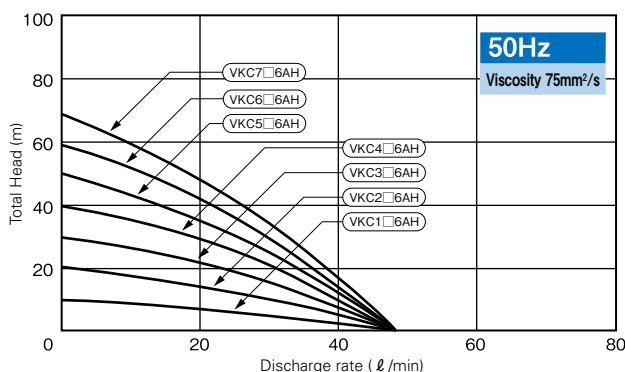
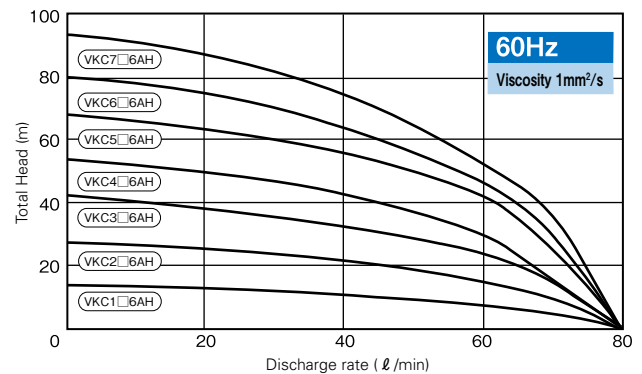
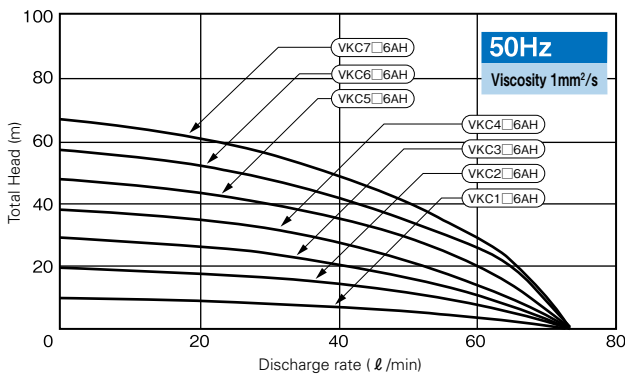

- Notes
1. The discharge rate will vary significantly depending on the type of liquid circulated and the liquid's viscosity.
  2. The dashed line in the above graphs indicates the non-continuously-operable range with oil viscosity of 75mm<sup>2</sup>/s.
  3. The above graphs are performance drawings with viscosity of 75mm<sup>2</sup>/s and specific gravity of 0.86.  
The unit may not be used depending on the relationship of the liquid viscosity and specific gravity.

Specifications

Specifications	Type	VKC1□6AH		VKC2□6AH		VKC3□6AH		VKC4□6AH		VKC5□6AH		VKC6□6AH		VKC7□6AH	
Nominal output (W)		0.1	0.17	0.2	0.34	0.3	0.51	0.4	0.68	0.5	0.85	0.6	1.02	0.7	1.19
Rated voltage (V)		200	200 220	200	220	200	220	200	220	200	220	200	220	200	220
Frequency (Hz)		50	60	50	60	50	60	50	60	50	60	50	60	50	60
Rated current (A)		2.0	1.9 1.9	2.7	2.6 2.4	3.3	3.5 3.3	3.9	4.5 4.3	5.3	5.6 5.4	5.8	6.5 6.3	6.5	7.1 7.1
Discharge rate (ℓ/min)		40	50	40	50	40	50	40	50	40	50	40	50	40	50
Total head (m)		7	9	13	18	20	28	27	37	33	46	40	55	48	62
Max. viscosity allowed (mm <sup>2</sup> /s)		75	75	75	75	75	75	75	37.5	75	75	75	75	75	37.5
Outlet (Rp)		3/4		3/4		3/4		3/4		3/4		3/4		3/4	
Paint color		Munsell N1													
Standard		IEC60034-1 CE approved													
Degree of protection		IP54													

Notes 1. The discharge rate and total head values were obtained in tests with a liquid viscosity of 1mm<sup>2</sup>/s (same as tap water at normal temperature).  
2. Special voltage types are also available. Contact us for further details.

Special specifications

Motor modifications	Change in voltage, change in position of terminal box, change in direction of terminal box
---------------------	--

Assembly Drawing

Fig.1

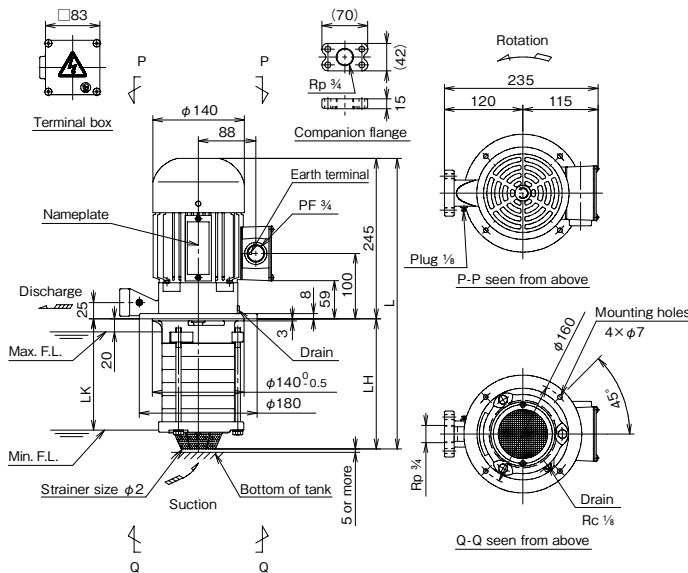
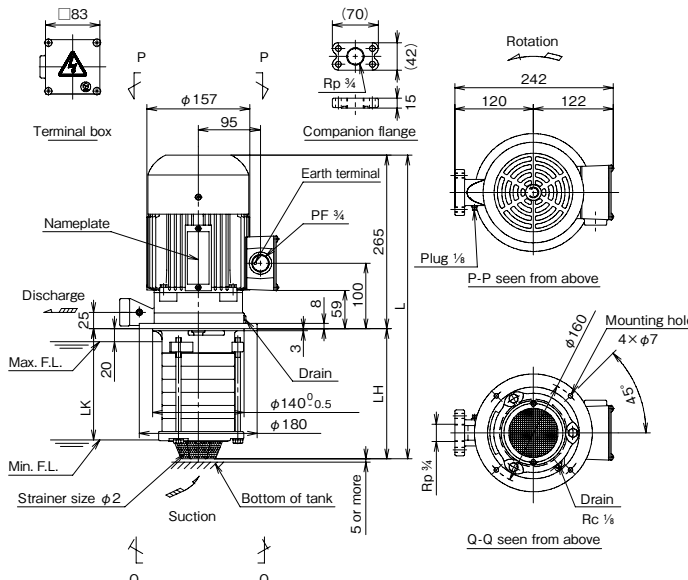

Fig.2



Dimensions

Type	Fig.	L	LH	LK	Approx. mass (kg)
VKC136AH	1	384	139	110	14
VKC146AH		404	159	130	14
VKC156AH		424	179	150	14
VKC166AH		444	199	170	14
VKC236AH		384	139	110	14
VKC246AH		404	159	130	14
VKC256AH		424	179	150	14
VKC266AH		444	199	170	15
VKC276AH		464	219	190	15
VKC286AH		484	239	210	15
VKC296AH		504	259	230	15
VKC336AH		384	139	110	14
VKC346AH		404	159	130	14
VKC356AH		424	179	150	14
VKC366AH		444	199	170	15
VKC376AH		464	219	190	15
VKC386AH		484	239	210	15
VKC396AH		504	259	230	15
VKC446AH		404	159	130	14
VKC456AH		424	179	150	14
VKC466AH	444	199	170	15	
VKC476AH	464	219	190	15	
VKC486AH	484	239	210	15	
VKC496AH	504	259	230	15	
VKC556AH	2	444	179	150	19
VKC566AH		464	199	170	19
VKC576AH		484	219	190	19
VKC586AH		504	239	210	19
VKC596AH		524	259	230	20
VKC666AH		464	199	170	19
VKC676AH		484	219	190	19
VKC686AH		504	239	210	20
VKC696AH		524	259	230	20
VKC776AH		484	219	190	19
VKC786AH	504	239	210	20	
VKC796AH	524	259	230	20	



#### Sectional drawing

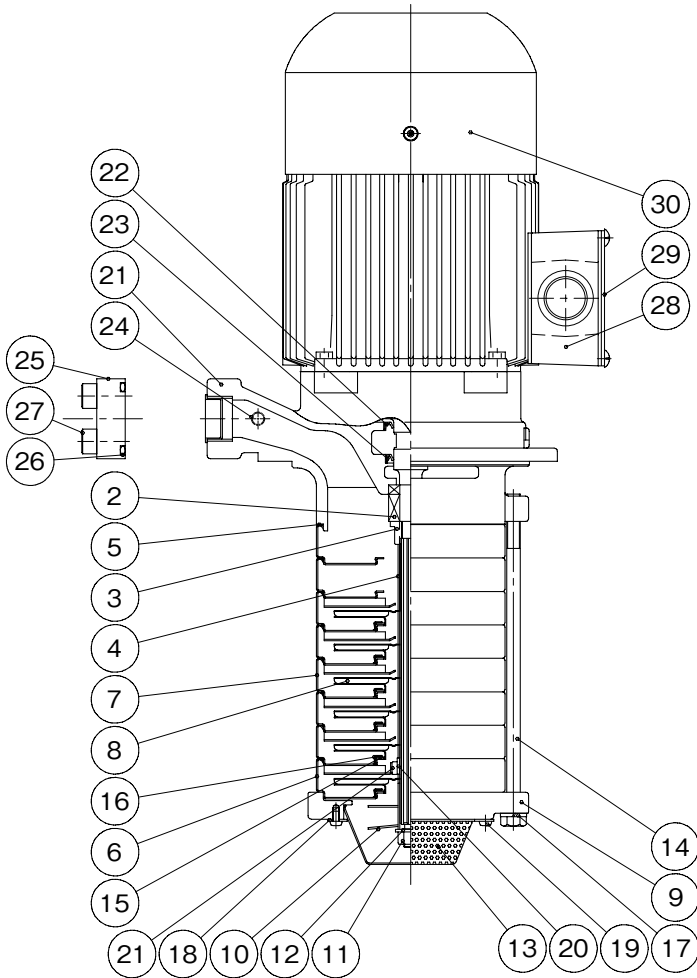

No.	Parts Name	Materials
1	Pump leg	SCS14A
2	Mechanical seal	SiC/SiC FKM
3	Washer	SUS304
4	Collar	SUS304
5	Teflon packing	PTFE
6	Casing (without guide vanes)	SUS304
7	Casing (with guide vanes)	SUS304
8	Impeller	SUS304
9	Suction chamber	SCS14A
10	Screw	SUS304
11	U-nut	SUS304
12	Washer	SUS304
13	Wide strainer	SUS304
14	Fastening bolt	SUS304
15	Seal ring	PTFE
16	Clamp	SUS304
17	Spring washer	SUS304
18	Strainer retainer plate	SUS304
19	Cross-recessed pan head machine screw	SUS304
20	Sleeve	WC
21	Bearing ring	CERAMIC
22	Oil seal	NBR
23	Oil seal	NBR
24	Plug	SUS304
25	Companion flange	SCS16A
26	O-ring	FKM
27	Hexagon socket head bolt	SUS304
28	Terminal box	ADC
29	Terminal box cover	SS400
30	Motor	

Note: Structure and other details are subject to change without notice.

**Features**

- ① All parts exposed to liquid are made of stainless steel
- ② Liquid temperature range -20 to +90°C  
※Caution: Prevent the liquids from freezing
- ③ Highly durable mechanical seals
  - SiC/porous SiC with special structure for increased wear resistance and adsorption prevention
  - Enhanced resistance to sludge and dry run
- ④ EU RoHS Directive (Restriction of Use of Six Hazardous Substances) compliant
- ⑤ Measures against air suction into the pump when the fluid level lowers
- ⑥ Energy-saving operation by the inverter (flow rate adjusting)



**Structure**

Based on the VKA series for general metal machine tools, stainless steel is used for all parts exposed to liquid.

**How to read the model type**

**VKC 4 6 6 A Q**  
① ② ③ ④ ⑤ ⑥

- ① Model
- ② Number of impellers
- ③ Number of stages
- ④ Series
- ⑤ Number of phases (A: 3 phases)
- ⑥ Characteristics (Q: standard type)

**Applications**

Cold/warm water circulation system / Cleaning system / Water supply system / Mold temperature adjusting machine / Lens polisher / Wet blast machine, etc.

**Applicable liquids**

Freshwater, cleaning solutions, warm water, etc.

**Selection chart (performance drawings)**

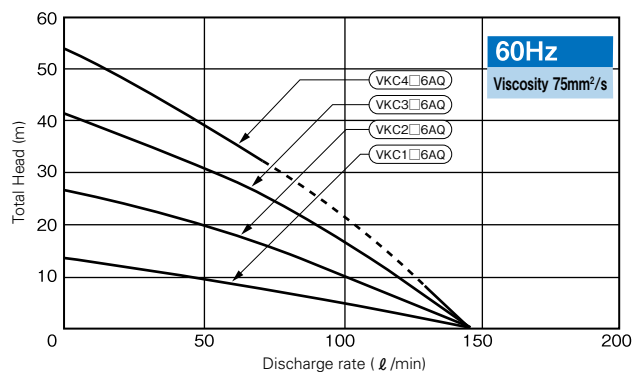
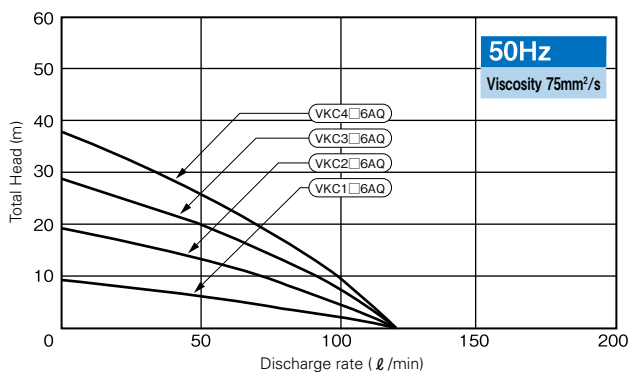
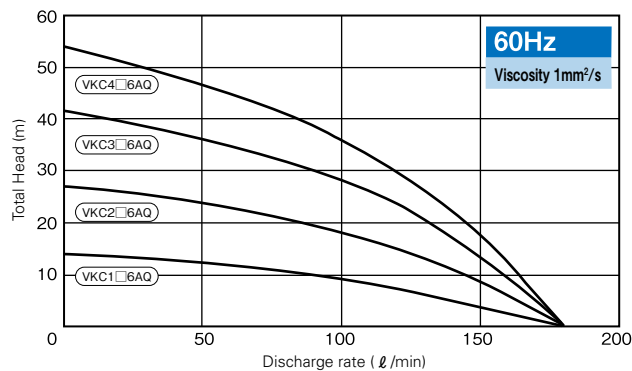
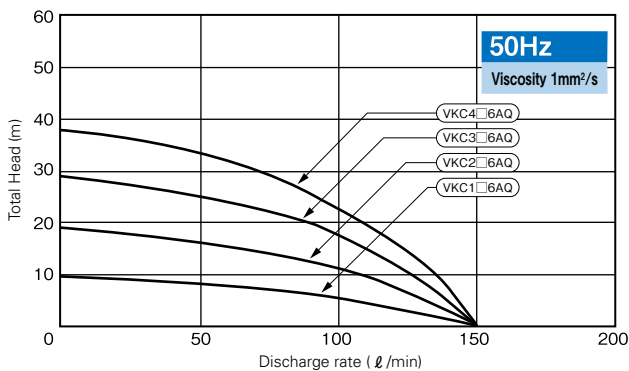

Notes 1. The discharge rate will vary significantly depending on the type of liquid circulated and the liquid's viscosity.  
 2. The dashed line in the above graphs indicates the non-continuously-operable range with oil viscosity of 75mm<sup>2</sup>/s.  
 3. The above graphs are performance drawings with viscosity of 75mm<sup>2</sup>/s and specific gravity of 0.86.  
 The unit may not be used depending on the relationship of the liquid viscosity and specific gravity.

### Specifications

Specifications	Type	VKC1□6AQ		VKC2□6AQ		VKC3□6AQ		VKC4□6AQ	
Nominal output	(W)	0.18	0.3	0.36	0.6	0.54	0.9	0.72	1.2
Rated voltage	(V)	200	200 220	200	200 220	200	200 220	200	200 220
Frequency	(Hz)	50	60	50	60	50	60	50	60
Rated current	(A)	2.3	2.4 2.3	3.5	4.3 4.1	5.4	6.3 6.1	6.5	7.1 7.1
Discharge rate	(ℓ/min)	85	100	85	100	85	100	85	100
Total head	(m)	6	8	13	18	19	28	26	36
Max. viscosity allowed	(mm <sup>2</sup> /s)	75	75	75	75	75	75	75	37.5
Outlet	(Rp)	3/4		3/4		3/4		3/4	
Paint color		Munsell N1							
Standard		IEC60034-1 CE approved							
Degree of protection		IP54							

Notes 1. The discharge rate and total head values were obtained in tests with a liquid viscosity of 1mm<sup>2</sup>/s (same as tap water at normal temperature).  
2. Special voltage types are also available. Contact us for further details.

### Special specifications

Motor modifications	Change in voltage, change in position of terminal box, change in direction of terminal box
---------------------	--

### Assembly Drawing

Fig.1

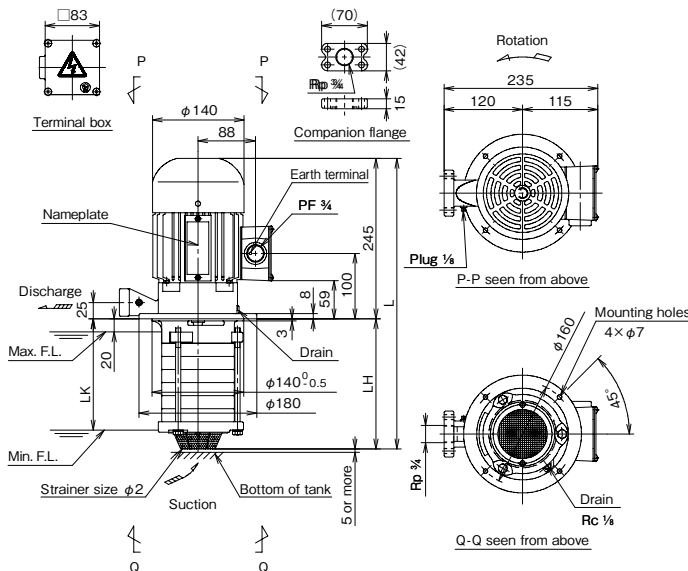

### Dimensions

(Unit: mm)

Type	Fig.	L	LH	LK	Approx. mass (kg)
VKC126AQ	1	382	137	108	14
VKC136AQ		410	165	138	14
VKC146AQ		438	193	164	14
VKC156AQ		466	221	192	14
VKC166AQ		494	249	220	15
VKC226AQ		382	137	108	14
VKC236AQ		410	165	136	14
VKC246AQ		438	193	164	14
VKC256AQ		466	221	192	14
VKC266AQ		494	249	220	15
VKC336AQ	2	430	165	136	18
VKC346AQ		458	193	164	19
VKC356AQ		486	221	192	19
VKC366AQ		514	249	220	19
VKC446AQ		458	193	164	19
VKC456AQ		486	221	192	19
VKC466AQ		514	249	220	19

Fig.2

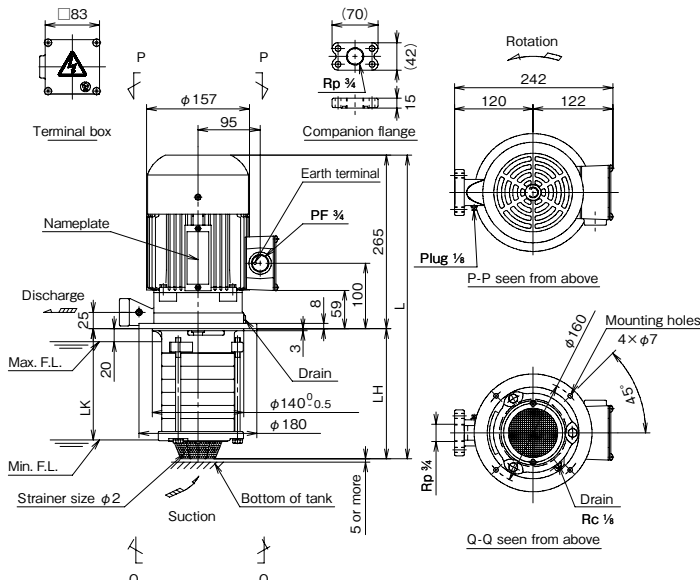

## Sectional drawing

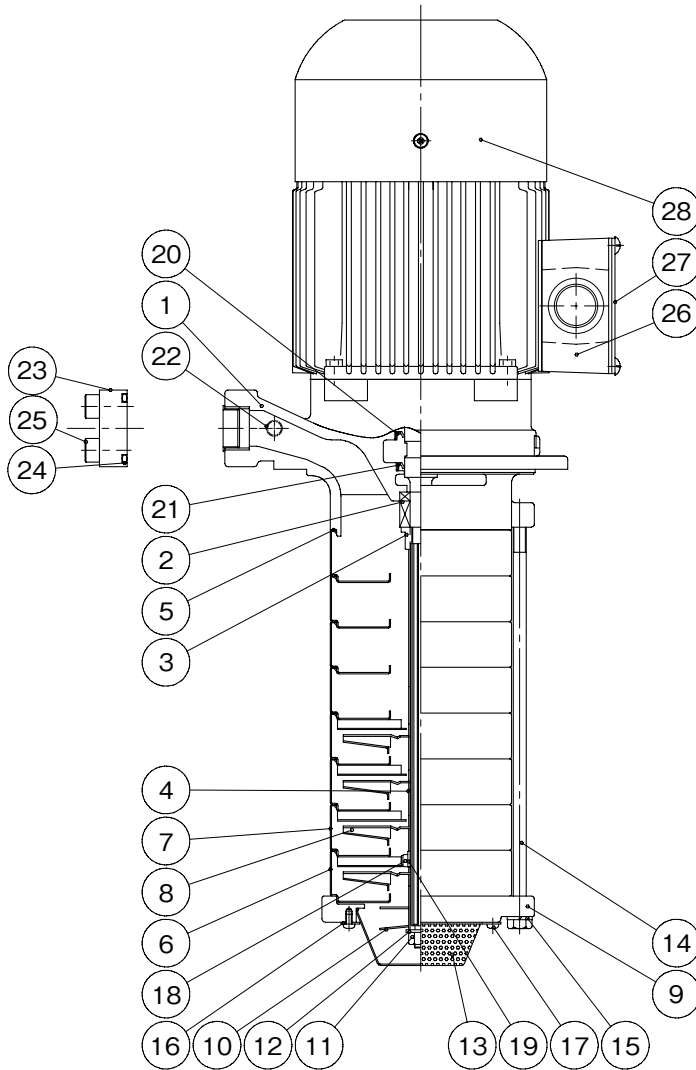

No.	Parts Name	Materials
1	Pump leg	SCS14A
2	Mechanical seal	SiC/SiC FKM
3	Washer	SUS304
4	Collar	SUS304
5	Teflon packing	PTFE
6	Casing (without guide vanes)	SUS304
7	Casing (with guide vanes)	SUS304
8	Impeller	SUS304
9	Suction chamber	SCS14A
10	Screw	SUS304
11	U-nut	SUS304
12	Washer	SUS304
13	Wide strainer	SUS304
14	Fastening bolt	SUS304
15	Seal ring	SUS304
16	Strainer retainer plate	SUS304
17	Cross-recessed pan head machine screw	SUS304
18	Bearing ring	CERAMIC
19	Sleeve	WC
20	Oil seal	NBR
21	Oil seal	NBR
22	Plug	SUS304
23	Companion flange	SCS16A
24	O-ring	FKM
25	Hexagon socket head bolt	SUS304
26	Terminal box	ADC
27	Terminal box cover	SS400
28	Motor	

Note: Structure and other details are subject to change without notice.

### Features

- ① High-efficiency pumps designed for energy-saving coolant piping
- ② Non-seal structure to provide better durability

### Structure

Non-seal (mechanical seal-less) structure. Cast iron is used in the pump's main unit.

### How to read the model type

**LFE 32 A - 0.25 - 300**

- ①      ②      ③      ④      ⑤

- ① Model
- ② Pump's bore diameter
- ③ Level of viscosity to be used with (A: For low viscosity)
- ④ Output
- ⑤ Length below the mounting bed (300mm)



### Selection chart (performance drawings)

(The following curves show performance of pump under condition of normal temperature freshwater with specific gravity of 1.)

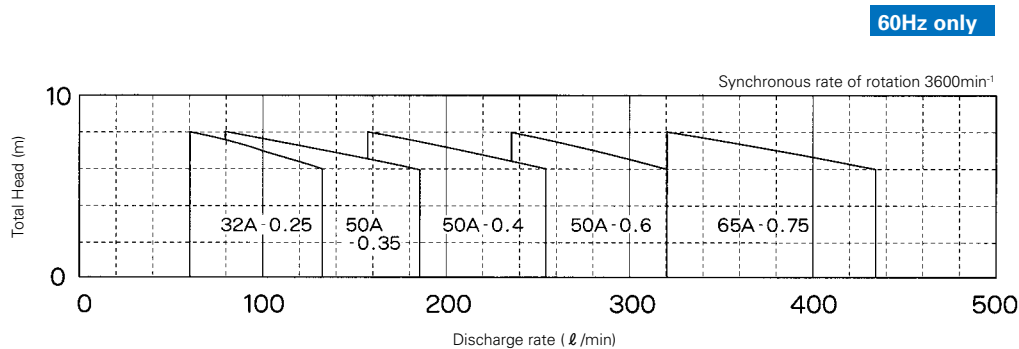

### Specifications

Type		LFE32A-0.25-300	LFE50A-0.35-300	LFE50A-0.4-300	LFE50A-0.6-300	LFE65A-0.75-300
Pump	Bore diameter (mm)	32		50		65
	Discharge rate (ℓ/min)	60~130	80~185	160~255	235~320	320~430
	Total head (m)	8~6				
	Coolants to be used	Water-soluble coolants				
Motor	Phases	3				
	No. of poles (P)	2				
	Output (kW)	0.25	0.35	0.4	0.6	0.75
	Voltage (V)	200/220				
	Rated current (A)	1.16/1.10	1.9/1.82	1.9/1.82	3.8/4.0	3.8/4.0
	Synchronous rate of rotation (min <sup>-1</sup> )	3600				
	Insulation class	F				
	Ambient temperature (°C)	40 or below				
	Rating	Continuous				
	Method of protection	Totally enclosed self-cooling motor			Totally enclosed fan cooled, indoor	
Bearings	Load side	6205ZZC3				
	Non-load side	6303ZZC3				
Paint color		Munsell N1				

Assembly Drawing

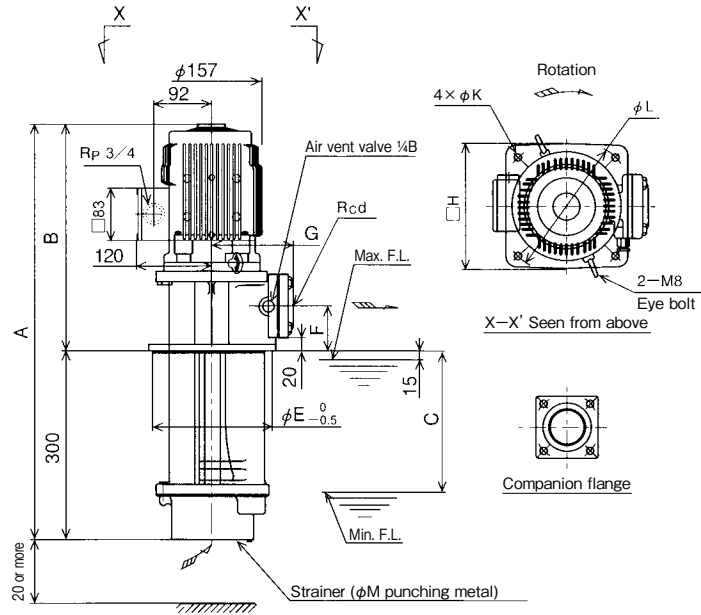

Dimensions

(Unit : mm)

Type	d	A	B	C	E	F	G	H	K	L	M	Approx. mass (kg)
LFE32A-0.25-300	1¼	625.5	325.5	240	160	55	120	180	10	200	7	29
LFE50A-0.35-300	2	659.5	359.5	225	190	70	130	200	12	220	7	34
LFE50A-0.4-300	2	659.5	359.5	225	190	70	130	200	12	220	7	34
LFE50A-0.6-300※	2	697	397	225	190	70	130	200	12	220	7	35
LFE65A-0.75-300※	2½	721.8	421.8	200	220	80	150	230	15	250	8	42

Note: The models with ※ are equipped with a totally enclosed fan cooled motor.

Sectional drawing

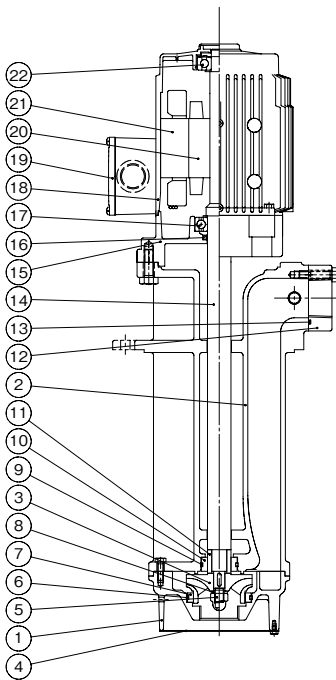

No.	Parts Name	Qty	Materials
1	Suction casing	1	FC200
2	Discharge casing	1	FC200
3	Impeller	1	FCD450
4	Strainer	1	SUS304
5	Impeller nut	1	SUS304
6	O-ring	1	NBR
7	Wearing ring	1	PTFE
8	Washer	1	SUS304
9	O-ring	1	NBR
10	Discharge bush	1	PTFE
11	Shaft sleeve	1	SUS304
12	Companion flange	1	FC200
13	O-ring	1	NBR
14	Motor shaft	1	S35C
15	Motor bracket	1	FC200
16	Oil seal	1	NBR
17	Load-side bearing	1	SUJ2
18	Motor casing	1	ADC
19	Terminal box	1	ADC
20	Rotor	1	S40
21	Stator	1	S40
22	Non-load side bearing	1	SUJ2

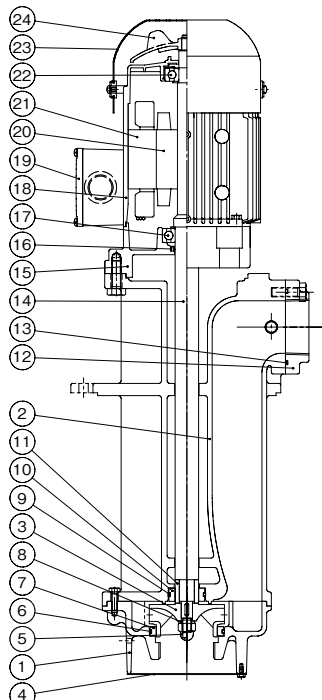

No.	Parts Name	Qty	Materials
1	Suction casing	1	FC200
2	Discharge casing	1	FC200
3	Impeller	1	FCD450
4	Strainer	1	SUS304※1
5	Impeller nut	1	SUS304
6	O-ring	1	NBR
7	Wearing ring	1	PTFE
8	Washer	1	SUS304
9	O-ring	1	NBR
10	Discharge bush	1	PTFE
11	Shaft sleeve	1	SUS304
12	Companion flange	1	FC200
13	O-ring	1	NBR
14	Motor shaft	1	S35C
15	Motor bracket	1	FC200
16	Oil seal	1	NBR
17	Load-side bearing	1	SUJ2
18	Motor casing	1	ADC
19	Terminal box	1	ADC
20	Rotor	1	S40
21	Stator	1	S40
22	Non-load side bearing	1	SUJ2
23	Fan cover	1	SECE
24	Cooling fan	1	Polypropylene

※1: LFE65 is SS400.

Applicable models: LFE32, LFE50 (0.35, 0.4kW)

Applicable models: LFE50(0.6kW), LFE65

### Features

- ① Not easily affected by dirty coolants
- ② The impeller is made of FCD and highly durable
- ③ Two lengths of legs, long and short, are available to be applied below the mounting bed.  
Choose the proper length to fit the depth of the tank
- ④ Can be used for highly viscous coolants (LFO-B models)

### Structure

Non-seal (mechanical seal-less) structure. Cast iron is used in the pump's main unit.

### How to read the model type

## LFO 50 A - 0.75 - 35

①      ②      ③      ④      ⑤

- ① Model
- ② Pump's bore diameter
- ③ Level of viscosity to be used with  
(A: For low viscosity, B: For high viscosity)
- ④ Output
- ⑤ Length below the mounting bed (35: 350mm, 50: 500mm)



### Selection chart (performance drawings)

● For low viscosity coolants (The following curves show performance of pump under condition of normal temperature freshwater with specific gravity of 1.)

50Hz

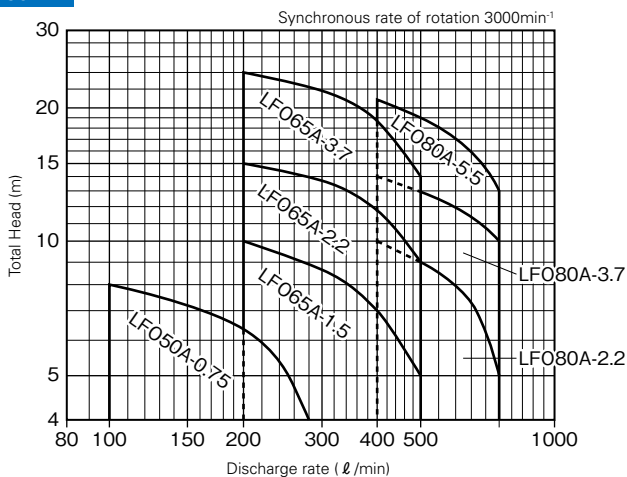

60Hz

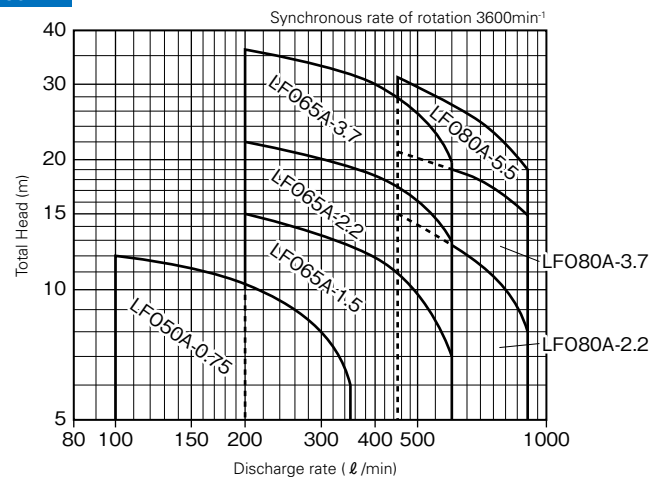

※Use the pumps within the respective ranges specified above. Do not run any of the pumps with a discharge rate smaller than the range specified for it above.

### Specifications

● For low viscosity coolants

50Hz

Type	Length below the mounting bed	350	LFO50A-0.75-35	LFO65A-1.5-35	LFO65A-2.2-35	LFO65A-3.7-35	LFO80A-2.2-35	LFO80A-3.7-35	LFO80A-5.5-35							
		500	LFO50A-0.75-50	LFO65A-1.5-50	LFO65A-2.2-50	LFO65A-3.7-50	LFO80A-2.2-50	LFO80A-3.7-50	LFO80A-5.5-50							
Pump	Bore diameter (mm)	50			65			80								
	Discharge rate (ℓ/min)	100~280			200~500			400~750								
	Total head (m)	8~4			10~5		15~9		24~14		10~5		14~10		21~13	
	Max. viscosity allowed (mm <sup>2</sup> /s)	32														
Motor	Phases	3														
	No. of poles (P)	2														
	Rated output (kW)	0.75			1.5		2.2		3.7		2.2		3.7		5.5	
	Rated voltage (V)	200														
	Rated current (A)	3.7			6.6		8.8		14.2		8.8		14.2		22.4	
	Synchronous rate of rotation (min <sup>-1</sup> )	3000														
	Insulation class	F														
	Rating	Continuous														
	Method of protection	Totally enclosed fan cooled, indoor														
	Bearings	Load side	6205ZZ		6305ZZ		6306ZZ		6208ZZ		6306ZZ		6208ZZ		6210ZZ	
Non-load side		6203ZZ		6303ZZ								6206ZZ		6306ZZ		
Ambient temperature (°C)		40 or below														
Approx. mass (kg)	Length below the mounting bed	350	34		46		56		73		56		74		109	
	500	35		48		58		75		58		76		112		
Paint color		Munsell N1.5														



60Hz

Type	Length below the mounting bed	350	LFO50A-0.75-35	LFO65A-1.5-35	LFO65A-2.2-35	LFO65A-3.7-35	LFO80A-2.2-35	LFO80A-3.7-35	LFO80A-5.5-35		
		500	LFO50A-0.75-50	LFO65A-1.5-50	LFO65A-2.2-50	LFO65A-3.7-50	LFO80A-2.2-50	LFO80A-3.7-50	LFO80A-5.5-50		
Pump	Bore diameter (mm)	50			65			80			
	Discharge rate (ℓ/min)	100~350			200~600			450~900			
	Total head (m)	12~6			15~7			22~13		36~20	
	Max. viscosity allowed (mm <sup>2</sup> /s)	32			32			32			
Motor	Phases	3			3			3			
	No. of poles (P)	2			2			2			
	Rated output (kW)	0.75			1.5			2.2		3.7	
	Rated voltage (V)	200			200			220			
	Rated current (A)	3.5/3.3			6.2/6.0			9.0/8.4		13.8/12.8	
	Synchronous rate of rotation (min <sup>-1</sup> )	3600			3600			3600			
	Insulation class	F			F			F		B	
	Rating	Continuous			Continuous			Continuous			
	Method of protection	Totally enclosed fan cooled, indoor			Totally enclosed fan cooled, indoor			Totally enclosed fan cooled, indoor			
	Bearings	Load side	6205ZZ			6305ZZ			6306ZZ		6208ZZ
Non-load side		6203ZZ			6303ZZ			6206ZZ		6306ZZ	
Ambient temperature (°C)	40 or below			40 or below			40 or below				
Approx. mass (kg)	Length below the mounting bed	350	34	46	56	73	56	74	109		
		500	35	48	58	75	58	76	112		
Paint color	Munsell N1.5										

Selection chart (performance drawings)

●For high viscosity coolants (The following curves show performance of pump under condition of 150cSt viscosity and specific gravity of 1.)

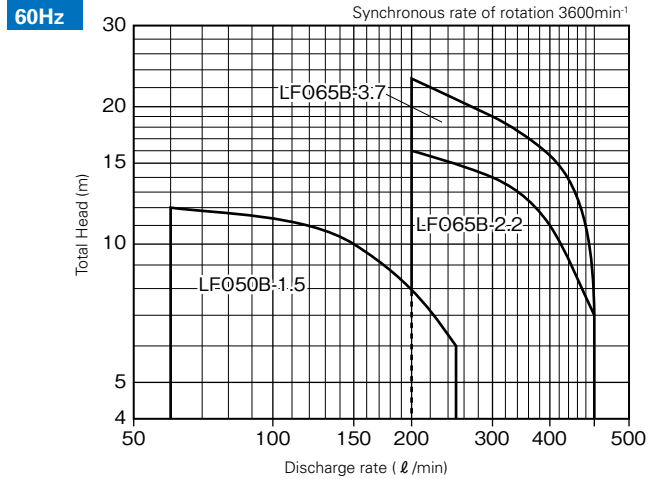
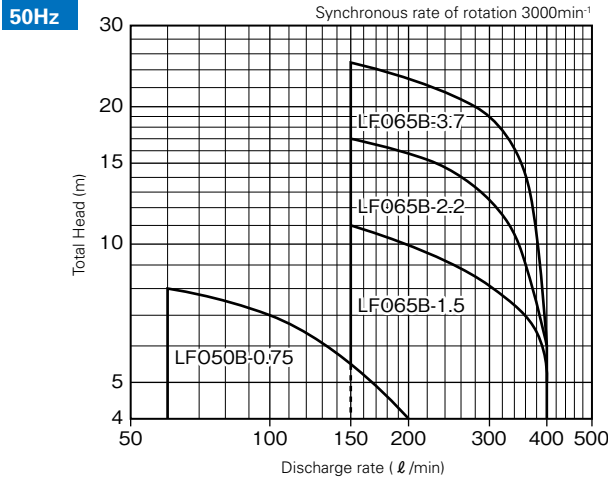

※Use the pumps within the respective ranges specified above. Do not run any of the pumps with a discharge rate smaller than the range specified for it above.

Specifications

●For high viscosity coolants

50Hz

Type	Length below the mounting bed	350	LFO50B-0.75-35	LFO65B-1.5-35	LFO65B-2.2-35	LFO65B-3.7-35	
		500	LFO50B-0.75-50	LFO65B-1.5-50	LFO65B-2.2-50	LFO65B-3.7-50	
Pump	Bore diameter (mm)	50			65		
	Discharge rate (ℓ/min)	60~200			150~400		
	Total head (m)	8~4			11~5		17~6
	Max. viscosity allowed (mm <sup>2</sup> /s)	150			150		
Motor	Phases	3			3		
	No. of poles (P)	2			2		
	Rated output (kW)	0.75			1.5		2.2
	Rated voltage (V)	200			200		
	Rated current (A)	3.7			6.6		8.8
	Synchronous rate of rotation (min <sup>-1</sup> )	3000			3000		
	Insulation class	F			F		B
	Rating	Continuous			Continuous		
	Method of protection	Totally enclosed fan cooled, indoor			Totally enclosed fan cooled, indoor		
	Bearings	Load side	6205ZZ			6305ZZ	
Non-load side		6203ZZ			6303ZZ		6206ZZ
Ambient temperature (°C)	40 or below			40 or below			
Approx. mass (kg)	Length below the mounting bed	350	34	46	56	73	
		500	35	48	58	75	
Paint color	Munsell N1.5						

60Hz

Type	Length below the mounting bed	350	LFO50B-1.5-35	LFO65B-2.2-35	LFO65B-3.7-35	
		500	LFO50B-1.5-50	LFO65B-2.2-50	LFO65B-3.7-50	
Pump	Bore diameter (mm)	50			65	
	Discharge rate (ℓ/min)	60~250			200~500	
	Total head (m)	12~6			16~7	
	Max. viscosity allowed (mm <sup>2</sup> /s)	150			150	
Motor	Phases	3			3	
	No. of poles (P)	2			2	
	Rated output (kW)	1.5			2.2	
	Rated voltage (V)	200			220	
	Rated current (A)	6.2/6.0			9.0/8.4	
	Synchronous rate of rotation (min <sup>-1</sup> )	3600			3600	
	Insulation class	F			B	
	Rating	Continuous			Continuous	
	Method of protection	Totally enclosed fan cooled, indoor			Totally enclosed fan cooled, indoor	
	Bearings	Load side	6305ZZ			6306ZZ
Non-load side		6303ZZ			6206ZZ	
Ambient temperature (°C)	40 or below			40 or below		
Approx. mass (kg)	Length below the mounting bed	350	36	51	73	
		500	38	53	75	
Paint color	Munsell N1.5					

### Assembly Drawing

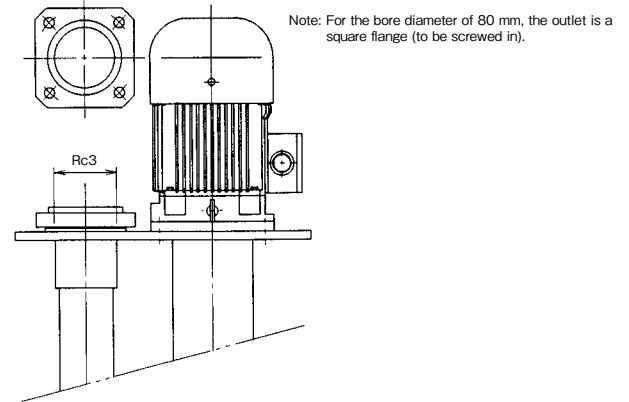
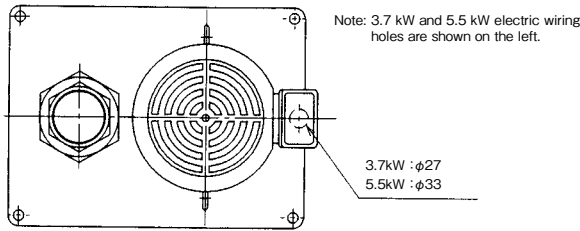
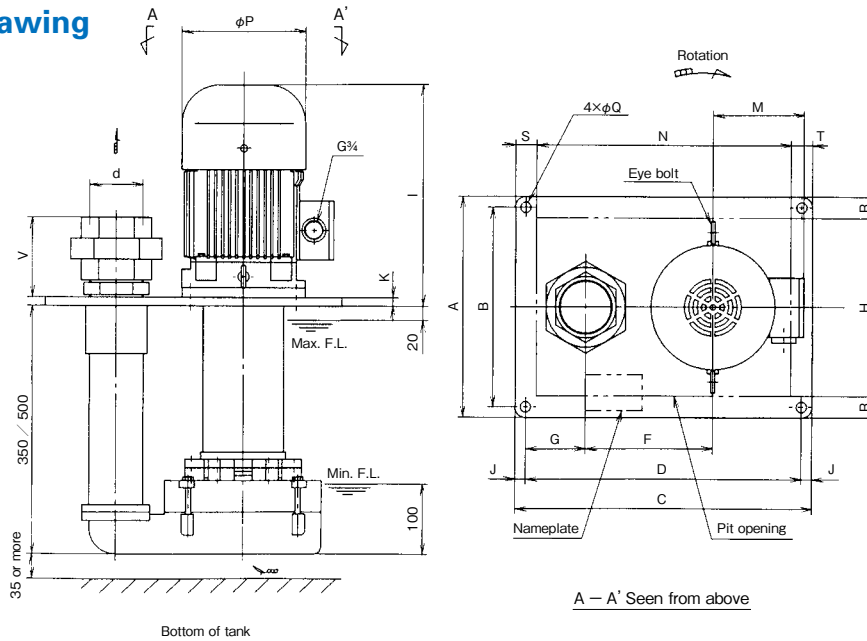

### Dimensions

#### 50Hz

(Unit : mm)

	Type	d	A	B	C	D	F	G	H	I	J	K	M	N	P	Q	R	S	T	V									
For low viscosity coolants	LFO50A-0.75- <sup>35</sup> / <sub>50</sub>	2	260	224	300	264	145	37	170	252	18	12	113	270	140	12	45	10	20	100									
	LFO65A-1.5- <sup>35</sup> / <sub>50</sub>	2½	280	244	370	334	160	67	210	282			120	315	157		35	15	40	115									
	LFO65A-2.2- <sup>35</sup> / <sub>50</sub>		310	280	420	390	180	85	250	312	15		128	360	175	15	30	30	30										
	LFO80A-2.2- <sup>35</sup> / <sub>50</sub>	430			400	190	361			128			370		175														
	LFO80A-3.7- <sup>35</sup> / <sub>50</sub>	330			300	460	430			215				270	415						16	194	400	270					
	LFO80A-5.5- <sup>35</sup> / <sub>50</sub>																												
For high viscosity coolants	LFO50B-0.75- <sup>35</sup> / <sub>50</sub>	2	260	224	300	264	145	37	170	252	18	12	113	270	140	12	45	10	20		100								
	LFO65B-1.5- <sup>35</sup> / <sub>50</sub>	2½	280	244	370	334	160	67	210	282			120	315	157		35	15	40	115									
	LFO65B-2.2- <sup>35</sup> / <sub>50</sub>		310	280	420	390	180	85	250	312	15		128	360	175	15	30	30	30										
	LFO65B-3.7- <sup>35</sup> / <sub>50</sub>	430			400	190	361			128			370		208														
	LFO50B-1.5- <sup>35</sup> / <sub>50</sub>	2			260	224	300			264				145	37						170	282	18	12	120	270	157	12	45
LFO65B-2.2- <sup>35</sup> / <sub>50</sub>	280											244	370												334				160
LFO65B-3.7- <sup>35</sup> / <sub>50</sub>	310	280	420	390	180	85	250	361	158	360	208	15	30	30	30														

#### 60Hz

(Unit : mm)

	Type	d	A	B	C	D	F	G	H	I	J	K	M	N	P	Q	R	S	T	V					
For low viscosity coolants	LFO50A-0.75- <sup>35</sup> / <sub>50</sub>	2	260	224	300	264	145	37	170	252	18	12	113	270	140	12	45	10	20	100					
	LFO65A-1.5- <sup>35</sup> / <sub>50</sub>	2½	280	244	370	334	160	67	210	282			120	315	157		35	15	40	115					
	LFO65A-2.2- <sup>35</sup> / <sub>50</sub>		310	280	420	390	180	85	250	312	15		128	360	175	15	30	30	30						
	LFO80A-2.2- <sup>35</sup> / <sub>50</sub>	430			400	190	361			128			370		208										
	LFO80A-3.7- <sup>35</sup> / <sub>50</sub>	330			300	460	430			215				270	415						16	194	400	270	
	LFO80A-5.5- <sup>35</sup> / <sub>50</sub>																								
For high viscosity coolants	LFO50B-1.5- <sup>35</sup> / <sub>50</sub>	2	260	224	300	264	145	37	170	282	18	12	120	270	157	12	45	10	20		100				
	LFO65B-2.2- <sup>35</sup> / <sub>50</sub>	2½	280	244	370	334	160	67	210	312			128				315			175		15	30	30	30
	LFO65B-3.7- <sup>35</sup> / <sub>50</sub>		310	280	420	390	180	85	250	361	158		360	208	15	30		30	30						
	LFO50B-1.5- <sup>35</sup> / <sub>50</sub>	280			244	370	334			160	67						210			312	128	315	175	12	35
	LFO65B-2.2- <sup>35</sup> / <sub>50</sub>	310			280	420	390			180	85		250	361			15			158	360				

Sectional drawing

●LFO50, LFO65

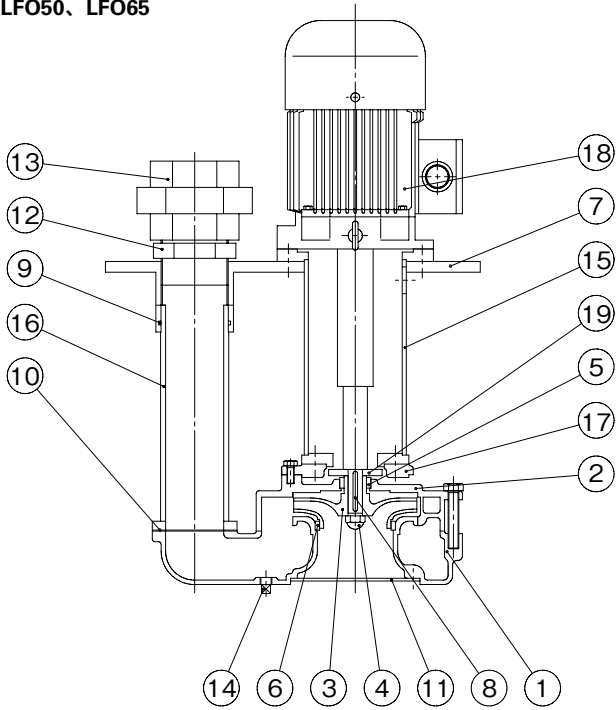

No.	Parts Name	Qty	Materials
1	Casing	1	FC200
2	Casing cover	1	FC200
3	Impeller	1	FCD450
4	Impeller nut	1	SUS304
5	Bushing	1	SUS304
6	Wearing ring	1	SUS304
7	Common base	1	SS400
8	Key	1	S35C
9	O-ring	1	NBR
10	Sheet packing	1	
11	Strainer	1	SS400
12	Nipple	1	FC
13	Union	1	FC
14	Plug	1	SS400
15	Pipe	1	SGP+SS
16	Discharge pipe	1	SGP+SS
17	Flange	1	FC200
18	Motor	1	
19	Deflector	1	SS400

●LFO80

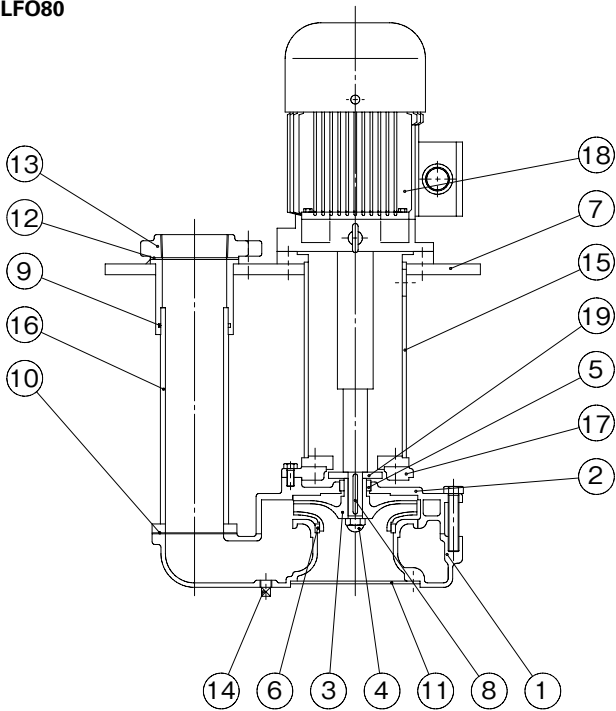

No.	Parts Name	Qty	Materials
1	Casing	1	FC200
2	Casing cover	1	FC200
3	Impeller	1	FCD450
4	Impeller nut	1	SUS304
5	Bushing	1	SUS304
6	Wearing ring	1	SUS304
7	Common base	1	SS400
8	Key	1	S35C
9	O-ring	1	NBR
10	Sheet packing	1	
11	Strainer	1	SS400
12	Sheet packing	1	
13	Companion flange	1	FC200
14	Plug	1	SS400
15	Pipe	1	SGP+SS
16	Discharge pipe	1	SGP+SS
17	Flange	1	FC200
18	Motor	1	
19	Deflector	1	SS400

### Features

- ① Strong and tough enough to resist dirty coolants
- ② New mechanical seal-less structure
- ③ High-pressure, large-capacity pump (500ℓ/min max.)
- ④ EU RoHS Directive (Restriction of Use of Six Hazardous Substances) compliant
- ⑤ Meets the EU Directive for CE marking
- ⑥ China energy label regulation (GB18613-2012) efficiency-compliant unit (grade GB3) available
- ⑦ Long leg type (LH=400 mm); Menu for three models available



### Structure

Non-seal (mechanical seal-less) structure. Motor section and pump section are separated. Cast iron is used in the pump's main unit.

### How to read the model type

**VKD 15 1 A** □

①    ②    ③    ④    ⑤    ⑥

- ① Model
- ② Output code(ex. 15: 3.0kW)
- ③ Series
- ④ Number of phases (A: 3 phases)
- ⑤ Number of impellers / Leg length (A: 1, B: 2 (standard), C: 3 (standard), D: 4 (standard), F: 2 (400 mm), G: 3 (400 mm), H: 4 (400 mm))
- ⑥ Compliance with energy efficiency regulation (no description: standard)
  - G: China energy label regulation (GB18613-2012) efficiency-compliant unit (grade GB3) (200V, 50Hz)
  - GS: China energy label regulation (GB18613-2012) efficiency-compliant unit (grade GB3) (220/380V, 50Hz)

### Selection chart (performance drawings)

**VKD111AA/111AA-G/111AA-GS**

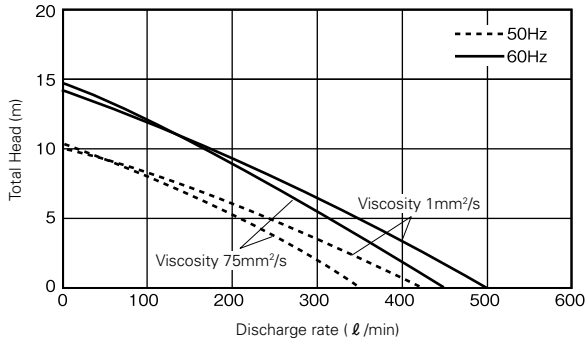

**VKD131AB/131AB-G/131AB-GS**

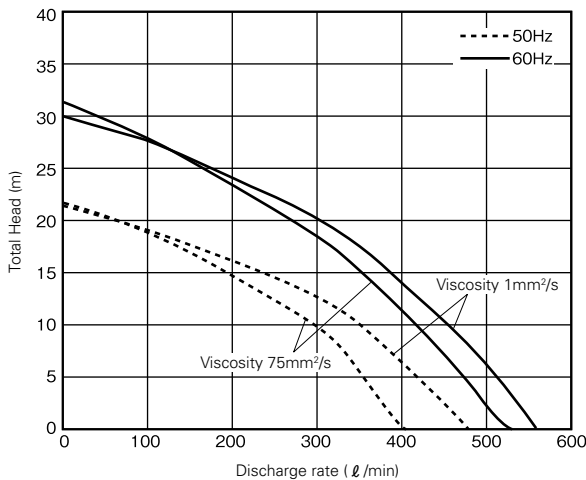

**VKD131AF/131AF-G/131AF-GS**

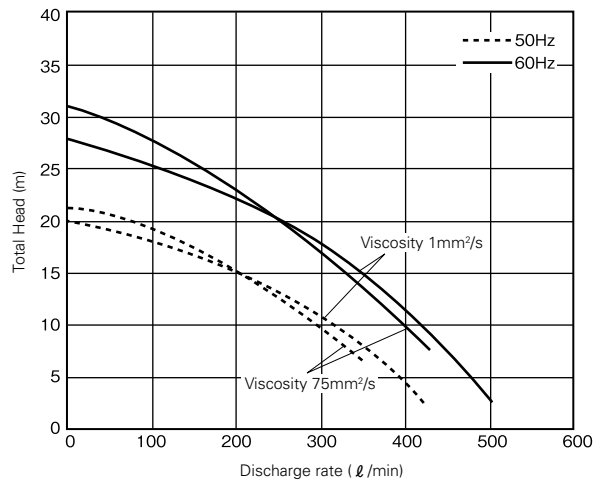

Note: The discharge rate will vary significantly depending on the type of liquid circulated and the liquid's viscosity.

Selection chart (performance drawings)

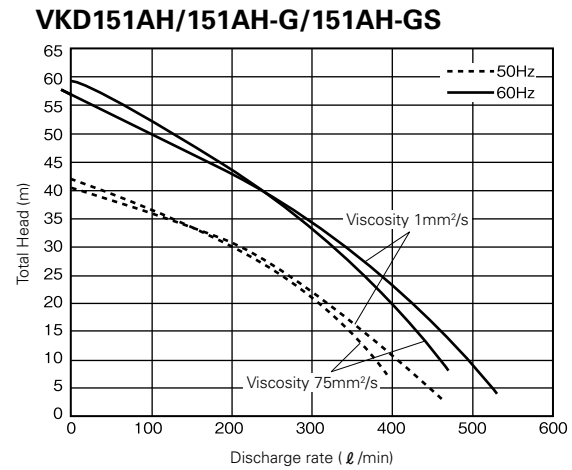
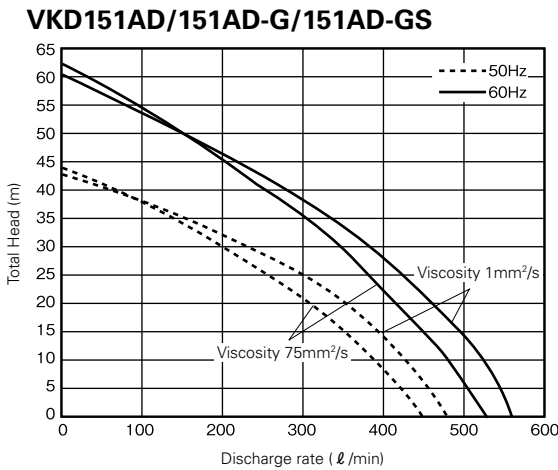
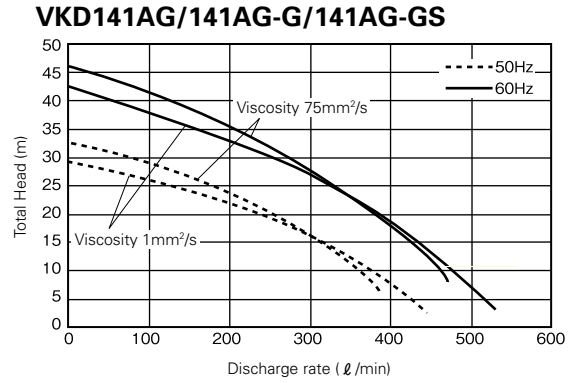
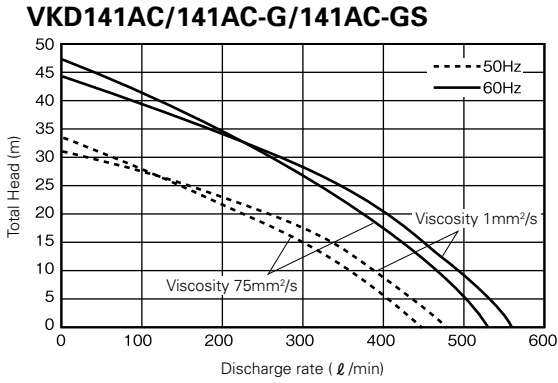

Note: The discharge rate will vary significantly depending on the type of liquid circulated and the liquid's viscosity.

Specifications

Standard leg

Specifications	Type	VKD111AA		VKD131AB		VKD141AC		VKD151AD	
Nominal output	(W)	0.75		1.5		2.2		3.0	
Rated voltage	(V)	200	200/220	200	200/220	200	200/220	200	200/220
Frequency	(Hz)	50	60	50	60	50	60	50	60
Rated current	(A)	4.7	5/4.9	7.6	10/9.2	13.7	13.6/13.2	16	17.3/16
Discharge rate	(l/min)	80~300	100~400	80~400	100~500	80~400	100~500	80~400	100~500
Total head	(m)	8~4	12~4	20~7	28~7	29~9	40~9	40~14	54~14
Max. viscosity allowed	(mm²/s)	75	75	75	75	75	75	75	75
Outlet	(Rp)	1½							
Paint color		Munsell N1							
Standard		IEC60034-1 CE approved							
Degree of protection		IP54							

Long leg

Specifications	Type	VKD131AF		VKD141AG		VKD151AH	
Nominal output	(W)	1.5		2.2		3.0	
Rated voltage	(V)	200	200/220	200	200/220	200	200/220
Frequency	(Hz)	50	60	50	60	50	60
Rated current	(A)	7.6	10/9.2	13.7	13.6/13.2	16	17.3/16
Discharge rate	(l/min)	80~400	100~500	80~400	100~500	80~400	100~500
Total head	(m)	18~4	25~2	27~7	38~7	37~11	50~8
Max. viscosity allowed	(mm²/s)	75	75	75	75	75	75
Outlet	(Rp)	2					
Paint color		Munsell N1					
Standard		IEC60034-1 CE approved					
Degree of protection		IP54					

Note: The discharge rate and total head values were obtained in tests with a liquid viscosity of 1 mm²/s (same as tap water at normal temperature). Note that the pumps cannot be used with water.

### China energy label regulation (GB18613-2012) efficiency-compliant unit (grade GB3)

Specifications	Type	VKD111AA-G	VKD111AA-GS	VKD131AB-G	VKD131AB-GS	VKD131AF-G	VKD131AF-GS	VKD141AC-G
Nominal output (W)		0.75	0.75	1.5	1.5	1.5	1.5	2.2
Rated voltage (V)		200	220/380	200	220/380	200	220/380	200
Frequency (Hz)		50						
Rated current (A)		4	3.6/2.1	6.9	6.9/4.0	6.9	6.9/4.0	10.6
Discharge rate (ℓ/min)		80~300	80~300	80~400	80~400	80~400	80~400	80~400
Total head (m)		8~4	8~4	20~7	20~7	18~4	18~4	29~9
Max. viscosity allowed (mm <sup>2</sup> /s)		75						
Outlet (Rp)		1½	1½	1½	1½	2	2	1½
Paint color		Munsell N1						
Standard		IEC60034-1 CE approved						
Degree of protection		IP44						

Specifications	Type	VKD141AC-GS	VKD141AG-G	VKD141AG-GS	VKD151AD-G	VKD151AD-GS	VKD151AH-G	VKD151AH-GS
Nominal output (W)		2.2	2.2	2.2	3.0	3.0	3.0	3.0
Rated voltage (V)		220/380	200	220/380	200	220/380	200	220/380
Frequency (Hz)		50						
Rated current (A)		10.6/6.2	10.6	10.6/6.2	16.0	12/6.9	13.3	12/6.9
Discharge rate (ℓ/min)		80~400	80~400	80~400	80~400	80~400	80~400	80~400
Total head (m)		29~9	27~7	27~7	40~14	40~14	37~11	37~11
Max. viscosity allowed (mm <sup>2</sup> /s)		75						
Outlet (Rp)		1½	2	2	1½	1½	2	2
Paint color		Munsell N1						
Standard		IEC60034-1 CE approved						
Degree of protection		IP44						

Note: The discharge rate and total head values were obtained in tests with a liquid viscosity of 1mm<sup>2</sup>/s (same as tap water at normal temperature). Note that the pumps cannot be used with water.

### Assembly Drawing

Fig.1

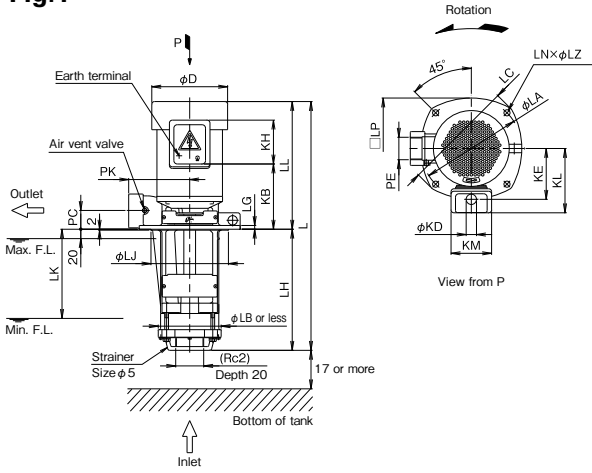

Fig.2

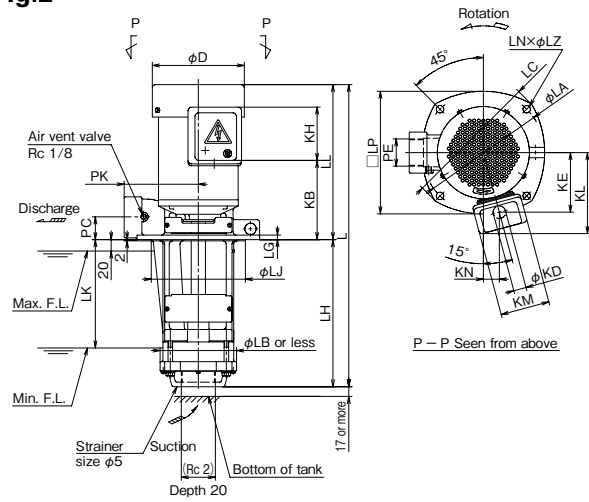

Fig.3

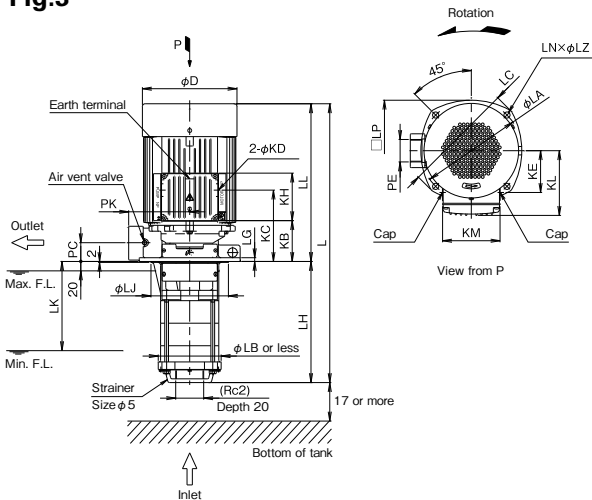

Fig.4

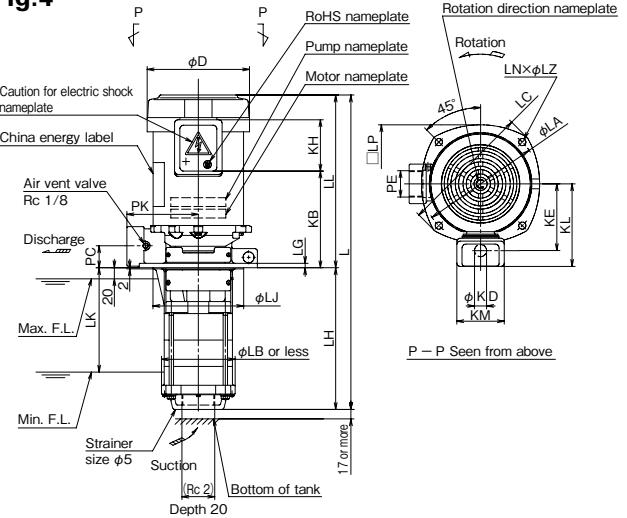

Fig.5

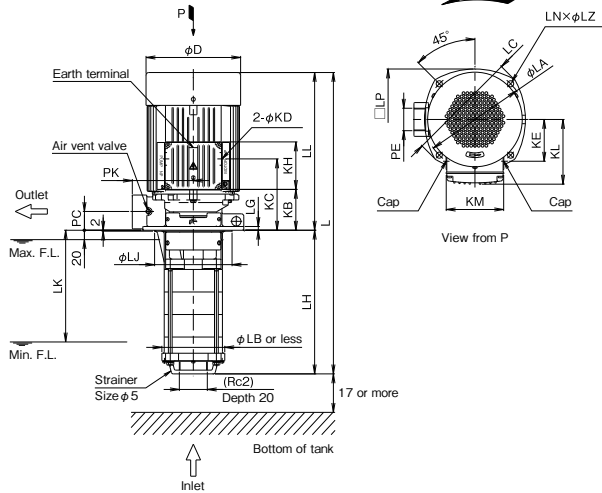

Fig.6

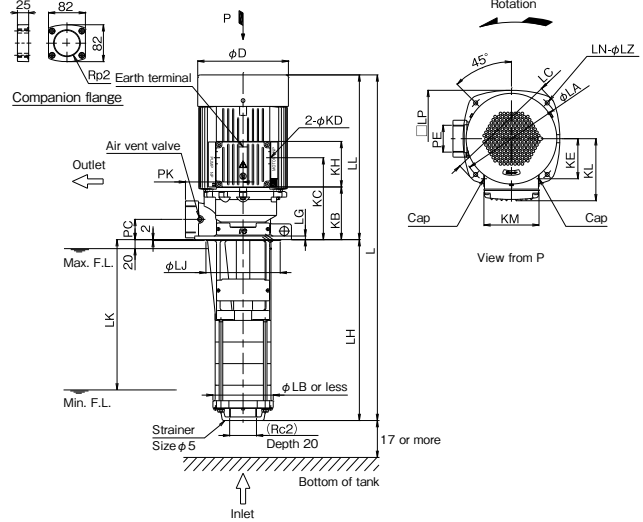
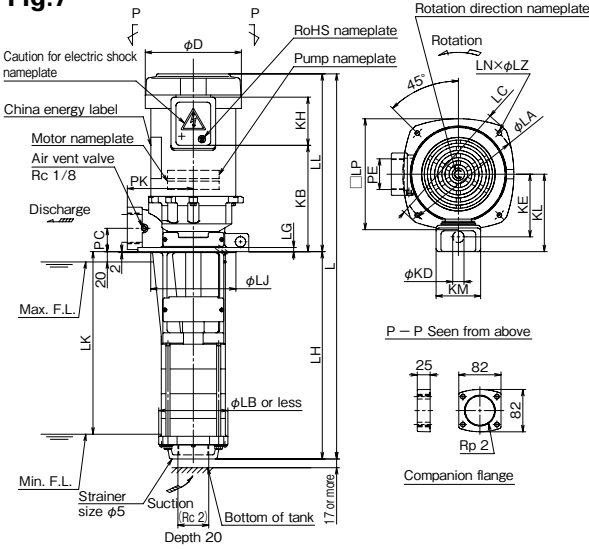

Fig.7



Dimensions

(Unit : mm)

Type	Fig.	D	KB	KC	KD	KE	KH	KL	KM	KN	L	LA	LB	LC	LG	LH	LJ	LL	LK	LN	LP	LZ	PC	PE	PK	Approx. mass (kg)
VKD111AA	1	162	139	—	22	109	93	137	87	—	530	215	161	239	8	258	165 <sup>0</sup> <sub>0.5</sub>	273	190	4	215	13	40	Rp1½	130	24.0
VKD111AA-G	2	162	139	—	22	105	93	142	87	28	530	215	161	239	8	258	165 <sup>0</sup> <sub>0.5</sub>	272	190	4	215	13	40	Rp1½	130	24.0
VKD111AA-GS	2	162	139	—	27	112	93	150	94	29	530	215	161	239	8	258	165 <sup>0</sup> <sub>0.5</sub>	272	190	4	215	13	40	Rp1½	130	24.0
VKD131AB	3	202	87	152	27	89	102	138	123	—	594	215	161	239	8	258	165 <sup>0</sup> <sub>0.5</sub>	336	190	4	215	13	40	Rp1½	130	34.0
VKD131AB-G	4	187	176	—	22	122	94	151	87	—	573	215	161	239	8	258	165 <sup>0</sup> <sub>0.5</sub>	315	190	4	215	13	40	Rp1½	130	34.0
VKD131AB-GS	4	187	176	—	27	125	94	164	94	—	573	215	161	239	8	258	165 <sup>0</sup> <sub>0.5</sub>	315	190	4	215	13	40	Rp1½	130	34.0
VKD131AF	6	202	117	182	27	89	102	138	123	—	768	225	161	250	8	402	165 <sup>0</sup> <sub>0.5</sub>	366	334	4	215	9	45	Rp2	128	39.0
VKD131AF-G	7	187	206	—	22	122	94	151	87	—	747	225	161	250	8	402	165 <sup>0</sup> <sub>0.5</sub>	345	354	4	215	9	45	Rp2	128	40.0
VKD131AF-GS	7	187	206	—	27	125	94	164	94	—	747	225	161	250	8	402	165 <sup>0</sup> <sub>0.5</sub>	345	354	4	215	9	45	Rp2	128	40.0
VKD141AC	3	202	87	152	27	89	102	138	123	—	594	215	161	239	8	258	165 <sup>0</sup> <sub>0.5</sub>	336	190	4	215	13	40	Rp1½	130	36.0
VKD141AC-G	3	202	87	152	27	89	102	138	123	—	594	215	161	239	8	258	165 <sup>0</sup> <sub>0.5</sub>	336	190	4	215	13	40	Rp1½	130	36.0
VKD141AC-GS	3	202	87	152	27	89	102	138	123	—	594	215	161	239	8	258	165 <sup>0</sup> <sub>0.5</sub>	336	190	4	215	13	40	Rp1½	130	36.0
VKD141AG	6	202	117	182	27	89	102	138	123	—	768	225	161	250	8	402	165 <sup>0</sup> <sub>0.5</sub>	366	334	4	215	9	45	Rp2	128	41.0
VKD141AG-G	6	202	117	182	27	89	102	138	123	—	768	225	161	250	8	402	165 <sup>0</sup> <sub>0.5</sub>	366	334	4	215	9	45	Rp2	128	43.0
VKD141AG-GS	6	202	117	182	27	89	102	138	123	—	768	225	161	250	8	402	165 <sup>0</sup> <sub>0.5</sub>	366	334	4	215	9	45	Rp2	128	43.0
VKD151AD	5	202	87	152	27	89	102	138	123	—	642	215	161	239	8	306	165 <sup>0</sup> <sub>0.5</sub>	336	238	4	215	13	40	Rp1½	130	39.0
VKD151AD-G	5	202	87	152	27	89	102	138	123	—	642	215	161	239	8	306	165 <sup>0</sup> <sub>0.5</sub>	336	238	4	215	13	40	Rp1½	130	39.0
VKD151AD-GS	5	202	87	152	27	89	102	138	123	—	642	215	161	239	8	306	165 <sup>0</sup> <sub>0.5</sub>	336	238	4	215	13	40	Rp1½	130	39.0
VKD151AH	6	202	117	182	27	89	102	138	123	—	768	225	161	250	8	402	165 <sup>0</sup> <sub>0.5</sub>	366	344	4	215	9	45	Rp2	128	44.0
VKD151AH-G	6	202	117	182	27	89	102	138	123	—	768	225	161	250	8	402	165 <sup>0</sup> <sub>0.5</sub>	366	334	4	215	9	45	Rp2	128	44.0
VKD151AH-GS	6	202	117	182	27	89	102	138	123	—	768	225	161	250	8	402	165 <sup>0</sup> <sub>0.5</sub>	366	334	4	215	9	45	Rp2	128	44.0



#### Sectional drawing

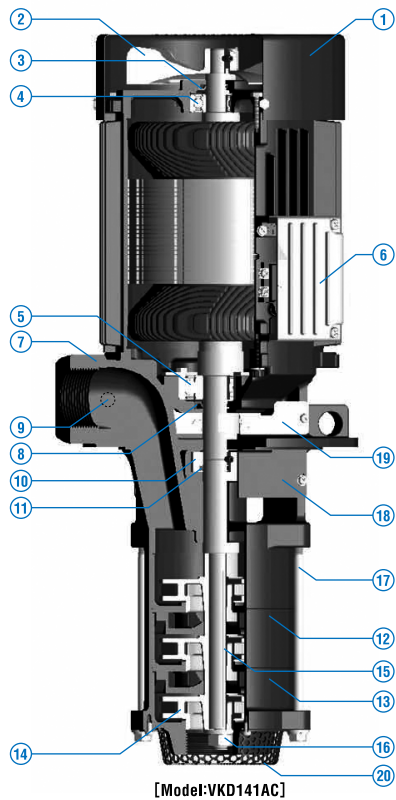

No.	Parts Name	Materials
1	Fan cover	SPCE
2	External fan	Resin
3	Oil seal	NBR
4	Deep groove ball bearing	
5	Deep groove ball bearing	
6	Terminal box	SPCC or ADC12
7	Pump leg	FC200
8	Oil seal	NBR
9	Air vent valve	SUS
10	Oil thrower	SUS304
11	O-ring	Fluoro rubber
12	Casing	FC200
13	Casing	FC200
14	Impeller	FC200
15	Key	S45C-D
16	Hexagon nut	SS/plated
17	Fastening bolt	SS/plated
18	Side plate	SPCC
19	Side plate	SPCC/plated
20	Wide strainer	SPCC

Note: Structure and other details are subject to change without notice.

**Features**

- ① Not easily affected by dirty coolants
- ② The impeller is made of FCD and highly durable
- ③ Adjust the operating coolant level as preferred, by connecting the intake piping for these pumps
- ④ Can be used for highly viscous coolants
- ⑤ China energy label regulation (GB18613-2012) efficiency-compliant unit (grade GB3) available

**Structure**

Non-seal (mechanical seal-less) structure. Cast iron is used in the pump's main unit.

**How to read the model type**

**LPW 65 3 /2 A - 6 7.5**

① ② ③ ④ ⑤ ⑥ ⑦ ⑧

- ① Model
- ② Pump's bore diameter
- ③ Number of stages
- ④ Number of impellers  
(Not provided when equal to the number of stages)
- ⑤ Level of viscosity to be used with  
(A, C: For low viscosity, D: For high viscosity)
- ⑥ Frequency  
(5: 50Hz, 6: 60Hz, no description: For both 50/60Hz)
- ⑦ Output
- ⑧ Compliance with energy efficiency regulation (no description: standard  
-G: China energy label regulation (GB18613-2012) efficiency-compliant unit (grade GB3) (200V, 50Hz)  
-GS: China energy label regulation (GB18613-2012) efficiency-compliant unit (grade GB3) (380V, 50Hz)



**Selection chart (performance drawings)**

● For low viscosity coolants (The following curves show performance of pump under condition of normal temperature freshwater with specific gravity of 1.)

50Hz

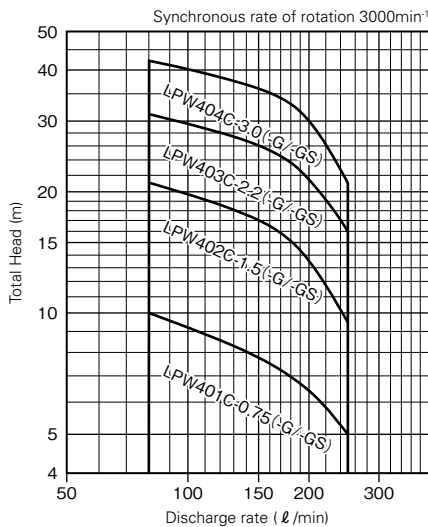

60Hz

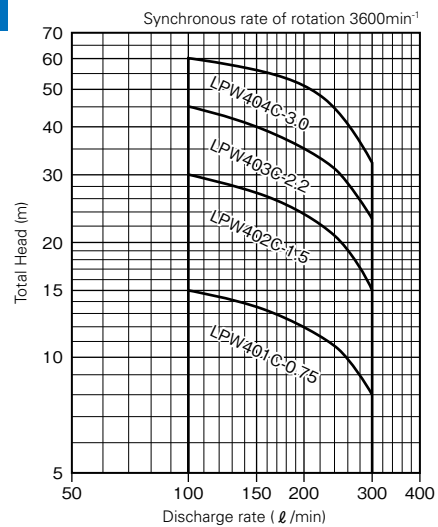

● For high viscosity coolants (The following curves show performance of pump under condition of 150cSt viscosity and specific gravity of 1.)

50Hz

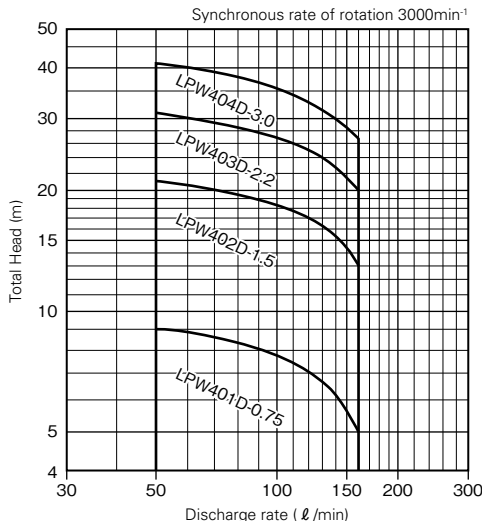

60Hz

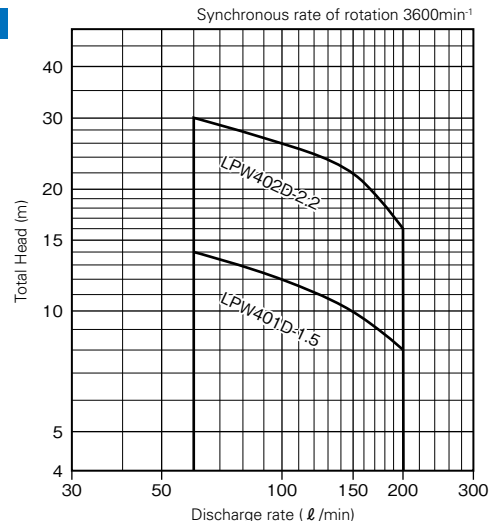

### Specifications

#### 50Hz

Type		Models for low viscosity coolants				Models for high viscosity coolants				
		LPW401C-0.75	LPW402C-1.5	LPW403C-2.2	LPW404C-3.0	LPW401D-0.75	LPW402D-1.5	LPW403D-2.2	LPW404D-3.0	
Pump	Bore diameter (mm)	40								
	Discharge rate (ℓ/min)	80~250				50~160				
	Total head (m)	10~5	21~9.5	31~16	42~21	9~5	21~13	31~20	41~27	
	Max. viscosity allowed (mm <sup>2</sup> /s)	32				150				
	Phases	3								
Motor	No. of poles (P)	2								
	Rated output (kW)	0.75	1.5	2.2	3.0	0.75	1.5	2.2	3.0	
	Rated voltage (V)	200								
	Rated current (A)	3.5	6.5	8.8	12.0	3.5	6.5	8.8	12.0	
	Synchronous rate of rotation (min <sup>-1</sup> )	3000								
	Insulation class	E								
	Rating	Continuous								
	Method of protection	Totally enclosed fan cooled, indoor								
	Bearings	Load side	6306ZZ			6307ZZ	6306ZZ			6307ZZ
		Non-load side	6204ZZ	6205ZZ		6206ZZ	6204ZZ	6205ZZ		6206ZZ
	Ambient temperature (°C)	40 or below								
	Paint color	Munsell N1.5								

#### China energy label regulation (GB18613-2012) efficiency-compliant unit (grade GB3)

Type		Models for low viscosity coolants								
		LPW401C-0.75-G	LPW402C-1.5-G	LPW403C-2.2-G	LPW404C-3.0-G	LPW401C-0.75-GS	LPW402C-1.5-GS	LPW403C-2.2-GS	LPW404C-3.0-GS	
Pump	Bore diameter (mm)	40								
	Discharge rate (ℓ/min)	80~250								
	Total head (m)	10~5	21~9.5	31~16	42~21	10~5	21~9.5	31~16	42~21	
	Max. viscosity allowed (mm <sup>2</sup> /s)	32								
	Phases	3								
Motor	No. of poles (P)	2								
	Rated output (kW)	0.75	1.5	2.2	3.0	0.75	1.5	2.2	3.0	
	Rated voltage (V)	200				380				
	Rated current (A)	3.8	6.1	8.9	14.3	2.0	3.3	5.2	7.5	
	Synchronous rate of rotation (min <sup>-1</sup> )	3000								
	Insulation class	F								
	Rating	Continuous								
	Method of protection	Totally enclosed fan cooled, indoor								
	Bearings	Load side	6306ZZC3			6307ZZC3	6306ZZC3			6307ZZC3
		Non-load side	6203ZZC3	6303ZZC3		6205ZZC3	6203ZZC3	6303ZZC3		6205ZZC3
	Ambient temperature (°C)	40 or below								
	Paint color	Munsell N1.5								

With pumps for high viscosity coolants, contact us for further details.

#### 60Hz

Type		Models for low viscosity coolants				Models for high viscosity coolants		
		LPW401C-0.75	LPW402C-1.5	LPW403C-2.2	LPW404C-3.0	LPW401D-1.5	LPW402D-2.2	
Pump	Bore diameter (mm)	40						
	Discharge rate (ℓ/min)	100~300				60~200		
	Total head (m)	15~8	30~15	45~23	60~32	14~8	30~16	
	Max. viscosity allowed (mm <sup>2</sup> /s)	32				150		
	Phases	3						
Motor	No. of poles (P)	2						
	Rated output (kW)	0.75	1.5	2.2	3.0	1.5	2.2	
	Rated voltage (V)	200/220						
	Rated current (A)	3.5/3.4	6.5/6.1	9.0/8.2	11.5/10.7	6.5/6.1	9.0/8.2	
	Synchronous rate of rotation (min <sup>-1</sup> )	3600						
	Insulation class	E						
	Rating	Continuous						
	Method of protection	Totally enclosed fan cooled, indoor						
	Bearings	Load side	6306ZZ			6307ZZ	6306ZZ	
		Non-load side	6204ZZ	6205ZZ		6206ZZ	6205ZZ	
	Ambient temperature (°C)	40 or below						
	Paint color	Munsell N1.5						

※ These pumps work with coolants containing an additive (anticorrosive, etc.), for instance water-soluble and water-insoluble coolants. Do not, however, use these pumps with freshwater.

### Special specifications

- Can be used for high viscosity coolants
- Sealing structure is modified (to improve abrasion resistance)

Selection chart (performance drawings)

(The following curves show performance of pump under condition of normal temperature freshwater with specific gravity of 1.)

50Hz

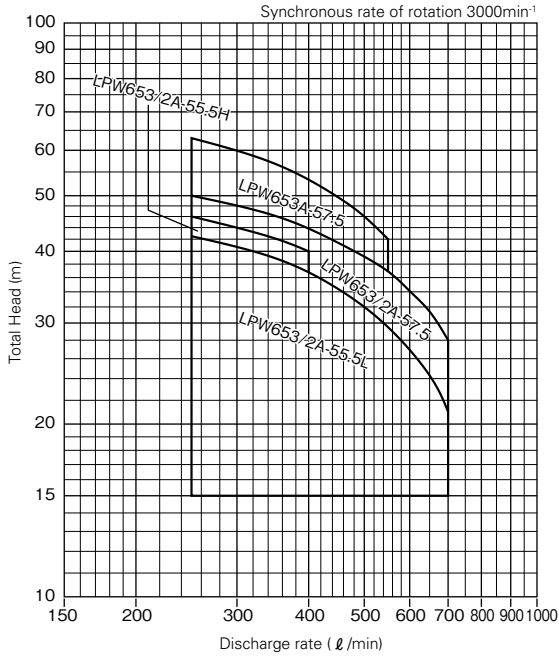

50Hz

Type		LPW653/2A-55.5L	LPW653/2A-55.5H	LPW653/2A-57.5	LPW653A-57.5
Pump	Bore diameter (mm)	65			
	Discharge rate (ℓ/min)	250~700	250~400	250~700	250~550
	Total head (m)	42.5~21	46~40	50~28	63~42
	Coolants to be used	Water-soluble coolants			
Motor	Phases	3			
	No. of poles (P)	2			
	Output (kW)	5.5		7.5	
	Voltage (V)	200			
	Rated current (A)	21		27.8	
	Synchronous rate of rotation (min <sup>-1</sup> )	3000			
	Insulation class	B			
	Ambient temperature (°C)	40 or below			
	Rating	Continuous			
	Method of protection	Totally enclosed fan cooled, indoor			
Bearings	Load side	6308ZZ			
	Non-load side	6306ZZ			
Paint color		Munsell N1.5			

\* For China energy label regulation (GB18613-2012) efficiency-compliant unit (grade GB3), contact us for further details.

60Hz

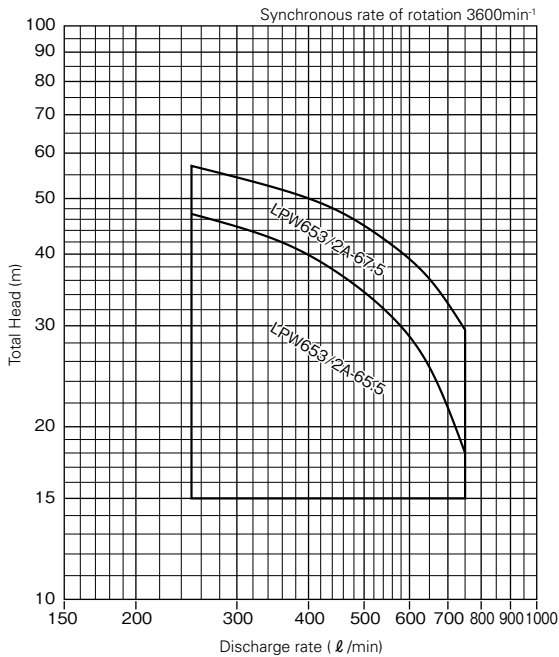

60Hz

Type		LPW653/2A-65.5	LPW653/2A-67.5
Pump	Bore diameter (mm)	65	
	Discharge rate (ℓ/min)	250~750	250~750
	Total head (m)	47~18	57~29.5
Coolants to be used		Water-soluble coolants	
Motor	Phases	3	
	No. of poles (P)	2	
	Output (kW)	5.5	7.5
	Voltage (V)	200/220	
	Rated current (A)	20	26.6
	Synchronous rate of rotation (min <sup>-1</sup> )	3600	
	Insulation class	B	
	Ambient temperature (°C)	40 or below	
	Rating	Continuous	
	Method of protection	Totally enclosed fan cooled, indoor	
Bearings	Load side	6308ZZ	
	Non-load side	6306ZZ	
Paint color		Munsell N1.5	

#### Assembly Drawing

●LPW40

Fig.1

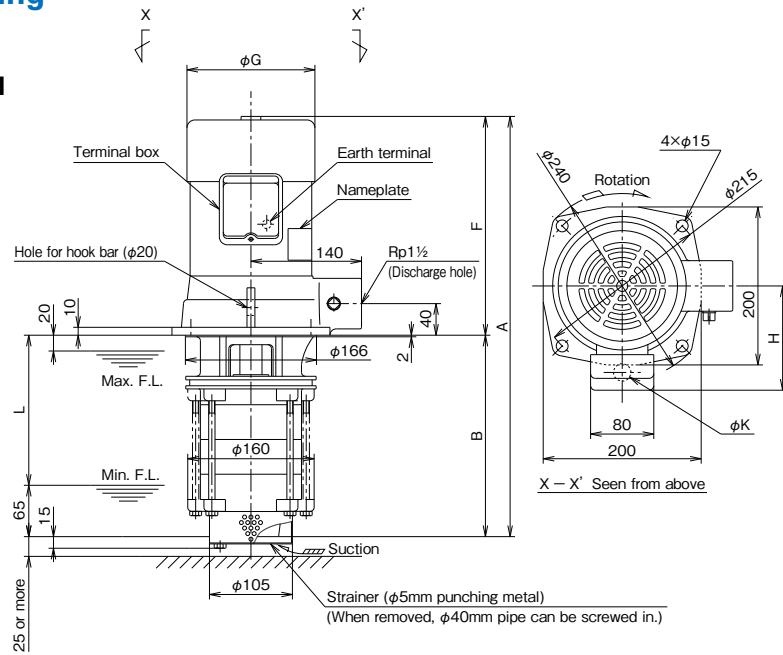
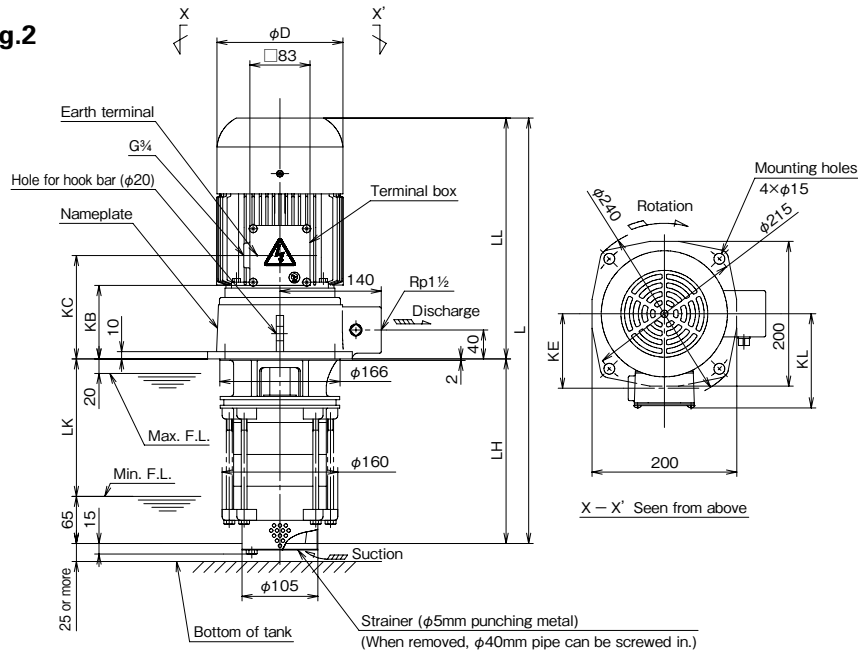

Fig.2



#### Dimensions

●LPW40

(Unit : mm)

		Type	Fig.	D	KB	KC	KD	KE	KL	L	LH	LK	LL	Approx. mass (kg)	
For low viscosity coolants	For both 50Hz and 60Hz	LPW401C-0.75	1	162	-	-	22	-	132	532	255	190	277	31	
		LPW402C-1.5		184					141	555			300	35	
		LPW403C-2.2		215					158	579			324	43	
		LPW404C-3.0							674	299			234	375	55
	50 Hz	LPW401C-0.75-G	2	140	102	143	-	103	88	115	543	255	190	288	37
		LPW401C-0.75-GS													
		LPW402C-1.5-G													
		LPW402C-1.5-GS													
		LPW403C-2.2-G													
		LPW403C-2.2-GS													
60 Hz	LPW404C-3.0-G	195	103	145	-	113	140	663	299	234	364	364	57		
	LPW404C-3.0-GS														
For high viscosity coolants	50 Hz	LPW401D-0.75	1	162	-	-	22	-	132	532	255	190	277	31	
		LPW402D-1.5		184					141	555			300	35	
		LPW403D-2.2		215					158	579			324	43	
		LPW404D-3.0							674	299			234	375	55
	60 Hz	LPW401D-1.5	184	-	-	22	-	141	555	255	190	300	324	34	
		LPW402D-2.2													579

Assembly Drawing

●LPW65

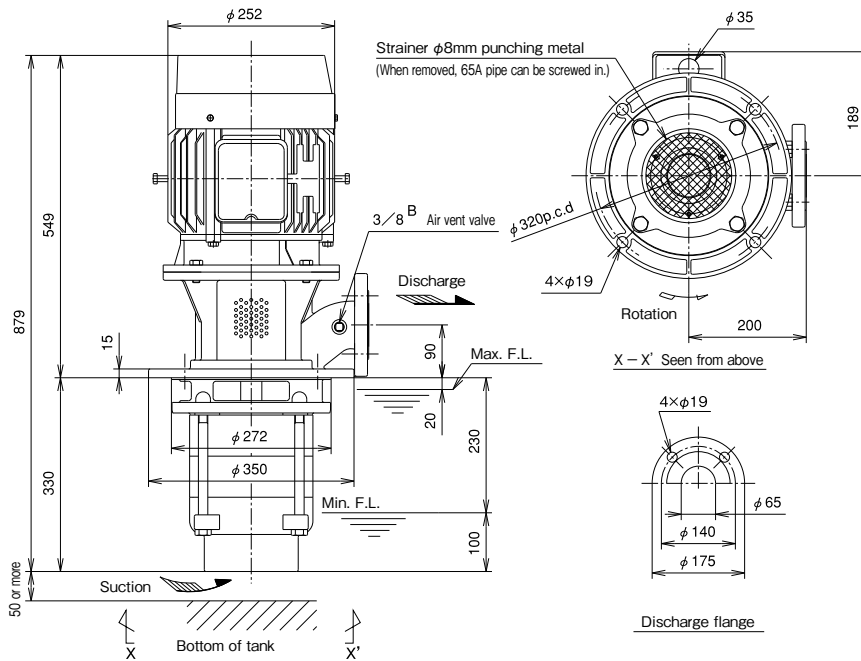

Dimensions

●LPW65

	Type	Bore diameter (mm)	Output (kW)	Approx. mass (kg)
50 Hz	LPW653/2A-55.5L	65	5.5	105
	LPW653/2A-55.5H			105
	LPW653/2A-57.5		7.5	107
	LPW653A-57.5			109
60 Hz	LPW653/2A-65.5		7.5	105
	LPW653/2A-67.5			107

\* For China energy label regulation (GB18613-2012) efficiency-compliant unit (grade GB3), contact us for further details.

### Sectional drawing

#### ●LPW40

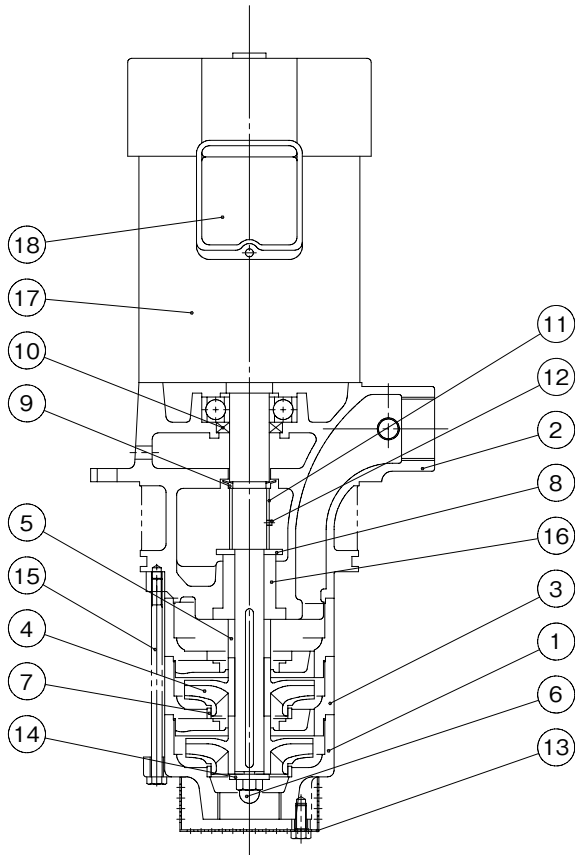

No.	Parts Name	Qty	Materials
1	Suction casing	1	FC200
2	Discharge casing	1	FC200
3	Intermediate casing	2	FC200
4	Impeller	2	FCD450
5	Shaft spacer	1	STS
6	Impeller nut	1	SUS304
7	Wearing ring	2	SUS304
8	Deflector	1	SS400
9	Deflector	1	NBR
10	Oil seal	1	NBR
11	Collar	1	STKM
12	Hexagon socket set screw	1	SCM435
13	Strainer	1	SPCC
14	Washer	1	SUS420J1
15	Tie bolt	4	SS400
16	Shaft sleeve	1	FCD450
17	Motor	1	
18	Terminal box	1	SECC

Applicable models: LPW402C-1.5 · LPW402D-1.5 · LPW402D-2.2

#### ●LPW65

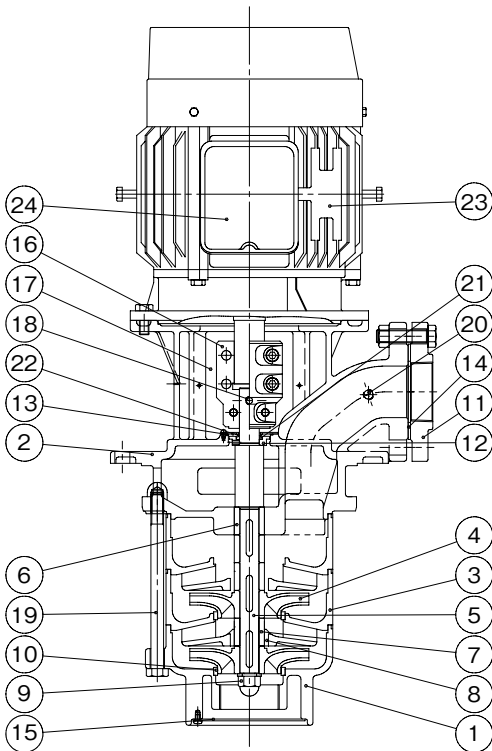

No.	Parts Name	Qty	Materials
1	Suction casing	1	FC200
2	Discharge casing	1	FC200
3	Intermediate casing	2	FC200
4	Impeller	2	FCD450
5	Shaft	1	S45C
6	Shaft sleeve A	3	SUS304
7	Shaft sleeve B	1	SIC
8	Intermediate bush	1	SIC
9	Impeller nut	1	SUS304
10	Wearing ring	3	SUS304
11	Companion flange	1	FC200
12	Deflector	1	C3604B
13	O-ring	1	NBR
14	Sheet packing	1	NBR
15	Strainer	1	SPCC
16	Coupling	1	FC200
17	Coupling cover	2	SUS304
18	Hexagon socket set screw	1	SCM435
19	Tie bolt	4	SS400
20	Plug	1	SS400
21	V-ring	1	VITON
22	Coolant sealing plate	1	SUS304
23	Motor	1	ADC
24	Terminal box	1	SPCC

Applicable models: 50Hz LPW653/2A-55.5L, LPW653/2A-55.5H, LPW653/2A-57.5  
60Hz LPW653/2A-65.5, LPW653/2A-67.5



**Features**

- ① All of LKW Pump lengths below the base are as short as 330 mm. This allows for standardization of the tanks
- ② Used in a serial operation, these models can generate up to 3.92Mpa (40kgf/cm<sup>2</sup>)
- ③ Adjust the operating coolant level as preferred, by connecting the intake piping for these pumps  
Figures in ( ) are for reference only

**Structure**

Non-seal (mechanical seal-less) structure. Stainless steel and special resin with high reliability are used in the pump's main unit.

**How to read the model type**

**LKW 20 09 -6 3.0 D**

- ①      ②      ③      ④      ⑤      ⑥

- ① Model
- ② Pump's bore diameter
- ③ Number of impellers
- ④ Frequency (5: 50Hz, 6: 60Hz)
- ⑤ Output
- ⑥ Operation method (No description: independent operation, D: serial operation)

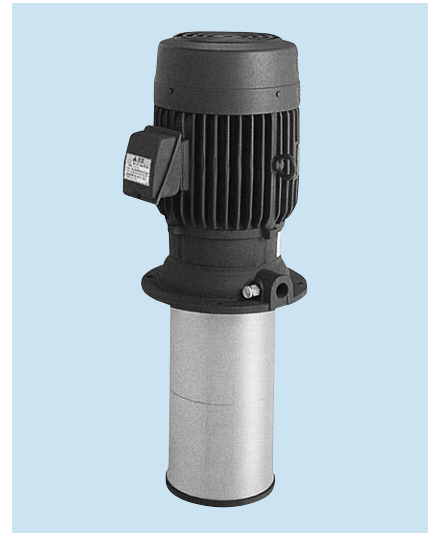

**Selection chart (performance drawings)**

(The following curves show performance of pump under condition of normal temperature freshwater with specific gravity of 1.)

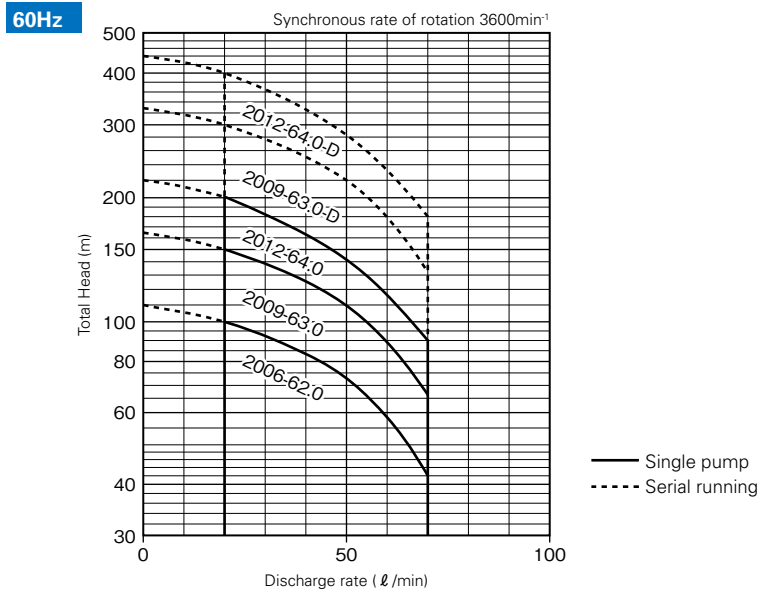
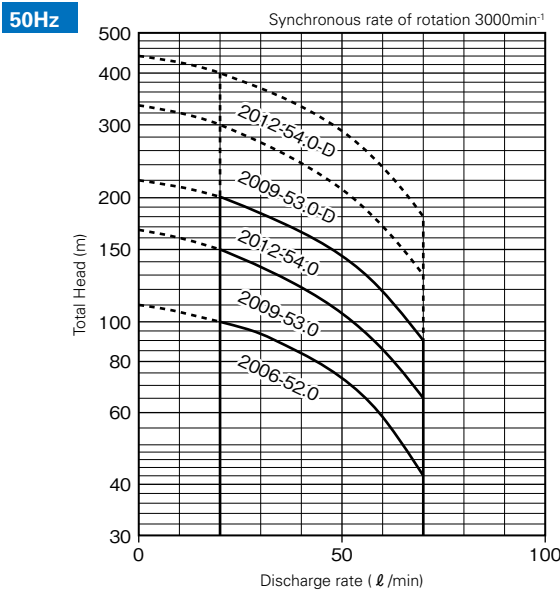

**Specifications**

Type		50Hz					60Hz				
		LKW2006-52.0	LKW2009-53.0	LKW2012-54.0	LKW2009-53.0-D	LKW2012-54.0-D	LKW2006-62.0	LKW2009-63.0	LKW2012-64.0	LKW2009-63.0-D	LKW2012-64.0-D
Pump	Bore diameter (mm)	20					20				
	Discharge rate (l/min)	20~70					20~70				
	Total head (m)	100~42	150~65	200~90	300~130	400~180	100~43	150~67	200~90	300~134	400~180
Coolants to be used		Water-soluble coolants					Water-soluble coolants				
Motor	Phases	3					3				
	No. of poles (P)	2					2				
	Rated output (kW)	2.2	3.0	4.0	3.0×2	4.0×2	2.2	3.0	4.0	3.0×2	4.0×2
	Rated voltage (V)	200					200/220				
	Rated current (A)	8.8	12.4	15.7	12.4×2	15.7×2	9.0/8.4	12.0/11.2	15.4/14.5	12.0×2/11.2×2	15.4×2/14.5×2
	Synchronous rate of rotation (min <sup>-1</sup> )	3000					3600				
	Insulation class	F					F				
	Rating	Continuous					Continuous				
	Method of protection	Totally enclosed fan cooled, indoor					Totally enclosed fan cooled, indoor				
	Bearings	Load side	6306ZZC3	6308ZZC3	6308ZZC3	6308ZZC3	6308ZZC3	6306ZZC3	6308ZZC3	6308ZZC3	6308ZZC3
	Non-load side	6303ZZC3	6205ZZC3			6303ZZC3	6205ZZC3				
Ambient temperature (°C)		40 or below					40 or below				
Paint color		Munsell N1									

### Assembly Drawing

#### Single pump

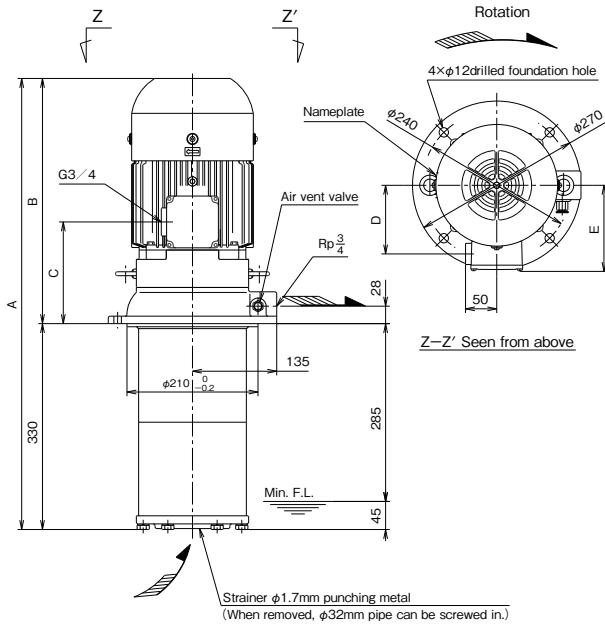

#### Serial running

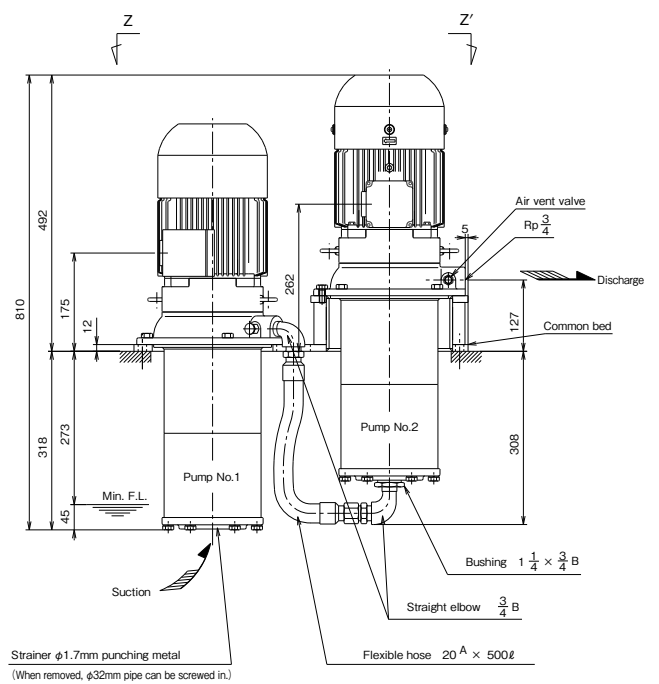

### Dimensions

#### Single pump

(Unit : mm)

Type	Frequency	A	B	C	D	E	Approx. mass (kg)
LKW2006-52.0	50Hz	693	363	158	100	128	47
LKW2009-53.0		723	393	163	110	138	51
LKW2012-54.0		723	393	163	110	138	63
LKW2006-62.0	60Hz	693	363	158	100	128	47
LKW2009-63.0		723	393	163	110	138	51
LKW2012-64.0		723	393	163	110	138	63

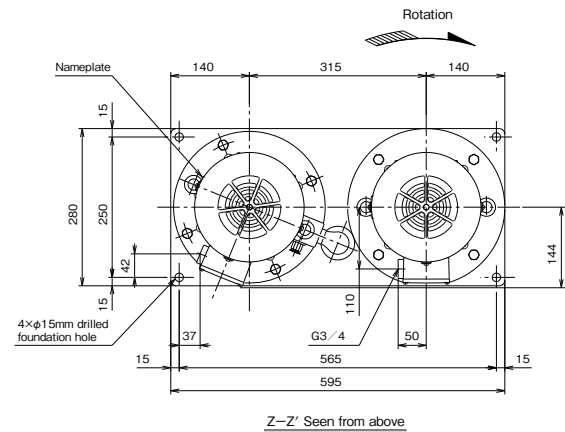

### Dimensions

#### Serial running

Type	Frequency	Approx. mass (kg)
LKW2009-53.0-D	50Hz	124
LKW2012-54.0-D		148
LKW2009-63.0-D	60Hz	124
LKW2012-64.0-D		148

In the case of serial running, we ship the pumps and the accompanying components in separate packages. Please assemble them at your site.

## Sectional drawing

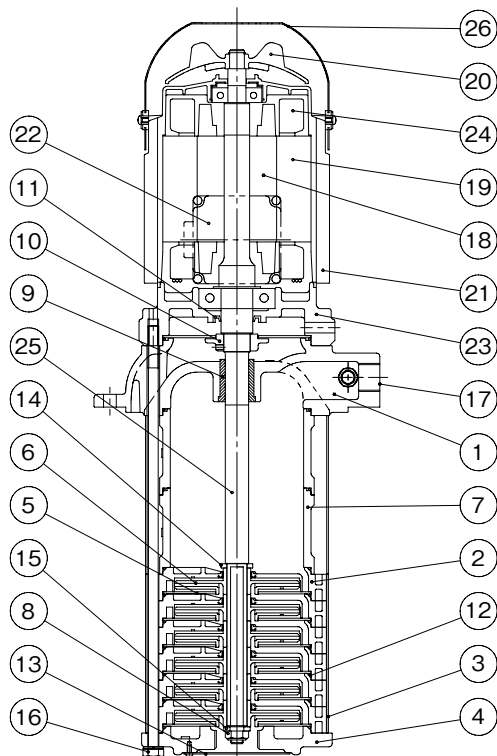

No.	Parts Name	Qty	Materials
1	Discharge casing	1	FC200
2	Intermediate casing	n	ARLS+(SUS304)
3	Outer casing	2	SUS304
4	Suction cover	1	FC200
5	Casing cover	n+1	SUS304
6	Impeller	n	ARLS
7	Intermediate spacer	※1	FC200
8	Impeller nut	1	SUS304
9	Bushing	1	SUS420J2
10	Deflector	1	FC200
11	Oil seal	1	NBR
12	O-ring	※2	NBR
13	Strainer	1	SUS304
14	Supporter ring	1	SUS403
15	Washer	1	SUS403
16	Tie bolt	6	SS400
17	Air vent valve	1	C3604BD
18	Rotor	1	S40
19	Stator	1	S40
20	Cooling fan	1	Plastic (PP)
21	Motor frame	1	ADC
22	Terminal box	1	ADC(※3)
23	Lower bracket	1	FC200
24	Stator winding	1	EIW
25	Motor bearing	1	S35C
26	Fan cover	1	SECE

n: Number of stages

※1 2.0 kW: 2, 3.0 kW: 1, 4.0 kW: 0

※2 2.0 kW: 10, 3.0 kW: 12, 4.0 kW: 14

※3 Terminal box cover is SECE

#### Features

- ① Mechanical seal-less structure
- ② EU RoHS Directive (Restriction of Use of Six Hazardous Substances)compliant
- ③ European Standards (EN) compliant
  - EU Directives for CE marking
  - IEC-compatible terminal box
- ④ China energy label regulation (GB18613-2012) efficiency-compliant unit (grade GB3) available
- ⑤ Impellers designed for high-frequency operation
- ⑥ Enhanced protection against mist and other environmental elements
  - IP54 protection
  - Oil seals in the motor
- ⑦ Energy-saving operation by the inverter(flow rate adjusting, etc.) (10 to 60Hz)

Note: Resonance may occur arbitrarily when the unit is operated at variable speeds using the inverter. Operate the unit avoiding the resonance points.

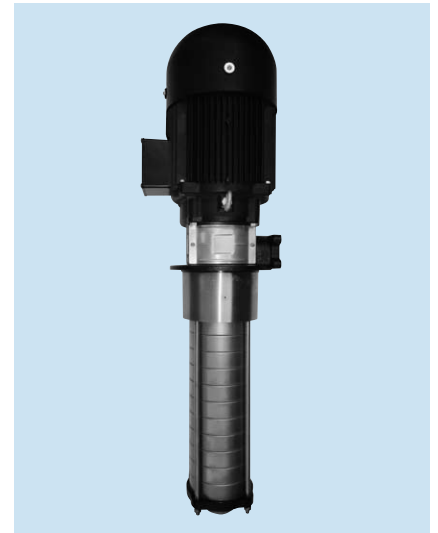

#### Structure

Non-seal (mechanical seal-less) structure. Aluminum frame is used in the motor section and stainless steel is used in the pump's main unit. Special coupling is used for the connection.

#### How to read the model type

**VKB 19 26 2 A H**

①    ②    ③    ④    ⑤    ⑥    ⑦

- ① Model
- ② Number of impellers
- ③ Number of stages
- ④ Series
- ⑤ Number of phases · Frequency (A: 3 phases, 50/60Hz; F: 3 phases, 50Hz exclusive)
- ⑥ Characteristics (H: pressure type)
- ⑦ Efficiency regulation-compliant (No mark: standard)
  - G: China energy label regulation (GB18613-2012) efficiency-compliant unit (grade GB3) (200V, 50Hz)
  - GS: China energy label regulation (GB18613-2012) efficiency-compliant unit (grade GB3) (380V, 50Hz)

#### Selection chart (performance drawings)

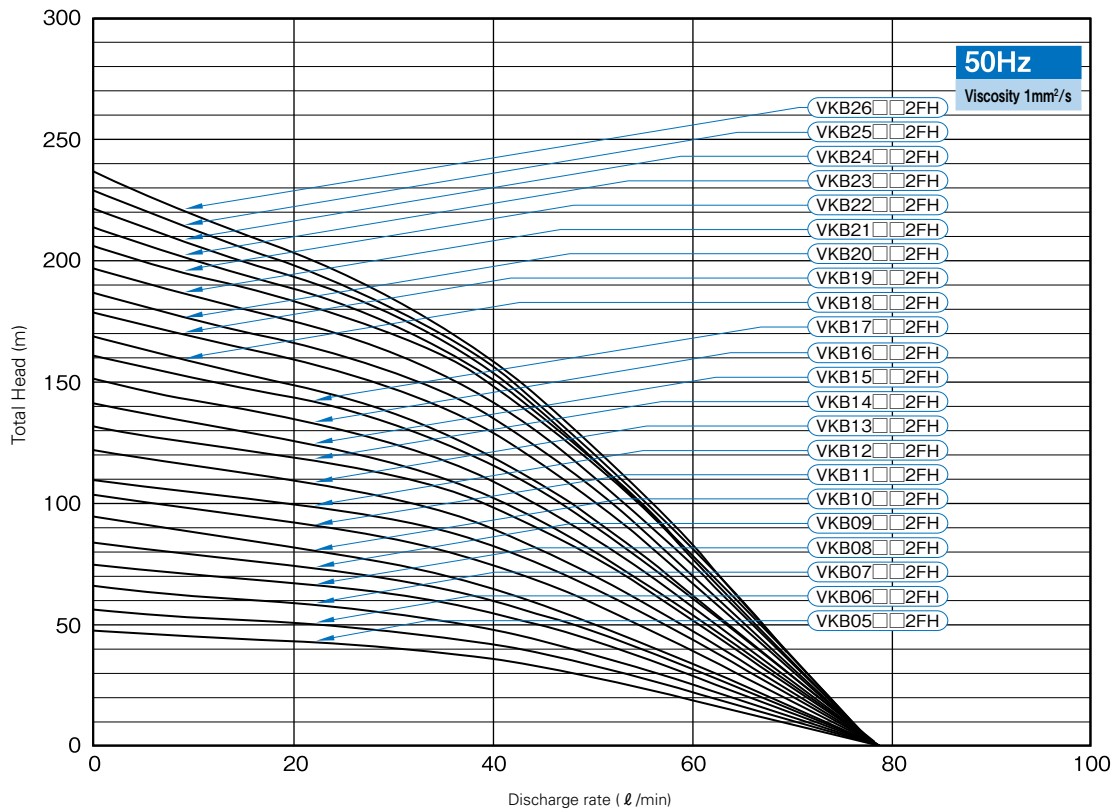

Note: The above characteristic curves reflect the full impeller condition of the units. The total head may be decreased depending on the flow rate if empty casings are involved because of pressure loss at the empty casings.

Selection chart (performance drawings)

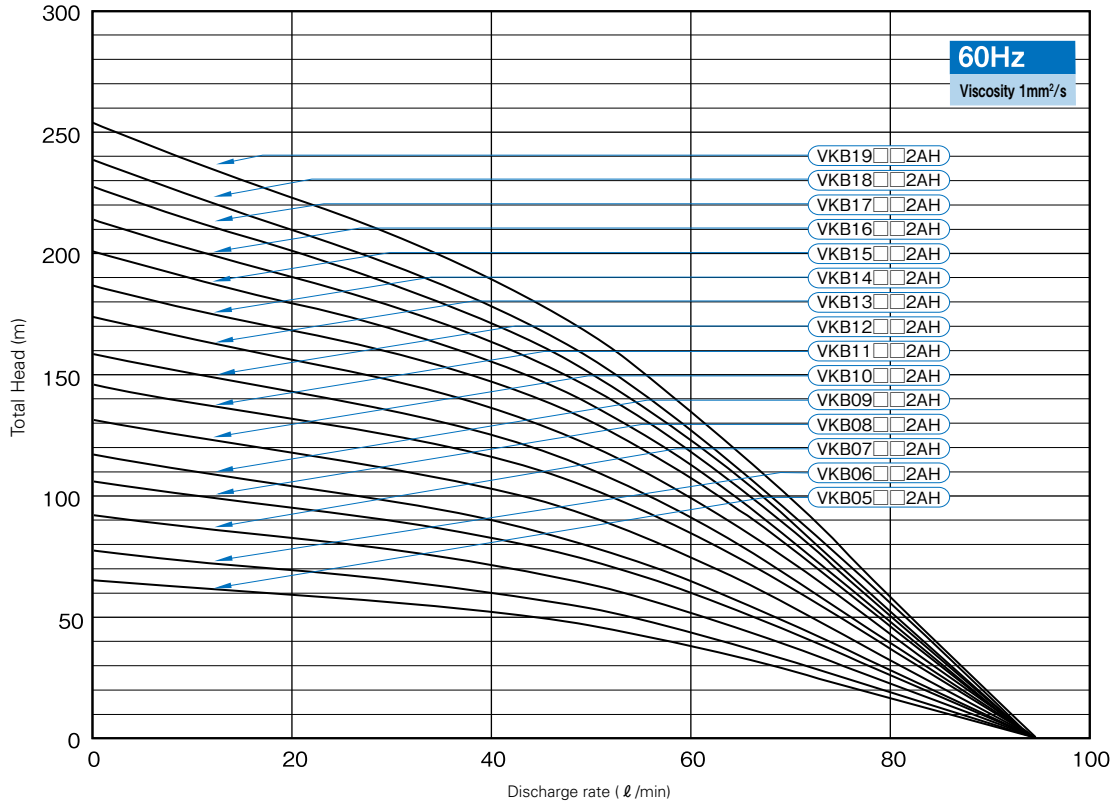

Notes 1.The above characteristic curves reflect the full impeller condition of the units. The total head may be decreased depending on the flow rate if empty casings are involved because of pressure loss at the empty casings.  
2.The performance significantly varies according to the type of liquid circulated and the liquid's viscosity. Depending on the viscosity or specific weight, some types of liquid cannot be used.

Specifications

Specifications	Type	VKB05□□2AH	VKB06□□2AH	VKB07□□2AH	VKB08□□2AH	VKB09□□2AH	VKB10□□2AH	VKB11□□2AH	VKB12□□2AH								
Nominal output	(W)	0.5	0.85	0.6	1.02	0.7	1.19	0.8	1.36	0.9	1.53	1.0	1.7	1.1	1.87	1.2	2.04
Rated voltage	(V)	200	200	200	200	200	200	200	200	200	200	200	200	200	200	200	200
Frequency	(Hz)	50	60	50	60	50	60	50	60	50	60	50	60	50	60	50	60
Rated current	(A)	5.2	5.8	5.7	6.7	6.2	7.1	6.6	8.8	7.2	10.0	10.3	10.3	10.6	11.1	11.0	11.8
Discharge rate	(l/min)	40	50	40	50	40	50	40	50	40	50	40	50	40	50	40	50
Total head	(m)	30	40	36	48	42	56	48	64	54	72	60	80	66	88	72	96
Max. viscosity allowed	(mm²/s)	75	75	75	75	75	37.5	75	75	75	75	75	75	75	75	75	75
Outlet	(Rp)	1¼															
Paint color		Munsell N1															
Standard		IEC60034-1 CE approved															
Degree of protection		IP54															

Specifications	Type	VKB13□□2AH	VKB14□□2AH	VKB15□□2AH	VKB16□□2AH	VKB17□□2AH	VKB18□□2AH	VKB19□□2AH							
Nominal output	(W)	1.3	2.21	1.4	2.38	1.5	2.55	1.6	2.72	1.7	2.89	1.8	3.06	1.9	3.23
Rated voltage	(V)	200	200	200	200	200	200	200	200	200	200	200	200	200	200
Frequency	(Hz)	50	60	50	60	50	60	50	60	50	60	50	60	50	60
Rated current	(A)	11.5	12.7	11.9	13.5	12.4	14.4	12.9	15.3	13.4	16.2	14.0	17.1	14.6	18.0
Discharge rate	(l/min)	40	50	40	50	40	50	40	50	40	50	40	50	40	50
Total head	(m)	78	104	84	112	90	120	96	128	102	136	108	144	114	152
Max. viscosity allowed	(mm²/s)	75	75	75	75	75	75	75	75	75	75	75	75	75	75
Outlet	(Rp)	1¼													
Paint color		Munsell N1													
Standard		IEC60034-1 CE approved													
Degree of protection		IP54													

Notes 1. Contact us when your applications involve special liquids (demineralized water, alkali/acidic liquids, etc.).  
2. Liquid temperature range -20 to +90°C (without freezing).  
\* For China energy label regulation (GB18613-2012) efficiency-compliant unit (grade GB3), contact us for further details.

### Specifications

#### ●[50Hz Exclusive]

Specifications	Type	VKB05□□2FH	VKB06□□2FH	VKB07□□2FH	VKB08□□2FH	VKB09□□2FH	VKB10□□2FH	VKB11□□2FH	VKB12□□2FH	VKB13□□2FH	VKB14□□2FH	VKB15□□2FH
Nominal output	(W)	0.5	0.6	0.7	0.8	0.9	1.0	1.1	1.2	1.3	1.4	1.5
Rated voltage	(V)	200	200	200	200	200	200	200	200	200	200	200
Rated current	(A)	3.6	4.0	4.5	5.8	6.3	6.9	6.6	7.0	7.5	7.9	8.4
Discharge rate	(ℓ/min)	40	40	40	40	40	40	40	40	40	40	40
Total head	(m)	30	36	42	48	54	60	66	72	78	84	90
Max. viscosity allowed	(mm <sup>2</sup> /s)	1	1	1	1	1	1	1	1	1	1	1
Outlet	(Rp)	1¼										
Paint color		Munsell N1										
Standard		IEC60034-1 CE approved										
Degree of protection		IP54										

Specifications	Type	VKB16□□2FH	VKB17□□2FH	VKB18□□2FH	VKB19□□2FH	VKB20□□2FH	VKB21□□2FH	VKB22□□2FH	VKB23□□2FH	VKB24□□2FH	VKB25□□2FH	VKB26□□2FH
Nominal output	(W)	1.6	1.7	1.8	1.9	2.0	2.1	2.2	2.3	2.4	2.5	2.6
Rated voltage	(V)	200	200	200	200	200	200	200	200	200	200	200
Rated current	(A)	8.9	9.4	10.0	10.5	12.0	12.3	12.6	13.0	13.4	13.8	14.2
Discharge rate	(ℓ/min)	40	40	40	40	40	40	40	40	40	40	40
Total head	(m)	96	102	108	114	120	126	132	138	144	150	156
Max. viscosity allowed	(mm <sup>2</sup> /s)	1	1	1	1	1	1	1	1	1	1	1
Outlet	(Rp)	1¼										
Paint color		Munsell N1										
Standard		IEC60034-1 CE approved										
Degree of protection		IP54										

- Notes 1. The 50Hz exclusive units are for use with water-soluble liquids (1mm<sup>2</sup>/s kinematic viscosity) only. Contact us when your applications involve oil-based liquids.  
 2. Contact us when your applications involve special liquids(demineralized water, alkali/acidic liquids, etc.).  
 3. Liquid temperature range -20 to +90°C (without freezing).

\* For China energy label regulation (GB18613-2012) efficiency-compliant unit (grade GB3), contact us for further details.

### Special specifications

Motor modifications	Change in voltage, change in position of terminal box, change in direction of terminal box
Change in structure	Stainless-steel suction chamber*

※Models are subject to change. “-SU” is added as a suffix.

Note: The suction chamber is not 100% made of stainless steel. Pump legs and companion flanges are made of cast iron.

Assembly Drawing

Fig.1

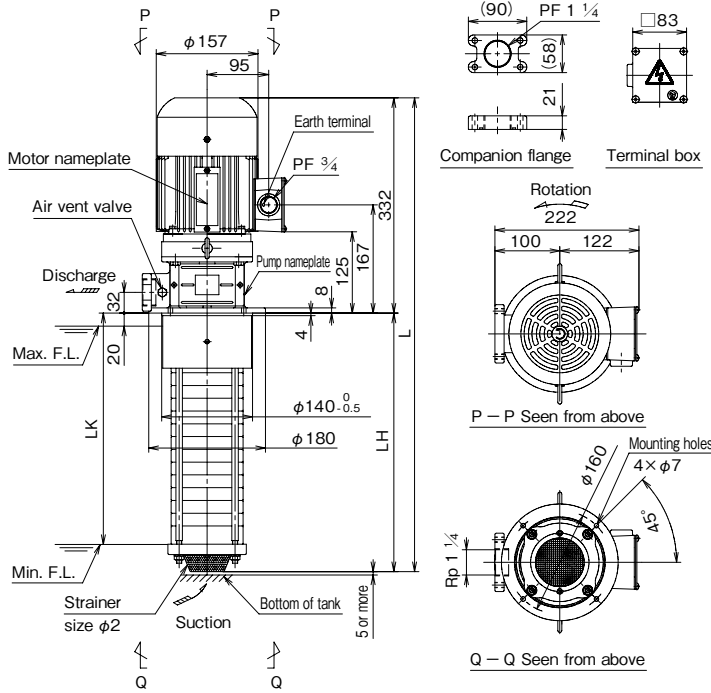
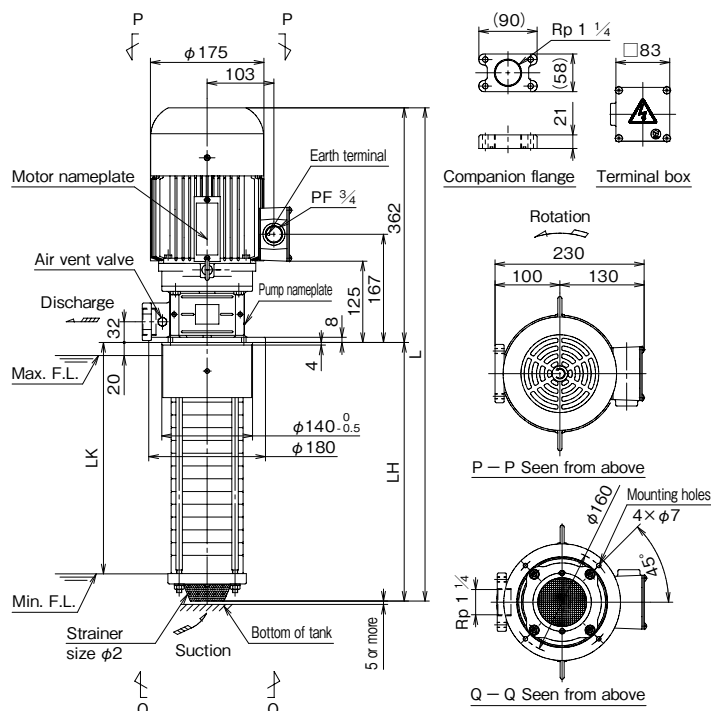

Fig.2



Dimensions

(Unit : mm)

Type	Fig.	L	LH	LK	Approx. mass (kg)
VKB05102AH	1	632	300	258	25
VKB05112AH		652	320	278	25
VKB05132AH		692	360	318	25
VKB05152AH		731	399	357	26
VKB05172AH		770	438	396	26
VKB05182AH		790	458	416	26
VKB06102AH		632	300	258	25
VKB06112AH		652	320	278	25
VKB06132AH		692	360	318	25
VKB06152AH		731	399	357	26
VKB06172AH	770	438	396	26	
VKB06182AH	790	458	416	26	
VKB07102AH	2	632	300	258	25
VKB07112AH		652	320	278	25
VKB07122AH		692	360	318	25
VKB07132AH		731	399	357	26
VKB07152AH		770	438	396	26
VKB07172AH		790	458	416	26
VKB07182AH		790	458	416	26
VKB08102AH		662	300	258	30
VKB08112AH		682	320	278	30
VKB08122AH		722	360	318	30
VKB08132AH	761	399	357	31	
VKB08152AH	800	438	396	31	
VKB08172AH	820	458	416	31	
VKB08182AH	820	458	416	31	
VKB08212AH	879	517	475	32	
VKB08222AH	899	537	495	32	
VKB08262AH	978	616	574	33	
VKB09102AH	662	300	258	30	
VKB09112AH	682	320	278	30	
VKB09122AH	722	360	318	30	
VKB09132AH	761	399	357	31	
VKB09152AH	800	438	396	31	
VKB09172AH	820	458	416	32	
VKB09182AH	820	458	416	32	
VKB09212AH	879	517	475	32	
VKB09222AH	899	537	495	32	
VKB09262AH	978	616	574	33	

\* For China energy label regulation (GB18613-2012) efficiency-compliant unit (grade GB3), contact us for further details.



### Assembly Drawing

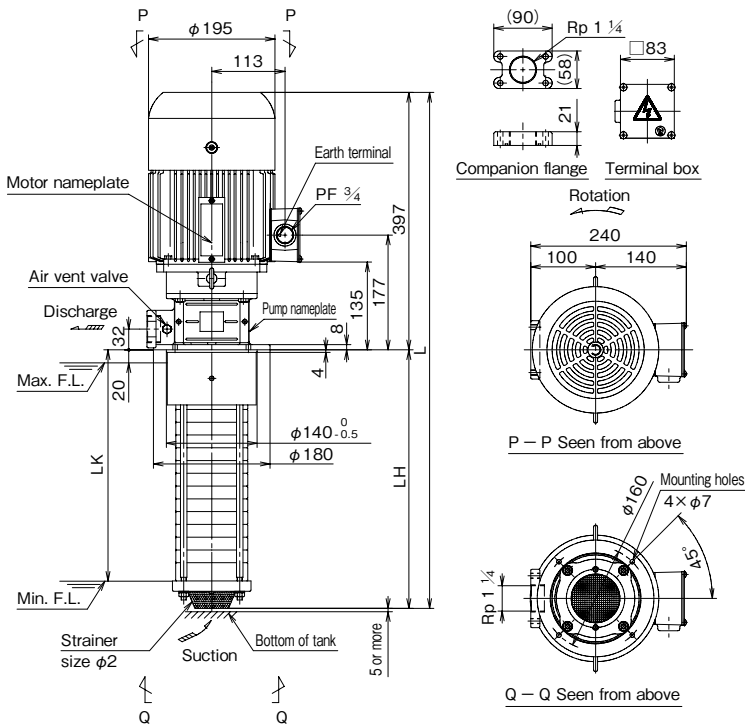

### Dimensions

(Unit : mm)

Type	L	LH	LK	Approx. mass (kg)
VKB10102AH	697	300	258	37
VKB10112AH	717	320	278	37
VKB10132AH	757	360	318	38
VKB10152AH	796	399	357	38
VKB10172AH	835	438	396	39
VKB10182AH	855	458	416	39
VKB10212AH	914	517	475	39
VKB10222AH	934	537	495	40
VKB10262AH	1013	616	574	41
VKB11112AH	717	320	278	37
VKB11132AH	757	360	318	38
VKB11152AH	796	399	357	38
VKB11172AH	835	438	396	39
VKB11182AH	855	458	416	39
VKB11212AH	914	517	475	39
VKB11222AH	934	537	495	40
VKB11262AH	1013	616	574	41
VKB12122AH	737	340	298	38
VKB12132AH	757	360	318	38
VKB12152AH	796	399	357	38
VKB12172AH	835	438	396	39
VKB12182AH	855	458	416	39
VKB12202AH	894	497	455	39
VKB12222AH	934	537	495	40
VKB12262AH	1013	616	574	41
VKB13132AH	757	360	318	38
VKB13152AH	796	399	357	38
VKB13182AH	855	458	416	39
VKB13202AH	894	497	455	39
VKB13222AH	934	537	495	40
VKB13262AH	1013	616	574	41
VKB14142AH	776	379	337	38
VKB14152AH	796	399	357	38
VKB14182AH	855	458	416	39
VKB14192AH	875	478	436	39
VKB14202AH	894	497	455	39
VKB14222AH	934	537	495	40
VKB14262AH	1013	616	574	41
VKB15152AH	796	399	357	38
VKB15182AH	855	458	416	39
VKB15202AH	894	497	455	40
VKB15222AH	934	537	495	40
VKB15262AH	1013	616	574	41
VKB16162AH	816	419	377	39
VKB16182AH	855	458	416	39
VKB16202AH	894	497	455	40
VKB16222AH	934	537	495	40
VKB16262AH	1013	616	574	41
VKB17172AH	835	438	396	39
VKB17182AH	855	458	416	39
VKB17202AH	894	497	455	40
VKB17212AH	914	517	475	40
VKB17222AH	934	537	495	40
VKB17262AH	1013	616	574	41
VKB18182AH	855	458	416	39
VKB18202AH	894	497	455	40
VKB18212AH	914	517	475	40
VKB18222AH	934	537	495	40
VKB18242AH	973	576	534	41
VKB18252AH	993	596	554	41
VKB18262AH	1013	616	574	41
VKB19212AH	914	517	475	40
VKB19262AH	1013	616	574	41

\* For China energy label regulation (GB18613-2012) efficiency-compliant unit (grade GB3), contact us for further details.

Assembly Drawing

Fig.1

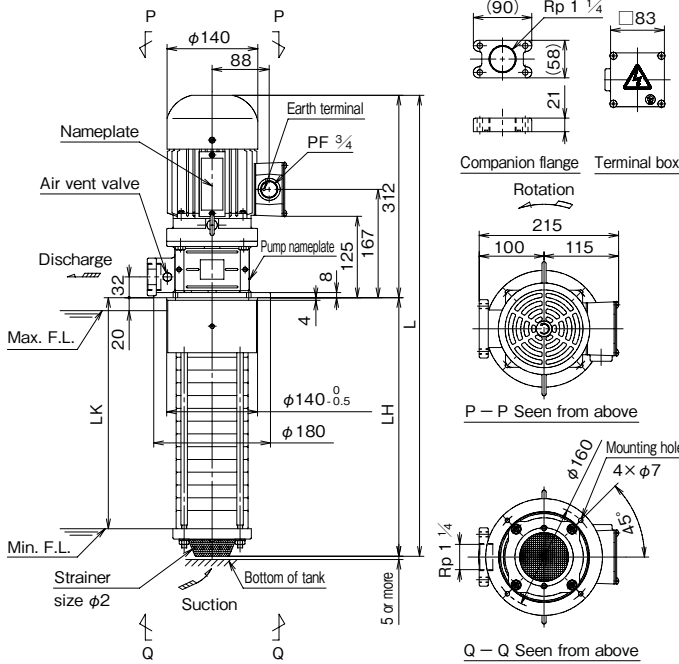
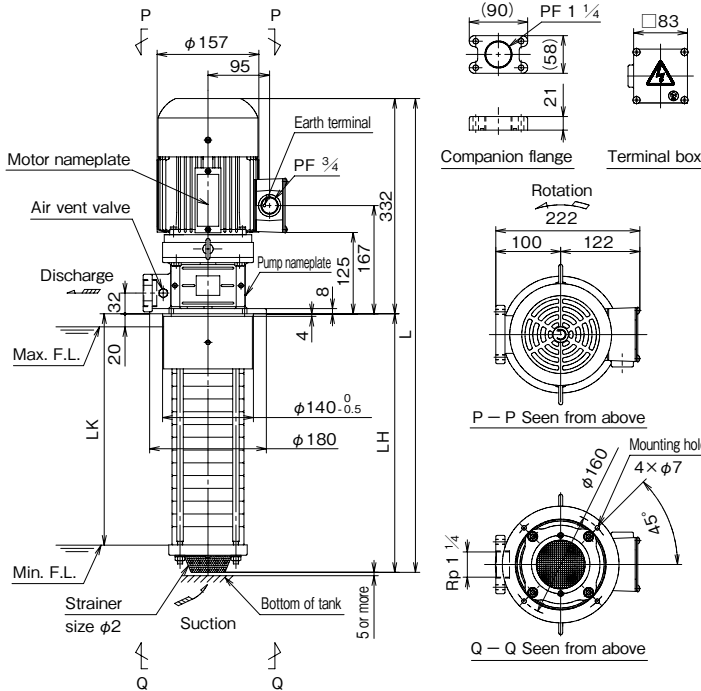

Fig.2



Dimensions

●[50Hz Exclusive]

(Unit : mm)

Type	Fig.	L	LH	LK	Approx. mass (kg)	
VKB05102FH	1	612	300	258	21	
VKB05112FH		632	320	278	20	
VKB05132FH		672	360	318	21	
VKB05152FH		711	399	357	21	
VKB05182FH		770	458	416	22	
VKB06102FH		612	300	258	21	
VKB06112FH		632	320	278	21	
VKB06132FH		672	360	318	21	
VKB06152FH		711	399	357	21	
VKB06182FH		770	458	416	22	
VKB07102FH		612	300	258	21	
VKB07112FH		632	320	278	21	
VKB07132FH		672	360	318	21	
VKB07152FH		711	399	357	22	
VKB07172FH		750	438	396	22	
VKB07182FH		770	458	416	22	
VKB07222FH		849	537	495	23	
VKB07262FH		928	616	574	24	
VKB08102FH		2	632	300	258	25
VKB08112FH			652	320	278	25
VKB08132FH	692		360	318	25	
VKB08152FH	731		399	357	26	
VKB08172FH	770		438	396	26	
VKB08182FH	790		458	416	27	
VKB08212FH	849		517	475	27	
VKB08222FH	869		537	495	27	
VKB08262FH	948		616	574	28	
VKB09102FH	632		300	258	25	
VKB09112FH	652		320	278	25	
VKB09132FH	692		360	318	26	
VKB09152FH	731		399	357	26	
VKB09172FH	770		438	396	26	
VKB09182FH	790		458	416	27	
VKB09212FH	849		517	475	27	
VKB09222FH	869		537	495	28	
VKB09262FH	948		616	574	28	
VKB10102FH	632		300	258	25	
VKB10112FH	652		320	278	25	
VKB10132FH	692	360	318	26		
VKB10152FH	731	399	357	26		
VKB10172FH	770	438	396	26		
VKB10182FH	790	458	416	27		
VKB10212FH	849	517	475	27		
VKB10222FH	869	537	495	28		
VKB10262FH	948	616	574	28		

\* For China energy label regulation (GB18613-2012) efficiency-compliant unit (grade GB3), contact us for further details.

### Assembly Drawing

Fig.3

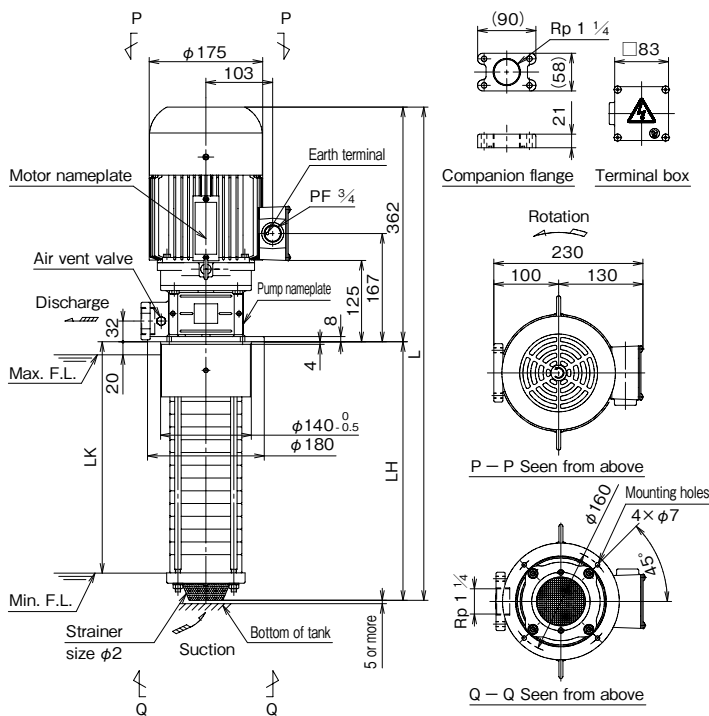
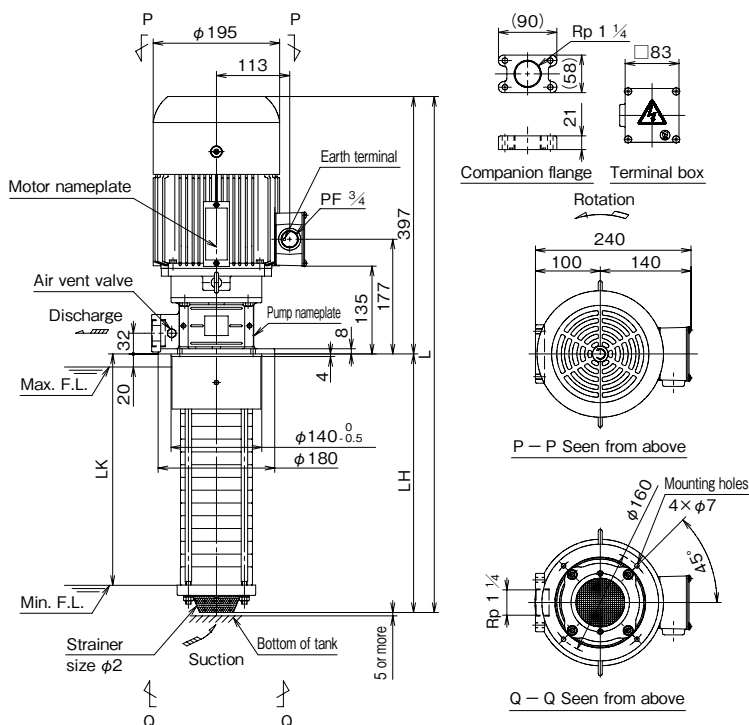

Fig.4



### Dimensions

●[50Hz Exclusive]

(Unit: mm)

Type	Fig.	L	LH	LK	Approx. mass (kg)
VKB11112FH	3	682	320	278	30
VKB11132FH		722	360	318	31
VKB11152FH		761	399	357	31
VKB11172FH		800	438	396	31
VKB11182FH		820	458	416	32
VKB11212FH		879	517	475	32
VKB11222FH		899	537	495	33
VKB11262FH		978	616	574	33
VKB12122FH		702	340	298	30
VKB12132FH		722	360	318	31
VKB12152FH		761	399	357	31
VKB12172FH		800	438	396	32
VKB12182FH		820	458	416	32
VKB12212FH		859	497	455	32
VKB12222FH		899	537	495	33
VKB12262FH		978	616	574	34
VKB13132FH		722	360	318	31
VKB13152FH		761	399	357	31
VKB13172FH		800	438	396	32
VKB13182FH		820	458	416	32
VKB13212FH		859	497	455	32
VKB13222FH		899	537	495	33
VKB13262FH		978	616	574	34
VKB14142FH		741	379	337	31
VKB14152FH		761	399	357	31
VKB14182FH		820	458	416	32
VKB14212FH		859	497	455	33
VKB14222FH		899	537	495	33
VKB14262FH		978	616	574	34
VKB15152FH		761	399	357	31
VKB15162FH		781	419	377	32
VKB15172FH		800	438	396	32
VKB15182FH	820	458	416	32	
VKB15212FH	859	497	455	33	
VKB15222FH	899	537	495	33	
VKB15262FH	978	616	574	34	
VKB16162FH	781	419	377	32	
VKB16172FH	800	438	396	32	
VKB16182FH	820	458	416	32	
VKB16212FH	859	497	455	33	
VKB16222FH	899	537	495	33	
VKB16262FH	978	616	574	34	
VKB17172FH	800	438	396	32	
VKB17182FH	820	458	416	32	
VKB17212FH	879	517	475	33	
VKB17222FH	899	537	495	33	
VKB17262FH	978	616	574	34	
VKB18182FH	820	458	416	32	
VKB18212FH	879	517	475	33	
VKB18222FH	899	537	495	33	
VKB18232FH	938	576	534	33	
VKB18262FH	978	616	574	34	
VKB19192FH	840	478	436	33	
VKB19212FH	879	517	475	33	
VKB19222FH	899	537	495	33	
VKB19262FH	978	616	574	34	
VKB20202FH	894	497	455	40	
VKB20212FH	914	517	475	40	
VKB20222FH	934	537	495	40	
VKB20262FH	1013	616	574	41	
VKB21212FH	914	517	475	40	
VKB21222FH	934	537	495	41	
VKB21262FH	1013	616	574	41	
VKB22222FH	934	537	495	41	
VKB22242FH	973	576	534	41	
VKB22262FH	1013	616	574	41	
VKB23232FH	953	556	514	41	
VKB23262FH	1013	616	574	42	
VKB24242FH	973	576	534	41	
VKB24262FH	1013	616	574	42	
VKB25252FH	993	596	554	41	
VKB25262FH	1013	616	574	42	
VKB26262FH	1013	616	574	42	

\* For China energy label regulation (GB18613-2012) efficiency-compliant unit (grade GB3), contact us for further details.

## Sectional drawing

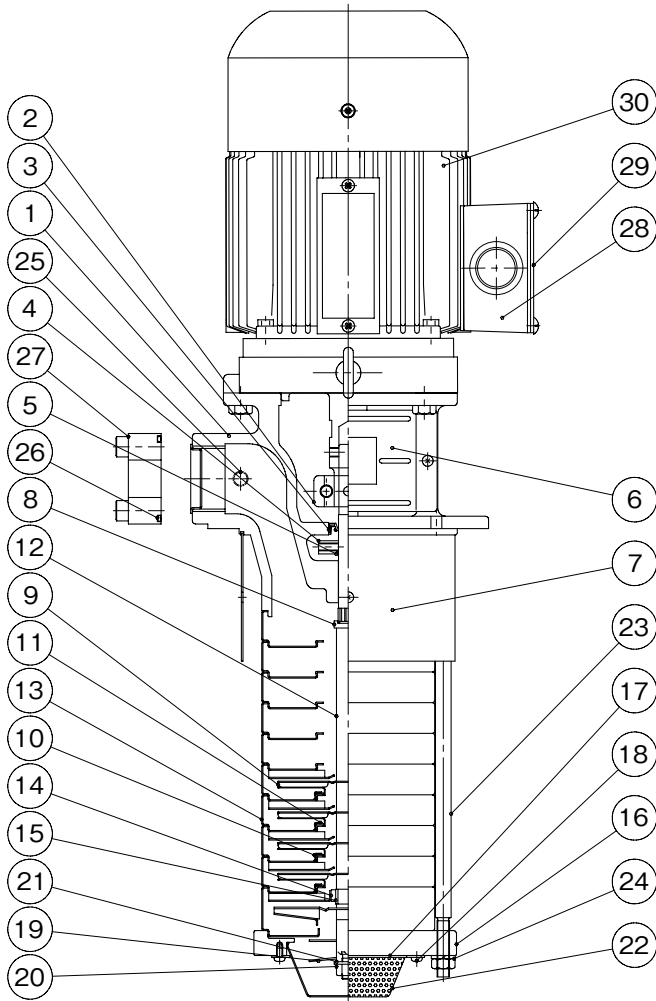

No.	Parts Name	Materials
1	Pump leg	FC200
2	Coupling	S45C
3	Oil seal	NBR
4	Oil thrower	SUS304
5	O-ring	FKM
6	Coupling guard	SUS304
7	Outer casing	SUS304
8	Washer	SUS403
9	Impeller	SUS304
10	Seal ring	PTFE
11	Clamp	SUS304
12	Collar	SUS304
13	Casing	SUS304
14	Bearing ring	CERAMIC
15	Sleeve	WC
16	Suction chamber	FC200
17	Strainer retainer plate	SUS304
18	Cross-recessed pan head machine screw	SUS304
19	Screw	SUS304
20	U-nut	SUS304
21	Washer	SUS304
22	Wide strainer	SUS304
23	Fastening bolt	SUS304
24	Washer	SUS304
25	Air vent valve	BLASS
26	O-ring	FKM
27	Companion flange	FC150
28	Terminal box	ADC
29	Terminal box cover	SS400
30	Motor	

Note: Structure and other details are subject to change without notice.

#### Features

- ① Mechanical seal-less structure
- ② EU RoHS Directive (Restriction of Use of Six Hazardous Substances) compliant
- ③ European Standards (EN) compliant
  - EU Directives for CE marking
  - IEC-compatible terminal box
- ④ China energy label regulation (GB18613-2012) efficiency-compliant unit (grade GB3) available
- ⑤ Impellers designed for high-frequency operation
- ⑥ Enhanced protection against mist and other environmental elements
  - IP54 protection
  - Oil seals in the motor
- ⑦ Energy-saving operation by the inverter (flow rate adjusting, etc.) (10 to 60Hz)

Note: Resonance may occur arbitrarily when the unit is operated at variable speeds using the inverter. Operate the unit avoiding the resonance points.

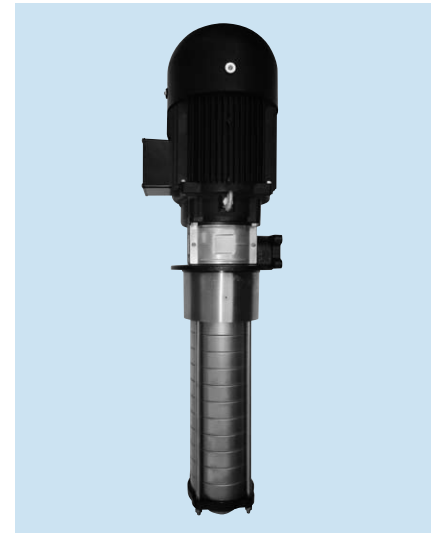

#### Structure

Non-seal (mechanical seal-less) structure. Aluminum frame is used in the motor section and stainless steel is used in the pump's main unit. Special coupling is used for the connection.

#### How to read the model type

**VKB 04 07 2 A Q**

①    ②    ③    ④    ⑤    ⑥    ⑦

- ① Model
- ② Number of impellers
- ③ Number of stages
- ④ Series
- ⑤ Number of phases · Frequency (A: 3 phases, 50/60Hz; F: 3 phases, 50Hz exclusive)
- ⑥ Characteristics (Q: standard type)
- ⑦ Efficiency regulation-compliant (No mark: standard)
  - G: China energy label regulation (GB18613-2012) efficiency-compliant unit (grade GB3) (200V, 50Hz)
  - GS: China energy label regulation (GB18613-2012) efficiency-compliant unit (grade GB3) (380V, 50Hz)

#### Selection chart (performance drawings)

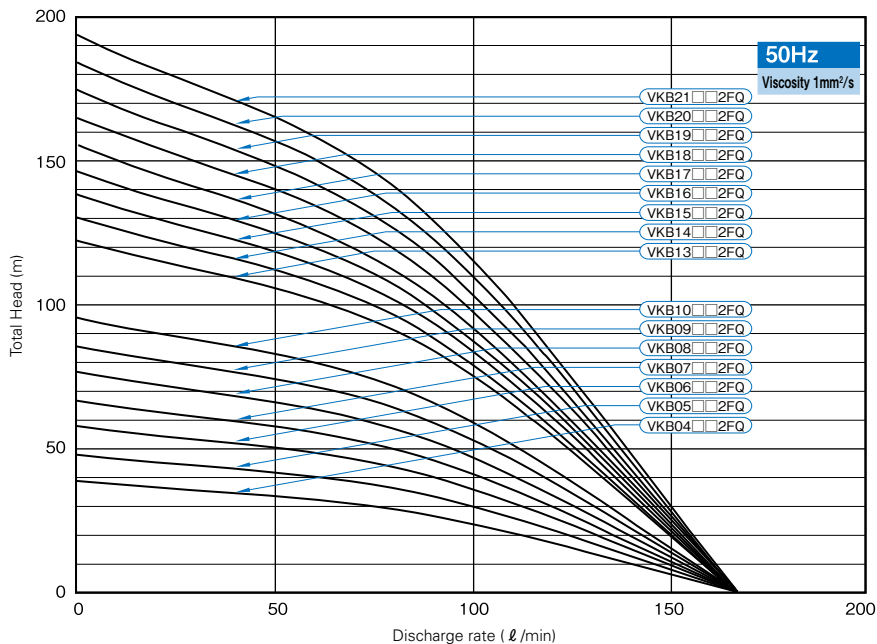

Note: The above characteristic curves reflect the full impeller condition of the units. The total head may be decreased depending on the flow rate if empty casings are involved because of pressure loss at the empty casings.

**Selection chart**  
(performance drawings)

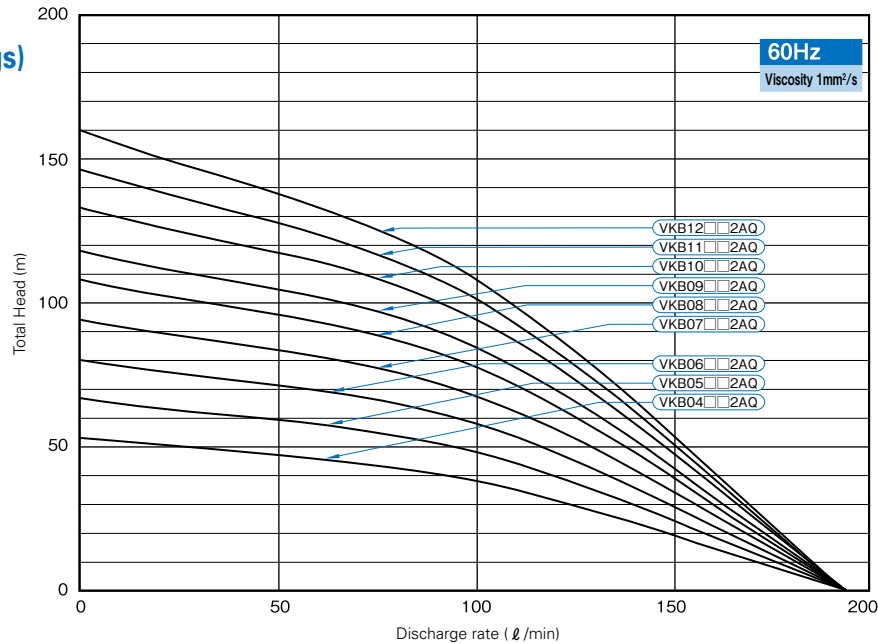

Notes 1.The above characteristic curves reflect the full impeller condition of the units. The total head may be decreased depending on the flow rate if empty casings are involved because of pressure loss at the empty casings.  
2.The performance significantly varies according to the type of liquid circulated and the liquid's viscosity. Depending on the viscosity or specific weight, some types of liquid cannot be used.

**Specifications**

Specifications	Type	VKB04□□2AQ	VKB05□□2AQ	VKB06□□2AQ	VKB07□□2AQ	VKB08□□2AQ	VKB09□□2AQ	VKB10□□2AQ	VKB11□□2AQ	VKB12□□2AQ										
Nominal output	(W)	0.72	1.2	0.9	1.5	1.08	1.8	1.26	2.1	1.44	2.4	1.62	2.7	1.8	3.0	1.98	3.3	2.16	3.6	
Rated voltage	(V)	200	200	200	200	200	200	200	200	200	200	200	200	200	200	200	200	200	200	200
Frequency	(Hz)	50	60	50	60	50	60	50	60	50	60	50	60	50	60	50	60	50	60	50
Rated current	(A)	6.0	7.1	6.8	8.9	7.8	11.0	10.9	11.3	11.6	12.7	12.4	14.0	13.2	15.5	14.1	17.0	15.1	18.0	16.8
Discharge rate	(l/min)	85	100	85	100	85	100	85	100	85	100	85	100	85	100	85	100	85	100	85
Total head	(m)	26	36	33	46	39	54	45	63	52	72	58	81	65	90	71	99	78	108	88
Max. viscosity allowed	(mm²/s)	75	37.5	75	75	75	37.5	75	75	75	75	75	75	75	75	75	75	75	75	37.5
Outlet	(Rp)	1¼																		
Paint color		Munsell N1																		
Standard		IEC60034-1 CE approved																		
Degree of protection		IP54																		

**●[50Hz Exclusive]**

Specifications	Type	VKB04□□2FQ	VKB05□□2FQ	VKB06□□2FQ	VKB07□□2FQ	VKB08□□2FQ	VKB09□□2FQ	VKB10□□2FQ	VKB13□□2FQ	
Nominal output	(W)	0.72	0.9	1.08	1.26	1.44	1.62	1.8	2.34	
Rated voltage	(V)	200	200	200	200	200	200	200	200	
Rated current	(A)	4.4	6.0	6.9	6.8	7.6	8.4	9.2	12.5	
Discharge rate	(l/min)	85	85	85	85	85	85	85	85	
Total head	(m)	26	33	39	45	52	58	65	84	
Max. viscosity allowed	(mm²/s)	1	1	1	1	1	1	1	1	
Outlet	(Rp)	1¼								
Paint color		Munsell N1								
Standard		IEC60034-1 CE approved								
Degree of protection		IP54								

Specifications	Type	VKB14□□2FQ	VKB15□□2FQ	VKB16□□2FQ	VKB17□□2FQ	VKB18□□2FQ	VKB19□□2FQ	VKB20□□2FQ	VKB21□□2FQ	
Nominal output	(W)	2.52	2.7	2.88	3.06	3.24	3.42	3.6	3.78	
Rated voltage	(V)	200	200	200	200	200	200	200	200	
Rated current	(A)	13.1	13.7	14.4	15.1	15.8	16.5	17.3	18.1	
Discharge rate	(l/min)	85	85	85	85	85	85	85	85	
Total head	(m)	91	97	104	110	117	123	130	136	
Max. viscosity allowed	(mm²/s)	1	1	1	1	1	1	1	1	
Outlet	(Rp)	1¼								
Paint color		Munsell N1								
Standard		IEC60034-1 CE approved								
Degree of protection		IP54								

Notes 1. The 50Hz exclusive units are for use with water-soluble liquids (1mm²/s kinematic viscosity) only. Contact us when your applications involve oil-based liquids.  
2. Contact us when your applications involve special liquids(demineralized water, alkali/acidic liquids, etc.).  
3. Liquid temperature range -20 to +90°C (without freezing).

\* For China energy label regulation (GB18613-2012) efficiency-compliant unit (grade GB3), contact us for further details.

**Special specifications**

Motor modifications	Change in voltage, change in position of terminal box, change in direction of terminal box
Change in structure	Stainless-steel suction chamber*

\*Models are subject to change. "-SU" is added as a suffix.

Note: The suction chamber is not 100% made of stainless steel. Pump legs and companion flanges are made of cast iron.

### Assembly Drawing

**Fig.1**

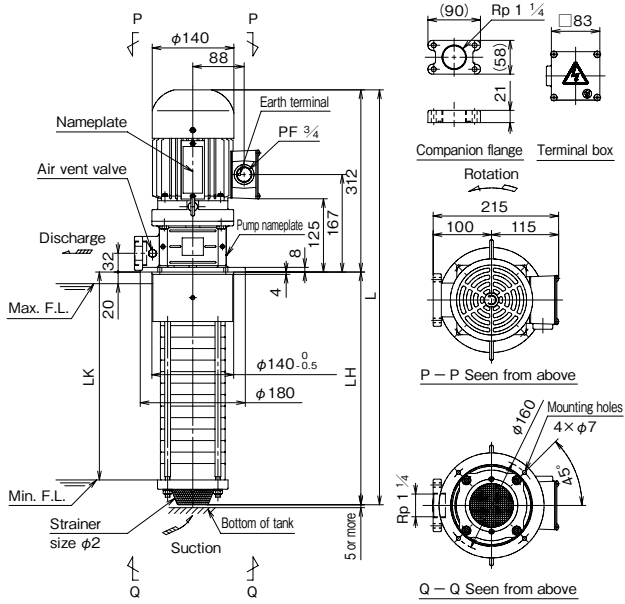

**Fig.2**

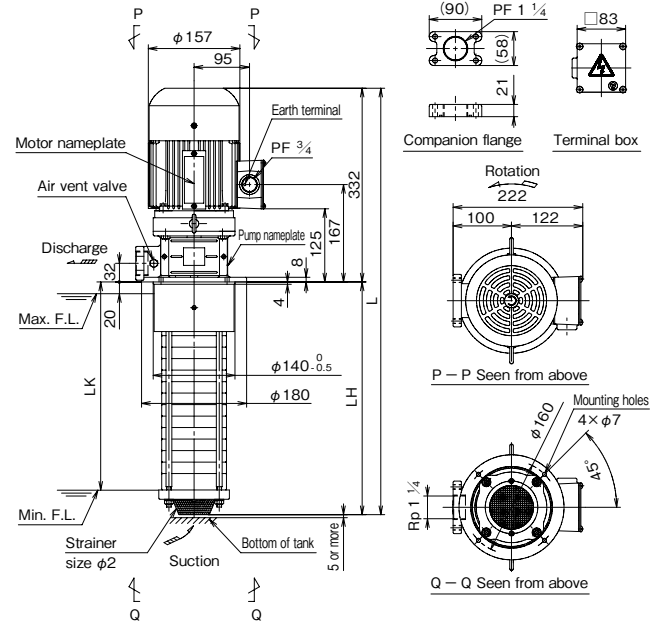

**Fig.3**

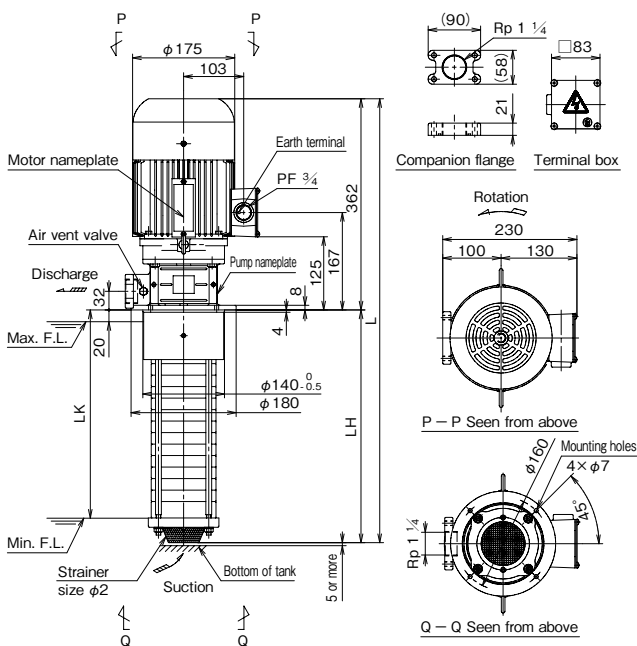

**Fig.4**

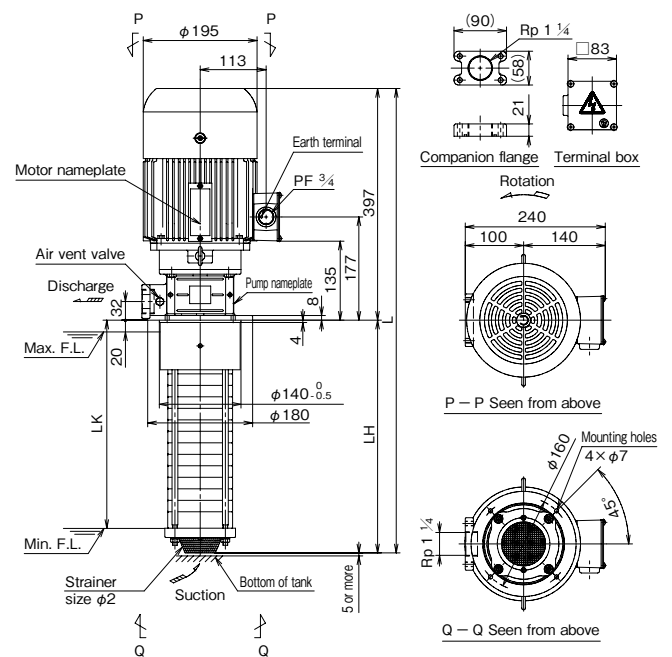



## Dimensions

Type	Fig.	(Unit : mm)				Approx. mass (kg)
		L	LH	LK		
VKB04072AQ	2	623	291	249	24	
VKB04082AQ		651	319	277	24	
VKB04092AQ		679	347	305	24	
VKB04102AQ		707	375	333	25	
VKB04122AQ		763	431	389	25	
VKB04142AQ		819	487	445	26	
VKB04152AQ		847	515	473	26	
VKB04162AQ		875	543	501	26	
VKB04192AQ		959	627	585	27	
VKB04222AQ		1043	711	669	28	
VKB05072AQ		3	653	291	249	29
VKB05082AQ			681	319	277	29
VKB05092AQ	709		347	305	29	
VKB05102AQ	737		375	333	30	
VKB05122AQ	793		431	389	30	
VKB05142AQ	849		487	445	31	
VKB05152AQ	877		515	473	31	
VKB05162AQ	905		543	501	31	
VKB05192AQ	989		627	585	32	
VKB05222AQ	1073		711	669	33	
VKB06072AQ	4		653	291	249	29
VKB06082AQ			681	319	277	29
VKB06092AQ		709	347	305	30	
VKB06102AQ		737	375	333	30	
VKB06122AQ		793	431	389	30	
VKB06142AQ		849	487	445	31	
VKB06152AQ		877	515	473	31	
VKB06162AQ		905	543	501	31	
VKB06192AQ		989	627	585	32	
VKB06222AQ		1073	711	669	33	
VKB07072AQ		4	688	291	249	36
VKB07082AQ			716	319	277	37
VKB07092AQ	744		347	305	37	
VKB07102AQ	772		375	333	37	
VKB07122AQ	828		431	389	37	
VKB07142AQ	884		487	445	38	
VKB07152AQ	912		515	473	38	
VKB07162AQ	940		543	501	38	
VKB07192AQ	1024		627	585	39	

Type	Fig.	(Unit : mm)				Approx. mass (kg)
		L	LH	LK		
VKB07222AQ	4	1108	711	669	40	
VKB08082AQ		716	319	277	37	
VKB08092AQ		744	347	305	37	
VKB08102AQ		772	375	333	37	
VKB08122AQ		828	431	389	38	
VKB08142AQ		884	487	445	38	
VKB08152AQ		912	515	473	38	
VKB08162AQ		940	543	501	39	
VKB08192AQ		1024	627	585	39	
VKB08222AQ		1108	711	669	40	
VKB09092AQ		744	347	305	37	
VKB09102AQ		772	375	333	37	
VKB09122AQ	828	431	389	38		
VKB09142AQ	884	487	445	38		
VKB09152AQ	912	515	473	38		
VKB09162AQ	940	543	501	39		
VKB09192AQ	1024	627	585	39		
VKB09222AQ	1108	711	669	40		
VKB10102AQ	772	375	333	37		
VKB10122AQ	828	431	389	38		
VKB10142AQ	884	487	445	38		
VKB10152AQ	912	515	473	39		
VKB10162AQ	940	543	501	39		
VKB10192AQ	1024	627	585	39		
VKB10222AQ	1108	711	669	40		
VKB11112AQ	800	403	361	38		
VKB11122AQ	828	431	389	38		
VKB11142AQ	884	487	445	38		
VKB11152AQ	912	515	473	39		
VKB11162AQ	940	543	501	39		
VKB11192AQ	1024	627	585	40		
VKB11222AQ	1108	711	669	40		
VKB12122AQ	828	431	389	38		
VKB12142AQ	884	487	445	38		
VKB12152AQ	912	515	473	39		
VKB12162AQ	940	543	501	39		
VKB12192AQ	1024	627	585	40		
VKB12222AQ	1108	711	669	40		

Notes: Contact us if you cannot find a suitable unit in the above model menu.

\* For China energy label regulation (GB18613-2012) efficiency-compliant unit (grade GB3), contact us for further details.



### Dimensions

● [50Hz Exclusive]

(Unit : mm)

Type	Fig.	L	LH	LK	Approx. mass (kg)	
VKB04072FQ	1	603	291	249	20	
VKB04082FQ		631	319	277	20	
VKB04102FQ		687	375	333	20	
VKB04122FQ		743	431	389	21	
VKB04142FQ		799	487	445	21	
VKB04162FQ		855	543	501	22	
VKB04192FQ		939	627	585	23	
VKB04222FQ		1023	711	669	23	
VKB05072FQ		2	623	291	249	24
VKB05082FQ			651	319	277	24
VKB05102FQ	707		375	333	25	
VKB05122FQ	763		431	389	25	
VKB05142FQ	819		487	445	26	
VKB05162FQ	875		543	501	26	
VKB05192FQ	959		627	585	27	
VKB05222FQ	1043		711	669	28	
VKB06072FQ	3		623	291	249	24
VKB06082FQ			651	319	277	24
VKB06102FQ		707	375	333	25	
VKB06122FQ		763	431	389	25	
VKB06142FQ		819	487	445	26	
VKB06162FQ		875	543	501	26	
VKB06192FQ		959	627	585	27	
VKB06222FQ		1043	711	669	28	
VKB07072FQ		4	653	291	249	29
VKB07082FQ			681	319	277	29
VKB07102FQ	737		375	333	30	
VKB07122FQ	793		431	389	30	
VKB07142FQ	849		487	445	31	
VKB07162FQ	905		543	501	31	
VKB07192FQ	989		627	585	32	
VKB07222FQ	1073		711	669	33	
VKB08082FQ	5		681	319	277	30
VKB08102FQ			737	375	333	30
VKB08122FQ		793	431	389	30	
VKB08142FQ		849	487	445	31	
VKB08162FQ		905	543	501	31	
VKB08192FQ		989	627	585	32	
VKB08222FQ		1073	711	669	33	
VKB09092FQ		6	709	347	305	30
VKB09102FQ			737	375	333	30

(Unit : mm)

Type	Fig.	L	LH	LK	Approx. mass (kg)	
VKB09122FQ	3	793	431	389	31	
VKB09142FQ		849	487	445	31	
VKB09162FQ		905	543	501	32	
VKB09192FQ		989	627	585	32	
VKB09222FQ		1073	711	669	33	
VKB10102FQ		4	737	375	333	30
VKB10122FQ			793	431	389	31
VKB10142FQ			849	487	445	31
VKB10162FQ			989	627	585	32
VKB10192FQ			1017	655	613	32
VKB10222FQ	1073		711	669	33	
VKB13132FQ	5		856	459	417	38
VKB13142FQ			884	487	445	39
VKB13162FQ			940	543	501	39
VKB13192FQ			1024	627	585	40
VKB13202FQ		1052	655	613	40	
VKB13222FQ		1108	711	669	41	
VKB14142FQ		6	884	487	445	39
VKB14162FQ			940	543	501	39
VKB14192FQ			1024	627	585	40
VKB14222FQ			1108	711	669	41
VKB15152FQ	912		515	473	39	
VKB15162FQ	940		543	501	39	
VKB15192FQ	1024		627	585	40	
VKB15222FQ	1108		711	669	41	
VKB16162FQ	7		940	543	501	39
VKB16192FQ			1024	627	585	40
VKB16222FQ		1108	711	669	41	
VKB17172FQ		968	571	529	40	
VKB17192FQ		1024	627	585	40	
VKB17222FQ		1108	711	669	41	
VKB18182FQ		8	996	599	557	40
VKB18192FQ			1024	627	585	40
VKB18222FQ			1108	711	669	41
VKB19192FQ			1024	627	585	40
VKB19222FQ	1108		711	669	41	
VKB20202FQ	1052		655	613	41	
VKB20222FQ	1108		711	669	41	
VKB21212FQ	9		1080	683	641	41
VKB21222FQ			1108	711	669	41

Notes: Contact us if you cannot find a suitable unit in the above model menu.

\* For China energy label regulation (GB18613-2012) efficiency-compliant unit (grade GB3), contact us for further details.

Sectional drawing

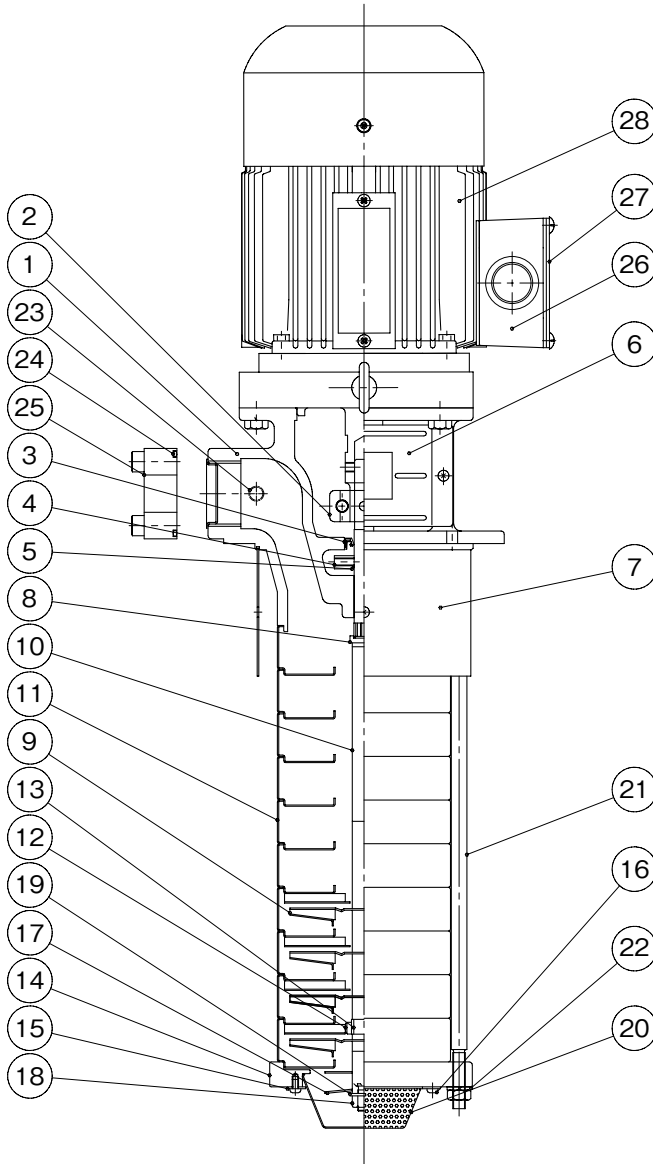

No.	Parts Name	Materials
1	Pump leg	FC200
2	Coupling	S45C
3	Oil seal	NBR
4	Oil thrower	SUS304
5	O-ring	FKM
6	Coupling guard	SUS304
7	Outer casing	SUS304
8	Washer	SUS403
9	Impeller	SUS304
10	Collar	SUS304
11	Casing	SUS304
12	Bearing ring	CERAMIC
13	Sleeve	WC
14	Suction chamber	FC200
15	Strainer retainer plate	SUS304
16	Cross-recessed pan head machine screw	SUS304
17	Screw	SUS304
18	U-nut	SUS304
19	Washer	SUS304
20	Wide strainer	SUS304
21	Fastening bolt	SUS304
22	Washer	SUS304
23	Air vent valve	BLASS
24	O-ring	FKM
25	Companion flange	FC150
26	Terminal box	ADC
27	Terminal box cover	SS400
28	Motor	

Note: Structure and other details are subject to change without notice.

#### Features

- ① The motor and the pump are integrated for smaller sizes and lighter weights
- ② With the self-priming function, the unit can be easily installed in confined areas
- ③ EU RoHS Directive (Restriction of Use of Six Hazardous Substances) compliant
- ④ Meets the EU Directive for CE marking
- ⑤ China energy label regulation (GB18613-2012) efficiency-compliant unit (grade GB3) available
- ⑥ Enhanced protection against mist and other environmental elements



#### Structure

Mechanical seal structure. The motor section and pump section are integrated and cast iron is used in the pump's main unit.

#### How to read the model type

**VKN 07 5 A**

①      ②      ③      ④      ⑤

- ① Model
- ② Output code(ex. 06: 100W)
- ③ Series
- ④ Number of phases and characteristics
- ⑤ Compliance with voltage/energy efficiency regulation (no description: standard; 4Z: different voltage  
-G: China energy label regulation (GB18613-2012) efficiency-compliant unit (grade GB3) (200V, 50Hz)  
-GS: China energy label regulation (GB18613-2012) efficiency-compliant unit (grade GB3) (220/380V, 50Hz)

#### Selection chart (performance drawings)

**VKN045A(L)/045A-4Z**

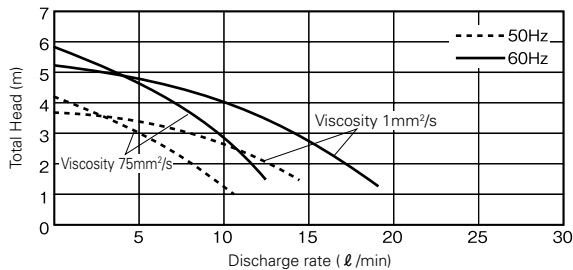

**VKN055A/055A-4Z**

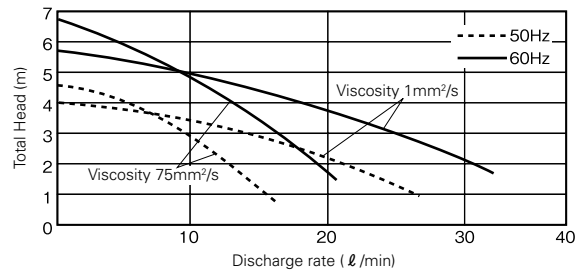

**VKN065A/065A-4Z**

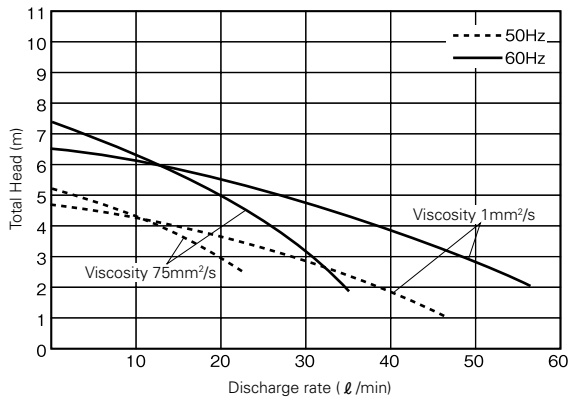

**VKN075A/075A-4Z**

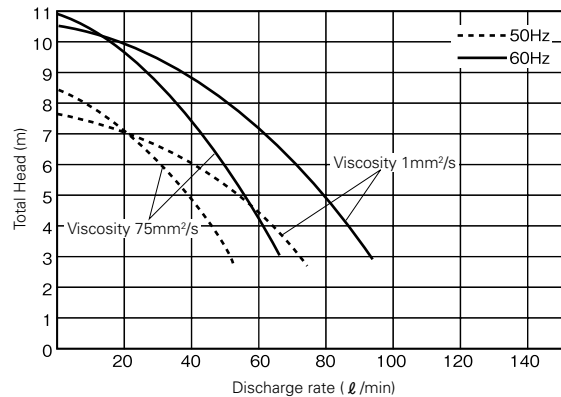

**VKN085A/085A-4Z**

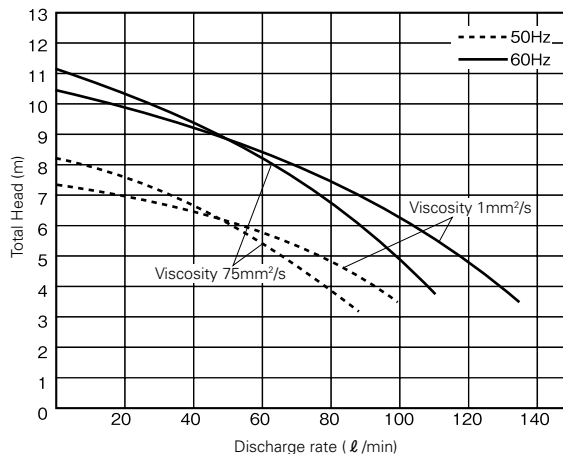

**VKN095A/095A-4Z**

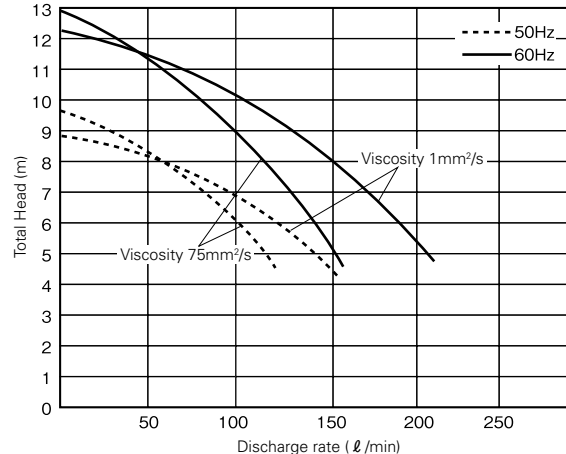

Note: The discharge rate will vary significantly depending on the type of liquid circulated and the liquid's viscosity.

## Selection chart (performance drawings)

### VKN115A/115A-4Z/115A-G/115A-GS

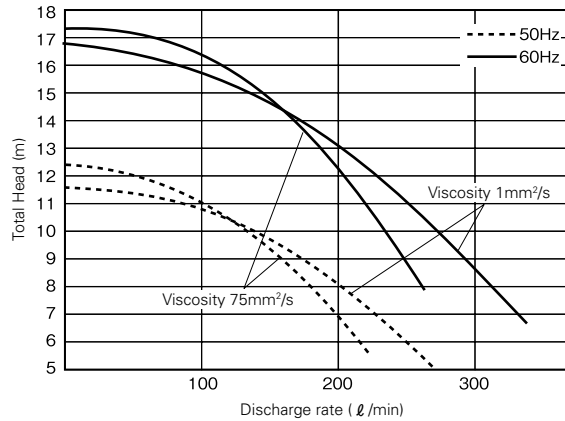

Note: The discharge rate will vary significantly depending on the type of liquid circulated and the liquid's viscosity.

## Specifications

### Standard voltage

Specifications	Type	VKN045A(L)*		VKN055A		VKN065A		VKN075A		VKN085A		VKN095A		VKN115A	
Nominal output	(W)	40		60		100		180		250		400		750	
Rated voltage	(V)	200	200 220	200	200 220	200	200 220	200	200 220	200	200 220	200	200 220	200	200 220
Frequency	(Hz)	50	60	50	60	50	60	50	60	50	60	50	60	50	60
Rated current	(A)	0.32	0.31 0.31	0.4	0.35 0.35	0.55	0.5	0.85	1.0 1.0	1.2	1.5 1.5	2.4	2.5 2.4	3.3	4.5 4.2
Discharge rate	(l/min)	13	16	16	24	39	50	50	67	95	130	140	200	230	320
Total head	(m)	1.5		2		2		3		4		5		7	
Max. length of suction pipe	(m)	0.7		0.7		0.7		0.7		0.6		0.7		0.7	
Max. viscosity allowed	(mm²/s)	200	75	200	75	200	75	200	75	200	75	200	75	200	75
Inlet/outlet	(Rp)	1/4		3/8		3/8		1/2		3/4		1		1½	
Paint color		Munsell N1													
Standard		IEC60034-1 CE approved													
Degree of protection		IP54													

### Different voltage

Specifications	Type	VKN045A-4Z		VKN055A-4Z		VKN065A-4Z		VKN075A-4Z		VKN085A-4Z		VKN095A-4Z		VKN115A-4Z	
Nominal output	(W)	40		60		100		180		250		400		750	
Rated voltage	(V)	380 400 415	400 440	380 400 415	400 440	380 400 415	400 440	380 400 415	400 440	380 400 415	400 440	380 400 415	400 440	380 400 415	400 440
Frequency	(Hz)	50	60	50	60	50	60	50	60	50	60	50	60	50	60
Rated current	(A)	0.16 0.16 0.17	0.16 0.16	0.19 0.20 0.22	0.18 0.18	0.28 0.28 0.29	0.25 0.25	0.44 0.43 0.42	0.5 0.5	0.65 0.6 0.6	0.75 0.75	1.2 1.2 1.2	1.3 1.2	1.7 1.7 1.7	2.3 2.1
Discharge rate	(l/min)	13	16	16	24	39	50	50	67	95	130	140	200	230	320
Total head	(m)	1.5		2		2		3		4		5		7	
Max. length of suction pipe	(m)	0.7		0.7		0.7		0.7		0.6		0.7		0.7	
Max. viscosity allowed	(mm²/s)	200	75	200	75	200	75	200	75	200	75	200	75	200	75
Inlet/outlet	(Rp)	1/4		3/8		3/8		1/2		3/4		1		1½	
Paint color		Munsell N1													
Standard		IEC60034-1 CE approved													
Degree of protection		IP54													

### China energy label regulation (GB18613-2012) efficiency-compliant unit (grade GB3)

Specifications	Type	VKN115A-G	VKN115A-GS
Nominal output	(W)	750	750
Rated voltage	(V)	200	220 380
Frequency	(Hz)	50	
Rated current	(A)	3.3	3.1 1.8
Discharge rate	(l/min)	230	
Total head	(m)	7	
Max. length of suction pipe	(m)	0.7	
Max. viscosity allowed	(mm²/s)	200	
Inlet/outlet	(Rp)	1½	
Paint color		Munsell N1	
Standard		IEC60034-1 CE approved	
Degree of protection		IP44	

- Notes
1. As the pump whose model number has a suffix L (with marked ★) has cable leads, it does not conform to CE marking and its degree of protection is IP23.
  2. The discharge rate and total head values were obtained in tests with a liquid viscosity of 1mm²/s (same as tap water at normal temperature). Note that the pumps cannot be used with water.
  3. If the pipe diameter (inlet and outlet) is different from the standard diameter, the maximum length of suction pipe is inversely proportional to the square of the pipe diameter.

### Assembly Drawing

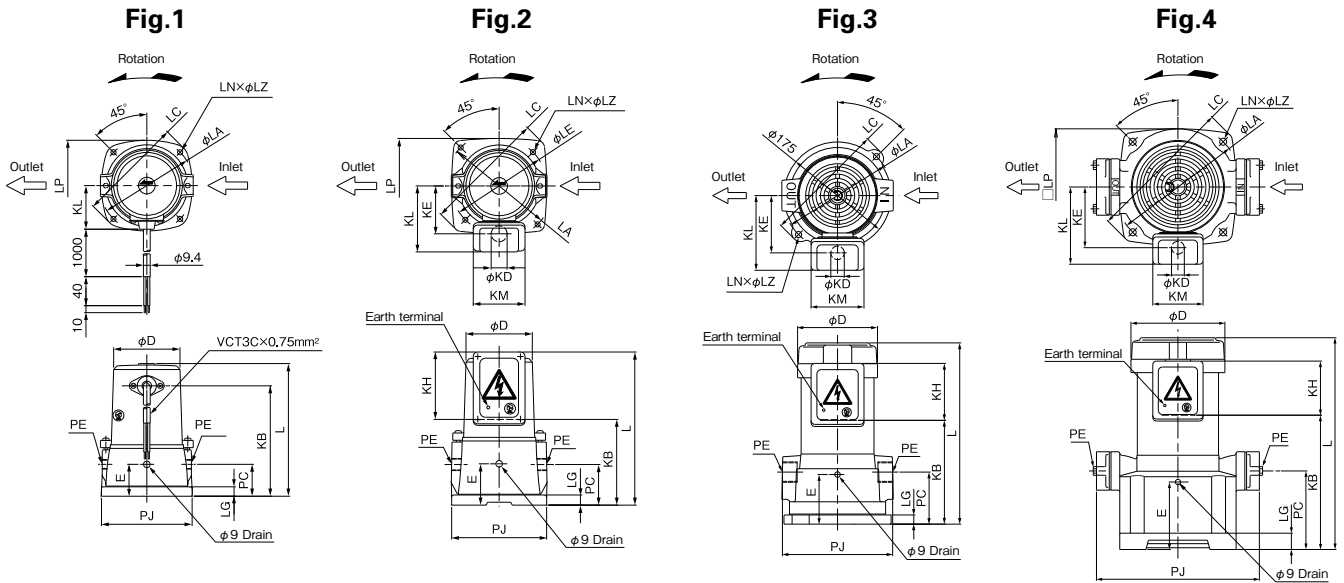

### Dimensions

(Unit: mm)

Type	Fig.	D	E	KB	KD	KE	KH	KL	KM	L	LA	LC	LE	LG	LN	LP	LZ	PC	PE	PJ	Approx. mass (kg)
VKN045L	1	92	44	151	—	—	—	61	—	183	130	145	—	13	4	125	7	44	Rp $\frac{1}{4}$	123	4.5
VKN045A(-4Z)	2	92	44	96	22	67	93	93	73	189	130	145	—	13	4	125	7	44	Rp $\frac{1}{4}$	125	4.5
VKN055A(-4Z)	2	92	57	119	22	67	93	93	73	212	130	169	132	14	4	131	7	56	Rp $\frac{3}{8}$	132	6.5
VKN065A(-4Z)	2	92	56	119	22	67	93	93	73	212	150	169	132	14	4	131	7	56	Rp $\frac{3}{8}$	132	7.5
VKN075A(-4Z)	2	111	63	143	22	78	93	104	73	236	164	194	160	15	4	153	10	63	Rp $\frac{1}{2}$	150	11.0
VKN085A(-4Z)	2	122	71	157	22	81	93	107	73	250	170	194	160	15	4	153	10	71	Rp $\frac{3}{4}$	160	12.5
VKN095A(-4Z)	3	131	81	169	22	94	93	122	87	296	180	200	—	15	2	—	10	85	Rp1	180	14.0
VKN115A(-4Z)	4	162	116	231	22	105	93	133	87	364	220	253	—	28	4	200	12	135	Rp1 $\frac{1}{2}$	280	29.0
VKN115A-G	4	162	116	231	22	105	93	133	87	364	220	253	—	28	4	200	12	135	Rp1 $\frac{1}{2}$	280	29.0
VKN115A-GS	4	162	116	231	27	108	93	146	94	364	220	253	—	28	4	200	12	135	Rp1 $\frac{1}{2}$	280	29.0

### Sectional drawing

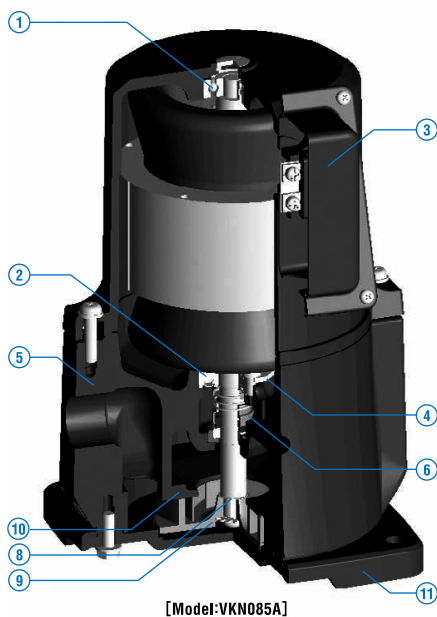

No.	Parts Name	Materials
1	Deep groove ball bearing	
2	Deep groove ball bearing	
3	Terminal box	SPCC
4	End cover	SPHC
5	Casing	FC150
6	Mechanical seal	Carbon/ceramic
8	Adjusting washer	BsP3-1 / 2H
9	Impeller	Special resin or CAC407
10	Eddy box	FC150
11	Bottom plate	FC150

Note: Structure and other details are subject to change without notice.

## Features

- ① About 30% pressure level increase compared with the standard type
- ② The motor and the pump are integrated for smaller sizes and lighter weights
- ③ With the self-priming function, the unit can be easily installed in confined areas
- ④ EU RoHS Directive (Restriction of Use of Six Hazardous Substances) compliant
- ⑤ Meets the EU Directive for CE marking
- ⑥ Enhanced protection against mist and other environmental elements

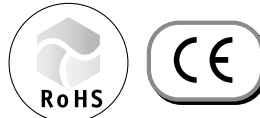

## Structure

Mechanical seal structure. The motor section and pump section are integrated and cast iron is used in the pump's main unit.

## How to read the model type

**VKN 07 5 H**

①      ②      ③      ④

- ① Model
- ② Output code (ex. 06: 100W)
- ③ Series
- ④ Number of phases and characteristics (H: 3 phases; pressure type)

## Selection chart (performance drawings)

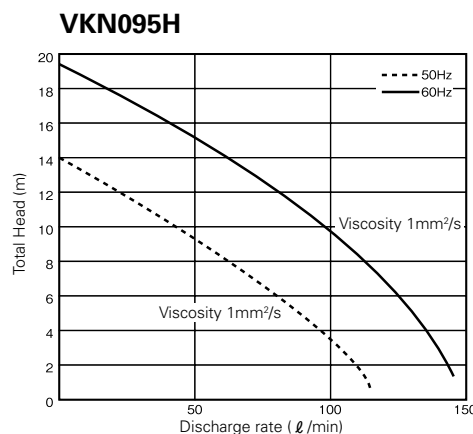
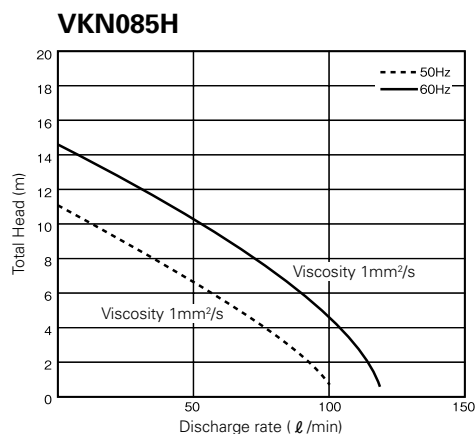
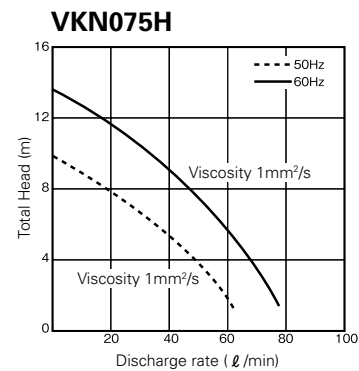
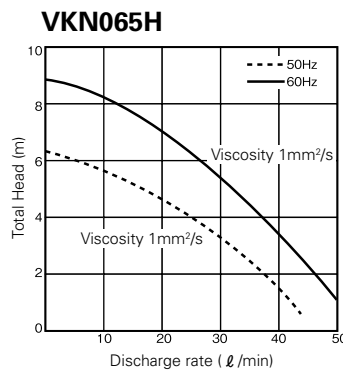
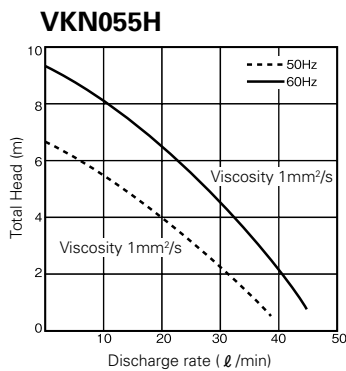

## Specifications

Specifications	Type	VKN055H		VKN065H		VKN075H		VKN085H		VKN095H	
Nominal output	(W)	60		100		180		250		400	
Rated voltage	(V)	200	200/220	200	200/220	200	200/220	200	200/220	200	200/220
Frequency	(Hz)	50	60	50	60	50	60	50	60	50	60
Rated current	(A)	0.42	0.55/0.52	0.55	0.6/0.6	0.9	1.2/1.1	1.2	1.5/1.5	2.4	2.5/2.4
Discharge rate	(l/min)	10	10	10	10	20	20	20	20	20	20
Total head	(m)	4.5	7	5	7.5	7	11	8	12	12	17
Max. length of suction pipe	(m)	0.7		0.7		0.7		0.6		0.6	
Max. viscosity allowed	(mm <sup>2</sup> /s)	37.5		37.5		37.5		37.5		37.5	
Inlet/outlet	(Rp)	3/8		3/8		1/2		3/4		1	
Paint color		Munsell N1									
Standard		IEC60034-1 CE approved									
Degree of protection		IP54									

Note: The discharge rate and total head values were obtained in tests with a liquid viscosity of 1mm<sup>2</sup>/s (same as tap water at normal temperature). Note that the pumps cannot be used with water.

### Assembly Drawing

Fig.1

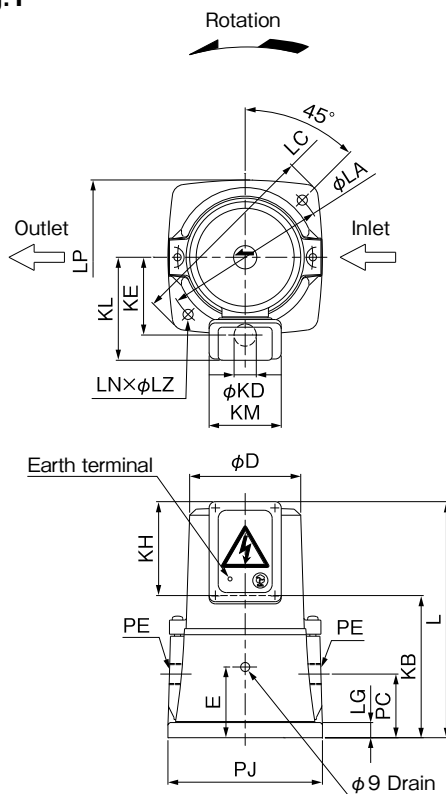
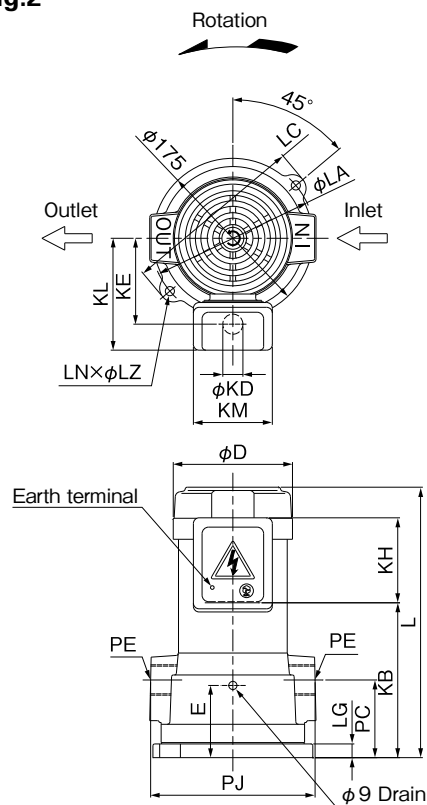

Fig.2



### Dimensions

(Unit: mm)

Type	Fig.	D	E	KB	KD	KE	KH	KL	KM	L	LA	LC	LG	LN	LP	LZ	PC	PE	PJ	Approx. mass (kg)
VKN055H	1	92	57	119	22	67	93	93	73	212	132	169	14	2	131	7	56	Rp $\frac{3}{8}$	132	6.5
VKN065H	1	92	57	119	22	67	93	93	73	212	132	169	14	2	131	7	56	Rp $\frac{3}{8}$	132	7.5
VKN075H	1	111	70	143	22	78	93	104	73	236	160	194	15	2	153	10	63	Rp $\frac{1}{2}$	150	11.0
VKN085H	1	122	73	157	22	81	93	107	73	250	160	194	15	2	153	10	71	Rp $\frac{3}{4}$	160	12.5
VKN095H	2	131	81	169	22	94	93	122	87	296	180	200	15	2	—	10	85	Rp1	180	14.0

### Sectional drawing

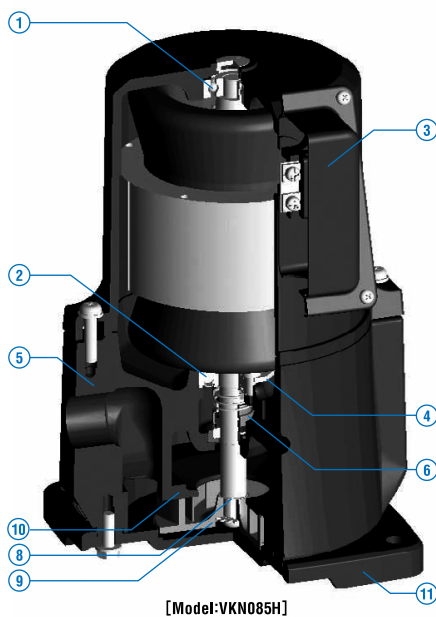

No.	Parts Name	Materials
1	Deep groove ball bearing	
2	Deep groove ball bearing	
3	Terminal box	SPCC
4	End cover	SPHC
5	Casing	FC150
6	Mechanical seal	Carbon/ceramic
8	Adjusting washer	BsP3-1 / 2H
9	Impeller	Special resin or CAC407
10	Eddy box	FC150
11	Bottom plate	FC150

Note: Structure and other details are subject to change without notice.

**Features**

- ① Not easily affected by dirty coolants
- ② The impeller is made of FCD and highly durable
- ③ Can be used for highly viscous coolants
- ④ With the tank for self-priming technology employed, these pumps are also installable outside a tank
- ⑤ China energy label regulation (GB18613-2012) efficiency-compliant unit (grade GB3) available

**Structure**

Non-seal (mechanical seal-less) structure. Cast iron is used in the pump's main unit.

**How to read the model type**

**LPS 40 3 C - 3.0 T**

- ①      ②      ③      ④      ⑤      ⑥      ⑦

- ① Model
- ② Pump's bore diameter
- ③ Number of impellers
- ④ Level of viscosity to be used with  
(C: For low viscosity, D: For high viscosity)
- ⑤ Output
- ⑥ ID code
- ⑦ Compliance with energy efficiency regulation (no description: standard)  
-G: China energy label regulation (GB18613-2012) efficiency-compliant unit (grade GB3) (200V, 50Hz)  
-GS: China energy label regulation (GB18613-2012) efficiency-compliant unit (grade GB3) (380V, 50Hz)



**Selection chart (performance drawings)**

● For low viscosity coolants (The following curves show performance of pump under condition of normal temperature freshwater with specific gravity of 1.)

**50Hz**

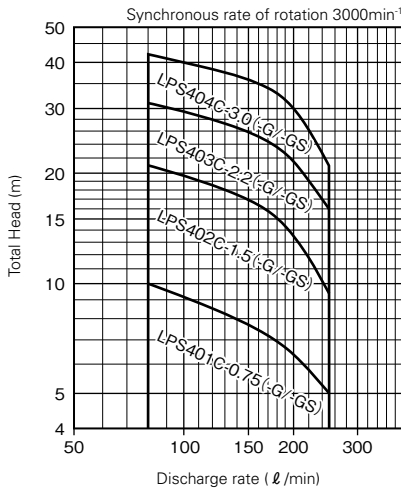

**60Hz**

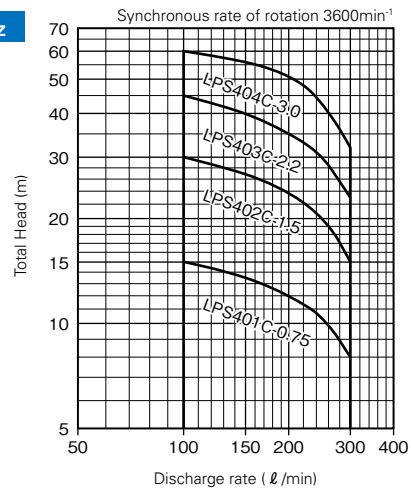

● For high viscosity coolants (The following curves show performance of pump under condition of 150cSt viscosity and specific gravity of 1.)

**50Hz**

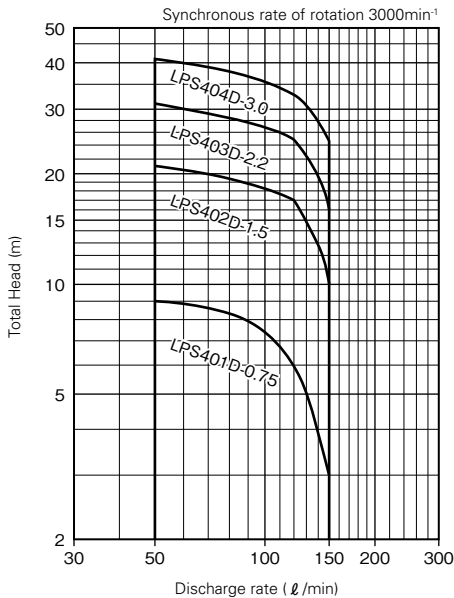

**60Hz**

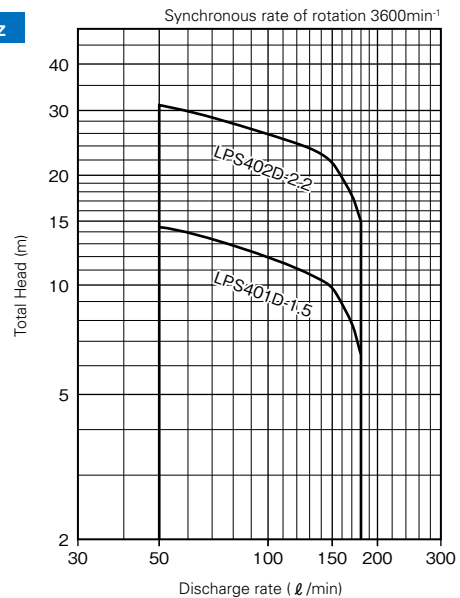



### Specifications

#### 50Hz

Type		Models for low viscosity coolants				Models for high viscosity coolants			
Type		LPS401C-0.75T	LPS402C-1.5T	LPS403C-2.2T	LPS404C-3.0T	LPS401D-0.75T	LPS402D-1.5T	LPS403D-2.2T	LPS404D-3.0T
Pump	Bore diameter (mm)	40							
	Discharge rate (ℓ/min)	80~250				50~150			
	Total head (m)	10~5	21~9.5	31~16	42~21	9~3	21~10	31~16	41~25
	Max. viscosity allowed (mm <sup>2</sup> /s)	32				150			
	Max. length of suction pipe	70cm							
Motor	Phases	3							
	No. of poles (P)	2							
	Rated output (kW)	0.75	1.5	2.2	3.0	0.75	1.5	2.2	3.0
	Rated voltage (V)	200							
	Rated current (A)	3.5	6.5	8.8	12.0	3.5	6.5	8.8	12.0
	Synchronous rate of rotation (min <sup>-1</sup> )	3000							
	Insulation class	E							
	Rating	Continuous							
	Method of protection	Totally enclosed fan cooled, indoor							
	Bearings	Load side	6306ZZ			6307ZZ	6306ZZ		
Non-load side		6204ZZ	6205ZZ		6206ZZ	6204ZZ	6205ZZ		6206ZZ
Ambient temperature (°C)	40 or below								
Paint color	Munsell N1.5								

#### ●China energy label regulation (GB18613-2012) efficiency-compliant unit (grade GB3)

Type		Models for low viscosity coolants							
Type		LPS401C-0.75T-G	LPS402C-1.5T-G	LPS403C-2.2T-G	LPS404C-3.0T-G	LPS401C-0.75T-GS	LPS402C-1.5T-GS	LPS403C-2.2T-GS	LPS404C-3.0T-GS
Pump	Bore diameter (mm)	40							
	Discharge rate (ℓ/min)	80~250							
	Total head (m)	10~5	21~9.5	31~16	42~21	10~5	21~9.5	31~16	42~21
	Max. viscosity allowed (mm <sup>2</sup> /s)	70cm							
	Max. length of suction pipe	32							
Motor	Phases	3							
	No. of poles (P)	2							
	Rated output (kW)	0.75	1.5	2.2	3.0	0.75	1.5	2.2	3.0
	Rated voltage (V)	200				380			
	Rated current (A)	3.8	6.1	8.9	14.3	2.0	3.3	5.2	7.5
	Synchronous rate of rotation (min <sup>-1</sup> )	3000							
	Insulation class	F							
	Rating	Continuous							
	Method of protection	Totally enclosed fan cooled, indoor							
	Bearings	Load side	6306ZZC3			6307ZZC3	6306ZZC3		
Non-load side		6203ZZC3	6303ZZC3		6205ZZC3	6203ZZC3	6303ZZC3		6205ZZC3
Ambient temperature (°C)	40 or below								
Paint color	Munsell N1.5								

With pumps for high viscosity coolants, contact us for further details.

#### 60Hz

Type		Models for low viscosity coolants				Models for high viscosity coolants	
Type		LPS401C-0.75T	LPS402C-1.5T	LPS403C-2.2T	LPS404C-3.0T	LPS401D-1.5T	LPS402D-2.2T
Pump	Bore diameter (mm)	40					
	Discharge rate (ℓ/min)	100~300				50~180	
	Total head (m)	15~8	30~15	45~23	64~32	14~4	31~13
	Max. viscosity allowed (mm <sup>2</sup> /s)	32				150	
	Max. length of suction pipe	70cm					
Motor	Phases	3					
	No. of poles (P)	2					
	Rated output (kW)	0.75	1.5	2.2	3.0	1.5	2.2
	Rated voltage (V)	200/220					
	Rated current (A)	3.5/3.4	6.5/6.1	9.0/8.2	11.5/10.7	6.5/6.1	9.0/8.2
	Synchronous rate of rotation (min <sup>-1</sup> )	3600					
	Insulation class	E					
	Rating	Continuous					
	Method of protection	Totally enclosed fan cooled, indoor					
	Bearings	Load side	6306ZZ			6307ZZ	6306ZZ
Non-load side		6204ZZ	6205ZZ		6206ZZ	6205ZZ	
Ambient temperature (°C)	40 or below						
Paint color	Munsell N1.5						

※ These pumps work with coolants containing an additive (anticorrosive, etc.), for instance water-soluble and water-insoluble coolants. Do not, however, use these pumps with freshwater.

### Special specifications

- Can be used for high viscosity coolants.
- Sealing structure is modified (to improve abrasion resistance).

Selection chart (performance drawings)

(The following curves show performance of pump under condition of normal temperature freshwater with specific gravity of 1.)

50Hz

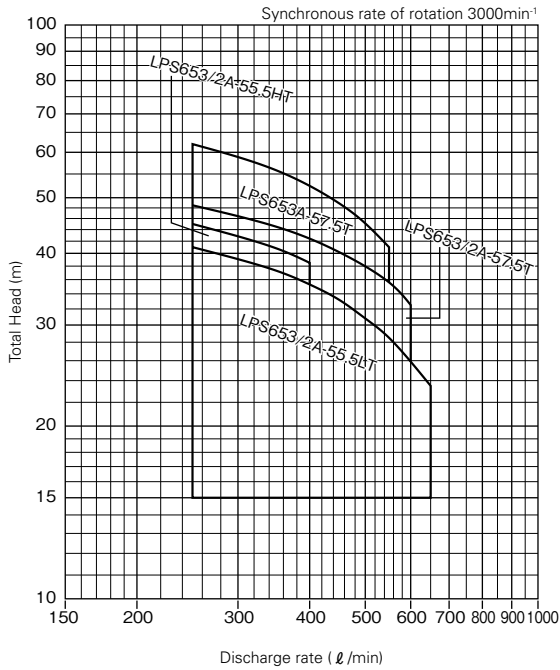

Specifications

50Hz

Type		LPS653/2A-55.5LT	LPS653/2A-55.5HT	LPS653/2A-57.5T	LPS653A-57.5T
Pump	Bore diameter (mm)	65			
	Discharge rate (ℓ/min)	250~650	250~400	250~600	250~550
	Total head (m)	41~23.5	45~38.5	48.5~32.5	62~41
	Coolants to be used	Water-soluble coolants			
Max. length of suction pipe		700			
Motor	Phases	3			
	No. of poles (P)	2			
	Output (kW)	5.5		7.5	
	Voltage (V)	200			
	Rated current (A)	21		27.8	
	Synchronous rate of rotation (min <sup>-1</sup> )	3000			
	Insulation class	B			
	Ambient temperature (°C)	40 or below			
	Rating	Continuous			
	Method of protection	Totally enclosed fan cooled, indoor			
Bearings	Load side	6308ZZ			
	Non-load side	6306ZZ			
Paint color		Munsell N1.5			

\* For China energy label regulation (GB18613-2012) efficiency-compliant unit (grade GB3), contact us for further details.

60Hz

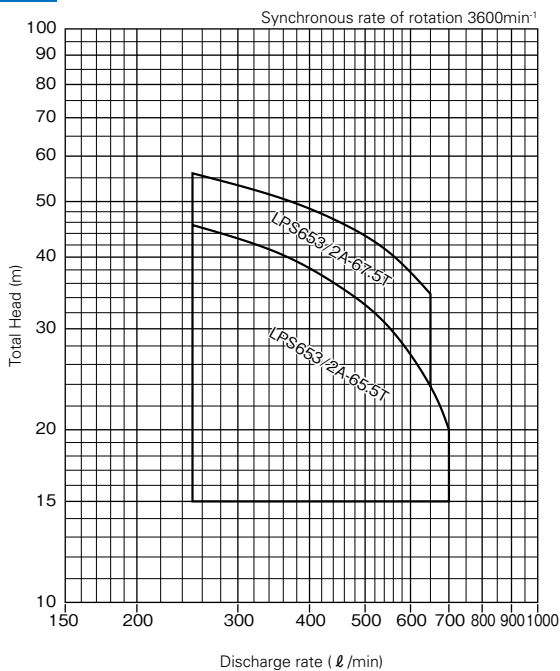

60Hz

Type		LPS653/2A-65.5T	LPS653/2A-67.5T
Pump	Bore diameter (mm)	65	
	Discharge rate (ℓ/min)	250~700	250~650
	Total head (m)	45.5~20	56~34.5
	Coolants to be used	Water-soluble coolants	
Max. length of suction pipe		700	
Motor	Phases	3	
	No. of poles (P)	2	
	Output (kW)	5.5	7.5
	Voltage (V)	200/220	
	Rated current (A)	20	26.6
	Synchronous rate of rotation (min <sup>-1</sup> )	3600	
	Insulation class	B	
	Ambient temperature (°C)	40 or below	
	Rating	Continuous	
	Method of protection	Totally enclosed fan cooled, indoor	
Bearings	Load side	6308ZZ	
	Non-load side	6306ZZ	
Paint color		Munsell N1.5	

## Assembly Drawing

### ●LPS40

Fig.1

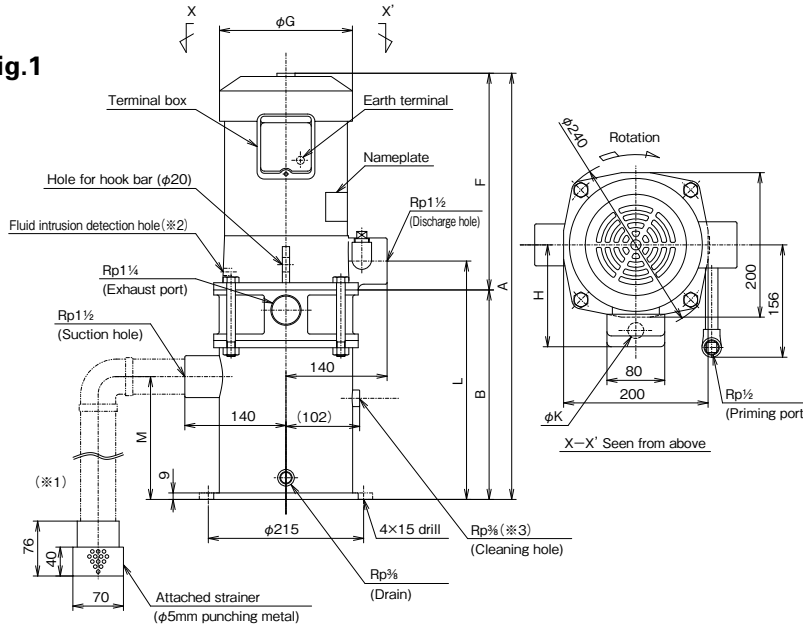
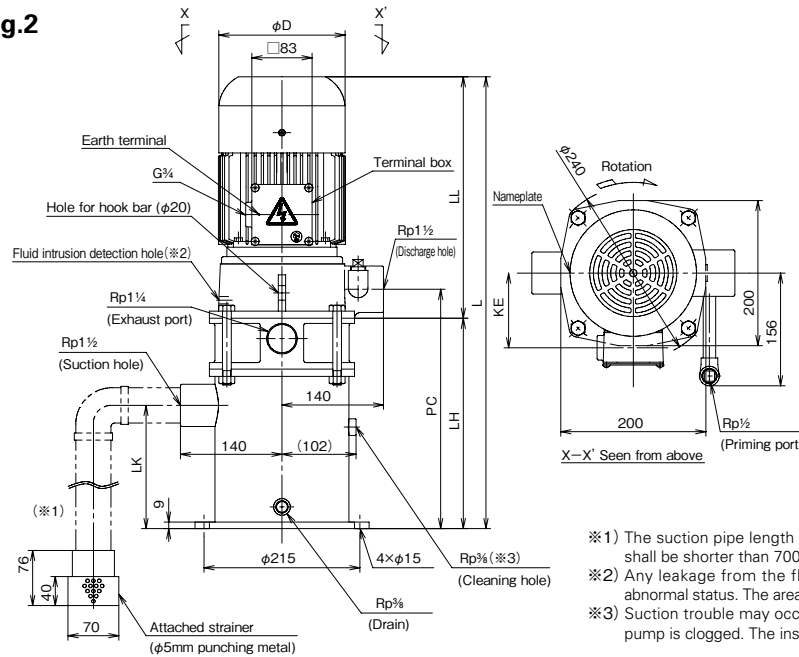

Fig.2



- ※1) The suction pipe length from the liquid surface to the suction port shall be shorter than 700 mm.
- ※2) Any leakage from the fluid intrusion detection hole indicates an abnormal status. The area around the exhaust port shall be inspected.
- ※3) Suction trouble may occur if the siphon prevention hole inside the pump is clogged. The inside shall be inspected via the cleaning hole.

## Dimensions

### ●LPS40

(Unit: mm)

		Type	Fig.	D	KD	KE	KL	L	LH	LK	LL	PC	Approx. mass (kg)	
For low viscosity coolants	For both 50Hz and 60Hz	LPS401C-0.75T	1	162	22	—	132	567	290	170	277	330	40	
		LPS402C-1.5T		184			590	300			43			
		LPS403C-2.2T		215	27		614	324	52					
		LPS404C-3.0T			158		710	335	215		375	375	64	
	50 Hz	LPS401C-0.75T-G	2	140	—	88	—	578	—	290	170	288	330	40
		LPS401C-0.75T-GS		174										103
		LPS402C-1.5T-GS			195	113	—	699	335	215	364	375	64	
		LPS403C-2.2T-G		—									—	—
		LPS403C-2.2T-GS			—	—	—	—	—	—	—	—		
		LPS404C-3.0T-G		—									—	—
		LPS404C-3.0T-GS			—	—	—	—	—	—	—	—		
		For high viscosity coolants		50 Hz									LPS401D-0.75T	1
LPS402D-1.5T	184		590		300	43								
LPS403D-2.2T	215		27		614	324	52							
LPS404D-3.0T			158		710	335	215	375	375	64				
60 Hz	LPS401D-1.5T		—	—	—	—	—	—	—	—	—	—	—	42
	LPS402D-2.2T													184

※Do not immerse the end of the draining pipe from the pump's exhaust port in coolant.

Assembly Drawing

●LPS65

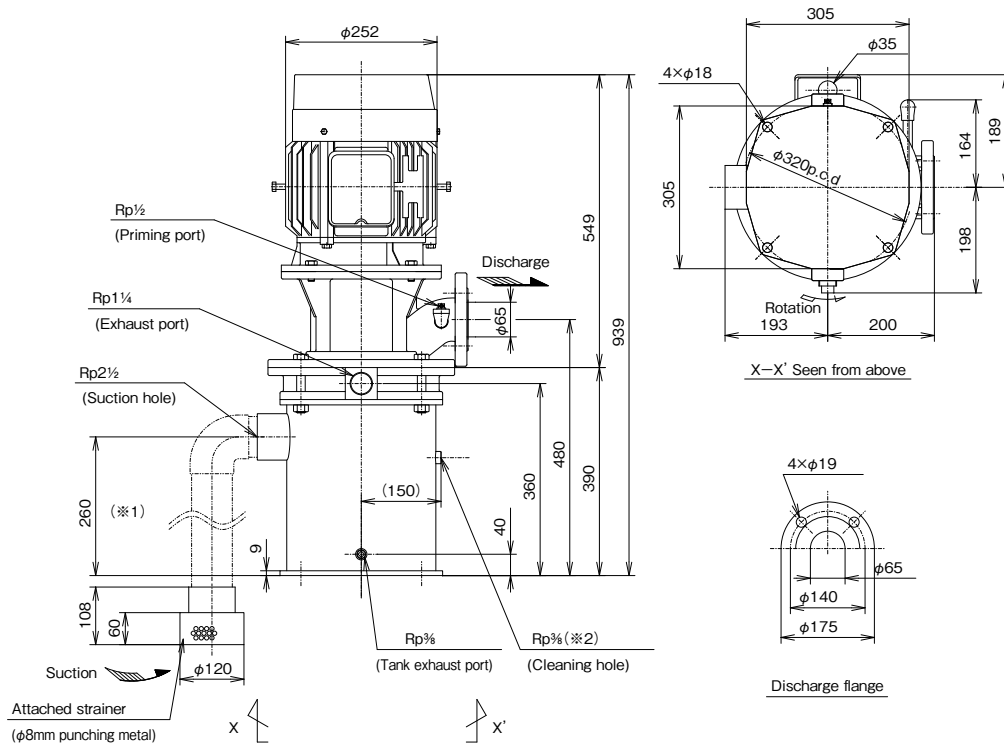

- ※1) The suction pipe length from the liquid surface to the suction port shall be shorter than 700 mm.
- ※2) Suction trouble may occur if the siphon prevention hole inside the pump is clogged.  
The inside shall be inspected via the cleaning hole. (Companion Flange JIS 10K normal type is supplied.)

Dimensions

●LPS65

Type	Frequency (Hz)	Bore diameter (mm)	Rotation (min <sup>-1</sup> )	Output (kW)	Approx. mass (kg)
LPS653/2A-55.5LT	50	65	3000	5.5	127
LPS653/2A-55.5HT					127
LPS653/2A-57.5T				129	
LPS653A-57.5T	60		3600	5.5	131
LPS653/2A-65.5T					127
LPS653/2A-67.5T				129	

\* For China energy label regulation (GB18613-2012) efficiency-compliant unit (grade GB3), contact us for further details.

#### Sectional drawing

##### ●LPS40

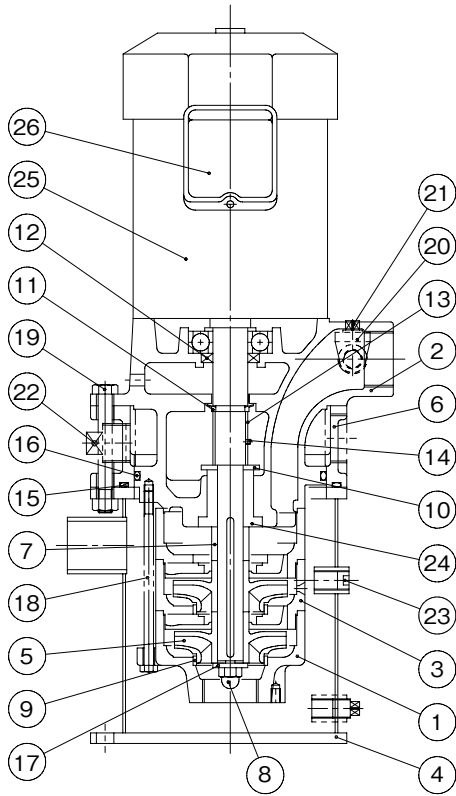

No.	Parts Name	Qty	Materials
1	Suction casing	1	FC200
2	Discharge casing	1	FC200
3	Intermediate casing	2	FC200
4	Suction pipe	1	SS400
5	Impeller	2	FCD450
6	Suction spacer	1	FC200
7	Shaft spacer	1	STS
8	Impeller nut	1	SUS304
9	Wearing ring	2	SUS304
10	Deflector	1	SS400
11	Deflector	1	NBR
12	Oil seal	1	NBR
13	Collar	1	STKM
14	Hexagonal socket set screw	1	SCM435
15	O-ring	1	NBR
16	O-ring	1	NBR
17	Washer	1	SUS420J1
18	Tie bolt	4	SS400
19	Tie bolt	4	SS400
20	Elbow	1	FCMB
21	Plug	1	SS400
22	Plug	1	FCMB
23	Hexagonal socket sunk plug	1	SS400
24	Shaft sleeve	1	FCD450
25	Motor	1	
26	Terminal box	1	SECC

Applicable models: LPS402C-1.5T · LPS402D-1.5T · LPS402D-2.2T

##### ●LPS65

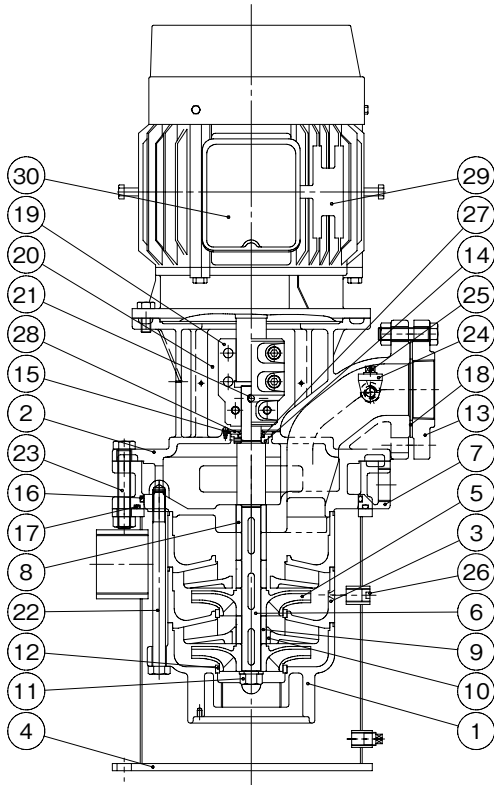

No.	Parts Name	Qty	Materials
1	Suction casing	1	FC200
2	Discharge casing	1	FC200
3	Intermediate casing	2	FC200
4	Suction pipe	1	SS400
5	Impeller	2	FCD450
6	Shaft	1	S45C
7	Suction spacer	1	FC200
8	Shaft sleeve A	3	SUS304
9	Shaft sleeve B	1	SIC
10	Intermediate bush	1	SIC
11	Impeller nut	1	SUS304
12	Wearing ring	3	SUS304
13	Companion flange	1	FC200
14	Deflector	1	C3604B
15	O-ring	1	NBR
16	O-ring	1	NBR
17	O-ring	1	NBR
18	Sheet packing	1	NBR
19	Coupling	1	FC200
20	Coupling cover	2	SUS304
21	Hexagonal socket set screw	1	SCM435
22	Tie bolt	4	SS400
23	Tie bolt	4	SS400
24	Elbow	1	FCMB
25	Plug	1	SS400
26	Hexagonal socket sunk plug	1	SS400
27	V-ring	1	VITON
28	Coolant sealing plate	1	SUS304
29	Motor	1	ADC
30	Terminal box	1	SPCC

Applicable models: 50Hz LPS653/2A-55.5LT, LPS653/2A-55.5HT, LPS653/2A-57.5T  
60Hz LPS653/2A-65.5T, LPS653/2A-67.5T

Features

- ① Bubbles and chips floating on the liquid surface can be suctioned continuously
- ② Impeller allowing simultaneous suction from both above and below is adopted (a patent)
- ③ Complete exhaust structure to prevent air lock (a patent)
- ④ V-shaped inlet allowing suction even when fluid level fluctuates (a patent)

How to read the model type

**SKM-C 50**

①                      ②

- ① Model
- ② Discharge rate (ℓ/min)



Selection chart (performance drawings)

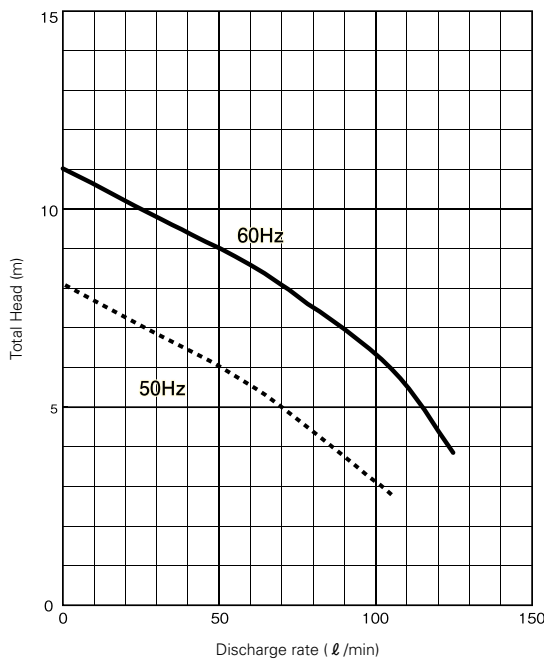

- Note 1: The pump's performance represents the performance when used with the recommended surface level.
- Note 2: The pump's performance may change depending on the fluid level during operation.
- Note 3: If the liquid level during operation is high or discharge is low, suction of the surface water will decrease.
- Note 4: The pump shall be installed in a place where the surface water is stable.
- Note 5: The pump shall be used at a level higher than the minimum fluid level.
- Note 6: Suction is carried out only from the lower inlet if the fluid level is lower than the suction slit.

Specifications

Type		SKM-C50	
Pump	Bore diameter (mm)	20	
	Discharge rate (ℓ/min)	50	
	Total head (m)	6	9
	Max. viscosity allowed (mm <sup>2</sup> /s)	1	
	Liquid filtration accuracy	Medium filtration accuracy (Max. chip size allowed to transit the pump: 4 mm)	
	Material	Casing FC Impeller SUS304 Shaft S35C	
Motor	Phases	3	
	No. of poles (P)	2	
	Output (kW)	0.25	
	Voltage (V)	200	200/220
	Rated current (A)	1.6	1.7/1.6
	Frequency (Hz)	50	60
	Synchronous rate of rotation (min <sup>-1</sup> )	3000	3600
	Insulation class	B	
	Ambient temperature (°C)	40 or below	
	Rating	Continuous	
	Method of protection	Totally enclosed self-cooling type	
	Bearings	Load side	6203ZZ
	Non-load side	6201ZZAC	
Approx. mass (kg)	14		
Paint color	Munsell N5.5		

Assembly Drawing

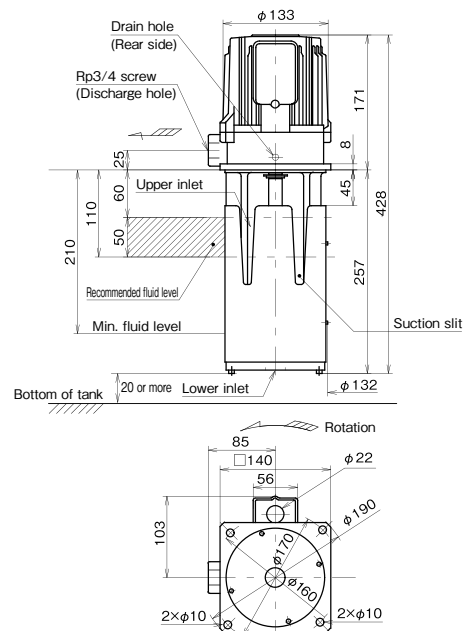

The pump characteristics vary significantly with pipe routing. Head loss due to pipe length and fittings can be greater than expected. Pipes should be as short as possible, and the number of bends such as elbows, fittings and valves as few as possible when designing pipe routing. Head loss is calculated as shown below.

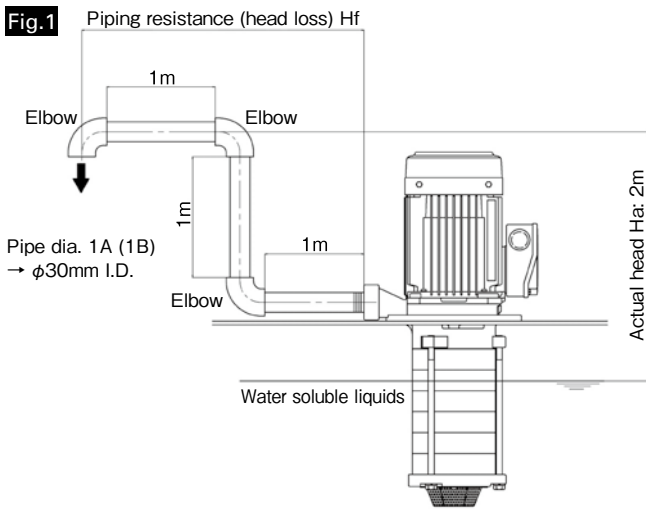

**Calculate the total head required to deliver 50ℓ/min in Fig. 1.**

Total head is given by  $H_t = H_a + H_f$  [m], where  $H_a$  and  $H_f$  are actual head [m] and head loss [m], respectively.

In Fig. 1, actual head  $H_a$  is 2m and head loss  $H_f$  (※1) 0.79m. Total head  $H_t$  is therefore 2.79m ( $H_a + H_f = 2 + 0.79$ ).

To deliver 50ℓ/min, a pump with total head of 2.79m or above is required (Fig. 2).

Note: This is a calculation value. The actual pump operating point varies significantly depending on the type of liquids used, viscosity and piping.

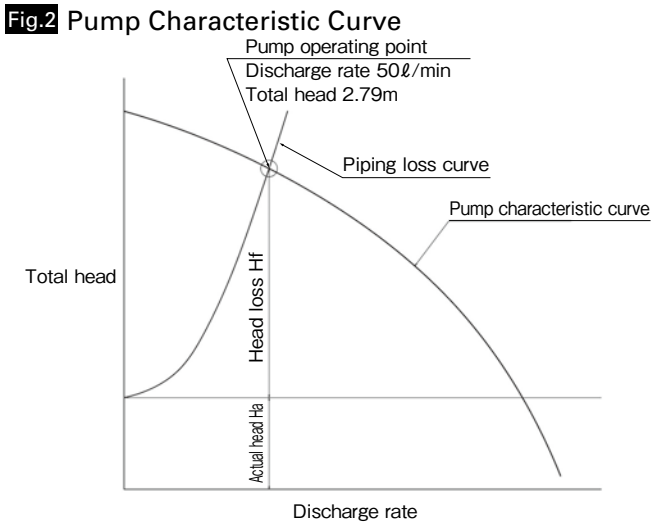

### ※1 How to Obtain Head Loss

Head loss is given by  $H_f = f \times (L/d) \times V^2/2g$  [m], where:

**f: Loss coefficient (determined by Reynolds number)**

**L: Equivalent horizontal length [m] (※2)**

**V: Flow velocity [m/s]**

**d: Pipe I.D. [m]**

**g: Gravitational acceleration 9.8 [m/s<sup>2</sup>]**

In Fig.1, Head loss  $H_f = 0.03 \times (11.1/0.03) \times 1.18^2 / (2 \times 9.8) = 0.79$ m

Note: Loss coefficient of water-soluble liquids is assumed 0.03. Oil-based liquids have a much larger value.

Table1 Equivalent Horizontal Length of Elbows and Other Components as a Guide

Nominal Size	Inflow	Outflow	90-deg elbow	Ball valve
8A (1/4B)	0.3	0.6	0.7	6.4
10A (3/8B)	0.4	0.8	0.9	6.7
15A (1/2B)	0.6	1.2	1.1	6.7
20A (3/4B)	0.8	1.6	1.3	7.3
25A (1B)	1.1	2.2	1.6	8.8
40A (1 1/2B)	1.9	3.2	2.3	12.8

[m]

### ※2 How to Obtain the Equivalent Horizontal Length

In Fig. 1,

**Straight pipes: 1m + 1m + 1m = 3m**

**Elbows: 1.6m + 1.6m + 1.6m = 4.8m**

**Inflow: 1.1m**

**Outflow: 2.2m**

**Equivalent horizontal length L is therefore 3m + 4.8m + 1.1m + 2.2m = 11.1m**

Note: Equivalent horizontal length of elbows and other components is shown in Table 1 as a guide.

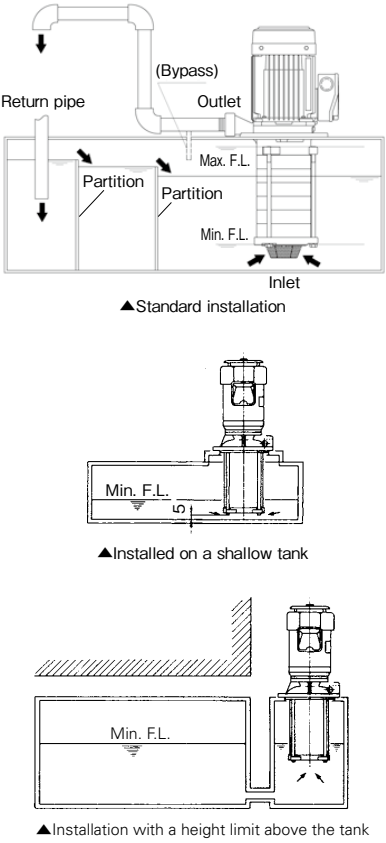
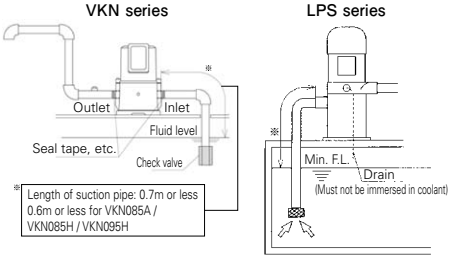
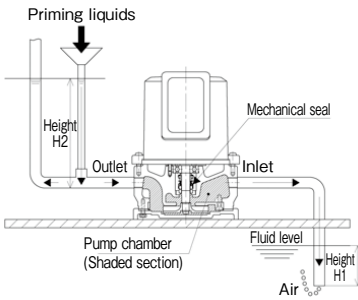
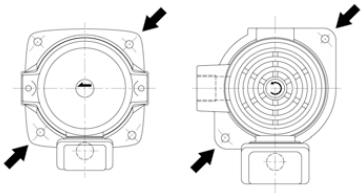
Item	Type	Description
Installation	Immersion type	 <ul style="list-style-type: none"> <li>• Piping should be as short as possible and the number of bends such as elbows, fittings and valves as few as possible. Use pipes of a standard size. The discharge rate will decrease if the pipes are thin or have many bends.</li> <li>• Provide effective support for the pipes so as to prevent the pipe weight from being directly applied to the pump.</li> <li>• Do not forcibly screw the pipe into the pump. The fitting may be destroyed.</li> <li>• Prevent liquid or air leakage from the pipe thread joints by applying seal tape or the like. Correctly apply the tape so as not to close off the piping.</li> <li>• Use a tank (oil tank) of a large capacity to the extent possible.             <ul style="list-style-type: none"> <li>*The recommended capacity is at least three times the discharge rate per minute. If the capacity is not sufficient, the discharge rate will decrease or other problems will occur due to a rise in liquid temperature during operation, premature clogging of the strainer due to chips and air bubbles.</li> <li>*Slowly pour the liquid into the tank to prevent air from being introduced simultaneously.</li> </ul> </li> <li>• Prevent chips, dust and other foreign matter from entering the pump.             <ul style="list-style-type: none"> <li>*We recommend installing an overflow unit of three or more steps and a filter.</li> </ul> </li> <li>• If water hammer is likely to occur, take preventive measures such as installing a bypass after the pump outlet.</li> <li>• If the fluid level is too low, air will be introduced to decrease the discharge rate or the liquids may not be pumped. The fluid level must not be lower than the recommended minimum fluid level (Min. F.L.) shown in the Assembly Drawings. This level varies with viscosity. For safety purposes, the actual fluid level should be sufficiently high. On the other hand, the liquids will enter the motor through drain holes if the fluid level is too high, resulting in motor failure. The fluid level must not exceed the maximum fluid level (Max. F.L.) shown in the Assembly Drawings.</li> </ul>
	Self-priming type	 <ul style="list-style-type: none"> <li>• The pump shall be installed as close to the tank as possible so that the suction pipe is short. The maximum length of the suction pipe should be 0.7 m (0.6 m for VKN085A, VKN085H and VKN095H). If a long suction pipe must be used, a check valve shall be installed in the suction piping. Sealing tape shall be used for the pipe screw-in position to prevent fluid and air leakage. Particularly, air leakage from the suction hole should be avoided because it may result in decreasing the flow rate or insufficient pumping performance.</li> </ul>
Priming liquids	Self-priming type	 <ul style="list-style-type: none"> <li>• After installation, deaeration by priming is necessary because air is stored in the pump chamber (shaded section in the figure below) at initial start-up or start-up after a long interval. The air in the pump chamber may result in some problems including poor suction or failure to achieve pump performance (insufficient flow rate or pressure). Further, if the pump is operated for a long time without suctioning the fluid, mechanical seal damage or other damage may occur.</li> </ul> <p><b>[How to Prime]</b></p> <p>VKN Series</p> <ul style="list-style-type: none"> <li>• Pour the liquid from the discharge side until air is completely eliminated from the pump chamber, or until air no longer comes out of the tip of the suction pipe. Note that the priming liquids will not completely enter the pump if height H2 from pump outlet to the priming liquid opening is smaller than the length H1 of the suction pipe below the fluid level. In this case, install an air vent for priming on the suction pipe or sufficiently increase the height of the priming liquid opening.</li> </ul> <p>LPS Series</p> <ul style="list-style-type: none"> <li>• For priming, the liquid shall be supplied from the priming port of the pump discharge hole until the liquid appears from the suction pipe.</li> </ul>
Installation	VKN VKP	 <ul style="list-style-type: none"> <li>• The VKN/VKP Series has 4 mounting holes (except some models). Only one set of diagonally opposed holes is used for securing the unit. The other is provided to allow for possible extended applications. (One set is to the JEM and the other to the company standard dimensions.)</li> </ul> <p>VKN/VKP Series mounting holes Arrow marks: JEM dimensions</p>

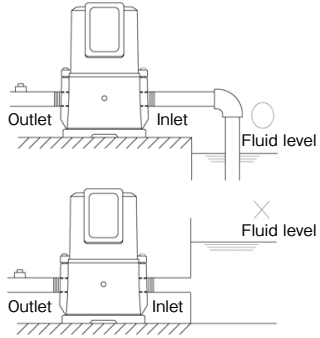
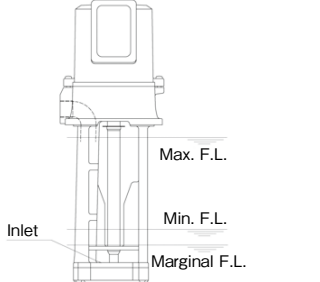
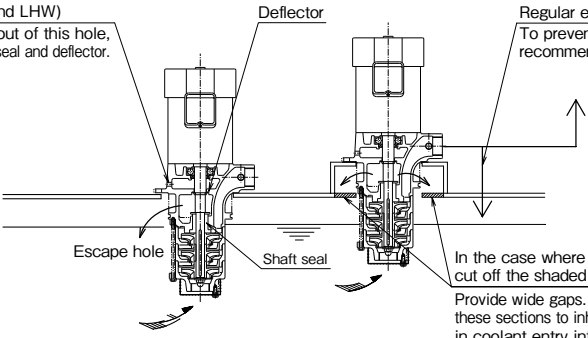
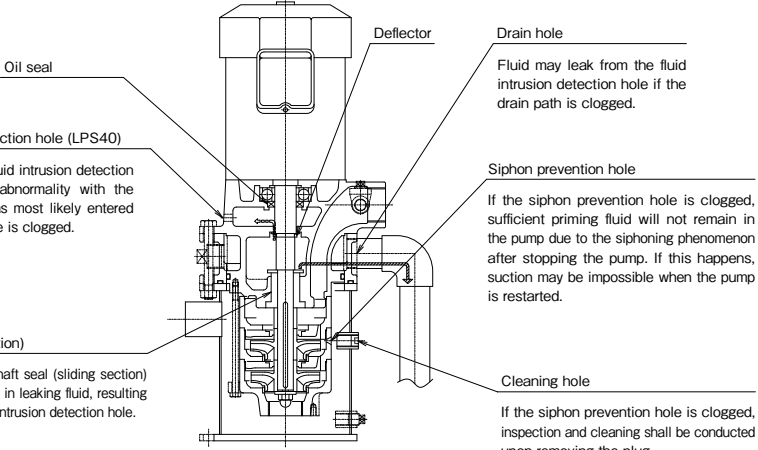

Item	Type	Description
Fluid level	VKN	 <p>•The fluid level for the VKN series must be lower than the pump inlet. The liquids may leak from the mechanical seal if the fluid level is higher than the pump inlet.</p>
	VKP	 <p>•For VKP Series pumps, the suction faces upward, Marginal fluid level is shown in the Assembly Drawings in addition to maximum fluid level.  <b>Minimum fluid level (Min. F.L.)</b>  Indicates the range where the discharge rate is almost the same as the rating and air is not introduced.  <b>Marginal fluid level (Marginal F.L.)</b>  Indicates the range where air is introduced and the discharge rate is about one-half of the rating.  <b>Maximum fluid level (Max. F.L.)</b>  Must clear the pump flange by at least 20mm.</p>
How to prevent problems with immersion-type pumps	 <p>Fluid leakage detection hole (Models LPW and LHW) If liquid comes out of this hole, replace the shaft seal and deflector.</p> <p>Deflector</p> <p>Regular escape piping recommended. To prevent the problem of air accumulation, it is recommended to create a path that releases air.</p> <p>Escape hole</p> <p>Shaft seal</p> <p>In the case where the pump is elevated, cut off the shaded sections. Provide wide gaps. Otherwise, chips will build up on these sections to inhibit discharging, which may result in coolant entry into the motor.</p>	
	How to prevent problems with self-priming-type pumps	VKN
LPS		<p><b>LPS40 Series</b></p>  <p>Oil seal</p> <p>Fluid intrusion detection hole (LPS40) Leakage from the fluid intrusion detection hole indicates an abnormality with the drain path. Fluid has most likely entered the motor if this hole is clogged.</p> <p>Shaft seal (Sliding section) Excessive abrasion on shaft seal (sliding section) may result in an increase in leaking fluid, resulting in leakage from the fluid intrusion detection hole.</p> <p>Deflector</p> <p>Drain hole Fluid may leak from the fluid intrusion detection hole if the drain path is clogged.</p> <p>Siphon prevention hole If the siphon prevention hole is clogged, sufficient priming fluid will not remain in the pump due to the siphoning phenomenon after stopping the pump. If this happens, suction may be impossible when the pump is restarted.</p> <p>Cleaning hole If the siphon prevention hole is clogged, inspection and cleaning shall be conducted upon removing the plug.</p> <p>Note: While the structure of LPS65 is different from that shown above, the same advice is applicable to the shaft seal (sliding section), drain hole, siphon prevention hole and cleaning hole.</p>

Item	Description
General	<ul style="list-style-type: none"> <li>• Thoroughly read all instructions provided in the instruction manual before handling the unit (installation, transportation, maintenance, inspection, etc.) and use the unit correctly. Familiarize yourself with the mechanisms of the unit, and safety and handling procedures before using the unit. Like maintenance and inspection of the unit after start-up, proper handling after purchase of the unit and until start of actual operation is indispensable in operating the unit to its full performance potential, preventing accidents and ensuring satisfactory operation for many years to come.</li> <li>• Do not work with live circuits. Work on the unit only after turning the main power off.</li> <li>• Turn the main power switch off in the case of power failure.</li> <li>• Immediately stop the unit and turn the main power switch off if an anomaly is detected.</li> <li>• Securely connect the earth terminal to the ground.</li> <li>• Piping and wiring of the unit should be performed according to the Technical Standard for Electric Facilities and Internal Wiring Standards.</li> <li>• Protective devices are not included in the unit. Installation of an overcurrent protective device is mandatory as specified in the Technical Standard for Electric Facilities. We recommend installing other protective devices (e.g. ground-fault circuit interrupter) in addition to the overcurrent protective device to prevent burnout of the unit.</li> <li>• Provide sufficient dust- and drip-proof measures using connectors, glands, etc., so that cutting chips, coolant solutions or any other foreign matter will not enter the terminal box through external wiring ports. Keep the grommets in place at the external wiring ports that are not used.</li> <li>• Electric current will increase and the motor will burn out if voltage drops significantly. The thermal relay can also trip.</li> <li>• Do not use the unit in an explosive atmosphere.</li> <li>• Never place flammable substances near the unit.</li> <li>• Increased-safety and explosion-proof type coolant pumps cannot be manufactured.</li> <li>• The unit may not be used for kerosene, gasoline or other volatile liquids.</li> <li>• Never approach or touch the rotating components of the unit (external fan, impeller, etc.) during operation.</li> <li>• Do not insert your fingers or objects into the openings of the unit (fan cover, pump inlet and outlet, drain hole, etc.).</li> <li>• Never step on the unit.</li> <li>• The unit can become very hot during operation. Never touch it with your hands or body.</li> <li>• Clear the area around the unit to ensure free air ventilation.</li> <li>• Install the unit in a place where the unit is easily maintained and inspected (avoid a confined area).</li> <li>• Install the unit on a flat and level place. Make sure the unit will not rattle.</li> <li>• The maximum allowable external vibration acceleration for the unit is about 4.9 to 6.9m/s<sup>2</sup>.</li> <li>• Operation frequency may not exceed 60Hz when an inverter is used in drive. Resonance can occur arbitrarily depending on pump installation conditions. Avoid using the unit at resonance-inducing frequencies.</li> <li>• The motor service life will be reduced and risk of burnout will exist if the viscosity of the liquids in use is too high. Observe the limit of the allowable viscosity [mm<sup>2</sup>/s] stated in the specifications for the unit. Viscosity can increase considerably when the temperature of the liquid drops. Check the viscosity of the liquid for the lowest specified temperature of the liquid.</li> <li>• The unit is designed for use with coolants such as grinding and cutting fluids. For the pumps incorporating mechanical seals (VKA/VKC/VKH/VKN), the life of the mechanical seals will be considerably reduced if hard sludge such as grinding powder, abrasives and diamond grains is present in the liquids. Install suitable filters (magnet or paper filter, etc.). The unit is not used for special liquids (printing and acidic liquids). Contact us when using the unit for other special liquids (e.g. ceramic).</li> <li>• Check the direction of rotation before connecting the unit to the customer's system.</li> <li>• For pumps provided with an air vent valve, open the valve slightly when starting up the unit and make sure that the liquids are discharged from the valve. Firmly close the valve after checking.</li> <li>• As this is a centrifugal pump, the flow rate can be freely adjusted by controlling the valve on the discharge side. The motor is not overloaded when the valve is shut off. However, if you perform shut-off operation with a pump provided with mechanical seals, allow a small flow rate quantity (0.1ℓ/min or more) to continually flow by, for example, installing a bypass.</li> <li>• Repair, disassembly and modification of the unit must be performed by an expert.</li> <li>• Modification of the unit by the customer relieves us of our responsibility for the product. We shall not be responsible for such modification including the results thereof.</li> <li>• Dispose of the unit, when necessary, as general industrial waste.</li> <li>• We also manufacture units of different voltages in addition to the specifications mentioned in this catalog. Contact us for further details.</li> </ul>

### When placing orders:

We request detailed consultations with our customers about specifications in order to manufacture reliable products that fully meet the customers' request.

Please confirm the following points when you make an inquiry or place an order for our Coolant Pumps.

- (1) **Use** : For special uses other than machine tools, carefully consider whether the unit can be actually used or contact us.
- (2) **Use liquid** : Type, viscosity, temperature, acidity, contamination with foreign matter
- (3) **Pump specifications** : Total head, discharge quantity, suction head (self-priming height)
- (4) **Motor specifications** : Output, voltage, frequency, number of phases
- (5) **Usage conditions** : Air ventilation, ambient temperature
- (6) **Terminal** : Terminal marking, number of terminals, terminal box structure, etc.
- (7) **Piping method** : Piping diagram
- (8) **Installation method** : Distinction between self-priming type and non-self-priming type
- (9) **Type of our unit** : e.g. VKA166AQ
- (10) **Applicable standards**
- (11) **Other** : Noise, vibration, specification of characters to be printed on nameplate, etc.



Your Dealer

**TERAL**

**TERAL INC.**

Head Office 230, Moriwake, Miyuki-cho, Fukuyama-city, Hiroshima, 720-0003, Japan Tel.+81-84-955-1111 Fax.+81-84-955-5777  
[www.teral.net](http://www.teral.net)

**TERAL ASIA LTD.**

Room 1001, 10/F, Olympia Plaza, 255 King's Road, North Point, Hong Kong Tel.+852-2571-0886 Fax.+852-2571-0619

**TERAL THAI CO., LTD.**

**TERAL TRADING & SERVICE CO., LTD.**

150 Moo 16 Udomsoraryuth Rd., T.Bangkrasan, A.Bangpa-In, Ayutthaya 13160 Thailand Tel.+66-3522-0640 Fax.+66-3522-1259

**TERAL GENERAL MACHINE (SHANGHAI) CO., LTD.**

No.285, Yuan Qu Road(N), Bei Qiao, Min Hang District, Shanghai 201109, China Tel.+86-21-6490-9128 Fax.+86-21-6490-9126