

**TERAL**

# TERAL WATER SUPPLY SERIES

**NX-VFC** NXV | MC4 | NX-PCL | NX-LAT | THP5-V

50Hz/60Hz

*Japan's cutting edge water supply system.*



TERAL INC.

# TERAL WATER

**TERAL's newest water supply system for the world.**



Estimated constant terminal-pressure control

|                              | Small type  | Multiple pump control   |  |  |
|------------------------------|---|---|--|--|
|                              | <b>NX-VFC</b>   | <b>NX-VFC multiple pump control</b>   | <b>NXV high head</b>   | <b>NVV high head vertical type</b>   |
| Max number of operable pumps | 2   | 5   | 5  | 5  |
| Voltage (V)                  | 3-phase · 380/400/440   | 3-phase · 380/400/440   | 3-phase · 380/400/440  | 3-phase · 380/400/440  |
| Output range (kW)            | 0.4~7.5   | 1.1~7.5   | 7.5~15   | 15~18.5  |
| Flow (m <sup>3</sup> /min)   | 0.02~1.13   | 0.04~3.04   | 0.1~3.25   | 0.1~2.25   |
| Head (m)                     | 12~90   | 15~71   | 50~195   | 114~230  |
| Operating sound              | Low   | Low   | Low  | Medium   |
| Installation space           | Very compact  | Compact   | Compact  | Compact  |
| Installation site            | w/outdoor cover   | Indoors only  | Indoors only   | Indoors only   |
| Features                     | Space saving<br>Energy saving<br>Quite<br>Complete pump protection<br>Clean water | Perfect for large facilities<br>Energy saving<br>Quite<br>Complete pump protection<br>Clean water | Perfect for high-rise buildings<br>Energy saving<br>Quite<br>Complete pump protection<br>Clean water | Perfect for skyscrapers<br>Energy saving<br>Quite<br>Complete pump protection<br>Clean water |

● Selection range

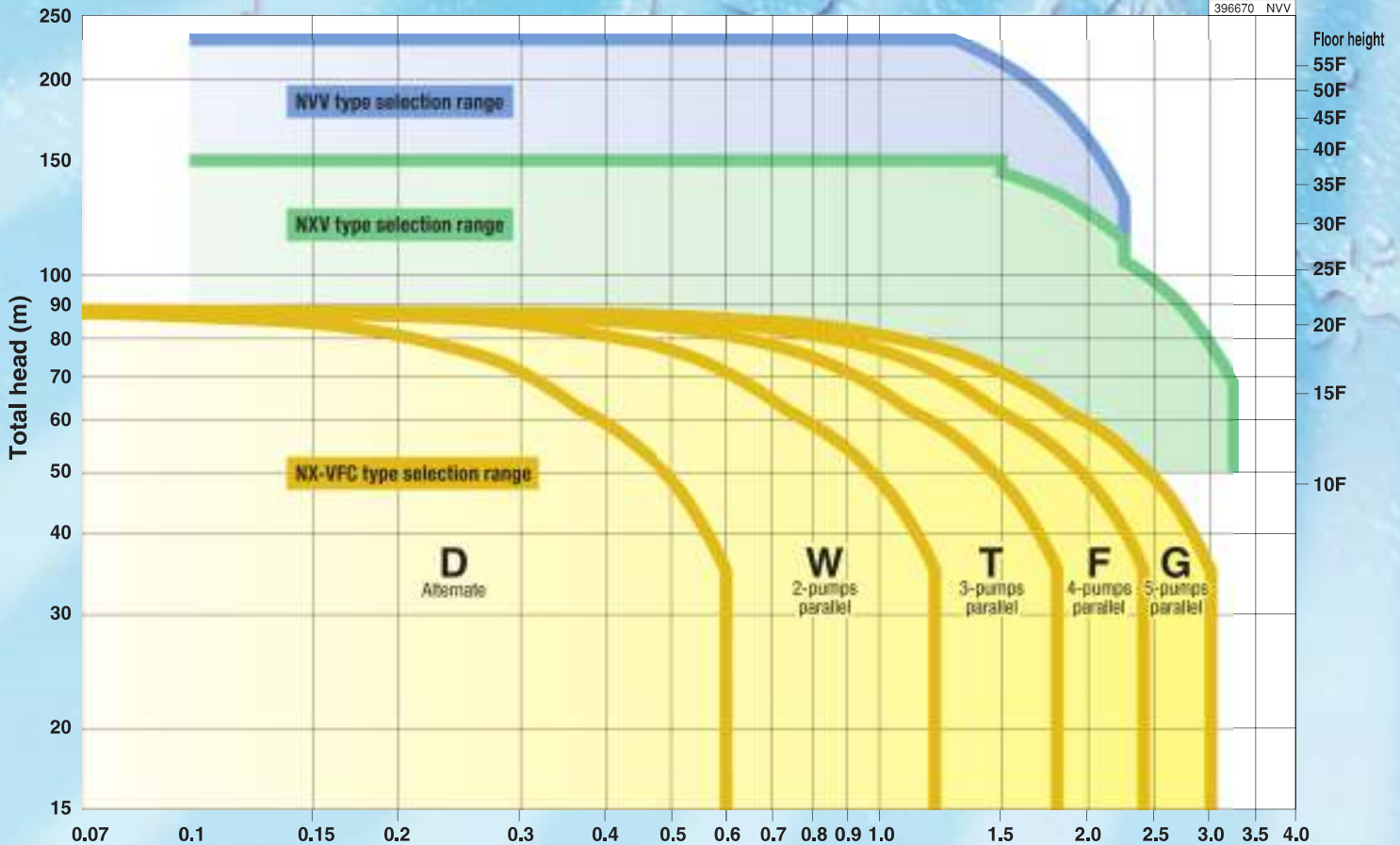

# S U P P L Y S E R I E S

In population centres the life style of the people becomes increasingly diverse, and they put higher demands on the availability of safe water.

When a short term solution is installed, it inevitably leads to high maintenance and running costs.

This catalog introduces the wide range of water supply systems offered by TERAL, Japan's leading water supply systems maker.

Advanced technological power that beats the severe Japanese competition from small home pumps to large volume or high head pumps, providing you with a comfortable and anxiety- and trouble-free future.

|                              | Estimated constant terminal-pressure control  | Constant pressure control   | ON/OFF control   | Small inverter pump   |
|------------------------------|---|---|--|---|
|                              |  |  |  |  |
|                              | Direct connecting Booster pump  | Small type water supply   |  | Domestic Water Supply   |
|                              | <b>MC4</b>  | <b>NX-PCL</b>   | <b>NX-LAT</b>  | <b>THP5-V</b>   |
| Max number of operable pumps | 2   | 2   | 2  | 1   |
| Voltage (V)                  | 3-phase • 200/220   | 3-phase • 380/400/440   | 3-phase • 380/400/440  | Single-phase • 100/200  |
| Output range (kW)            | 0.4~7.5   | 0.4~7.5   | 1.1~7.5  | 0.15~0.75   |
| Flow (m <sup>3</sup> /min)   | 0.015~0.45  | 0.02~1.18   | 0.02~1.2   | 0.019~0.058   |
| Head (m)                     | 25~75   | 11~69   | 12~81  | 12~20   |
| Operating sound              | Low   | Low   | Low  | Low   |
| Installation space           | Very compact  | Very compact  | Very compact   | Very compact  |
| Installation site            | w/outdoor specifications  | w/outdoor cover   | w/outdoor cover  | w/outdoor cover   |
| Features                     | Space saving<br>Energy saving<br>Quiet<br>Complete pump protection<br>Clean water   | Space saving<br>Complete pump protection<br>Clean water                             | Space saving<br>Complete pump protection<br>Clean water                              | Space saving<br>Energy saving<br>Quiet<br>Clean water                                 |

# Today is the age to the estimated constant

Estimated constant terminal-pressure control water supply system

# NX-VFC



## This compact! This high performance!

In 1975, TERAL was the first in the world to unitize a water supply system. Substantial compactness was achieved by integrating the pump, control panel, pressure tank, and base that previously were manufactured separately. Installation space and volume became smaller and the range of applications also spread widely. The use of high quality materials and precision finish increases reliability even more.

**TERAL, the pump maker, has unitized the pump, control panel, pressure tank, and base.**

- >> All parts are high-quality.
- >> Cutting edge functions and performance
- >> Long product life and low maintenance costs



**Can be installed anywhere because of its compact size.**

- >> Can even be installed under a stairs or under the receiving tank.
- >> Replacing an existing pump provides a surplus of machinery room space.
- >> If there is no machinery room, the unit can be installed outdoors by using a special outdoor cover (option).

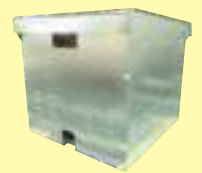

Special outdoor cover (option)

# terminal-pressure control water supply system.

This is the age to the clean, safe, and energy saving estimated constant terminal-pressure control water supply system.

All eyes are on the new TERAL water supply system. With the old elevated water tank system popularized by its simple mechanism and ease of installation, sanitation and construction cost problems are encountered and it can no longer meet the complex and advanced needs of current times. What TERAL proposes here is the <<NX-VFC Series>> estimated terminal pressure constant control water supply unit. This unit eliminates the need for an elevated water tank and also makes a large contribution to electricity and energy saving by using an inverter for exact control of the pump speed.



## Sanitation and construction cost with the conventional elevated water tank system.

This system collects water in an elevated water tank on the roof of the building and supplies it to users by gravity. It is popular because both its mechanism and control are simple. However, the water tank is easily contaminated by birds, insects, and the mixing in of dust. In addition, rooftop installation work is large scale, the piping is 2 systems (up and down) and complex, and the larger the building, the more difficult work becomes.

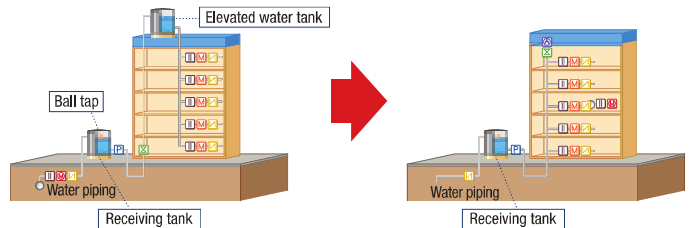

## The mainstream of the future will be a water pressure system that does not require an elevated water tank.

System that supplies water not by gravity, but by pressurizing by pump. A rooftop elevated water tank is unnecessary, and the demerits of the elevated water tank system are all overcome. However, since stopping of the pump immediately leads to water interruption, the introduction of a highly reliable maker who consistently provides everything from design to manufacture is recommended.

## Estimated constant terminal-pressure control system saves energy and eliminates CO<sub>2</sub>!

"Discharge pressure constant control" keeps the discharge pressure constant even if the amount of water used changes by controlling the speed of each pump by means of an inverter. "Estimated constant terminal-pressure control" used with the <<NX-VFC Series>> is more advanced and also adjusts the piping resistance pressure. Since surplus pressure is not generated, electricity and energy saving characteristics are excellent and the electricity consumption is suppressed to approximately 50% that of a conventional system.

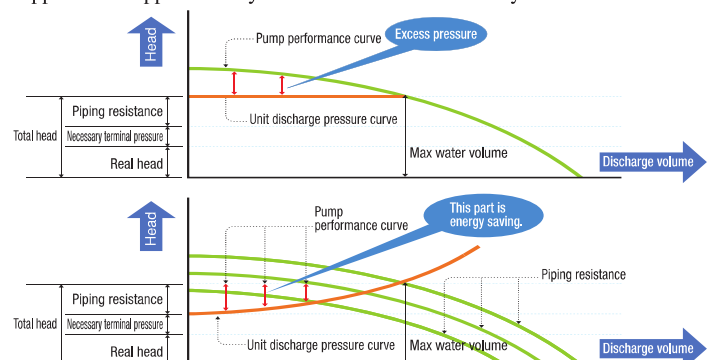

## Unit for trustworthy, clean drinking water.

- >> Pump uses "rust-free" precision stainless steel Investment casting.
- >> All wet parts other than the pump are made of stainless steel, resin, or "rust-free" material.
- >> Leakage-free mechanical seal, resulting in clean and water free surroundings.

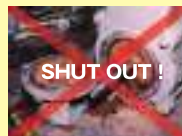

Conventional casting

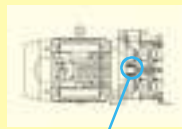

Mechanical seal

# NX-VFC Fully loaded with advance functions

## >> Quiet and ease of installation.

This system is aimed on the future by minimizing the burden on the environment.

**Precision finish contributes to noise reduction.**

As a result of the use of high precision stainless steel forging and pump fluid analysis and design with a 3-dimensional model, the noise generated by the pump has been substantially reduced. In addition, inverter control of pump speed reduces noise during low speed operation still more, thus allowing confident installation even in densely populated areas.

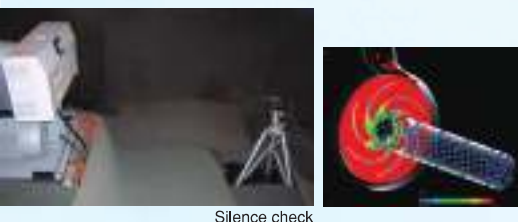

**Inverter control reduces noise and also prevents water hammer.**

The biggest advantage of inverter control is the low noise during starting and stopping. Soft start and stop also prevent water hammer by reducing the sudden pressure applied to the piping.

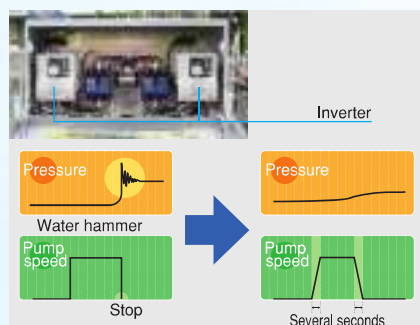

**Complete harmonics countermeasures suppress ambient electromagnetic interference.**

The harmonics generated by the inverter are reduced by various innovative measures and the unit and surrounding devices are protected against burnout. In addition, a radio noise filter is equipped as standard to further suppress ambient electromagnetic interference.

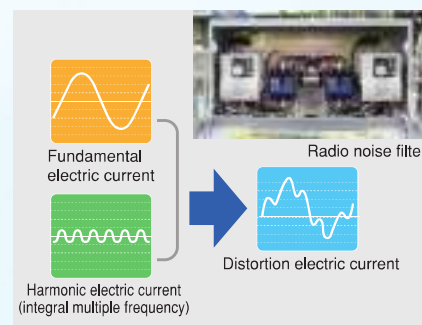

## >> Operability and maintainability.

Easy-to-use interface continually improved by anticipating site needs.

**Easy-to-use, easy-to-read operation panel.**

Pump operating states such as pump operation mode, water tank and solenoid valve operation, various settings can be checked with one glance at the operation panel. Automatic operation can be continued with confidence. Most settings can also be made at the operation panel without opening the control panel cover. Maintenance ease is highly evaluated by maintenance personnel.



**Various alarms and information are displayed on the operation panel.**

Error information is displayed on the operation panel together with generation of a buzzer sound and Caution is raised. Because the error history of the last 5 errors can be called at any time, troublesome referencing of operation recordings is unnecessary. The operating time and accumulated number of time each pump was started, which are the criteria for consumables replacement, can also be displayed and action can be taken before trouble occurs.



**Various innovations make maintenance easy.**

Innovation of the layout of the control panel and its internal control devices make access to the inside of the control panel extremely easy.



that meet the needs of all users.



## >> Advanced control and confidence.

Precision control and complete trouble countermeasures eliminate various operational misgivings.

**Emergency stop, backup operation, and other trouble countermeasures are perfect.**

An interlock function that protects the pump by automatically stopping it when trouble or a disaster occurs is provided. Five different emergency signal transmission patterns are available. The pattern most suitable for the environment and operation can be selected. The system is also equipped with an operation backup function that automatically switches to a standby pump if trouble is detected.

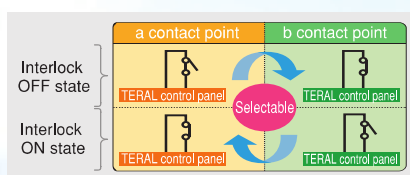

**Retry function recovers from trouble by self-diagnosis.**

The unit is equipped with a retry function that emergency-stops the pump and immediately switches to backup operation

if a trouble is heavy, but repeats restarting and automatically recovers to normal operation if the problem is solved when the trouble is light. Since troubles are handled automatically, there is no inconvenience to the user and maintenance trouble and costs are also substantially reduced.

**Various pump protection functions extend the life of the product.**

A continuous operation prevention function that protects the pump by preventing continuous operation of the pump is provided. In addition, equalizing the operating time of 2 pumps is also possible by operating time equalization function. In addition, the life of the product is extended by racing prevention function that stops

operation beforehand when the water in the tank decreases, etc. and preventing large troubles in advance.

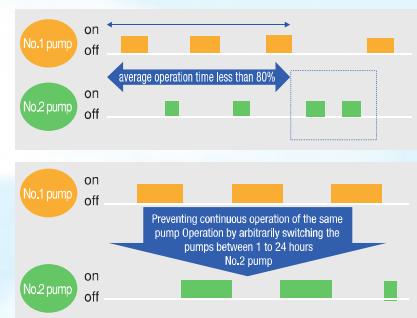

## >> High quality and reliability.

The reliability that can be achieved due to the high quality of the product meets the requirements of the new age.

**Absolute reliability based on severe standards.**

Quality, performance, after-sales service — TERAL has played the role of an industry leader in positive improvement of quality and proposal of official certification standards within Japan. We have received extremely high praise from wary government agencies and consumers of Japan. The TERAL factory has also acquired the international quality management standard ISO9000 and is continuing efforts in quality management and improvement.

**Consistent manufacture and service system with clear responsibilities.**

Even if a system is assembled with a variety of parts, you can hardly ask for more than advanced control. When trouble occurs, determining the cause such as which part has failed or whether or not the control software is faulty is especially difficult. Since the <<NX-VFC Series>> is consistently manufactured and sold by TERAL, the area of responsibility is clear. There is almost no fear of the system stopping and water interruption continuing because the faulty part is quickly located and replaced with a spare based on our abundant experience in maintenance service.



### NX-VFC-D Alternate

#### ▼ Positive suction

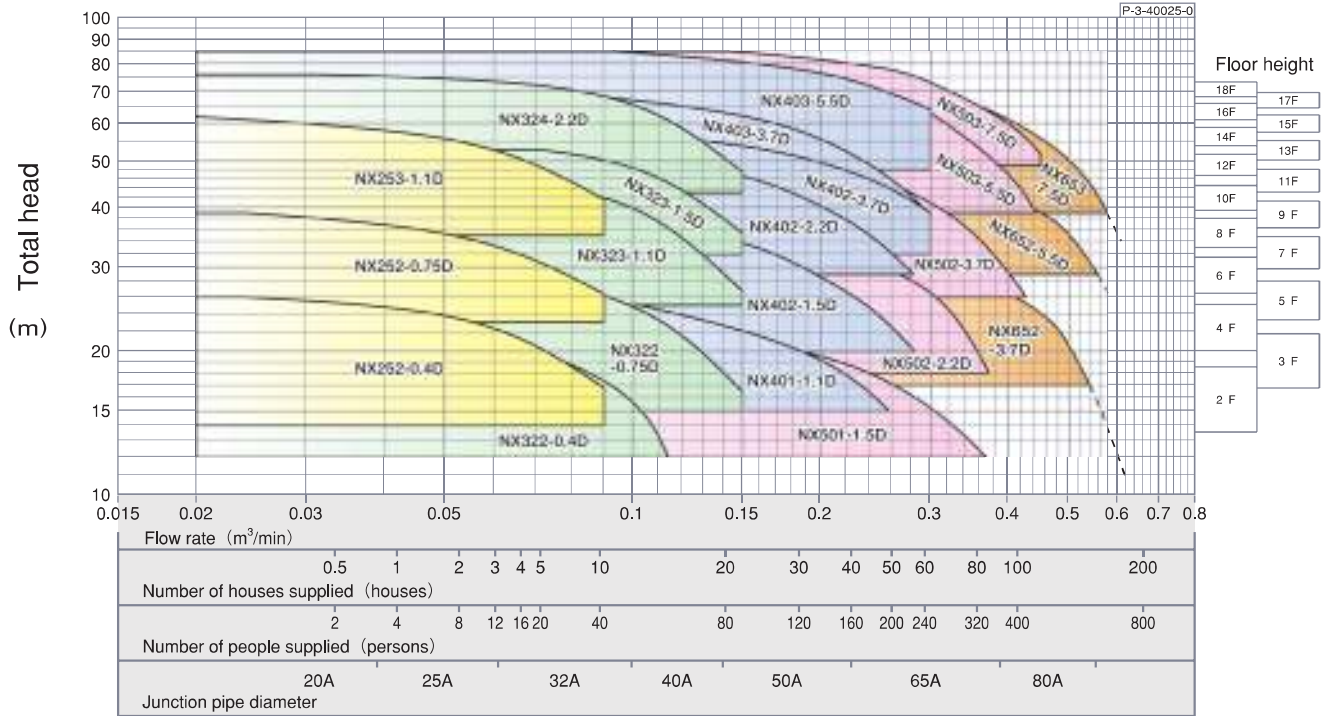

**(Notes)**

- Total head indicates the pump total head when the water level was made the standard instead of the pressure set value.
- When selecting the model from the selection chart, calculate the total head based on the water level.
- The pressure set value (total head and minimum sustained head) is the value with the head from the water level to the pressure transmitter installation position adjusted. (When the water level is lower than the pressure transmitter installation position, only that portion is subtracted and when it is higher, only that portion is added.)

| Suction conditions | Nominal dia. mm |                | Model           | Output kW | Phase and voltage V | Standard specifications            |              |                       |   | Specifications range          |                                  | Pressure tank loading MPa (kgf/m <sup>2</sup> ) |
|--------------------|-----------------|----------------|-----------------|-----------|---------------------|------------------------------------|--------------|-----------------------|---|-------------------------------|----------------------------------|---|
|                    | Pump suction    | Unit discharge |                 |           |                     | Max. flow rate m <sup>3</sup> /min | Total head m | Min. sustained head m | Stop pressure (approximate value) MPa (kgf/m <sup>2</sup> ) | Flow rate m <sup>3</sup> /min | Discharge head selection range m |   |
| Positive suction   | 25              | 25             | NX-VFC252-0.4D  | 0.4       | 3-phase, 380-440    | 0.05                               | 22           | 15                    | 0.24 (2.4)  | 0.02~0.05                     | 14~25                            | 0.12 (1.2)                                      |
|                    |                 |                | NX-VFC252-0.75D | 0.75      |                     | 0.06                               | 33           | 26                    | 0.32 (3.2)  | 0.02~0.05                     | 23~39                            | 0.20 (2.0)                                      |
|                    |                 |                | NX-VFC253-1.1D  | 1.1       |                     | 0.06                               | 52           | 44                    | 0.51 (5.2)  | 0.02~0.05                     | 35~62                            | 0.30 (3.1)                                      |
|                    |                 |                | NX-VFC322-0.4D  | 0.4       |                     | 0.10                               | 15           | 13                    | 0.18 (1.8)  | 0.02~0.11                     | 12~21                            | 0.10 (1.0)                                      |
|                    |                 |                | NX-VFC322-0.75D | 0.75      |                     | 0.10                               | 24           | 20                    | 0.25 (2.5)  | 0.02~0.15                     | 15~26                            | 0.12 (1.2)                                      |
|                    |                 |                | NX-VFC323-1.1D  | 1.1       |                     | 0.10                               | 40           | 34                    | 0.39 (4.0)  | 0.02~0.15                     | 25~42                            | 0.22 (2.2)                                      |
|                    | 32              | 32             | NX-VFC323-1.5D  | 1.5       |                     | 0.10                               | 48           | 41                    | 0.47 (4.8)  | 0.02~0.15                     | 32~53                            | 0.27 (2.8)                                      |
|                    |                 |                | NX-VFC324-2.2D  | 2.2       |                     | 0.10                               | 65           | 55                    | 0.64 (6.5)  | 0.02~0.15                     | 43~76                            | 0.37 (3.8)                                      |
|                    |                 |                | NX-VFC401-1.1D  | 1.1       |                     | 0.20                               | 19           | 16                    | 0.21 (2.1)  | 0.02~0.25                     | 15~26                            | 0.12 (1.2)                                      |
|                    |                 |                | NX-VFC402-1.5D  | 1.5       |                     | 0.20                               | 28           | 24                    | 0.28 (2.8)  | 0.02~0.28                     | 20~34                            | 0.17 (1.7)                                      |
|                    |                 |                | NX-VFC402-2.2D  | 2.2       |                     | 0.20                               | 40           | 34                    | 0.39 (4.0)  | 0.02~0.28                     | 29~48                            | 0.25 (2.5)                                      |
|                    |                 |                | NX-VFC402-3.7D  | 3.7       |                     | 0.20                               | 49           | 42                    | 0.48 (4.9)  | 0.02~0.30                     | 32~57                            | 0.27 (2.8)                                      |
|                    | 40              | 40             | NX-VFC403-3.7D  | 3.7       |                     | 0.20                               | 55           | 47                    | 0.54 (5.5)  | 0.02~0.30                     | 39~70                            | 0.33 (3.4)                                      |
|                    |                 |                | NX-VFC403-5.5D  | 5.5       |                     | 0.20                               | 76           | 65                    | 0.75 (7.6)  | 0.02~0.30                     | 49~85                            | 0.42 (4.3)                                      |
|                    |                 |                | NX-VFC501-1.5D  | 1.5       |                     | 0.30                               | 15           | 13                    | 0.18 (1.8)  | 0.02~0.36                     | 12~20                            | 0.10 (1.0)                                      |
|                    |                 |                | NX-VFC502-2.2D  | 2.2       |                     | 0.30                               | 26           | 22                    | 0.26 (2.7)  | 0.02~0.37                     | 18~31                            | 0.15 (1.5)                                      |
|                    |                 |                | NX-VFC502-3.7D  | 3.7       |                     | 0.30                               | 41           | 35                    | 0.40 (4.1)  | 0.02~0.42                     | 25~47                            | 0.23 (2.3)                                      |
|                    |                 |                | NX-VFC503-5.5D  | 5.5       |                     | 0.30                               | 61           | 52                    | 0.60 (6.1)  | 0.02~0.44                     | 39~64                            | 0.34 (3.5)                                      |
|                    | 50              | 50             | NX-VFC503-7.5D  | 7.5       |                     | 0.30                               | 73           | 62                    | 0.72 (7.3)  | 0.02~0.45                     | 49~85                            | 0.42 (4.3)                                      |
|                    |                 |                | NX-VFC652-3.7D  | 3.7       |                     | 0.45                               | 24           | 20                    | 0.25 (2.5)  | 0.02~0.54                     | 17~31                            | 0.15 (1.5)                                      |
|                    |                 |                | NX-VFC652-5.5D  | 5.5       |                     | 0.45                               | 39           | 33                    | 0.38 (3.9)  | 0.02~0.55                     | 29~48                            | 0.25 (2.5)                                      |
|                    |                 |                | NX-VFC653-7.5D  | 7.5       |                     | 0.45                               | 55           | 47                    | 0.54 (5.5)  | 0.02~0.58                     | 39~64                            | 0.34 (3.5)                                      |

- Note 1) When the water level is more than 5m below the pump inlet, please consult us.  
 Note 2) The pressure tank loading may vary depending on the total discharge head.  
 Note 3) 1kgf/cm<sup>2</sup>=0.098MPa.

#### How to read the selection chart and specifications table

- The total head is displayed by the difference of the unit piping pressure loss subtracted from the pump performance.
- The displayed head shows the case of 0 m push-in head. The value varies depending on the suction side conditions.
- The discharge head specifications range is the settable range of the total head and minimum sustained head.

#### Description of operation (automatic alternate pump operation)

- When water is not used, the pump stops.
- When water is used and the pressure inside the piping drops below the specified pressure, the pump immediately starts.
- Up to maximum flow rate Q2, the speed is controlled by an inverter to match the change of the amount of water used and estimated end pressure fixed control is implemented.
- If the amount of water used decreases and drops below the specified flow rate for operation, the pump stops.
- When water is used again, the pump that previously entered the standby state starts and the same operation as that described above is performed.

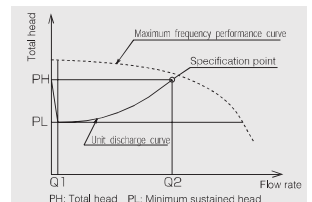



# NX-VFC-W<sub>Parallel</sub>

## ▼ Positive suction

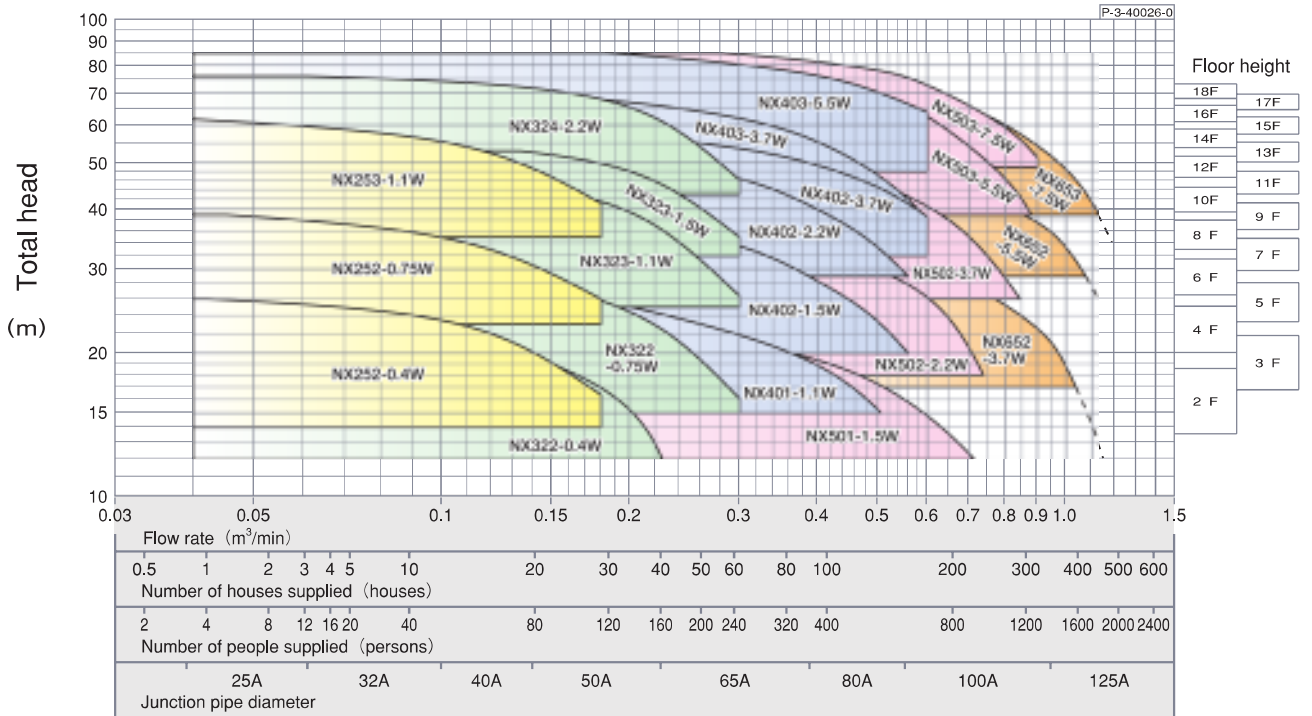

- (Notes)
- Total head indicates the pump total head when the water level was made the standard instead of the pressure set value.
  - When selecting the model from the selection chart, calculate the total head based on the water level.
  - The pressure set value (total head and minimum sustained head) is the value with the head from the water level to the pressure transmitter installation position adjusted.  
(When the water level is lower than the pressure transmitter installation position, only that portion is subtracted and when it is higher, only that portion is added.)

| Suction conditions | Nominal dia. mm |                | Model             | Output kWx2 | Phase and voltage V | Standard specifications            |              |                       |   | Specifications range          |                                  | Pressure tank loading MPA (kgf/m <sup>2</sup> ) |
|--------------------|-----------------|----------------|-------------------|-------------|---------------------|------------------------------------|--------------|-----------------------|---|-------------------------------|----------------------------------|---|
|                    | Pump suction    | Unit discharge |                   |             |                     | Max. flow rate m <sup>3</sup> /min | Total head m | Min. sustained head m | Stop pressure (approximate value) MPA (kgf/m <sup>2</sup> ) | Flow rate m <sup>3</sup> /min | Discharge head selection range m |   |
| Positive suction   | 25              | 40             | NX-40VFC252-0.4W  | 0.4         | 3-phase, 380-440    | 0.12                               | 22           | 19                    | 0.24 (2.4)  | 0.04~0.18                     | 14~26                            | 0.12 (1.2)                                      |
|                    |                 |                | NX-40VFC252-0.75W | 0.75        |                     | 0.12                               | 32           | 27                    | 0.31 (3.2)  | 0.04~0.18                     | 23~39                            | 0.20 (2.0)                                      |
|                    |                 |                | NX-40VFC253-1.1W  | 1.1         |                     | 0.12                               | 52           | 44                    | 0.51 (5.2)  | 0.04~0.18                     | 35~62                            | 0.30 (3.0)                                      |
|                    | 32              | 50             | NX-50VFC322-0.4W  | 0.4         |                     | 0.20                               | 15           | 13                    | 0.18 (1.8)  | 0.04~0.22                     | 12~21                            | 0.10 (1.0)                                      |
|                    |                 |                | NX-50VFC322-0.75W | 0.75        |                     | 0.20                               | 24           | 20                    | 0.25 (2.5)  | 0.04~0.30                     | 15~26                            | 0.12 (1.2)                                      |
|                    |                 |                | NX-50VFC323-1.1W  | 1.1         |                     | 0.20                               | 39           | 33                    | 0.38 (3.9)  | 0.04~0.30                     | 25~42                            | 0.22 (2.2)                                      |
|                    |                 |                | NX-50VFC323-1.5W  | 1.5         |                     | 0.20                               | 48           | 41                    | 0.47 (4.8)  | 0.04~0.30                     | 32~53                            | 0.27 (2.8)                                      |
|                    |                 |                | NX-50VFC324-2.2W  | 2.2         |                     | 0.20                               | 65           | 55                    | 0.64 (6.5)  | 0.04~0.30                     | 43~76                            | 0.37 (3.8)                                      |
|                    |                 |                | NX-50VFC324-2.2W  | 2.2         |                     | 0.40                               | 18           | 15                    | 0.20 (2.0)  | 0.04~0.50                     | 15~26                            | 0.12 (1.2)                                      |
|                    | 40              | 65             | NX-65VFC402-1.5W  | 1.5         |                     | 0.40                               | 28           | 24                    | 0.28 (2.9)  | 0.04~0.56                     | 20~34                            | 0.17 (1.7)                                      |
|                    |                 |                | NX-65VFC402-2.2W  | 2.2         |                     | 0.40                               | 40           | 34                    | 0.39 (4.0)  | 0.04~0.56                     | 29~48                            | 0.25 (2.5)                                      |
|                    |                 |                | NX-65VFC402-3.7W  | 3.7         |                     | 0.40                               | 49           | 42                    | 0.48 (4.9)  | 0.04~0.60                     | 32~57                            | 0.27 (2.8)                                      |
|                    |                 |                | NX-65VFC403-3.7W  | 3.7         |                     | 0.40                               | 55           | 47                    | 0.54 (5.5)  | 0.04~0.60                     | 36~70                            | 0.33 (3.4)                                      |
|                    |                 |                | NX-65VFC403-5.5W  | 5.5         |                     | 0.40                               | 75           | 65                    | 0.75 (7.6)  | 0.04~0.60                     | 48~85                            | 0.42 (4.3)                                      |
|                    |                 |                | NX-65VFC403-5.5W  | 5.5         |                     | 0.60                               | 14           | 12                    | 0.17 (1.7)  | 0.04~0.71                     | 12~20                            | 0.10 (1.0)                                      |
|                    | 50              | 65             | NX-65VFC502-2.2W  | 2.2         |                     | 0.60                               | 26           | 22                    | 0.26 (2.7)  | 0.04~0.73                     | 18~31                            | 0.15 (1.5)                                      |
|                    |                 |                | NX-65VFC502-3.7W  | 3.7         |                     | 0.60                               | 40           | 34                    | 0.39 (4.0)  | 0.04~0.84                     | 26~47                            | 0.23 (2.3)                                      |
|                    |                 |                | NX-65VFC503-5.5W  | 5.5         |                     | 0.60                               | 61           | 52                    | 0.60 (6.1)  | 0.04~0.87                     | 39~64                            | 0.34 (3.5)                                      |
|                    |                 |                | NX-65VFC503-7.5W  | 7.5         |                     | 0.60                               | 73           | 62                    | 0.72 (7.3)  | 0.04~0.90                     | 49~85                            | 0.42 (4.3)                                      |
|                    |                 |                | NX-80VFC652-3.7W  | 3.7         |                     | 0.90                               | 22           | 19                    | 0.24 (2.4)  | 0.04~1.04                     | 17~31                            | 0.15 (1.5)                                      |
|                    |                 |                | NX-80VFC652-5.5W  | 5.5         |                     | 0.90                               | 37           | 31                    | 0.36 (3.7)  | 0.04~1.07                     | 25~48                            | 0.25 (2.5)                                      |
|                    | 65              | 80             | NX-80VFC653-7.5W  | 7.5         |                     | 0.90                               | 54           | 46                    | 0.53 (5.4)  | 0.04~1.12                     | 35~64                            | 0.34 (3.5)                                      |

- Note 1) When the water level is more than 5m below the pump inlet, please consult us.  
 Note 2) The pressure tank loading may vary depending on the total discharge head.  
 Note 3) 1kgf/cm<sup>2</sup>=0.098MPa.



Description of operation (Automatic alternate and parallel pump operation)

- When water is not used, the pump stops.
- When water is used and the pressure in the piping drops below the specified pressure, the pump is immediately started.
- Up to maximum flow rate Q3, the speed is controlled by an inverter to match the change of the amount of water used and estimated end pressure fixed control is implemented.
- When the amount of water used during independent operation increases and reaches parallel flow rate Q2, the pump that is standing by is tracking started and estimated end pressure fixed control is continued.
- When the amount of water used drops below the parallel flow rate Q2 during parallel operation, the pump that was tracking started is stopped.
- When the amount of water used during independent operation drops below the specified flow rate, the pump stops.
- When water is used again, the pump that was previously standing by starts and the same operation as that described above is performed.

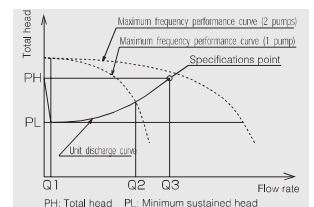

### NX-VFC-D Alternate

#### ▼ Negative suction

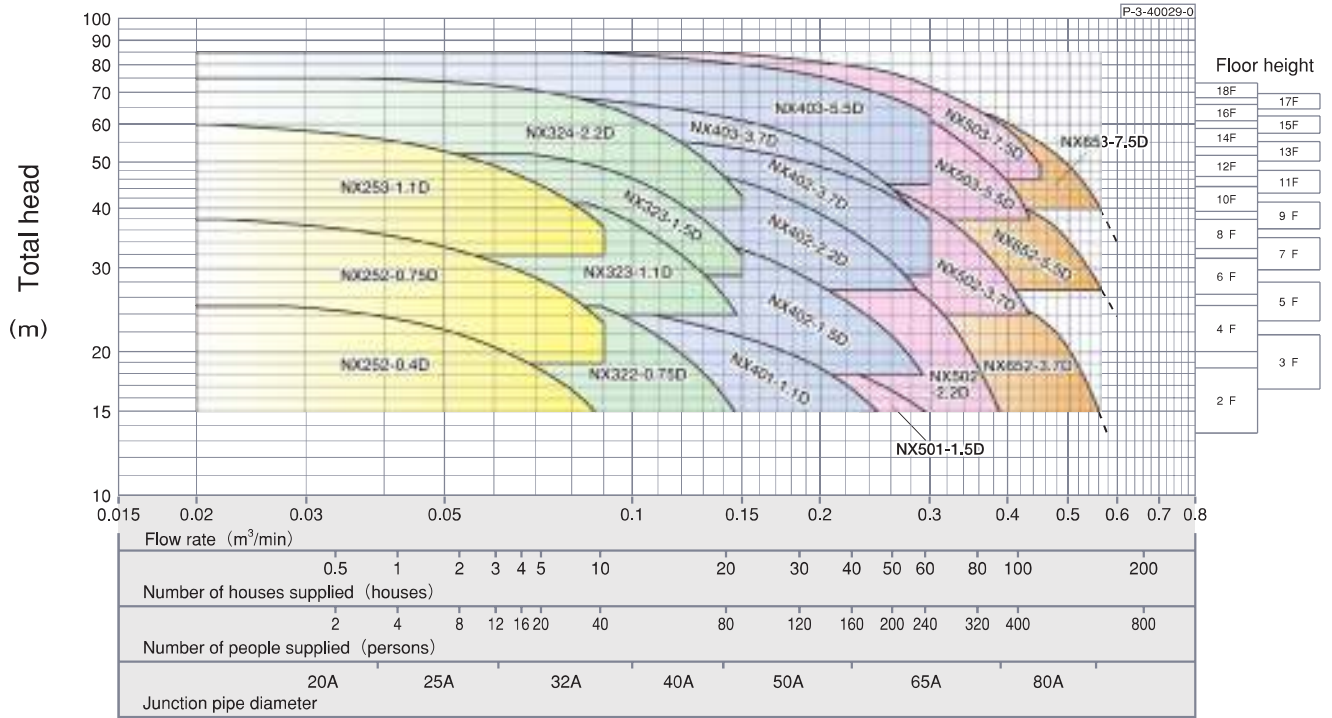

**(Notes)**

- Total head indicates the pump total head when the water level was made the standard instead of the pressure set value.
- When selecting the model from the selection chart, calculate the total head based on the water level.
- The pressure set value (total head and minimum sustained head) is the value with the head from the water level to the pressure transmitter installation position adjusted. (When the water level is lower than the pressure transmitter installation position, only that portion is subtracted and when it is higher, only that portion is added.)

| Suction conditions | Nominal dia. mm |                | Model           | Output kW | Phase and voltage V | Standard specifications            |              |                       |   | Specifications range          |                                  | Pressure tank loading MPA (kgf/m <sup>2</sup> ) |
|--------------------|-----------------|----------------|-----------------|-----------|---------------------|------------------------------------|--------------|-----------------------|---|-------------------------------|----------------------------------|---|
|                    | Pump suction    | Unit discharge |                 |           |                     | Max. flow rate m <sup>3</sup> /min | Total head m | Min. sustained head m | Stop pressure (approximate value) MPa (kgf/m <sup>2</sup> ) | Flow rate m <sup>3</sup> /min | Discharge head selection range m |   |
| Negative suction   | 25              | 25             | NX-VFC252-0.4D  | 0.4       | 3-phase, 380-440    | 0.06                               | 21           | 18                    | 0.23 (2.3)  | 0.02~0.045                    | 15~25                            | 0.06 (0.6)                                      |
|                    |                 |                | NX-VFC252-0.75D | 0.75      |                     | 0.06                               | 31           | 26                    | 0.30 (3.1)  | 0.02~0.09                     | 19~38                            | 0.17 (1.7)                                      |
|                    |                 |                | NX-VFC253-1.1D  | 1.1       |                     | 0.06                               | 52           | 44                    | 0.51 (5.2)  | 0.02~0.09                     | 32~60                            | 0.27 (2.8)                                      |
|                    |                 |                | NX-VFC322-0.75D | 0.75      |                     | 0.10                               | 23           | 20                    | 0.25 (2.5)  | 0.02~0.14                     | 15~25                            | 0.12 (1.2)                                      |
|                    |                 |                | NX-VFC323-1.1D  | 1.1       |                     | 0.10                               | 37           | 31                    | 0.36 (3.7)  | 0.02~0.14                     | 24~41                            | 0.21 (2.1)                                      |
|                    |                 |                | NX-VFC323-1.5D  | 1.5       |                     | 0.10                               | 46           | 39                    | 0.45 (4.5)  | 0.02~0.15                     | 29~52                            | 0.25 (2.5)                                      |
|                    | 32              | 32             | NX-VFC324-2.2D  | 2.2       |                     | 0.10                               | 62           | 53                    | 0.61 (6.2)  | 0.02~0.15                     | 40~75                            | 0.34 (3.5)                                      |
|                    |                 |                | NX-VFC401-1.1D  | 1.1       |                     | 0.20                               | 18           | 15                    | 0.20 (2.0)  | 0.02~0.24                     | 15~25                            | 0.10 (1.0)                                      |
|                    |                 |                | NX-VFC402-1.5D  | 1.5       |                     | 0.20                               | 27           | 23                    | 0.27 (2.8)  | 0.02~0.29                     | 18~34                            | 0.16 (1.6)                                      |
|                    |                 |                | NX-VFC402-2.2D  | 2.2       |                     | 0.20                               | 38           | 32                    | 0.37 (3.8)  | 0.02~0.25                     | 27~48                            | 0.24 (2.4)                                      |
|                    |                 |                | NX-VFC402-3.7D  | 3.7       |                     | 0.20                               | 48           | 41                    | 0.47 (4.8)  | 0.02~0.30                     | 29~57                            | 0.25 (2.5)                                      |
|                    |                 |                | NX-VFC403-3.7D  | 3.7       |                     | 0.20                               | 54           | 46                    | 0.53 (5.4)  | 0.02~0.30                     | 36~70                            | 0.31 (3.2)                                      |
|                    | 40              | 40             | NX-VFC403-5.5D  | 5.5       |                     | 0.20                               | 73           | 62                    | 0.72 (7.3)  | 0.02~0.30                     | 45~85                            | 0.38 (4.0)                                      |
|                    |                 |                | NX-VFC501-1.5D  | 1.5       |                     | 0.29                               | 15           | 13                    | 0.18 (1.8)  | 0.02~0.29                     | 15~20                            | 0.07 (0.7)                                      |
|                    |                 |                | NX-VFC502-2.2D  | 2.2       |                     | 0.30                               | 25           | 21                    | 0.25 (2.5)  | 0.02~0.38                     | 15~31                            | 0.13 (1.3)                                      |
|                    |                 |                | NX-VFC502-3.7D  | 3.7       |                     | 0.30                               | 40           | 34                    | 0.39 (4.0)  | 0.02~0.44                     | 23~47                            | 0.20 (2.0)                                      |
|                    |                 |                | NX-VFC503-5.5D  | 5.5       |                     | 0.30                               | 61           | 52                    | 0.60 (6.1)  | 0.02~0.43                     | 38~64                            | 0.33 (3.4)                                      |
|                    |                 |                | NX-VFC503-7.5D  | 7.5       |                     | 0.30                               | 71           | 60                    | 0.70 (7.1)  | 0.02~0.45                     | 46~85                            | 0.40 (4.1)                                      |
|                    | 65              | 65             | NX-VFC652-3.7D  | 3.7       |                     | 0.45                               | 23           | 20                    | 0.25 (2.5)  | 0.02~0.56                     | 15~31                            | 0.12 (1.2)                                      |
|                    |                 |                | NX-VFC652-5.5D  | 5.5       |                     | 0.45                               | 39           | 33                    | 0.38 (3.9)  | 0.02~0.56                     | 27~47                            | 0.24 (2.4)                                      |
|                    |                 |                | NX-VFC653-7.5D  | 7.5       |                     | 0.45                               | 54           | 46                    | 0.53 (5.4)  | 0.02~0.56                     | 40~63                            | 0.34 (3.5)                                      |

- Note 1) At water temperature 20°C, the suction head becomes total head -6m (actual head -4m).  
 Note 2) The pressure tank loading may vary depending on the total discharge head.  
 Note 3) 1kgf/cm<sup>2</sup>=0.098MPa.

#### How to read the selection chart and specifications table

- The total head is displayed by the difference of the unit piping pressure loss subtracted from the pump performance.
- The displayed head shows the case of 0 m push-in head. The value varies depending on the suction side conditions.
- The discharge head specifications range is the settable range of the total head and minimum sustained head.

#### Description of operation (automatic alternate pump operation)

- When water is not used, the pump stops.
- When water is used and the pressure inside the piping drops below the specified pressure, the pump immediately starts.
- Up to maximum flow rate Q2, the speed is controlled by an inverter to match the change of the amount of water used and estimated end pressure fixed control is implemented.
- If the amount of water used decreases and drops below the specified flow rate for operation, the pump stops.
- When water is used again, the pump that previously entered the standby state starts and the same operation as that described above is performed.

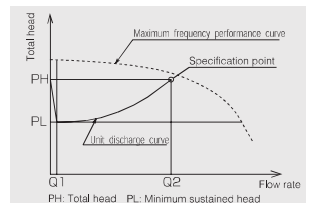

# Selection chart / specifications table < Automatic parallel pump operation Negative suction >

## NX-VFC-W<sub>Parallel</sub>

### ▼ Negative suction

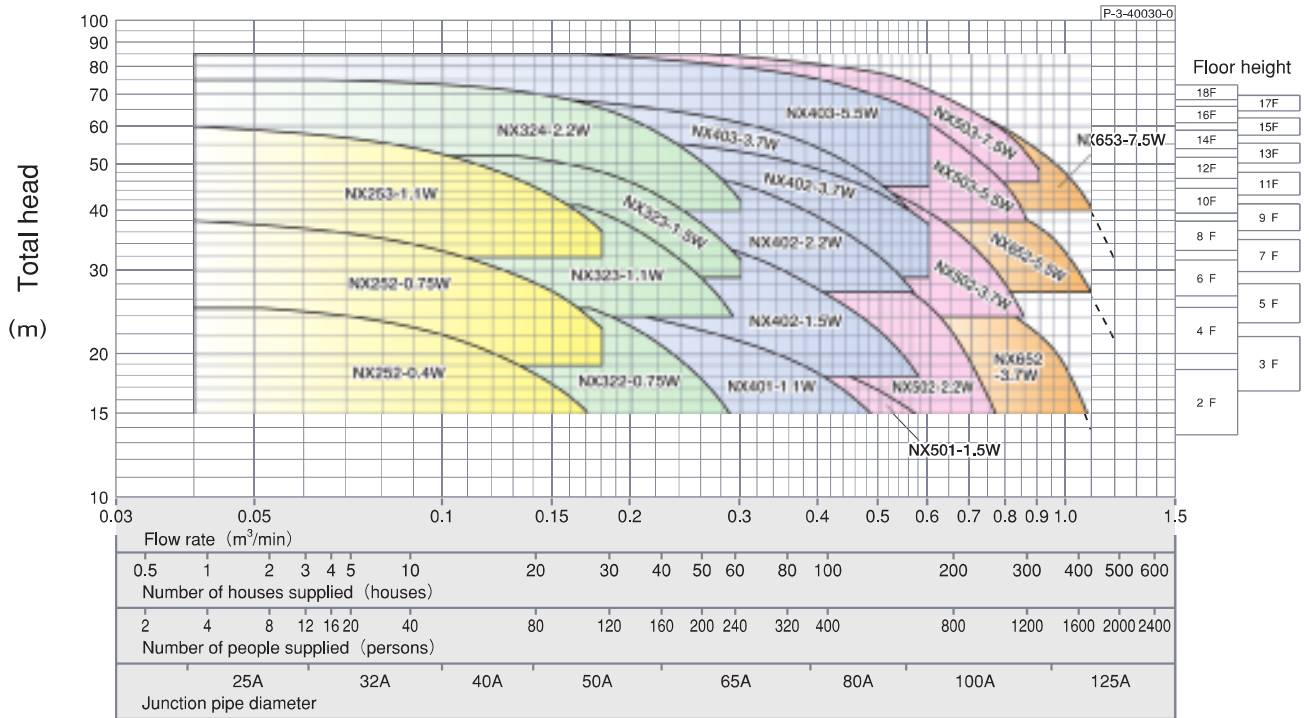

**(Notes)**

- Total head indicates the pump total head when the water level was made the standard instead of the pressure set value.
- When selecting the model from the selection chart, calculate the total head based on the water level.
- The pressure set value (total head and minimum sustained head) is the value with the head from the water level to the pressure transmitter installation position adjusted. (When the water level is lower than the pressure transmitter installation position, only that portion is subtracted and when it is higher, only that portion is added.)

| Suction conditions | Nominal dia. mm |                | Model             | Output kWx2 | Phase and voltage V | Standard specifications            |              |                       |   | Specifications range          |                                  | Pressure tank loading MPa (kgf/m <sup>2</sup> ) |
|--------------------|-----------------|----------------|-------------------|-------------|---------------------|------------------------------------|--------------|-----------------------|---|-------------------------------|----------------------------------|---|
|                    | Pump suction    | Unit discharge |                   |             |                     | Max. flow rate m <sup>3</sup> /min | Total head m | Min. sustained head m | Stop pressure (approximate value) MPa (kgf/m <sup>2</sup> ) | Flow rate m <sup>3</sup> /min | Discharge head selection range m |   |
| Negative suction   | 25              | 40             | NX-40VFC252-0.4W  | 0.4         | 3-phase, 380-440    | 0.12                               | 20           | 17                    | 0.22 (2.2)  | 0.04~0.17                     | 15~25                            | 0.06 (0.6)                                      |
|                    |                 |                | NX-40VFC252-0.75W | 0.75        |                     | 0.12                               | 30           | 26                    | 0.30 (3.1)  | 0.04~0.18                     | 19~38                            | 0.17 (1.7)                                      |
|                    |                 |                | NX-40VFC252-1.1W  | 1.1         |                     | 0.12                               | 48           | 41                    | 0.47 (4.8)  | 0.04~0.18                     | 32~60                            | 0.27 (2.8)                                      |
|                    |                 |                | NX-50VFC322-0.75W | 0.75        |                     | 0.20                               | 23           | 20                    | 0.25 (2.5)  | 0.04~0.28                     | 15~25                            | 0.12 (1.2)                                      |
|                    |                 |                | NX-50VFC322-1.1W  | 1.1         |                     | 0.20                               | 37           | 31                    | 0.36 (3.7)  | 0.04~0.29                     | 24~41                            | 0.21 (2.1)                                      |
|                    |                 |                | NX-50VFC322-1.5W  | 1.5         |                     | 0.20                               | 45           | 38                    | 0.44 (4.5)  | 0.04~0.30                     | 29~52                            | 0.25 (2.5)                                      |
|                    | 32              | 50             | NX-50VFC324-2.2W  | 2.2         |                     | 0.20                               | 62           | 53                    | 0.61 (6.2)  | 0.04~0.30                     | 40~75                            | 0.34 (3.5)                                      |
|                    |                 |                | NX-65VFC401-1.1W  | 1.1         |                     | 0.40                               | 18           | 15                    | 0.20 (2.0)  | 0.04~0.48                     | 15~25                            | 0.10 (1.0)                                      |
|                    |                 |                | NX-65VFC402-1.5W  | 1.5         |                     | 0.40                               | 27           | 23                    | 0.27 (2.8)  | 0.04~0.57                     | 18~34                            | 0.16 (1.6)                                      |
|                    |                 |                | NX-65VFC402-2.2W  | 2.2         |                     | 0.40                               | 38           | 32                    | 0.37 (3.8)  | 0.04~0.56                     | 27~48                            | 0.24 (2.4)                                      |
|                    |                 |                | NX-65VFC402-3.7W  | 3.7         |                     | 0.40                               | 48           | 41                    | 0.47 (4.8)  | 0.04~0.60                     | 29~57                            | 0.25 (2.5)                                      |
|                    |                 |                | NX-65VFC402-5.5W  | 5.5         |                     | 0.40                               | 54           | 46                    | 0.53 (5.4)  | 0.04~0.60                     | 36~70                            | 0.31 (3.2)                                      |
|                    | 40              | 65             | NX-65VFC402-3.7W  | 3.7         |                     | 0.40                               | 73           | 62                    | 0.72 (7.3)  | 0.04~0.60                     | 45~85                            | 0.39 (4.0)                                      |
|                    |                 |                | NX-65VFC501-1.5W  | 1.5         |                     | 0.57                               | 14           | 12                    | 0.17 (1.7)  | 0.04~0.67                     | 15~20                            | 0.07 (0.7)                                      |
|                    |                 |                | NX-65VFC502-2.2W  | 2.2         |                     | 0.60                               | 25           | 21                    | 0.25 (2.5)  | 0.04~0.76                     | 15~31                            | 0.13 (1.3)                                      |
|                    |                 |                | NX-65VFC502-3.7W  | 3.7         |                     | 0.60                               | 39           | 33                    | 0.38 (3.9)  | 0.04~0.85                     | 23~47                            | 0.20 (2.0)                                      |
|                    |                 |                | NX-65VFC503-5.5W  | 5.5         |                     | 0.60                               | 60           | 51                    | 0.59 (6.0)  | 0.04~0.86                     | 38~64                            | 0.33 (3.4)                                      |
|                    |                 |                | NX-65VFC503-7.5W  | 7.5         |                     | 0.60                               | 71           | 60                    | 0.70 (7.1)  | 0.04~0.90                     | 46~85                            | 0.40 (4.1)                                      |
|                    | 65              | 80             | NX-80VFC652-3.7W  | 3.7         |                     | 0.90                               | 22           | 19                    | 0.24 (2.4)  | 0.04~1.06                     | 15~31                            | 0.12 (1.2)                                      |
|                    |                 |                | NX-80VFC652-5.5W  | 5.5         |                     | 0.90                               | 36           | 31                    | 0.35 (3.6)  | 0.04~1.08                     | 27~47                            | 0.24 (2.4)                                      |
|                    |                 |                | NX-80VFC652-7.5W  | 7.5         |                     | 0.90                               | 53           | 45                    | 0.52 (5.3)  | 0.04~1.10                     | 40~63                            | 0.34 (3.5)                                      |

- Note 1) At water temperature 20°C, the suction head becomes total head -6m (actual head -4m).  
 Note 2) The pressure tank loading may vary depending on the total discharge head.  
 Note 3) 1kgf/cm<sup>2</sup>=0.098MPa.

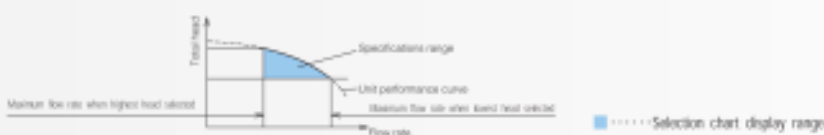

Description of operation (Automatic alternate and parallel pump operation)

- When water is not used, the pump stops.
- When water is used and the pressure in the piping drops below the specified pressure, the pump is immediately started.
- Up to maximum flow rate Q3, the speed is controlled by an inverter to match the change of the amount of water used and estimated end pressure fixed control is implemented.
- When the amount of water used during independent operation increases and reaches parallel flow rate Q2, the pump that is standing by is tracking started and estimated end pressure fixed control is continued.
- When the amount of water used drops below the parallel flow rate Q2 during parallel operation, the pump that was tracking started is stopped.
- When the amount of water used during independent operation drops below the specified flow rate, the pump stops.
- When water is used again, the pump that was previously standing by starts and the same operation as that described above is performed.

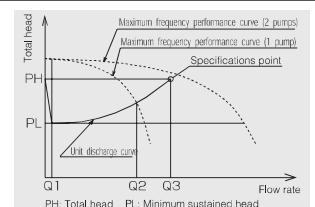

# NX-VFC

## Selection chart < Multiple pump control >

**NX-VFC-Wx3** 2-Pumps Parallel / 3-Pumps Rotation / **Tx3** 3-Pumps Parallel / 3-Pumps Rotation / **Tx4** 3-Pumps Parallel / 4-Pumps Rotation / **Fx4** 4-Pumps Parallel / 4-Pumps Rotation / **Fx5** 4-Pumps Parallel / 5-Pumps Rotation / **Gx5** 5-Pumps Parallel / 5-Pumps Rotation

### ▼ Positive suction

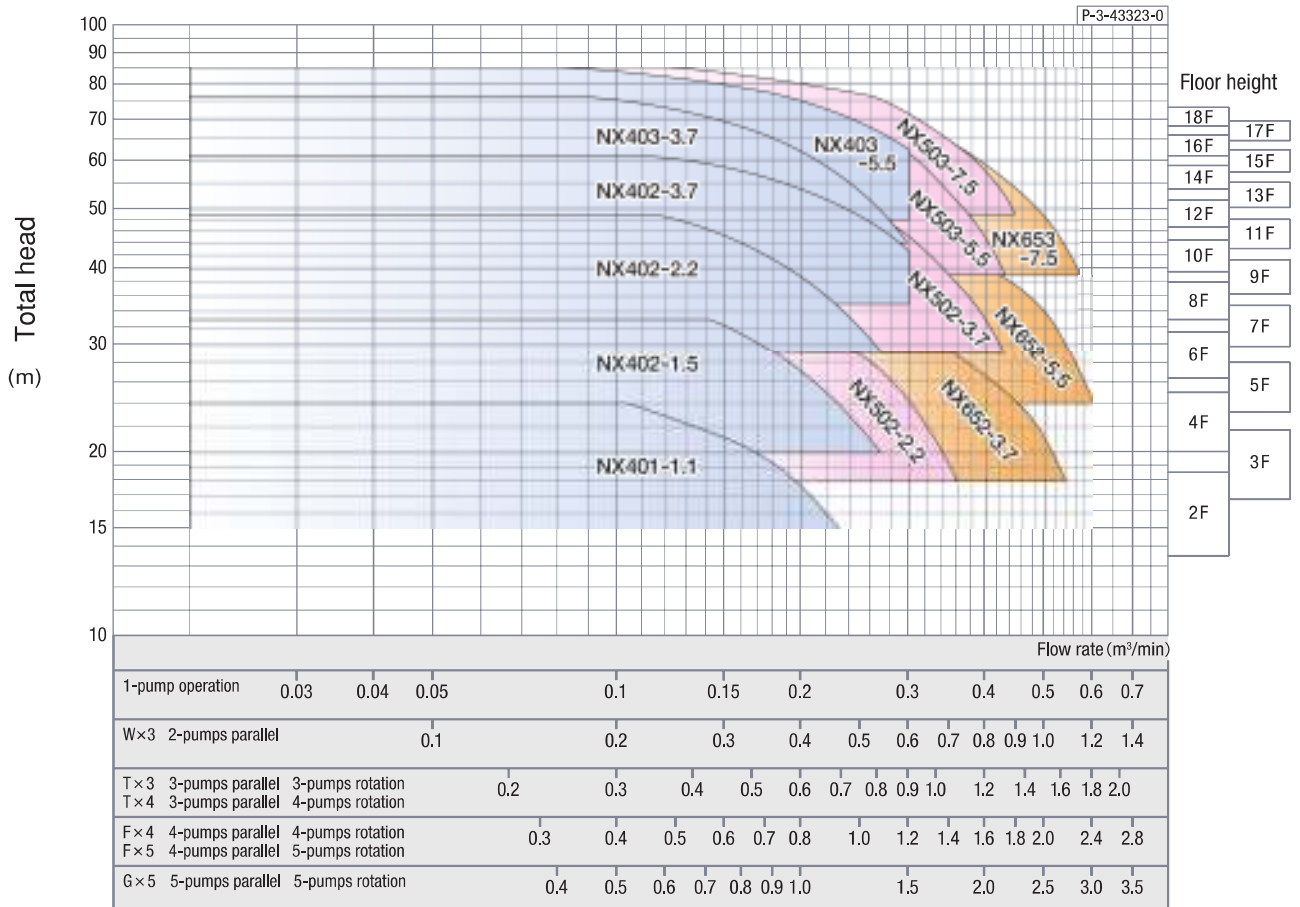

### ▼ Negative Suction

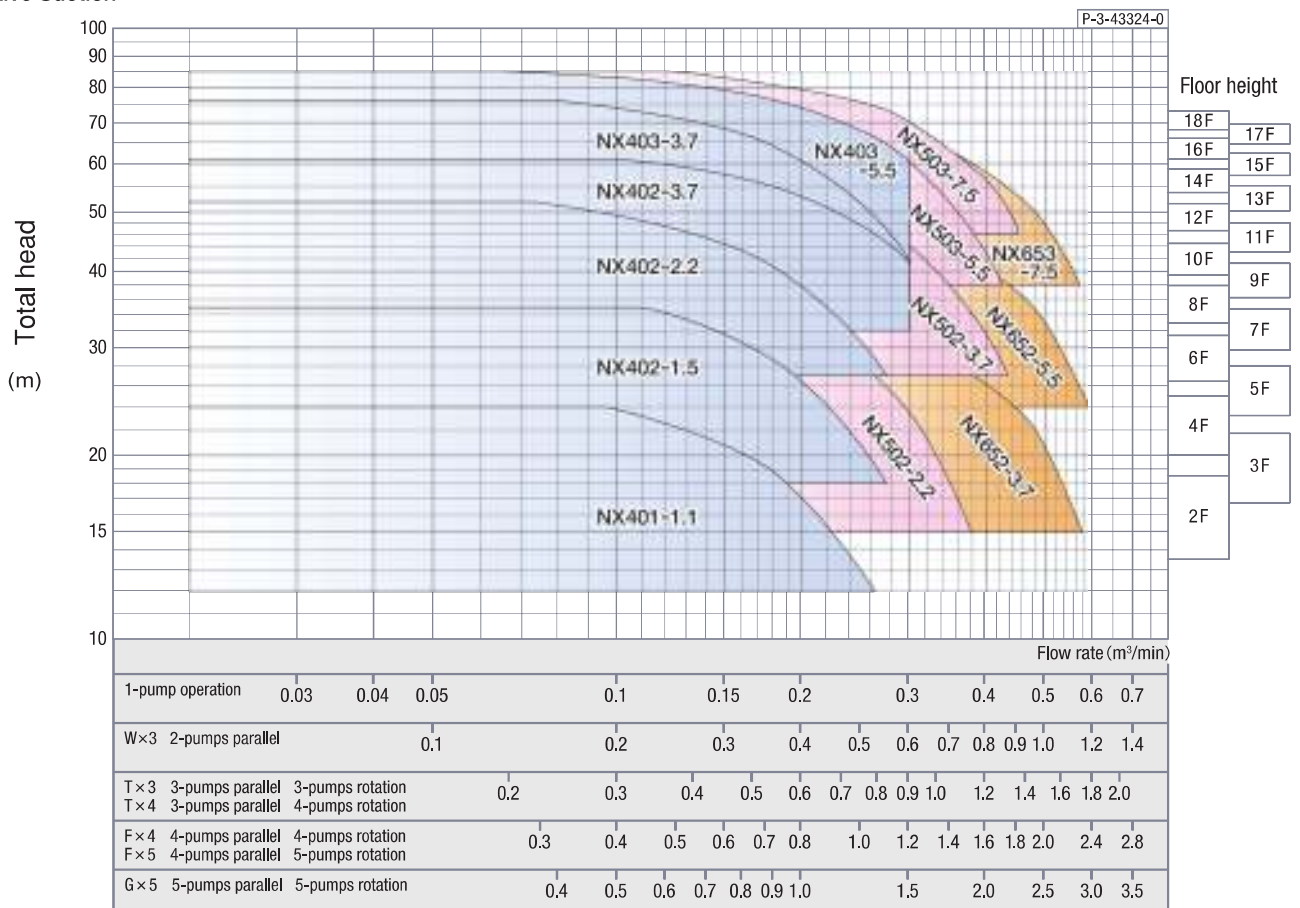

# Specifications table < Multiple pump control >

**NX-VFC-Wx3** 2-Pumps Parallel / 3-Pumps Rotation / **Tx3** 3-Pumps Parallel / 3-Pumps Rotation / **Tx4** 3-Pumps Parallel / 4-Pumps Rotation / **Fx4** 4-Pumps Parallel / 4-Pumps Rotation / **Fx5** 4-Pumps Parallel / 5-Pumps Rotation / **Gx5** 5-Pumps Parallel / 5-Pumps Rotation

## ▼ Positive suction

| Suction condition | Diameter (mm) |                  | Model               | Output (kW)            | Phase and Voltage      | Standard Specifications              |                |                         |                                   | Specified range                 |                                    | Pressure tank loading MPa(kgf/cm <sup>2</sup> ) |           |       |       |       |
|-------------------|---------------|------------------|---------------------|------------------------|------------------------|--------------------------------------|----------------|-------------------------|-----------------------------------|---------------------------------|------------------------------------|---|-----------|-------|-------|-------|
|                   | Pump suction  | Unit discharge   |                     |                        |                        | Max. flow rate (m <sup>3</sup> /min) | Total head (m) | Min. sustained head (m) | Stop pressure (approximate value) | Flow rate (m <sup>3</sup> /min) | Discharge head selection range (m) |   |           |       |       |       |
| Positive suction  | 40            | 65               | 2-Pumps Parallel    | NX-65VFC401-1.1Wx3     | 1.1                    | 3-phase, 380-440                     | 0.4            | 17                      | 14                                | 0.19                            | (1.9)                              | 0.04~0.46                                       | 15~24     | 0.12  | (1.2) |       |
|                   |               |                  |                     | NX-65VFC402-1.5Wx3     | 1.5                    |                                      | 0.4            | 27                      | 23                                | 0.27                            | (2.8)                              | 0.04~0.53                                       | 20~33     | 0.17  | (1.7) |       |
|                   |               |                  |                     | NX-65VFC402-2.2Wx3     | 2.2                    |                                      | 0.4            | 38                      | 32                                | 0.37                            | (3.8)                              | 0.04~0.54                                       | 29~49     | 0.25  | (2.5) |       |
|                   |               |                  |                     | NX-65VFC402-3.7Wx3     | 3.7                    |                                      | 0.4            | 53                      | 45                                | 0.52                            | (5.3)                              | 0.04~0.60                                       | 35~61     | 0.30  | (3.1) |       |
|                   |               |                  |                     | NX-65VFC403-3.7Wx3     | 3.7                    |                                      | 0.4            | 61                      | 52                                | 0.60                            | (6.1)                              | 0.04~0.59                                       | 44~76     | 0.38  | (3.9) |       |
|                   |               |                  |                     | NX-65VFC403-5.5Wx3     | 5.5                    |                                      | 0.4            | 74                      | 63                                | 0.73                            | (7.4)                              | 0.04~0.60                                       | 48~85     | 0.42  | (4.3) |       |
|                   |               | 50               | 80                  | 2-Pumps Parallel       | NX-65VFC502-2.2Wx3     |                                      | 2.2            | 0.6                     | 24                                | 20                              | 0.25                               | (2.5)   | 0.04~0.71 | 18~29 | 0.15  | (1.5) |
|                   |               |                  |                     |                        | NX-65VFC502-3.7Wx3     |                                      | 3.7            | 0.6                     | 45                                | 38                              | 0.44                               | (4.5)   | 0.04~0.85 | 29~47 | 0.25  | (2.5) |
|                   |               |                  |                     |                        | NX-65VFC503-5.5Wx3     |                                      | 5.5            | 0.6                     | 61                                | 52                              | 0.60                               | (6.1)   | 0.04~0.85 | 39~61 | 0.34  | (3.5) |
|                   |               |                  |                     |                        | NX-65VFC503-7.5Wx3     |                                      | 7.5            | 0.6                     | 71                                | 60                              | 0.70                               | (7.1)   | 0.04~0.89 | 49~85 | 0.42  | (4.3) |
|                   |               |                  |                     |                        | NX-80VFC652-3.7Wx3     |                                      | 3.7            | 1.0                     | 21                                | 18                              | 0.23                               | (2.3)   | 0.04~1.08 | 18~29 | 0.15  | (1.5) |
|                   |               |                  |                     |                        | NX-80VFC652-5.5Wx3     |                                      | 5.5            | 1.0                     | 34                                | 29                              | 0.33                               | (3.4)   | 0.04~1.20 | 24~39 | 0.21  | (2.1) |
|                   | 40            | 80               | 3-Pumps Parallel    | NX-80VFC401-1.1Tx3(4)  | 1.1                    |                                      | 0.6            | 17                      | 14                                | 0.19                            | (1.9)                              | 0.06~0.69                                       | 15~24     | 0.12  | (1.2) |       |
|                   |               |                  |                     | NX-80VFC402-1.5Tx3(4)  | 1.5                    |                                      | 0.6            | 27                      | 23                                | 0.27                            | (2.8)                              | 0.06~0.80                                       | 20~33     | 0.17  | (1.7) |       |
|                   |               |                  |                     | NX-80VFC402-2.2Tx3(4)  | 2.2                    |                                      | 0.6            | 38                      | 32                                | 0.37                            | (3.8)                              | 0.06~0.81                                       | 29~49     | 0.25  | (2.5) |       |
|                   |               |                  |                     | NX-80VFC402-3.7Tx3(4)  | 3.7                    |                                      | 0.6            | 53                      | 45                                | 0.52                            | (5.3)                              | 0.06~0.90                                       | 35~61     | 0.30  | (3.1) |       |
|                   |               |                  |                     | NX-80VFC403-3.7Tx3(4)  | 3.7                    |                                      | 0.6            | 61                      | 52                                | 0.60                            | (6.1)                              | 0.06~0.89                                       | 44~76     | 0.38  | (3.9) |       |
|                   |               |                  |                     | NX-80VFC403-5.5Tx3(4)  | 5.5                    |                                      | 0.6            | 74                      | 63                                | 0.73                            | (7.4)                              | 0.06~0.90                                       | 48~85     | 0.42  | (4.3) |       |
|                   |               | 50               | 100                 | 3-Pumps Parallel       | NX-100VFC502-2.2Tx3(4) |                                      | 2.2            | 0.9                     | 24                                | 20                              | 0.25                               | (2.5)   | 0.06~1.07 | 18~29 | 0.15  | (1.5) |
|                   |               |                  |                     |                        | NX-100VFC502-3.7Tx3(4) |                                      | 3.7            | 0.9                     | 45                                | 38                              | 0.44                               | (4.5)   | 0.06~1.28 | 29~47 | 0.25  | (2.5) |
|                   |               |                  |                     |                        | NX-100VFC503-5.5Tx3(4) |                                      | 5.5            | 0.9                     | 61                                | 52                              | 0.60                               | (6.1)   | 0.06~1.29 | 39~61 | 0.34  | (3.5) |
|                   |               |                  |                     |                        | NX-100VFC503-7.5Tx3(4) |                                      | 7.5            | 0.9                     | 71                                | 60                              | 0.70                               | (7.1)   | 0.06~1.33 | 49~85 | 0.42  | (4.3) |
|                   |               |                  |                     |                        | NX-125VFC652-3.7Tx3(4) |                                      | 3.7            | 1.5                     | 21                                | 18                              | 0.23                               | (2.3)   | 0.06~1.62 | 18~29 | 0.15  | (1.5) |
|                   |               |                  |                     |                        | NX-125VFC652-5.5Tx3(4) |                                      | 5.5            | 1.5                     | 34                                | 29                              | 0.33                               | (3.4)   | 0.06~1.80 | 24~39 | 0.21  | (2.1) |
|                   | 40            | 80               | 4-Pumps Parallel    | NX-80VFC401-1.1Fx4(5)  | 1.1                    |                                      | 0.8            | 17                      | 14                                | 0.19                            | (1.9)                              | 0.08~0.92                                       | 15~24     | 0.12  | (1.2) |       |
|                   |               |                  |                     | NX-80VFC402-1.5Fx4(5)  | 1.5                    |                                      | 0.8            | 27                      | 23                                | 0.27                            | (2.8)                              | 0.08~1.07                                       | 20~33     | 0.17  | (1.7) |       |
|                   |               |                  |                     | NX-80VFC402-2.2Fx4(5)  | 2.2                    |                                      | 0.8            | 38                      | 32                                | 0.37                            | (3.8)                              | 0.08~1.08                                       | 29~49     | 0.25  | (2.5) |       |
|                   |               |                  |                     | NX-80VFC402-3.7Fx4(5)  | 3.7                    |                                      | 0.8            | 53                      | 45                                | 0.52                            | (5.3)                              | 0.08~1.20                                       | 35~61     | 0.30  | (3.1) |       |
|                   |               |                  |                     | NX-80VFC403-3.7Fx4(5)  | 3.7                    |                                      | 0.8            | 61                      | 52                                | 0.60                            | (6.1)                              | 0.08~1.19                                       | 44~76     | 0.38  | (3.9) |       |
|                   |               |                  |                     | NX-80VFC403-5.5Fx4(5)  | 5.5                    |                                      | 0.8            | 74                      | 63                                | 0.73                            | (7.4)                              | 0.08~1.20                                       | 48~85     | 0.42  | (4.3) |       |
|                   |               | 50               | 100                 | 4-Pumps Parallel       | NX-100VFC502-2.2Fx4(5) |                                      | 2.2            | 1.2                     | 24                                | 20                              | 0.25                               | (2.5)   | 0.08~1.43 | 18~29 | 0.15  | (1.5) |
|                   |               |                  |                     |                        | NX-100VFC502-3.7Fx4(5) |                                      | 3.7            | 1.2                     | 45                                | 38                              | 0.44                               | (4.5)   | 0.08~1.71 | 29~47 | 0.25  | (2.5) |
|                   |               |                  |                     |                        | NX-100VFC503-5.5Fx4(5) |                                      | 5.5            | 1.2                     | 61                                | 52                              | 0.60                               | (6.1)   | 0.08~1.71 | 39~61 | 0.34  | (3.5) |
|                   |               |                  |                     |                        | NX-100VFC503-7.5Fx4(5) |                                      | 7.5            | 1.2                     | 71                                | 60                              | 0.70                               | (7.1)   | 0.08~1.78 | 49~85 | 0.42  | (4.3) |
|                   |               |                  |                     |                        | NX-125VFC652-3.7Fx4(5) |                                      | 3.7            | 2.0                     | 21                                | 18                              | 0.23                               | (2.3)   | 0.08~2.16 | 18~29 | 0.15  | (1.5) |
|                   |               |                  |                     |                        | NX-125VFC652-5.5Fx4(5) |                                      | 5.5            | 2.0                     | 34                                | 29                              | 0.33                               | (3.4)   | 0.08~2.40 | 24~39 | 0.21  | (2.1) |
|                   | 40            | 100              | 5-Pumps Parallel    | NX-125VFC653-7.5Fx4(5) | 7.5                    |                                      | 2.0            | 48                      | 41                                | 0.47                            | (4.8)                              | 0.08~2.28                                       | 39~64     | 0.34  | (3.5) |       |
|                   |               |                  |                     | NX-100VFC401-1.1Gx5    | 1.1                    |                                      | 1.0            | 17                      | 14                                | 0.19                            | (1.9)                              | 0.1~1.15  | 15~24     | 0.12  | (1.2) |       |
|                   |               |                  |                     | NX-100VFC402-1.5Gx5    | 1.5                    |                                      | 1.0            | 27                      | 23                                | 0.27                            | (2.8)                              | 0.1~1.34  | 20~33     | 0.17  | (1.7) |       |
|                   |               |                  |                     | NX-100VFC402-2.2Gx5    | 2.2                    |                                      | 1.0            | 38                      | 32                                | 0.37                            | (3.8)                              | 0.1~1.35  | 29~49     | 0.25  | (2.5) |       |
|                   |               |                  |                     | NX-100VFC402-3.7Gx5    | 3.7                    |                                      | 1.0            | 53                      | 45                                | 0.52                            | (5.3)                              | 0.1~1.50  | 35~61     | 0.30  | (3.1) |       |
|                   |               |                  |                     | NX-100VFC403-3.7Gx5    | 3.7                    |                                      | 1.0            | 61                      | 52                                | 0.60                            | (6.1)                              | 0.1~1.48  | 44~76     | 0.38  | (3.9) |       |
|                   |               | 50               | 125                 | 5-Pumps Parallel       | NX-100VFC403-5.5Gx5    |                                      | 5.5            | 1.0                     | 74                                | 63                              | 0.73                               | (7.4)   | 0.1~1.50  | 48~85 | 0.42  | (4.3) |
|                   |               |                  |                     |                        | NX-125VFC502-2.2Gx5    |                                      | 2.2            | 1.5                     | 24                                | 20                              | 0.25                               | (2.5)   | 0.1~1.79  | 18~29 | 0.15  | (1.5) |
|                   |               |                  |                     |                        | NX-125VFC502-3.7Gx5    |                                      | 3.7            | 1.5                     | 45                                | 38                              | 0.44                               | (4.5)   | 0.1~2.14  | 29~47 | 0.25  | (2.5) |
|                   |               |                  |                     |                        | NX-125VFC503-5.5Gx5    |                                      | 5.5            | 1.5                     | 61                                | 52                              | 0.60                               | (6.1)   | 0.1~2.14  | 39~61 | 0.34  | (3.5) |
|                   |               |                  |                     |                        | NX-125VFC503-7.5Gx5    |                                      | 7.5            | 1.5                     | 71                                | 60                              | 0.70                               | (7.1)   | 0.1~2.23  | 49~85 | 0.42  | (4.3) |
|                   |               |                  |                     |                        | NX-150VFC652-3.7Gx5    |                                      | 3.7            | 2.5                     | 21                                | 18                              | 0.23                               | (2.3)   | 0.1~2.70  | 18~29 | 0.15  | (1.5) |
| 65                | 150           | 5-Pumps Parallel | NX-150VFC652-5.5Gx5 | 5.5                    | 2.5                    | 34                                   | 29             | 0.33                    | (3.4)                             | 0.1~3.00                        | 24~39                              | 0.21  | (2.1)     |       |       |       |
|                   |               |                  | NX-150VFC653-7.5Gx5 | 7.5                    | 2.5                    | 48                                   | 41             | 0.47                    | (4.8)                             | 0.1~2.85                        | 39~64                              | 0.34  | (3.5)     |       |       |       |

## ▼ Negative Suction

| Suction condition | Diameter (mm) |                | Model            | Output (kW)           | Phase and Voltage      | Standard Specifications              |                |                         |                                   | Specified range                 |                                    | Pressure tank loading MPa(kgf/cm <sup>2</sup> ) |           |       |       |       |
|-------------------|---------------|----------------|------------------|-----------------------|------------------------|--------------------------------------|----------------|-------------------------|-----------------------------------|---------------------------------|------------------------------------|---|-----------|-------|-------|-------|
|                   | Pump suction  | Unit discharge |                  |                       |                        | Max. flow rate (m <sup>3</sup> /min) | Total head (m) | Min. sustained head (m) | Stop pressure (approximate value) | Flow rate (m <sup>3</sup> /min) | Discharge head selection range (m) |   |           |       |       |       |
| Negative Suction  | 40            | 65             | 2-Pumps Parallel | NX-65VFC401-1.1Wx3    | 1.1                    | 3-phase, 380-440                     | 0.4            | 17                      | 14                                | 0.19                            | (1.9)                              | 0.04~0.52                                       | 12~34     | 0.10  | (1.0) |       |
|                   |               |                |                  | NX-65VFC402-1.5Wx3    | 1.5                    |                                      | 0.4            | 26                      | 22                                | 0.26                            | (2.7)                              | 0.04~0.54                                       | 18~35     | 0.16  | (1.6) |       |
|                   |               |                |                  | NX-65VFC402-2.2Wx3    | 2.2                    |                                      | 0.4            | 37                      | 31                                | 0.36                            | (3.7)                              | 0.04~0.54                                       | 27~52     | 0.24  | (2.4) |       |
|                   |               |                |                  | NX-65VFC402-3.7Wx3    | 3.7                    |                                      | 0.4            | 53                      | 45                                | 0.52                            | (5.3)                              | 0.04~0.60                                       | 32~61     | 0.28  | (2.9) |       |
|                   |               |                |                  | NX-65VFC403-3.7Wx3    | 3.7                    |                                      | 0.4            | 60                      | 51                                | 0.59                            | (6.0)                              | 0.04~0.60                                       | 41~76     | 0.35  | (3.6) |       |
|                   |               |                |                  | NX-65VFC403-5.5Wx3    | 5.5                    |                                      | 0.4            | 73                      | 62                                | 0.72                            | (7.3)                              | 0.04~0.60                                       | 41~85     | 0.39  | (4.0) |       |
|                   |               | 50             | 80               | 2-Pumps Parallel      | NX-65VFC502-2.2Wx3     |                                      | 2.2            | 0.6                     | 23                                | 20                              | 0.25                               | (2.5)   | 0.04~0.75 | 15~27 | 0.13  | (1.3) |
|                   |               |                |                  |                       | NX-65VFC502-3.7Wx3     |                                      | 3.7            | 0.6                     | 43                                | 37                              | 0.42                               | (4.3)   | 0.04~0.86 | 27~43 | 0.24  | (2.4) |
|                   |               |                |                  |                       | NX-65VFC503-5.5Wx3     |                                      | 5.5            | 0.6                     | 60                                | 51                              | 0.59                               | (6.0)   | 0.04~0.85 | 38~60 | 0.33  | (3.4) |
|                   |               |                |                  |                       | NX-65VFC503-7.5Wx3     |                                      | 7.5            | 0.6                     | 70                                | 60                              | 0.69                               | (7.0)   | 0.04~0.89 | 46~85 | 0.40  | (4.1) |
|                   |               |                |                  |                       | NX-80VFC652-3.7Wx3     |                                      | 3.7            | 1.0                     | 20                                | 17                              | 0.22                               | (2.2)   | 0.04~1.14 | 15~27 | 0.13  | (1.3) |
|                   |               |                |                  |                       | NX-80VFC652-5.5Wx3     |                                      | 5.5            | 1.0                     | 32                                | 27                              | 0.31                               | (3.2)   | 0.04~1.18 | 24~38 | 0.21  | (2.1) |
|                   | 40            | 80             | 3-Pumps Parallel | NX-80VFC401-1.1Tx3(4) | 1.1                    |                                      | 0.6            | 17                      | 14                                | 0.19                            | (1.9)                              | 0.06~0.79                                       | 12~24     | 0.10  | (1.0) |       |
|                   |               |                |                  | NX-80VFC402-1.5Tx3(4) | 1.5                    |                                      | 0.6            | 26                      | 22                                | 0.26                            | (2.7)                              | 0.06~0.82                                       | 18~35     | 0.16  | (1.6) |       |
|                   |               |                |                  | NX-80VFC402-2.2Tx3(4) | 2.2                    |                                      | 0.6            | 37                      | 31                                | 0.36                            | (3.7)                              | 0.06~0.82                                       | 27~52     | 0.24  | (2.4) |       |
|                   |               |                |                  | NX-80VFC402-3.7Tx3(4) | 3.7                    |                                      | 0.6            | 53                      | 45                                | 0.52                            | (5.3)                              | 0.06~0.90                                       | 32~61     | 0.28  | (2.9) |       |
|                   |               |                |                  | NX-80VFC403-3.7Tx3(4) | 3.7                    |                                      | 0.6            | 60                      | 51                                | 0.59                            | (6.0)                              | 0.06~0.90                                       | 41~76     | 0.35  | (3.6) |       |
|                   |               |                |                  | NX-80VFC403-5.5Tx3(4) | 5.5                    |                                      | 0.6            | 73                      | 62                                | 0.72                            | (7.3)                              | 0.06~0.90                                       | 41~85     | 0.39  | (4.0) |       |
|                   |               | 50             | 100              | 3-Pumps Parallel      | NX-100VFC502-2.2Tx3(4) |                                      | 2.2            | 0.9                     | 23                                | 20                              | 0.25                               | (2.5)   | 0.06~1.13 | 15~27 | 0.13  | (1.3) |
|                   |               |                |                  |                       | NX-100VFC502-3.7Tx3(4) |                                      | 3.7            | 0.9                     | 43                                | 37                              | 0.42                               | (4.3)   | 0.06~1.30 | 27~43 | 0.24  | (2.4) |
|                   |               |                |                  |                       | NX-100VFC503-5.5Tx3(4) |                                      | 5.5            | 0.9                     | 60                                | 51                              | 0.59                               | (6.0)   | 0.06~1.27 | 38~60 | 0.33  | (3.4) |
|                   |               |                |                  |                       | NX-100VFC503-7.5Tx3(4) |                                      | 7.5            | 0.9                     | 70                                | 60                              | 0.69                               | (7.0)   | 0.06~1.35 | 46~85 | 0.40  | (4.1) |
|                   |               |                |                  |                       | NX-125VFC652-3.7Tx3(4) |                                      | 3.7            | 1.5                     | 20                                | 17                              | 0.22                               | (2.2)   | 0.06~1.12 | 15~27 | 0.13  | (1.3) |
|                   |               |                |                  |                       | NX-125VFC652-5.5Tx3(4) |                                      | 5.5            | 1.5                     | 32                                | 27                              | 0.31                               | (3.2)   | 0.06~1.16 | 24~38 | 0.21  | (2.1) |
|                   | 40            | 80             | 4-Pumps Parallel | NX-80VFC401-1.1Fx4(5) | 1.1                    |                                      | 0.8            | 17                      | 14                                | 0.19                            | (1.9)                              | 0.08~1.05                                       | 12~24     | 0.10  | (1.0) |       |
|                   |               |                |                  | NX-80VFC402-1.5Fx4(5) | 1.5                    |                                      | 0.8            | 26                      | 22                                | 0.26                            | (2.7)                              | 0.08~1.10                                       | 18~35     | 0.16  | (1.6) |       |
|                   |               |                |                  | NX-80VFC402-2.2Fx4(5) | 2.2                    |                                      | 0.8            | 37                      | 31                                | 0.36                            | (3.7)                              | 0.08~1.09                                       | 27~52     | 0.24  | (2.4) |       |
|                   |               |                |                  | NX-80VFC402-3.7Fx4(5) | 3.7                    |                                      | 0.8            | 53                      | 45                                | 0.52                            | (5.3)                              | 0.08~1.20                                       | 32~61     | 0.28  | (2.9) |       |
|                   |               |                |                  | NX-80VFC403-3.7Fx4(5) | 3.7                    |                                      | 0.8            | 60                      | 51                                | 0.59                            | (6.0)                              | 0.08~1.20                                       | 41~76     | 0.35  | (3.6) |       |
|                   |               |                |                  | NX-80VFC403-5.5Fx4(5) | 5.5                    |                                      | 0.8            | 73                      | 62                                | 0.72                            | (7.3)                              | 0.08~1.20                                       | 41~85     | 0.39  | (4.0) |       |
|                   |               | 50             | 100              | 4-Pumps Parallel      | NX-100VFC502-2.2Fx4(5) |                                      | 2.2            | 1.2                     | 23                                | 20                              | 0.25                               | (2.5)   | 0.08~1.51 | 15~27 | 0.13  | (1.3) |
|                   |               |                |                  |                       | NX-100VFC502-3.7Fx4(5) |                                      | 3.7            | 1.2                     | 43                                | 37                              | 0.42                               | (4.3)   | 0.08~1.73 | 27~43 | 0.24  | (2.4) |
|                   |               |                |                  |                       | NX-100VFC503-5.5Fx4(5) |                                      | 5.5            | 1.2                     | 60                                | 51                              | 0.59                               | (6.0)   | 0.08~1.70 | 38~60 | 0.33  | (3.4) |
|                   |               |                |                  |                       | NX-100VFC503-7.5Fx4(5) |                                      | 7.5            | 1.2                     | 70                                | 60                              | 0.69                               | (7.0)   | 0.08~1.80 | 46~85 | 0.40  | (4.1) |
|                   |               |                |                  |                       | NX-125VFC652-3.7Fx4(5) |                                      | 3.7            | 2.0                     | 20                                | 17                              | 0.22                               | (2.2)   | 0.08~2.29 | 15~27 | 0.13  | (1.3) |
|                   |               |                |                  |                       | NX-125VFC652-5.5Fx4(5) |                                      | 5.5            | 2.0                     | 32                                | 27                              | 0.31                               | (3.2)   |           |       |       |       |

# NX-VFC

## Dimensional outline drawing

### NX-VFC-D Alternate / W Parallel

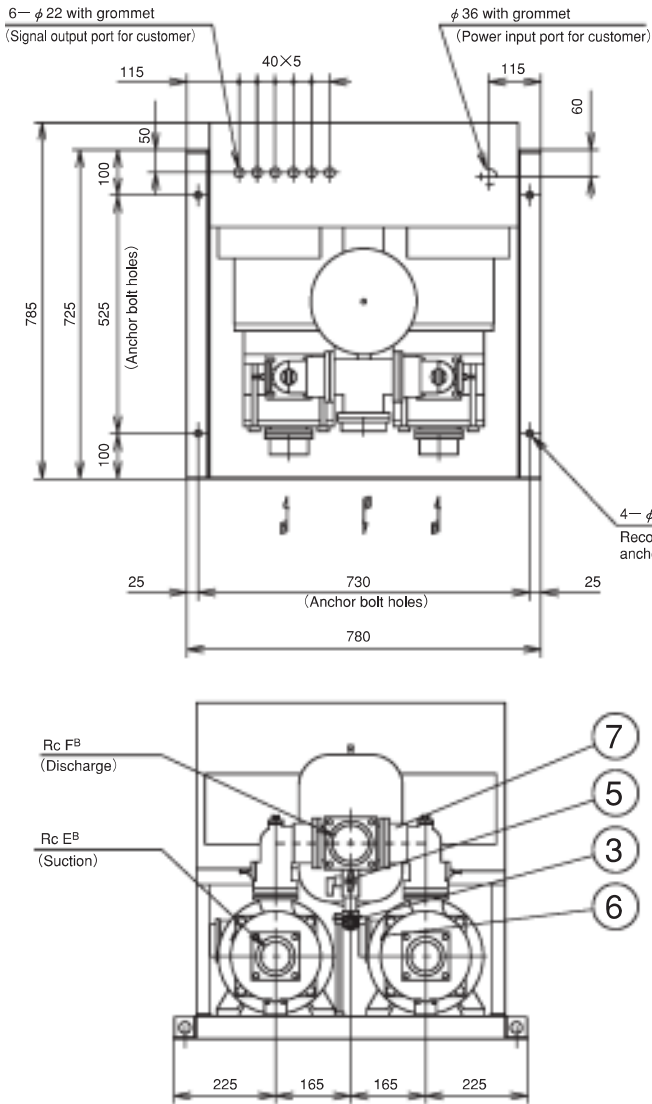

| No | Parts Name              | Q'ty | No | Parts Name   | Q'ty |
|----|-------------------------|------|----|--|------|
| ①  | Pump                    | 2    | ⑦  | Discharge elbow(damping type reverse check valve built-in) | 2    |
| ②  | Pressure tank (10ℓ)     | 1    | ⑧  | Control panel  | 1    |
| ③  | Pressure transmitter    | 1    | ⑨  | Special companion flange (suction)                         | 2    |
| ④  | Flow switch             | 2    | ⑩  | Special companion flange (discharge)                       | 1    |
| ⑤  | TJ valve                | 1    |    |  |      |
| ⑥  | High temperature sensor | 2    |    |  |      |

Negative suction:  
Constant escape piping example

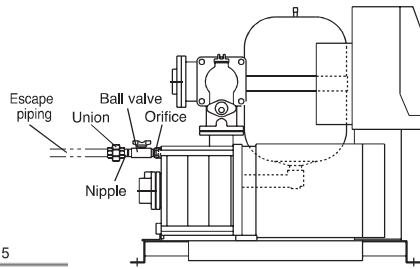

- Pump suction and discharge header connections are special. Several type of companion flanges can be provided with the system.
- Anchor bolts for fixing the pump set are optionally available.
- The system for negative suction includes standard a Constant escape kit. This kit consists of orifice+ball valve+nipple+union. Customer shall provide escape piping, and the end of this pipe shall be always submerged. The ball valve shall be fully opened during operation, such that the flow rate exceeds 10l/min.
- The TJ-valve is suitable to connect dia 10mm (3/8") hose.

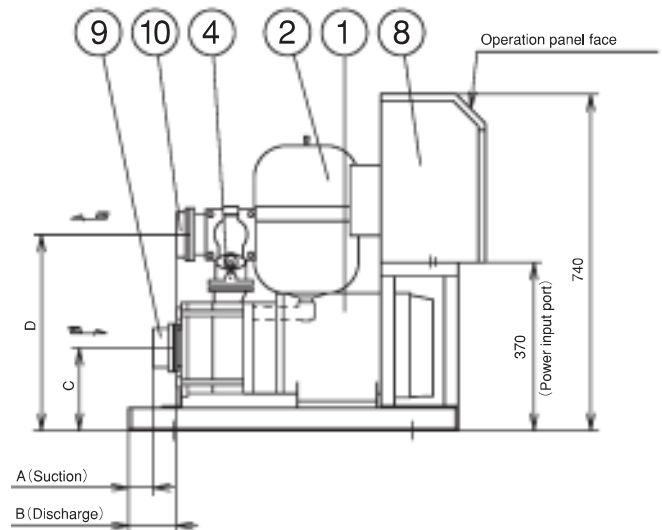

**Caution**

- The drawings are typical, shape may vary somewhat depending on the pump type and specifications.
- Specifications may change due to design modifications. Updated delivery specifications are available upon request.

(Units mm)

| Nominal dia | Suction | Discharge       | Model | A   | B   | C   | D     | E inch | F inch | Approx. weigh kg |
|-------------|---------|-----------------|-------|-----|-----|-----|-------|--------|--------|------------------|
|             |         |                 |       |     |     |     |       |        |        |                  |
|             |         | NX-VFC252-0.75D |       |     |     |     |       |        | 113    |                  |
|             |         | NX-VFC253-1.1D  | 84    |     |     |     |       |        | 121    |                  |
| 32          | 32      | NX-VFC322-0.4D※ | 114   |     |     | 387 |       |        | 104    |                  |
|             |         | NX-VFC322-0.75D |       |     |     |     |       | 112    |        |                  |
|             |         | NX-VFC323-1.1D  | 82    | 131 | 162 |     | 1 1/4 | 1 1/4  | 121    |                  |
|             |         | NX-VFC323-1.5D  |       |     |     |     |       |        | 122    |                  |
|             |         | NX-VFC324-2.2D  | 51    |     |     |     |       | 135    |        |                  |
| 40          | 40      | NX-VFC401-1.1D  | 136   |     |     |     |       |        | 115    |                  |
|             |         | NX-VFC402-1.5D  |       |     |     |     |       | 121    |        |                  |
|             |         | NX-VFC402-2.2D  | 89    | 116 |     | 411 | 1 1/2 | 1 1/2  | 132    |                  |
|             |         | NX-VFC402-3.7D  |       |     |     |     |       |        | 148    |                  |
|             |         | NX-VFC403-3.7D  | 42    |     |     |     |       |        | 154    |                  |
|             |         | NX-VFC403-5.5D  | 42    |     | 182 | 431 |       |        | 194    |                  |
| 50          | 50      | NX-VFC501-1.5D  | 132   |     |     |     |       |        | 116    |                  |
|             |         | NX-VFC502-2.2D  |       |     |     |     |       | 126    |        |                  |
|             |         | NX-VFC502-3.7D  | 85    | 112 | 162 | 411 | 2     | 2      | 148    |                  |
|             |         | NX-VFC503-5.5D  |       |     |     |     |       |        | 195    |                  |
|             |         | NX-VFC503-7.5D  | 38    |     | 182 | 431 |       |        | 199    |                  |
| 65          | 65      | NX-VFC652-3.7D  | 54    |     | 162 | 411 |       |        | 145    |                  |
|             |         | NX-VFC652-5.5D  | 54    | 108 |     |     | 2 1/2 | 2 1/2  | 191    |                  |
|             |         | NX-VFC653-7.5D  | -2    |     | 182 | 431 |       |        | 202    |                  |

※ This model is only for positive suction use.

(Units mm)

| Nominal dia | Suction | Discharge         | Model | A   | B   | C   | D     | E inch | F inch | Approx. weigh kg |
|-------------|---------|-------------------|-------|-----|-----|-----|-------|--------|--------|------------------|
|             |         |                   |       |     |     |     |       |        |        |                  |
|             |         | NX-40VFC252-0.75W |       |     |     |     |       |        | 113    |                  |
|             |         | NX-40VFC253-1.1W  | 84    |     |     |     |       |        | 121    |                  |
| 32          | 50      | NX-50VFC322-0.4W※ | 114   |     |     | 387 |       |        | 104    |                  |
|             |         | NX-50VFC322-0.75W |       |     |     |     |       | 112    |        |                  |
|             |         | NX-50VFC323-1.1W  | 82    | 127 | 162 |     | 1 1/4 | 2      | 121    |                  |
|             |         | NX-50VFC323-1.5W  |       |     |     |     |       |        | 122    |                  |
|             |         | NX-50VFC324-2.2W  | 51    |     |     |     |       | 135    |        |                  |
| 40          | 65      | NX-65VFC401-1.1W  | 136   |     |     |     |       |        | 115    |                  |
|             |         | NX-65VFC402-1.5W  |       |     |     |     |       | 121    |        |                  |
|             |         | NX-65VFC402-2.2W  | 89    |     |     | 411 | 1 1/2 | 2 1/2  | 132    |                  |
|             |         | NX-65VFC402-3.7W  |       |     |     |     |       |        | 148    |                  |
|             |         | NX-65VFC403-3.7W  | 42    |     |     |     |       |        | 154    |                  |
|             |         | NX-65VFC403-5.5W  | 42    | 109 | 182 | 431 |       |        | 194    |                  |
| 50          | 65      | NX-65VFC501-1.5W  | 132   |     |     |     |       |        | 116    |                  |
|             |         | NX-65VFC502-2.2W  |       |     |     |     |       | 126    |        |                  |
|             |         | NX-65VFC502-3.7W  | 85    |     | 162 | 411 | 2     | 2.5    | 148    |                  |
|             |         | NX-65VFC503-5.5W  |       |     |     |     |       |        | 194    |                  |
|             |         | NX-65VFC503-7.5W  | 38    |     | 182 | 431 |       |        | 199    |                  |
| 65          | 80      | NX-80VFC652-3.7W  | 54    |     | 162 | 411 |       |        | 145    |                  |
|             |         | NX-80VFC652-5.5W  | 54    | 105 |     |     | 2 1/2 | 3      | 191    |                  |
|             |         | NX-80VFC653-7.5W  | -2    |     | 182 | 431 |       |        | 202    |                  |

※ This model is only for positive suction use.

# Dimensional outline drawing

## NX-VFC-W×3 2-Pumps Parallel / 3-Pumps Rotation / T×3 3-Pumps Parallel / 3-Pumps Rotation

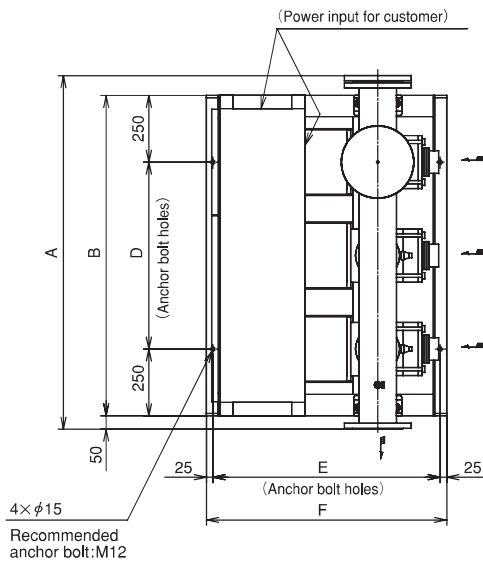

| No | Parts Name              | Q'ty | No | Parts Name                     | Q'ty |
|----|-------------------------|------|----|--------------------------------|------|
| ①  | Pump                    | 3    | ⑦  | Check valve (with flow switch) | 3    |
| ②  | Pressure tank (20ℓ)     | 1    | ⑧  | Stop valve                     | 3    |
| ③  | Pressure transmitter    | 1    | ⑨  | Control panel                  | 1    |
| ④  | Flow switch             | 3    | ⑩  | Special flange (Suction)       | 3    |
| ⑤  | TJ valve                | 1    | ⑪  | Blind Flange                   | 1    |
| ⑥  | High temperature sensor | 3    |    |                                |      |

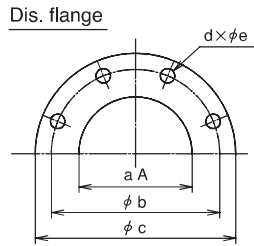

| dis. flange | a   | b   | c   | d | e  |
|-------------|-----|-----|-----|---|----|
| DN65        | 65  | 145 | 185 | 4 | 18 |
| DN80        | 80  | 160 | 200 | 8 | 18 |
| DN100       | 100 | 180 | 220 | 8 | 18 |
| DN125       | 125 | 210 | 250 | 8 | 18 |

### Negative suction: Constant escape piping example

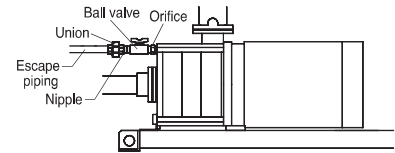

- Pump suction and discharge header connections are special. Several type of companion flanges can be provided with the system.
- Anchor bolts for fixing the pump set are optionally available.
- The system for negative suction includes standard a Constant escape kit. This kit consists of orifice+ball valve+nipple+union. Customer shall provide escape piping, and the end of this pipe shall be always submerged. The ball valve shall be fully opened during operation, such that the flow rate exceeds 10ℓ/min.
- The TJ-valve is suitable to connect dia 10mm (3/8") hose.

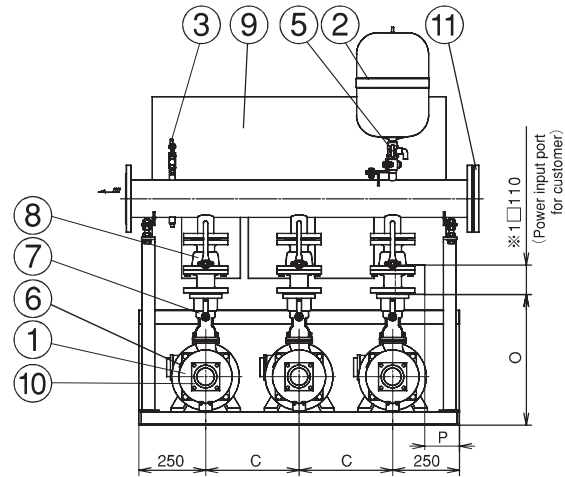
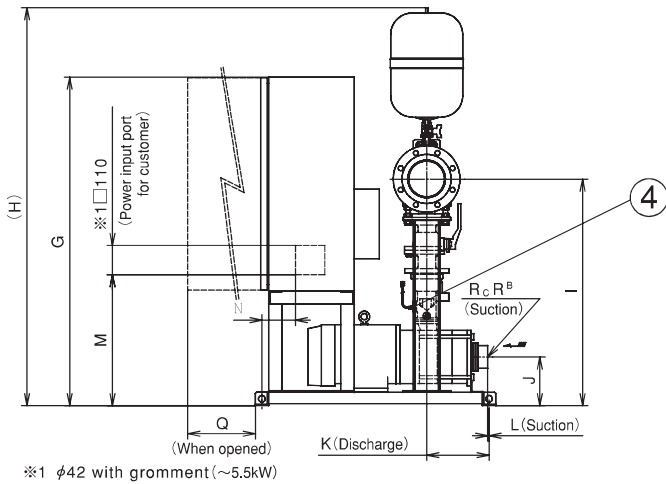

**Caution**

- The drawings are typical, shape may vary somewhat depending on the pump type and specifications.
- Specifications may change due to design modifications. Updated delivery specifications are available upon request.

| Operation mode      | Nominal dia.     |           | Model              | Dimensions (mm)     |      |      |     |     |     |      |      |      |     |       |      |      |     |   |     |     | R inch | Approx. weight kg |  |       |     |     |     |     |     |
|---------------------|------------------|-----------|--------------------|---------------------|------|------|-----|-----|-----|------|------|------|-----|-------|------|------|-----|---|-----|-----|--------|-------------------|--|-------|-----|-----|-----|-----|-----|
|                     | Suction          | Discharge |                    | A                   | B    | C    | D   | E   | F   | G    | H    | I    | J   | K     | L    | M    | N   | O | P   | Q   |        |                   |  |       |     |     |     |     |     |
| 2-Pumps Parallel    | 40               | 65        | NX-65VFC401-1.1W×3 |                     |      |      |     |     |     |      |      |      |     | 111.5 |      |      |     |   |     |     |        |                   |  | 1 1/2 | 339 |     |     |     |     |
|                     |                  |           | NX-65VFC402-1.5W×3 |                     |      |      |     |     |     |      |      |      |     |       |      |      |     |   |     |     |        |                   |  |       |     | 349 |     |     |     |
|                     |                  |           | NX-65VFC402-2.2W×3 | 1122                | 1000 | 250  | 500 | 750 | 800 | 1070 | 1438 | 828  | 162 | 202   | 64.5 | 515  |     |   | 510 | 150 |        |                   |  |       |     | 356 |     |     |     |
|                     |                  |           | NX-65VFC402-3.7W×3 |                     |      |      |     |     |     |      |      |      |     |       |      |      |     |   |     |     |        |                   |  |       |     |     | 381 |     |     |
|                     |                  |           | NX-65VFC403-3.7W×3 |                     |      |      |     |     |     |      |      |      |     |       |      |      |     |   |     |     |        |                   |  |       |     |     | 389 |     |     |
|                     |                  |           | NX-65VFC403-5.5W×3 | 1322                | 1200 | 350  | 700 | 800 | 850 | 1100 | 1458 | 848  | 182 | 233   | 48.5 | 545  |     |   | 540 | 250 |        |                   |  |       |     |     | 445 |     |     |
| 3-Pumps Rotation    | 50               | 65        | NX-65VFC502-2.2W×3 | 1122                | 1000 | 250  | 500 | 750 | 800 | 1070 | 1438 | 828  | 162 | 202   | 60.5 | 515  |     |   | 510 | 150 |        |                   |  |       |     | 356 |     |     |     |
|                     |                  |           | NX-65VFC502-3.7W×3 |                     |      |      |     |     |     |      |      |      |     |       |      |      |     |   |     |     |        |                   |  |       |     |     | 381 |     |     |
|                     |                  |           | NX-65VFC503-5.5W×3 |                     |      |      |     |     |     |      |      |      |     |       |      |      |     |   |     |     |        |                   |  |       |     |     |     | 445 |     |
|                     |                  |           | NX-65VFC503-7.5W×3 | 1322                | 1200 | 350  | 700 | 800 | 850 | 1100 | 1458 | 848  | 182 | 233   | 44.5 | 545  |     |   | 540 | 250 |        |                   |  |       |     |     | 488 |     |     |
|                     |                  |           | NX-80VFC652-3.7W×3 | 1122                | 1000 | 250  | 500 | 750 | 800 | 1070 | 1447 | 828  | 162 | 202   | 30.5 | 515  |     |   | 160 | 510 | 150    |                   |  |       |     |     | 388 |     |     |
|                     |                  |           | NX-80VFC652-5.5W×3 | 1322                | 1200 | 350  | 700 | 800 | 850 | 1100 | 1465 | 848  | 182 | 233   | 61.5 | 545  |     |   | 540 | 250 |        |                   |  |       |     |     | 443 |     |     |
| NX-80VFC653-7.5W×3  |                  |           |                    |                     |      |      |     |     |     |      |      |      |     |       |      |      |     |   |     |     |        |                   |  |       | 495 |     |     |     |     |
| 3-Pumps Parallel    | 40               | 80        | NX-80VFC401-1.1T×3 |                     |      |      |     |     |     |      |      |      |     | 111.5 |      |      |     |   |     |     |        |                   |  |       |     | 342 |     |     |     |
|                     |                  |           | NX-80VFC402-1.5T×3 |                     |      |      |     |     |     |      |      |      |     |       |      |      |     |   |     |     |        |                   |  |       |     |     | 352 |     |     |
|                     |                  |           | NX-80VFC402-2.2T×3 | 1122                | 1000 | 250  | 500 | 750 | 800 | 1070 | 1447 | 828  | 162 | 202   | 64.5 | 515  |     |   | 510 | 150 |        |                   |  |       |     |     | 359 |     |     |
|                     |                  |           | NX-80VFC402-3.7T×3 |                     |      |      |     |     |     |      |      |      |     |       |      |      |     |   |     |     |        |                   |  |       |     |     |     | 384 |     |
|                     |                  |           | NX-80VFC403-3.7T×3 |                     |      |      |     |     |     |      |      |      |     |       |      |      |     |   |     |     |        |                   |  |       |     |     |     | 392 |     |
|                     |                  |           | NX-80VFC403-5.5T×3 | 1322                | 1200 | 350  | 700 | 800 | 850 | 1100 | 1465 | 848  | 182 | 233   | 48.5 | 545  |     |   | 540 | 250 |        |                   |  |       |     |     |     | 447 |     |
|                     | 3-Pumps Rotation | 50        | 100                | NX-100VFC502-2.2T×3 | 1124 | 1000 | 250 | 500 | 750 | 800  | 1070 | 1458 | 828 | 162   | 202  | 60.5 | 515 |   |     | 510 | 150    |                   |  |       |     |     | 365 |     |     |
|                     |                  |           |                    | NX-100VFC502-3.7T×3 |      |      |     |     |     |      |      |      |     |       |      |      |     |   |     |     |        |                   |  |       |     |     |     | 389 |     |
|                     |                  |           |                    | NX-100VFC503-5.5T×3 |      |      |     |     |     |      |      |      |     |       |      |      |     |   |     |     |        |                   |  |       |     |     |     |     | 453 |
|                     |                  |           |                    | NX-100VFC503-7.5T×3 | 1324 | 1200 | 350 | 700 | 800 | 850  | 1100 | 1478 | 848 | 182   | 233  | 44.5 | 545 |   |     | 540 | 250    |                   |  |       |     |     |     | 495 |     |
|                     |                  |           |                    | NX-125VFC652-3.7T×3 | 1124 | 1000 | 250 | 500 | 750 | 800  | 1070 | 1470 | 828 | 162   | 202  | 30.5 | 515 |   |     | 160 | 510    | 150               |  |       |     |     |     | 402 |     |
|                     |                  |           |                    | NX-125VFC652-5.5T×3 | 1324 | 1200 | 350 | 700 | 800 | 850  | 1100 | 1490 | 848 | 182   | 233  | 61.5 | 545 |   |     | 540 | 250    |                   |  |       |     |     |     |     | 458 |
| NX-125VFC653-7.5T×3 |                  |           |                    |                     |      |      |     |     |     |      |      |      |     |       |      |      |     |   |     |     |        |                   |  |       |     | 511 |     |     |     |

# NX-VFC

## Dimensional outline drawing

### NX-VFC-T×4 3-Pumps Parallel / 4-Pumps Rotation / F×4 4-Pumps Parallel / 4-Pumps Rotation

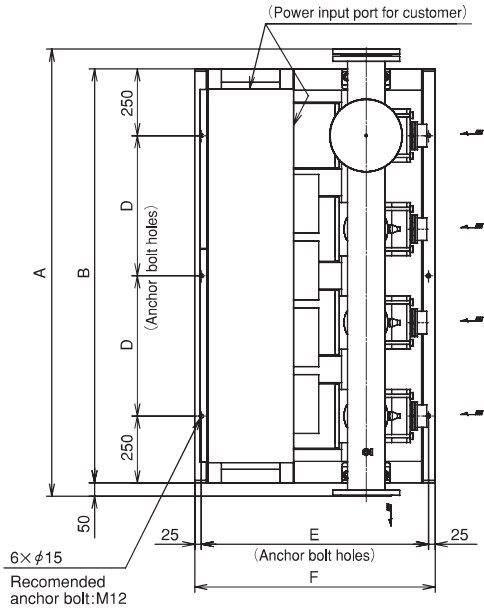

| No | Parts Name              | Q'ty | No | Parts Name                     | Q'ty |
|----|-------------------------|------|----|--------------------------------|------|
| ①  | Pump                    | 4    | ⑦  | Check valve (with flow switch) | 4    |
| ②  | Pressure tank (20ℓ)     | 1    | ⑧  | Stop valve                     | 4    |
| ③  | Pressure transmitter    | 1    | ⑨  | Control panel                  | 1    |
| ④  | Flow switch             | 4    | ⑩  | Special flange (Suction)       | 4    |
| ⑤  | TJ valve                | 1    | ⑪  | Blind Flange                   | 1    |
| ⑥  | High temperature sensor | 4    |    |                                |      |

#### Dis. flange

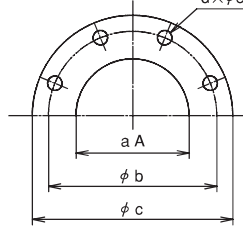

| dis. flange | a   | b   | c   | d | e  |
|-------------|-----|-----|-----|---|----|
| DN80        | 80  | 160 | 200 | 8 | 18 |
| DN100       | 100 | 180 | 220 | 8 | 18 |
| DN125       | 125 | 210 | 250 | 8 | 18 |

#### Negative suction: Constant escape piping example

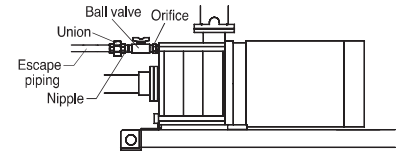

- Since suction flanges of this unit are special, use the companion flange supplied. Discharge flanges are not supplied.
- The TJ valve can connect φ10mm (3/8") hose.
- The anchor bolts are special accessories.
- When negative suction specification is selected, the constant escape kit (orifice + ball valve + nipple + union) is added to the standard specifications. Always provide escape piping and submerge the end of the piping into a water tank. During operation, fully open the ball valve so water escapes to the water tank at a flow rate of 10 l/min or greater.

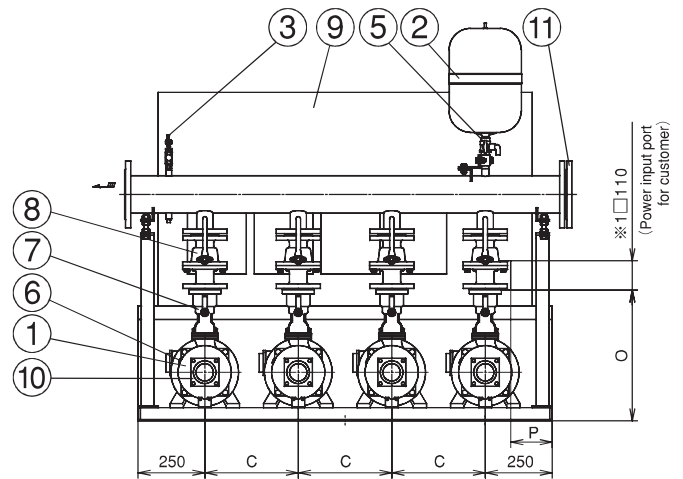
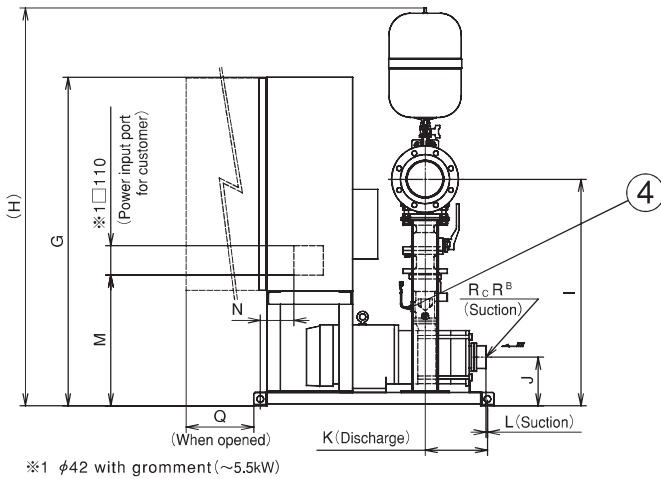

#### Caution

- The drawings are typical, shape may vary somewhat depending on the pump type and specifications.
- Specifications may change due to design modifications. Updated delivery specifications are available upon request.

(Units mm)

| Operation mode                            | Nominal dia. |                     | Model               | A    | B    | C   | D   | E   | F    | G    | H    | I    | J   | K    | L     | M     | N   | O   | P    | Q   | R inch | Approx. weight kg |     |     |     |
|---|--------------|---------------------|---------------------|------|------|-----|-----|-----|------|------|------|------|-----|------|-------|-------|-----|-----|------|-----|--------|-------------------|-----|-----|-----|
|   | Suction      | Discharge           |                     |      |      |     |     |     |      |      |      |      |     |      |       |       |     |     |      |     |        |                   |     |     |     |
| 3-Pumps Parallel<br>•<br>4-Pumps Rotation | 40           | 80                  | NX-80VFC401-1.1T×4  |      |      |     |     |     |      |      |      |      |     |      | 111.5 |       |     |     |      |     |        | 1 1/2             | 426 |     |     |
|   |              |                     | NX-80VFC402-1.5T×4  |      |      |     |     |     |      |      |      |      |     |      |       |       |     |     |      |     |        |                   |     | 440 |     |
|   |              |                     | NX-80VFC402-2.2T×4  | 1372 | 1250 | 250 | 375 | 750 | 800  | 1070 | 1447 | 828  | 162 | 202  | 64.5  | 515   |     |     | 510  | 225 |        |                   |     | 449 |     |
|   |              |                     | NX-80VFC402-3.7T×4  |      |      |     |     |     |      |      |      |      |     |      |       |       |     |     |      |     |        |                   |     | 482 |     |
|   |              |                     | NX-80VFC403-3.7T×4  |      |      |     |     |     |      |      |      |      |     |      |       |       |     |     |      |     |        |                   |     | 493 |     |
|   |              |                     | NX-80VFC403-5.5T×4  | 1672 | 1550 | 350 | 525 | 800 | 850  | 1100 | 1465 | 848  | 182 | 233  | 48.5  | 545   |     |     | 540  | 375 |        |                   |     | 564 |     |
|   | 50           | 100                 | NX-100VFC502-2.2T×4 | 1374 | 1250 | 250 | 375 | 750 | 800  | 1070 | 1458 | 828  | 162 | 202  | 60.5  | 515   |     |     | 510  | 225 |        |                   | 2   | 451 |     |
|   |              |                     | NX-100VFC502-3.7T×4 |      |      |     |     |     |      |      |      |      |     |      |       |       |     |     |      |     |        |                   |     | 483 |     |
|   |              |                     | NX-100VFC503-5.5T×4 |      |      |     |     | 800 | 850  | 1100 |      |      |     |      |       |       |     |     | 540  | 375 |        |                   |     | 569 |     |
|   |              |                     | NX-100VFC503-7.5T×4 | 1674 | 1550 | 350 | 525 |     |      | 850  | 1230 | 1478 | 848 | 182  | 233   | 44.5  | 545 |     |      | 490 | 125    | 490               | 155 | 758 | 618 |
|   |              |                     | NX-125VFC652-3.7T×4 | 1374 | 1250 | 250 | 375 | 750 | 800  | 1070 | 1470 | 828  | 162 | 202  | 30.5  | 515   |     |     | 510  | 255 |        |                   |     | 500 |     |
|   |              |                     | NX-125VFC652-5.5T×4 |      |      |     |     | 800 | 850  | 1100 |      |      |     |      |       |       |     |     | 61.5 | 545 | 160    | 540               | 375 | 558 | 578 |
| 4-Pumps Parallel<br>•<br>4-Pumps Rotation | 40           | 80                  | NX-80VFC401-1.1F×4  |      |      |     |     |     |      |      |      |      |     |      | 111.5 |       |     |     |      |     |        |                   | 426 |     |     |
|   |              |                     | NX-80VFC402-1.5F×4  |      |      |     |     |     |      |      |      |      |     |      |       |       |     |     |      |     |        |                   |     | 440 |     |
|   |              |                     | NX-80VFC402-2.2F×4  | 1372 | 1250 | 250 | 375 | 750 | 800  | 1070 | 1447 | 828  | 162 | 202  | 64.5  | 515   |     |     | 510  | 225 |        |                   |     | 449 |     |
|   |              |                     | NX-80VFC402-3.7F×4  |      |      |     |     |     |      |      |      |      |     |      |       |       |     |     |      |     |        |                   |     | 482 |     |
|   |              |                     | NX-80VFC403-3.7F×4  |      |      |     |     |     |      |      |      |      |     |      |       |       |     |     |      |     |        |                   |     | 493 |     |
|   |              |                     | NX-80VFC403-5.5F×4  | 1672 | 1550 | 350 | 525 | 800 | 850  | 1100 | 1465 | 848  | 182 | 233  | 48.5  | 545   |     |     | 540  | 375 |        |                   |     | 564 |     |
|   | 50           | 100                 | NX-100VFC502-2.2F×4 | 1374 | 1250 | 250 | 375 | 750 | 800  | 1070 | 1458 | 828  | 162 | 202  | 60.5  | 515   |     |     | 510  | 225 |        |                   | 2   | 451 |     |
|   |              |                     | NX-100VFC502-3.7F×4 |      |      |     |     |     |      |      |      |      |     |      |       |       |     |     |      |     |        |                   |     | 483 |     |
|   |              |                     | NX-100VFC503-5.5F×4 |      |      |     |     | 800 | 850  | 1100 |      |      |     |      |       |       |     |     | 540  | 375 |        |                   |     | 569 |     |
|   |              |                     | NX-100VFC503-7.5F×4 | 1674 | 1550 | 350 | 525 |     |      | 850  | 1230 | 1478 | 848 | 182  | 233   | 44.5  | 545 |     |      | 490 | 125    | 490               | 155 | 758 | 618 |
|   |              |                     | NX-125VFC652-3.7F×4 | 1374 | 1250 | 250 | 375 | 750 | 800  | 1070 | 1470 | 828  | 162 | 202  | 30.5  | 515   |     |     | 510  | 225 |        |                   |     | 500 |     |
|   |              |                     | NX-125VFC652-5.5F×4 |      |      |     |     | 800 | 850  | 1100 |      |      |     |      |       |       |     |     | 61.5 | 545 | 160    | 540               | 375 | 558 | 578 |
| 65  | 125          | NX-125VFC653-7.5T×4 | 1674                | 1550 | 350  | 525 |     |     | 850  | 1230 | 1490 | 848  | 182 | 233  | 5.5   | 490   | 125 | 490 | 155  | 758 |        |                   | 640 |     |     |
|   |              | NX-80VFC401-1.1F×4  |                     |      |      |     |     |     |      |      |      |      |     |      |       | 111.5 |     |     |      |     |        |                   | 426 |     |     |
|   |              | NX-80VFC402-1.5F×4  |                     |      |      |     |     |     |      |      |      |      |     |      |       |       |     |     |      |     |        |                   | 440 |     |     |
|   |              | NX-80VFC402-2.2F×4  | 1372                | 1250 | 250  | 375 | 750 | 800 | 1070 | 1447 | 828  | 162  | 202 | 64.5 | 515   |       |     | 510 | 225  |     |        |                   | 449 |     |     |
|   |              | NX-80VFC402-3.7F×4  |                     |      |      |     |     |     |      |      |      |      |     |      |       |       |     |     |      |     |        |                   | 482 |     |     |
|   |              | NX-80VFC403-3.7F×4  |                     |      |      |     |     |     |      |      |      |      |     |      |       |       |     |     |      |     |        |                   | 493 |     |     |



# Dimensional outline drawing

## NX-VFC-Fx5 4-Pumps Parallel / 5-Pumps Rotation / Gx5 5-Pumps Parallel / 5-Pumps Rotation

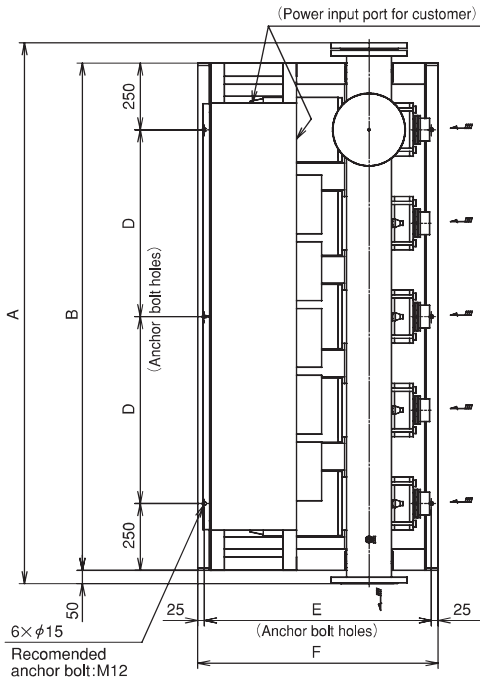

| No | Parts Name              | Q'ty | No | Parts Name                     | Q'ty |
|----|-------------------------|------|----|--------------------------------|------|
| ①  | Pump                    | 5    | ⑦  | Check valve (with flow switch) | 5    |
| ②  | Pressure tank (20ℓ)     | 1    | ⑧  | Stop valve                     | 5    |
| ③  | Pressure transmitter    | 1    | ⑨  | Control panel                  | 1    |
| ④  | Flow switch             | 5    | ⑩  | Special flange (Suction)       | 5    |
| ⑤  | TJ valve                | 1    | ⑪  | Blind Flange                   | 1    |
| ⑥  | High temperature sensor | 5    |    |                                |      |

### Dis. flange

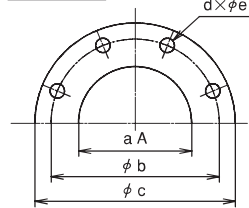

| dis. flange | a   | b   | c   | d | e  |
|-------------|-----|-----|-----|---|----|
| DN80        | 80  | 160 | 200 | 8 | 18 |
| DN100       | 100 | 180 | 220 | 8 | 18 |
| DN125       | 125 | 210 | 250 | 8 | 18 |
| DN150       | 150 | 240 | 285 | 8 | 22 |

### Negative suction: Constant escape piping example

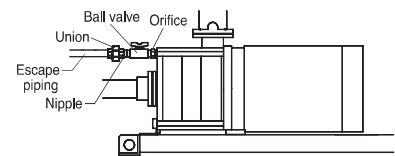

- Since suction flanges of this unit are special, use the companion flange supplied. Discharge flanges are not supplied.
- The TJ valve can connect φ10mm(3/8") hose.
- The anchor bolts are special accessories.
- When negative suction specification is selected, the constant escape kit (orifice + ball valve + nipple + union) is added to the standard specifications. Always provide escape piping and submerge the end of the piping into a water tank. During operation, fully open the ball valve so water escapes to the water tank at a flow rate of 10 l/min or greater.

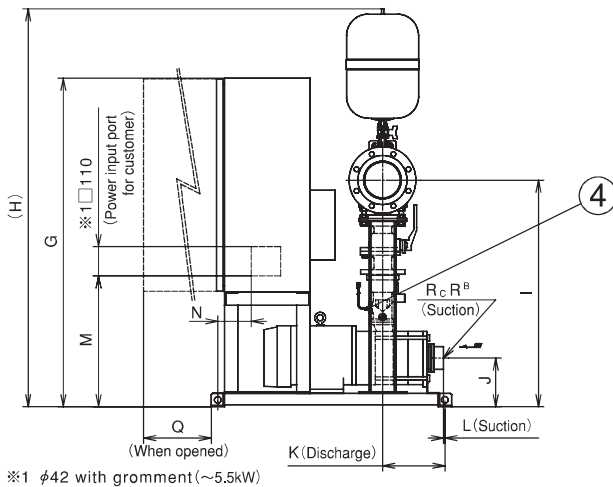

※1 φ42 with grommet (~5.5kW)

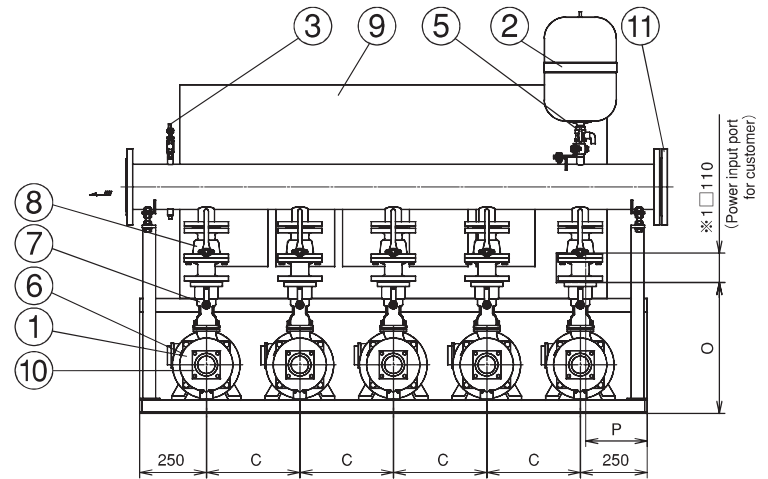

**Caution**

- The drawings are typical, shape may vary somewhat depending on the pump type and specifications.
- Specifications may change due to design modifications. Updated delivery specifications are available upon request.

| Operation mode                            | Nominal dia.                              |           | Model               | A                   | B    | C    | D   | E   | F   | G    | H    | I    | J   | K   | L     | M     | N   | O | P   | Q   | R inch | Approx. weight kg |     |     |     |
|---|---|-----------|---------------------|---------------------|------|------|-----|-----|-----|------|------|------|-----|-----|-------|-------|-----|---|-----|-----|--------|-------------------|-----|-----|-----|
|   | Suction                                   | Discharge |                     |                     |      |      |     |     |     |      |      |      |     |     |       |       |     |   |     |     |        |                   |     |     |     |
| 4-Pumps Parallel<br>•<br>5-Pumps Rotation | 40  | 80        | NX-80VFC401-1.1F×5  |                     |      |      |     |     |     |      |      |      |     |     | 111.5 |       |     |   |     |     | 1 1/2  | 503               |     |     |     |
|   |   |           | NX-80VFC402-1.5F×5  |                     |      |      |     |     |     |      |      |      |     |     |       |       |     |   |     |     |        |                   | 520 |     |     |
|   |   |           | NX-80VFC402-2.2F×5  | 1622                | 1500 | 250  | 500 | 750 | 800 | 1070 | 1447 | 828  | 162 | 202 | 64.5  | 515   |     |   | 510 | 250 |        |                   |     | 531 |     |
|   |   |           | NX-80VFC402-3.7F×5  |                     |      |      |     |     |     |      |      |      |     |     |       |       |     |   |     |     |        |                   |     | 573 |     |
|   |   |           | NX-80VFC403-3.7F×5  |                     |      |      |     |     |     |      |      |      |     |     |       |       |     |   |     |     |        |                   |     | 586 |     |
|   | 5-Pumps Rotation                          | 50        | 100                 | NX-80VFC403-3.7F×5  |      |      |     |     |     |      |      |      |     |     |       |       |     |   |     |     |        |                   |     | 678 |     |
|   |   |           |                     | NX-80VFC403-5.5F×5  | 2022 | 1900 | 350 | 700 | 800 | 850  | 1100 | 1465 | 848 | 182 | 233   | 48.5  | 545 |   |     | 540 | 450    |                   |     |     | 537 |
|   |   |           |                     | NX-100VFC502-2.2F×5 | 1624 | 1500 | 250 | 500 | 750 | 800  | 1070 | 1458 | 828 | 162 | 202   | 60.5  | 515 |   |     | 510 | 250    |                   |     |     | 578 |
|   |   |           |                     | NX-100VFC502-3.7F×5 |      |      |     |     |     |      |      |      |     |     |       |       |     |   |     |     |        |                   |     |     | 685 |
|   |   |           |                     | NX-100VFC503-5.5F×5 | 2024 | 1900 | 350 | 700 | 800 | 850  | 1100 | 1478 | 848 | 182 | 233   | 44.5  | 545 |   |     | 540 | 450    |                   |     |     | 749 |
| 5-Pumps Parallel<br>•<br>5-Pumps Rotation | 40  | 100       | NX-100VFC503-7.5F×5 |                     |      |      |     |     |     |      |      |      |     |     |       |       |     |   |     |     |        |                   | 769 |     |     |
|   |   |           | NX-125VFC652-3.7F×5 | 1624                | 1500 | 250  | 500 | 750 | 800 | 1070 | 1470 | 828  | 162 | 202 | 30.5  | 515   |     |   | 510 | 250 |        |                   |     | 597 |     |
|   |   |           | NX-125VFC652-5.5F×5 | 2024                | 1900 | 350  | 700 | 800 | 850 | 1100 | 1490 | 848  | 182 | 233 | 61.5  | 545   |     |   | 540 | 450 |        |                   |     | 689 |     |
|   |   |           | NX-125VFC653-7.5F×5 |                     |      |      |     |     |     |      |      |      |     |     |       |       |     |   |     |     |        |                   |     | 769 |     |
|   |   |           | NX-125VFC653-7.5F×5 |                     |      |      |     |     |     |      |      |      |     |     |       |       |     |   |     |     |        |                   |     |     | 769 |
|   | 5-Pumps Parallel<br>•<br>5-Pumps Rotation | 50        | 125                 | NX-100VFC401-1.1G×5 |      |      |     |     |     |      |      |      |     |     |       | 111.5 |     |   |     |     |        |                   |     | 508 |     |
|   |   |           |                     | NX-100VFC402-1.5G×5 |      |      |     |     |     |      |      |      |     |     |       |       |     |   |     |     |        |                   |     |     | 525 |
|   |   |           |                     | NX-100VFC402-2.2G×5 | 1622 | 1500 | 250 | 500 | 750 | 800  | 1070 | 1458 | 828 | 162 | 202   | 64.5  | 515 |   |     | 510 | 250    |                   |     |     | 536 |
|   |   |           |                     | NX-100VFC402-3.7G×5 |      |      |     |     |     |      |      |      |     |     |       |       |     |   |     |     |        |                   |     |     | 578 |
|   |   |           |                     | NX-100VFC403-3.7G×5 |      |      |     |     |     |      |      |      |     |     |       |       |     |   |     |     |        |                   |     |     |     |
| 5-Pumps Parallel<br>•<br>5-Pumps Rotation | 65  | 150       | NX-100VFC403-3.7G×5 |                     |      |      |     |     |     |      |      |      |     |     |       |       |     |   |     |     |        |                   | 684 |     |     |
|   |   |           | NX-100VFC403-5.5G×5 | 2022                | 1900 | 350  | 700 | 800 | 850 | 1100 | 1478 | 848  | 182 | 233 | 48.5  | 545   |     |   | 540 | 450 |        |                   |     | 684 |     |
|   |   |           | NX-125VFC502-2.2G×5 | 1624                | 1500 | 250  | 500 | 750 | 800 | 1070 | 1470 | 828  | 162 | 202 | 60.5  | 515   |     |   | 510 | 250 |        |                   |     | 549 |     |
|   |   |           | NX-125VFC502-3.7G×5 |                     |      |      |     |     |     |      |      |      |     |     |       |       |     |   |     |     |        |                   |     |     | 589 |
|   |   |           | NX-125VFC503-5.5G×5 | 2024                | 1900 | 350  | 700 | 800 | 850 | 1100 | 1490 | 848  | 182 | 233 | 44.5  | 545   |     |   | 540 | 450 |        |                   |     | 697 |     |
| 5-Pumps Parallel<br>•<br>5-Pumps Rotation | 65  | 150       | NX-125VFC503-7.5G×5 |                     |      |      |     |     |     |      |      |      |     |     |       |       |     |   |     |     |        |                   | 760 |     |     |
|   |   |           | NX-150VFC652-3.7G×5 | 1626                | 1500 | 250  | 500 | 750 | 800 | 1070 | 1484 | 828  | 162 | 202 | 30.5  | 515   |     |   | 510 | 250 |        |                   |     | 606 |     |
|   |   |           | NX-150VFC652-5.5G×5 | 2026                | 1900 | 350  | 700 | 800 | 850 | 1100 | 1504 | 848  | 182 | 233 | 61.5  | 545   |     |   | 540 | 450 |        |                   |     | 701 |     |
|   |   |           | NX-150VFC653-7.5G×5 |                     |      |      |     |     |     |      |      |      |     |     |       |       |     |   |     |     |        |                   |     |     | 780 |
|   |   |           | NX-150VFC653-7.5G×5 |                     |      |      |     |     |     |      |      |      |     |     |       |       |     |   |     |     |        |                   |     |     | 780 |

(Units mm)

## Water supply unit connection diagram (ex. D/W type, Positive suction)

[Caution] For installation-related design and installation, please refer to the drawings.

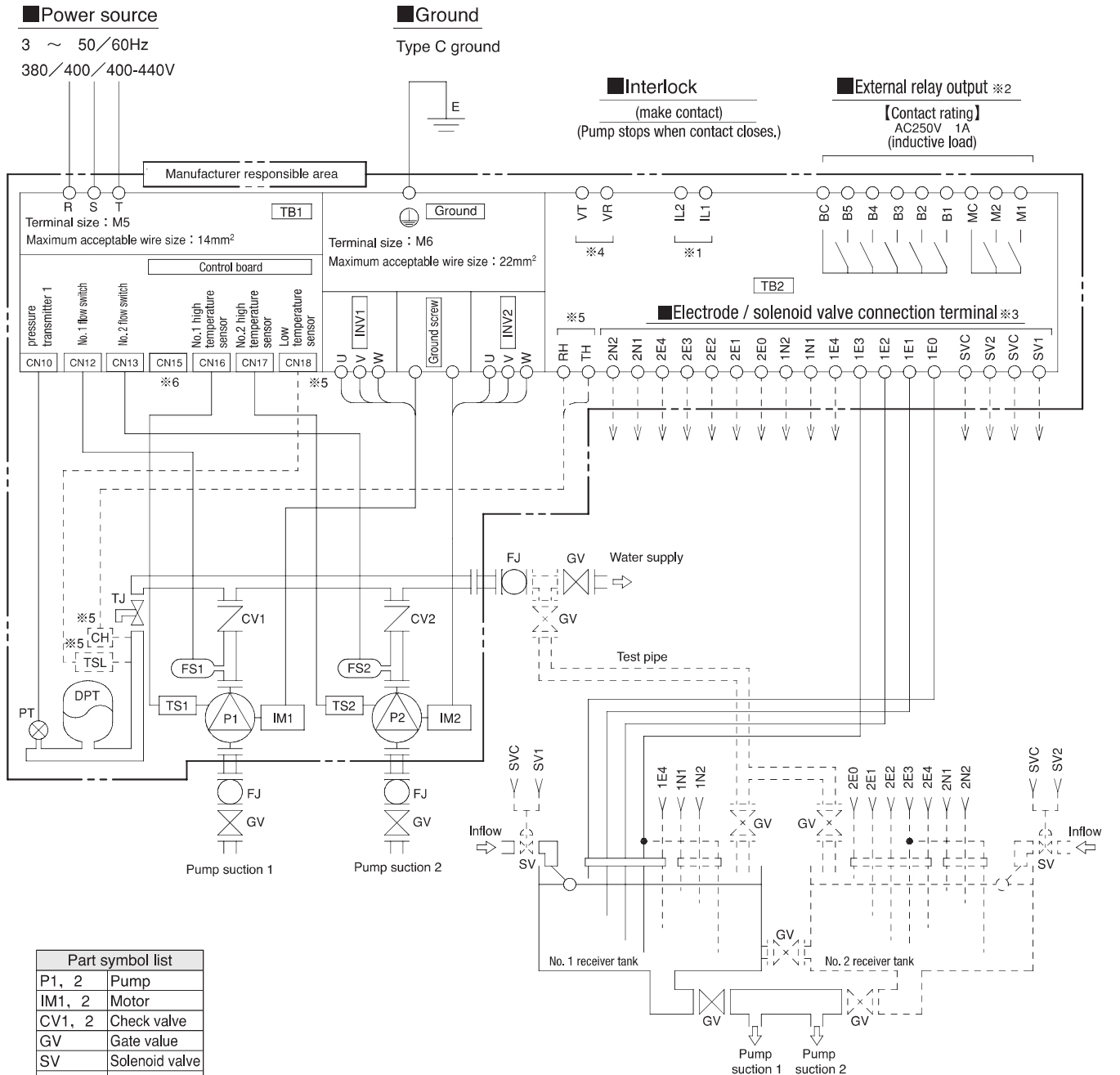

| Part symbol list |                         |
|------------------|-------------------------|
| P1, 2            | Pump                    |
| IM1, 2           | Motor                   |
| CV1, 2           | Check valve             |
| GV               | Gate valve              |
| SV               | Solenoid valve          |
| FJ               | Flexible Joint          |
| DPT              | Pressure tank           |
| TS1, 2           | High temperature sensor |
| ※5 TSL           | Low temperature sensor  |
| FS1, 2           | Flow switch             |
| PT               | Pressure transmitter    |
| ※5 CH            | Heater                  |
| TJ               | TJ valve                |
| TB1, 2           | Terminal block          |
| INV1, 2          | Inverter                |

**CAUTION**  
When conducting the installation and installation-related design, refer to the installation manual without fail.

**EXPLANATION OF LINE TYPE**  
Solid line — Connections for standard functions.  
Dotted line ..... Connections available for optional functions.

| TB2 Terminal layout   | Terminal size:M3           | Maximum acceptable wire size:1.25mm <sup>2</sup> |
|---|----------------------------|--|
| IL1 IL2 1E0 1E1 1E2 1E3 1E4 1N1 1N2 2E0 2E1 2E2 2E3 2E4 2N1 2N2 | M1 M2 MC B1 B2 B3 B4 B5 BC | TH RH SV1 SVC SV2 SVC VR VT                      |

- ※1 This is connected when the interlock function is used. Though the interlock input signal is the make contact when delivered, it can be changed to the break contact by settings.
- ※2 Content of the external relay output can be change by settings. For further details, see the connection pattern diagram.
- ※3 Depending on the setting, the system can be expanded to double receiver tanks, 5P electrodes and solenoid valves. For further details on the wiring, see the connection pattern diagram. Voltage of solenoid valve is 200V. Total current of solenoid valve must not exceed 0.3A.
- ※4 This terminal is for the cooling fan of outdoor guard. Please do not use other equipment.
- ※5 The low temperaure sensor and heater for the freeze prevention system are provided as part of special specifaicons.
- ※6 Please do not use this connector.

# Water supply unit connection pattern diagram

## Electrode/solenoid valve connection pattern

For the receiver tank level control, the following combinations are available as user selectable options.

The unit just delivered is not given no selection about the water tank and the solenoid valve operation.

The customer is requested to select them according to their usage after the wiring work. In the water tank and solenoid valve operation selection columns, ● circle shows lighting and ○ circle shows lighting off.

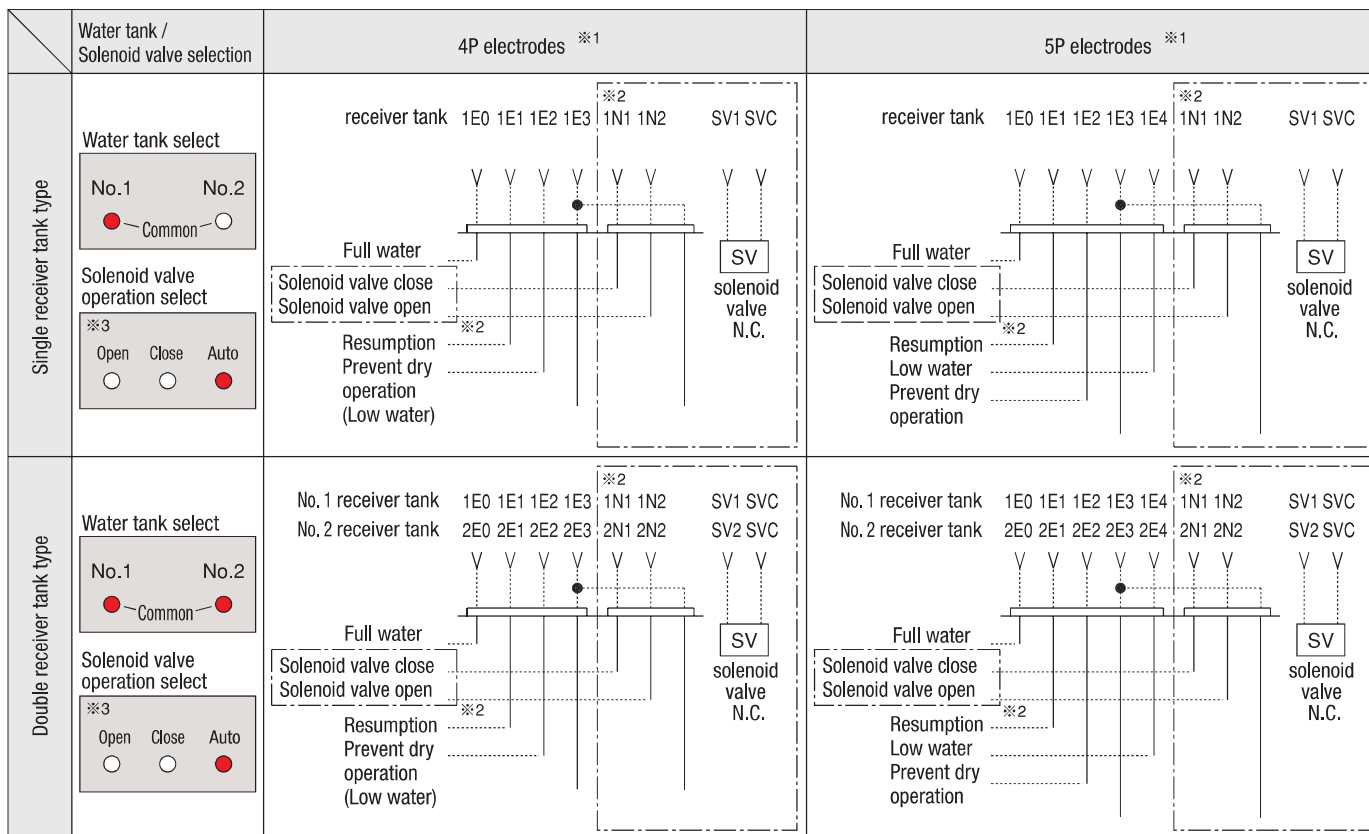

※1 The selection of 4P or 5P must be set in the micro processor through the control panel operation. (Setting before delivery : 4P)

※2 To be connected if a solenoid valve is used. The voltage of solenoid valve output is 200V. Total current of solenoid valve must not exceed 0.3A.

※3 Select Auto if a solenoid valve is used or close if a solenoid valve is not used.

## External relay output pattern

For the external relay output, the following patterns are available. (Setting before delivery : pattern=0)

|              | Set No. | Pattern 0                         | Pattern 1                      | Pattern 2                          | Pattern 3                          | Pattern 4                         |
|--------------|---------|-----------------------------------|--------------------------------|------------------------------------|------------------------------------|-----------------------------------|
| Terminal No. | M1      | No. 1 run                         | No. 1 run                      | No. 1 run                          | No. 1 run                          | Run                               |
|              | M2      | No. 2 run                         | No. 2 run                      | No. 2 run                          | No. 2 run                          | On inspection                     |
|              | B1      | No. 1 failure <sup>※4</sup>       | Serious failure <sup>※7</sup>  | Overload                           | Inverter trip <sup>※5</sup>        | No. 1 failure <sup>※4</sup>       |
|              | B2      | No. 2 failure <sup>※4</sup>       | Slightly failure <sup>※8</sup> | Discharge pressure abnormal drop   | Discharge pressure abnormal drop   | No. 2 failure <sup>※4</sup>       |
|              | B3      | Full water                        | —                              | Electric leakage                   | Electric leakage                   | Full water                        |
|              | B4      | Low water / Prevent dry operation | —                              | Abnormal water level <sup>※9</sup> | Abnormal water level <sup>※9</sup> | Low water / Prevent dry operation |
|              | B5      | Trouble <sup>※6</sup>             | Any failures <sup>※10</sup>    | Any failures <sup>※10</sup>        | Any failures <sup>※10</sup>        | Trouble <sup>※6</sup>             |

※4 Contents of No.X failure: No.X discharge pressure abnormal drop, No.X electric leakage, No.X high temperature, No.X flow switch abnormal, No.X inverter trip<sup>※5</sup>.

※5 Contents of inverter trip: Motor overload, overcurrent, overvoltage, Stall prevention, inverter overload, inverter overheat, communication alarm, inverter trouble 1, inverter trouble 2.

※6 Contents of trouble: start up frequency abnormal, pressure transmitter 1 abnormal, electrode abnormal, EEPROM error,

※7 Contents of serious failure: This is output if an error occurrence leads to water supply stop.

※8 Contents of slightly failure: This is output if an error occurs but it does not cause water supply stop.

※9 Contents of abnormal water level: full water, low water, prevent dry operation, electrode abnormal.

※10 Any failures is outputted irrelevant of the contents if an abnormal occurs.

# NX-VFC

## Water supply unit specifications

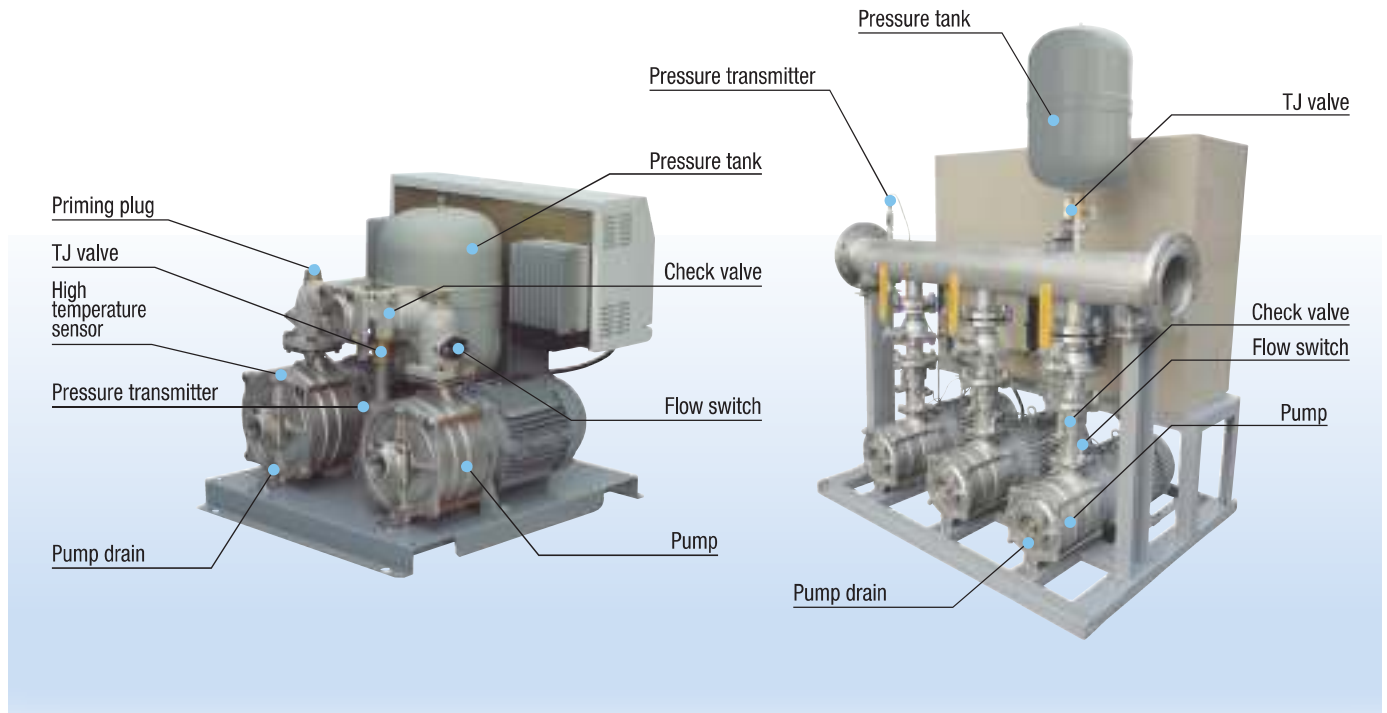

### ▼ Water supply unit specification

|                          |                  |   |
|--------------------------|------------------|---|
| Operation mode           |                  | D : Automatic alternate<br>W : Automatic alternate parallel<br>WX3 : 2-pumps Parallel, 3-pumps Rotation<br>TX3 : 3-pumps Parallel, 3-pumps Rotation<br>TX4 : 3-pumps Parallel, 4-pumps Rotation<br>FX4 : 4-pumps Parallel, 4-pumps Rotation<br>FX5 : 4-pumps Parallel, 5-pumps Rotation<br>GX5 : 5-pumps Parallel, 5-pumps Rotation |
| Control system           |                  | Estimated end pressure constant control<br>/Discharge pressure constant control by frequency control  |
| Liquid to be handled     | Quality          | Clear water   |
|                          | Temperature      | 0 to 40°C   |
| Installation environment |                  | Indoor (0 to 40°C, RH 85% or less, No dew condensation allowed),<br>Altitude 1,000m or less   |
| Suction condition        |                  | Positive suction model: up to 5m for Inflow head<br>Negative suction model: 4m for actual head and 6m (at a water temperature of 20°C) for total head   |
| Pump (material)          |                  | NX type stainless horizontal multistage centrifugal pump<br>(Impeller:SUS304, Casing:SCS13, Main shaft:SUS304)  |
| Motor                    | Type             | Totally-enclosed-fan-cooled motor (TEFC) for indoor use   |
|                          | Protection meted | IP44  |
|                          | Pole number      | 2 poles   |
| Flange                   | Suc.             | Frang for exclusive use   |
|                          | Dis.             | D/W: Flange for exclusive use<br>W3/T3/T4/F4/F5/G5: DN flange (PN10)  |
| Power supply             |                  | 3-phase 380-400/400-440V (50/60Hz)  |
| Pressure tank            |                  | D/W: DPT10 (10L Diaphragm tank)<br>W3/T3/T4/F4/F5/G5: DPT20 (20L Diaphragm tank)  |
| Pressure detector        |                  | Pressure transmitter<br>Transmission method: DC5V 3-line type<br>Output voltage: Between 0.5 and 3.5V DC  |

# Control panel specifications

## ▼ Control panel specification

| Control panel type                    |   | BQNXC   |                 | BQEC                                      |   |
|---------------------------------------|---|---|-----------------|---|---|
| Item                                  |   | Specification 1                                     | Specification 2 | Standard specification                    |   |
| Operation mode                        |   | Automatic alternate (D)<br>Automatic parallel (W)   |                 | Automatic rotation<br>(W3/T3/T4/F4/F5/G5) |   |
| Casing material and external color    |   | Steel plate (Munsell 5Y7/1 semi-gloss/baking paint) |                 |   |   |
| Output range                          | 3-phase, 380-400/400-440V (50/60Hz)                         | 0.4 - 7.5 kW  |                 | 1.1 - 15 kW                               |   |
| Circuit structure                     | Earth leakage breaker                                       | ea. pump system                                     |                 | ○   |   |
|                                       | Power factor improvement reactor (DCR)                      | ea. pump system                                     |                 | —   |   |
|                                       | Motor protection  | —   |                 | Inverter (electronic thermal)             |   |
|                                       | Double receiver tank circuit                                | Changeable from the operation panel                 |                 | ○   |   |
|                                       | Inflow solenoid valve circuit                               | Operable from the operation panel                   |                 | ○   |   |
|                                       | Electrode 5P circuit  | —   |                 | ○   |   |
| Function                              | Pump preventing dry operation                               | —   |                 | ○   |   |
|                                       | Automatic change at fault                                   | —   |                 | ○   |   |
|                                       | Pump continuous operation preventing function               | —   |                 | ○   |   |
|                                       | Function to equalize the pump operating time                | —   |                 | ○   |   |
|                                       | Applicable for external stop signal (interlock)             | Applicable for "a" / "b" contact                    |                 | ○   |   |
|                                       | Buzzer stop timer setting                                   | 1 to 60minutes, ∞, no buzzer                        |                 | ○   |   |
|                                       | Full/low water level alarm automatic return setting         | —   |                 | ○   |   |
|                                       | Inflow solenoid valve automatic alternate operation setting | —   |                 | ○   |   |
|                                       | Inspection mode   | —   |                 | ○   |   |
|                                       | Alarm buzzer  | —   |                 | ○   |   |
|                                       | Buzzer stop switch  | —   |                 | ○   |   |
|                                       | Indicator lamp  | Power supply  | —               |   | ○ |
|                                       |   | Run (ea. pump)                                      | —               |   | ○ |
| Inhibition (ea. pump)                 |   | —   |                 | ○   |   |
| Abnormal (all)                        |   | —   |                 | ○   |   |
| Other displays                        | Discharge pressure  | Unit:m•H2O  |                 | ○   |   |
|                                       | Supply voltage  | Unit:V  |                 | ○   |   |
|                                       | Working current (ea. pump)                                  | Unit:0.1A   |                 | ○   |   |
|                                       | Working frequency (ea. pump)                                | Unit:0.1Hz (only in the automatic mode)             |                 | ○   |   |
|                                       | Accumulated run time (ea. pump)                             | Unit:hour   |                 | ○   |   |
|                                       | Accumulated number of start (ea. pump)                      | Unit:one time                                       |                 | ○   |   |
|                                       | Number of unit start  | Starting frequency on the previous day              |                 | ○   |   |
|                                       | Alarm history   | Past 5 histories                                    |                 | ○   |   |
| Alarm display                         | Interlocking applied  | —   |                 | ○   |   |
|                                       | Full water  | No.:E001  |                 | ○   |   |
|                                       | Low water   | No.:E002  |                 | ○   |   |
|                                       | Preventing dry operation                                    | No.:E003  |                 | ○   |   |
|                                       | Abnormal electrode  | No.:E004  |                 | ○   |   |
|                                       | Abnormal starting frequency                                 | No.:E006  |                 | ○   |   |
|                                       | Abnormal pressure transmitter 1                             | No.:E051  |                 | ○   |   |
|                                       | EEPROM error  | No.:E080  |                 | ○   |   |
|                                       | Overload (ea.)  | No.:E#01  |                 | ○   |   |
|                                       | Discharge pressure abnormal drop (ea.)                      | No.:E#02  |                 | ○   |   |
|                                       | Electric leakage (ea.)                                      | No.:E#03  |                 | ○   |   |
|                                       | High temperature (ea.)                                      | No.:E#04  |                 | ○   |   |
|                                       | Abnormal flow switch (ea.)                                  | No.:E#05  |                 | ○   |   |
|                                       | Over-current (ea.)  | No.:E#11  |                 | ○   |   |
|                                       | Over voltage (ea.)  | No.:E#12  |                 | ○   |   |
|                                       | Low voltage (ea.)   | No.:E#13  |                 | —   |   |
|                                       | Stall prevention (ea.)                                      | No.:E#14  |                 | ○   |   |
|                                       | Input open phase (ea.)                                      | No.:E#14  |                 | —   |   |
|                                       | Inverter overload (ea.)                                     | No.:E#15  |                 | ○   |   |
|                                       | Output open phase (ea.)                                     | No.:E#16  |                 | —   |   |
| Inverter overheating (ea.)            | No.:E#17  |   | ○               |   |   |
| Abnormal inverter communication (ea.) | No.:E#18  |   | ○               |   |   |
| Inverter trouble 1 (ea.)              | No.:E#19  |   | ○               |   |   |
| Inverter trouble 2 (ea.)              | No.:E#20  |   | ○               |   |   |
| External output                       | Power supply for alarm                                      | AC200V  |                 | —   |   |
|                                       | nflow solenoid valve output                                 | AC200V  |                 | ○ (Open/close type is selectable)         |   |
|                                       | Operation signal  | No-voltage "a" contact                              |                 | ○ (ea.)                                   |   |
|                                       | Fault signal  | No-voltage "a" contact                              |                 | ○ (5 points: patterns 0 to 4)             |   |

※1. Powe voltage and operating current values are estimated. An approximately 10% difference exists against full scale.  
 ※2. " # " is the number of particular pump.

# Home Pumps

## Small pumps

Household pumps used in houses and housing complexes. We offer ideas for pressure pumps, deep well pumps, submersible pumps, etc. that are tailored to installation sites and conditions of use.

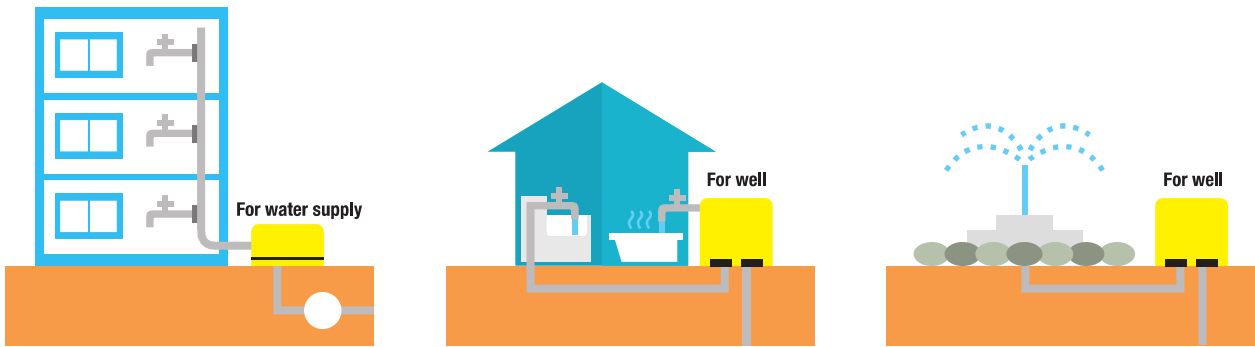

Shallow well constant pressure water supply pump  
**THP5**



Shallow well automatic pump  
**WP**



Shallow/deep well automatic pump  
**KP**



Deep well multistage inverter turbine submersible pump  
**TWS-V**



Shallow/deep submersible pump  
**HKP**



Shallow well inverter pump  
**THP5 -V**



Shallow well manual pump  
**CP**

# Shallow well inverter pump THP5-V

## Abundant suction volume

Inverter control supplies constant discharge pressure water even when the volume of water used fluctuates!!



### New DC brushless molded motor used

An advanced functions (safety, low noise, compact size, rust-free) pump has been realized by using an all-new high performance brushless molded motor.



### Easier construction work

Since two inlet and two outlet ports are provided, piping and installation freedom has been increased.

### Use of sealed cover

The entry of harmful insects and dust has been prevented and noise has been reduced by sealing the outdoor cover.

### Low noise

It is a quiet pump.  
Noise has been lowered to

## 43dB

(20% reduction at 150W,  
TERAL products comparison)

### Energy saving

Electricity cost is  
reduced considerably.

## 50%

(TERAL products comparison)

### Safety measures

Greater safety  
has been achieved  
by using a molded motor.

### Compactness

Overall size has been  
made smaller and lighter.

## 25%reduction

(at 250W, TERAL products comparison)

### Freezing prevention

To prevent the pump body  
from freezing, the motor is run  
at low speed at 5°C or lower  
and is stopped at 7°C.

### Rust-free

The plumbing and base are  
made of resin to prevent rust.

| Model No.  | Output (W) | Voltage (V) | Frequency (Hz) | Suction height (m) | Push-up height (m) | Suction volume (L/min)<br>(Total head)<br>(Suction height 2m) | Inlet port dia. (mm) | Outlet port dia. (mm) | Product weight (kg) |
|------------|------------|-------------|----------------|--------------------|--------------------|---|----------------------|-----------------------|---------------------|
| THP2-V150S | 150        | 100         | 50/60          | 8                  | 12                 | 19  | 25                   | 25                    | 12                  |
| THP2-V250S | 250        | 100         | 50/60          | 8                  | 14                 | 30  | 25                   | 25                    | 12                  |
| THP2-V400S | 400        | 100         | 50/60          | 8                  | 17                 | 38  | 25                   | 25                    | 12.5                |
| THP2-V750  | 750        | 200         | 50/60          | 8                  | 20                 | 58  | 32                   | 32                    | 19.5                |

Suction height (-2m)

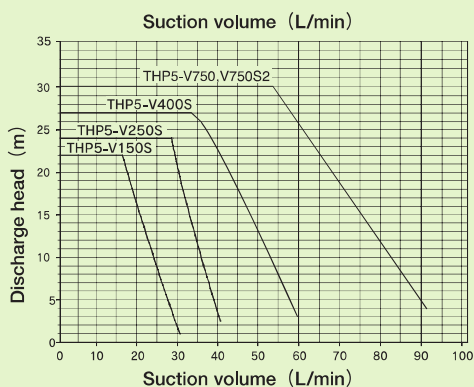

### Outline dimensions

V150S, V250S, V400S

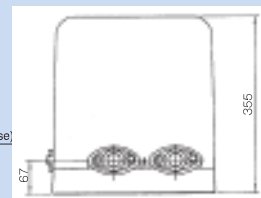
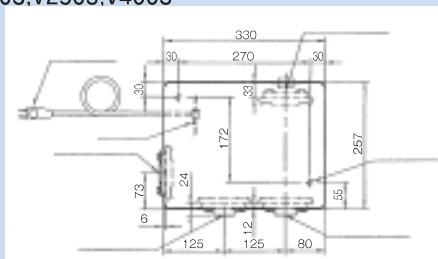

V750, V750S2

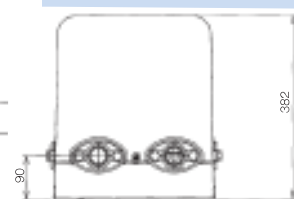
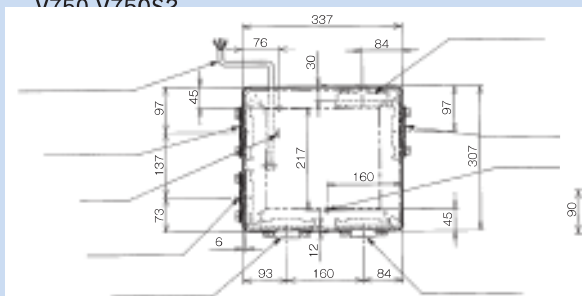

Your Dealer

**TERAL**

**TERAL INC.**

Head Office 230, Moriwake, Miyuki-cho, Fukuyama-city, Hiroshima, 720-0003, Japan Tel.+81-84-955-1111 Fax.+81-84-955-5777  
[www.teral.net](http://www.teral.net)

**TERAL ASIA LTD.**

Room 1001, 10/F, Olympia Plaza, 255 King's Road, North Point, Hong Kong Tel.+852-2571-0886 Fax.+852-2571-0619

**TERAL THAI CO., LTD.**

**TERAL TRADING & SERVICE CO., LTD.**

150 Moo 16 Udomsorasayuth Rd., T.Bangkrasan, A.Bangpa-In, Ayutthaya 13160 Thailand Tel.+66-3522-0640 Fax.+66-3522-1259

**TERAL GENERAL MACHINE (SHANGHAI) CO., LTD.**

No.285, Yuan Qu Road(N), Bei Qiao, Min Hang District, Shanghai 201109, China Tel.+86-21-6490-9128 Fax.+86-21-6490-9126