

**ShinMaywa**

# **Submersible Pumps**

**(Non-Clogging Type) CN/CNH·CNL Series**



**“SUBMERSIBLE SLUDGE PUMP” ~ CN Series**  
—Suitable for transfer and discharge of Sludge  
at sewage treatment plant

## Features And Construction

### Cable outlet with core sealer

The self-contained core sealer of the cable outlet shuts the water out from penetrating into the motor chamber through the core wires even if the cable tip is immersed in water or the sheath is damaged.



### Motor protector

A built-in automatic reset type motor protector (automatic cutoff or thermal protector) positively protects the motor from burnout due to overload, impeller clogging and open phase.



### Motor

Air-filled submersible motor with Class E insulation is employed.

### Shaft seal

A highly wear resistant silicon carbide double mechanical seal positively prevents the water from penetrating into the motor chamber. Besides, combined use of an oil seal further extends the service life of the mechanical seal.



### Discharge connection

When the auto-connection type submersible pump is lowered along with the guide pipe, the pump is automatically connected to the discharge pipe with the Discharge connection.

### Impeller

Impellers most suitable for respective pump applications are employed.

For example, the non-clogging type channel impellers are 100% subject to the dynamic and static balance adjustment at factory.

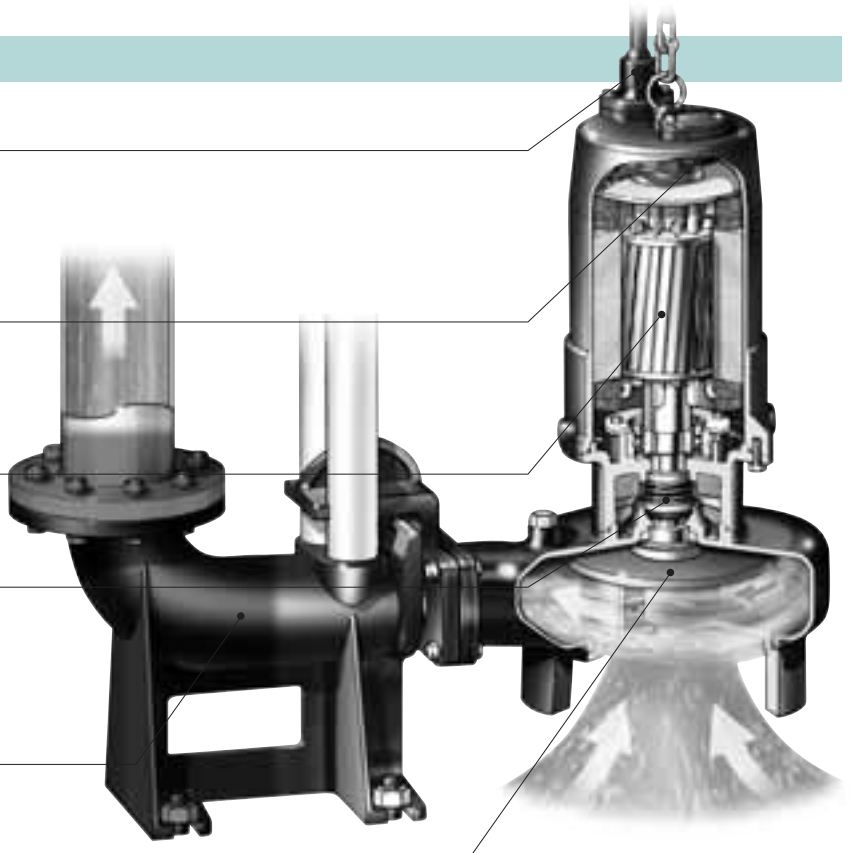

#### Semi-open type

CN40T-501(T)-651-80-100  
CNL Series



#### Closed type

CNH100  
CN150

# An Improved Pump Efficiency and Non-clogging Operation

There are **MANY ADVANTAGES** with ShinMaywa Submersible Pump.

## Applications

- Treatment processes at septic tanks
- Treatment processes at sewage-treatment plants and night-soil treatment plants
- Transfer Pumping station in the sewerage system
- Effluent from building facilities as sanitary equipment
- Draining rainwater from roads or underpass
- Treatment processes at industrial water treatment facilities

## Main Specification

<b>Handling Liquid</b>	Kind of Liquid	Sewage water
	Temperature	0 - 32°C
<b>Material</b>	Cable	7.5 kW or lower: VCT 11 kW or higher: 2PNCT
	Motor Shaft	Stainless steel (SUS420J2)
	Pump Casing	FC200 (FC250 for $\phi$ 150 only)
	Impeller	FC200 (0.25 - 7.5kW) And CNH100 of 11 or 15 kW) FC250 (CN150 11kW,15kW) FCD500 (22kW)
<b>Electric Motor</b>	Name	Air-filled Submersible Induction Motor
	Insulation Class	Class E
	Enclosure	IP68
	Phase	3-phase
	Voltage	200 - 480V

FC : Gray iron casting FCD: Ductile iron casting

## Special Specification

<b>Motor Insulation</b>	Class F
<b>Cable Extension</b>	Cable length: 10 to 30 m (every 5m)
<b>Material Change</b>	Impeller Stainless steel casting (SCS13)
	Base Cover Stainless steel casting (SCS13) Lifting Chain Stainless steel (SUS304)
<b>Other</b>	<ul style="list-style-type: none"> <li>•Availability of mounting motor protector, please refer to the specifications in the color pages.</li> <li>•For specifications other than the above, please contact us.</li> </ul>

## AUTO-CONNECTION SIMPLIFIES MAINTENANCE



One of the reasons why ShinMaywa submersible pumps are popular is the auto-connection device.

When the pump is lowered along the guide pipe, the pump is connected with the discharge tube via the connection and can be taken out of the pump pit just by lifting it up. Bolts, nuts, and packing are not used in the connected portion. This auto-connection facilitates maintenance, eliminating the need to enter the pump pit to lift the pump up, dipping out sewage water or tightening or loosening bolts.

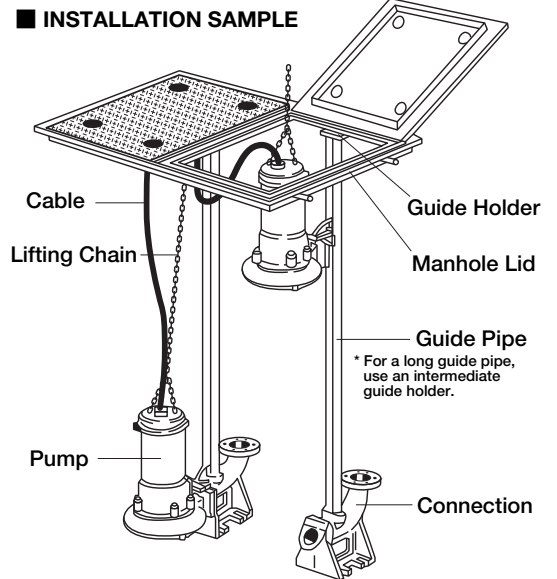

### P TYPE Auto-Connection Type

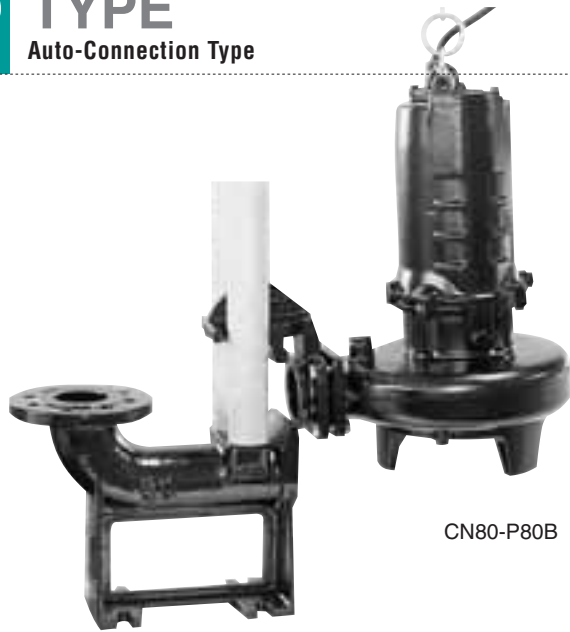

#### Application example

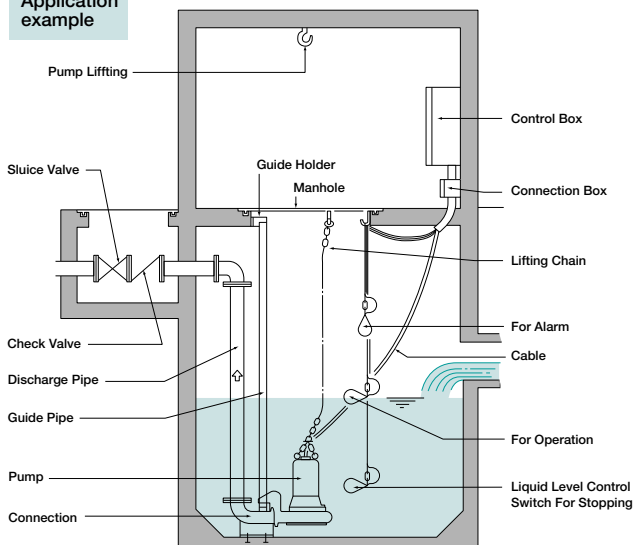

### F TYPE Free Standing Type



#### Application example

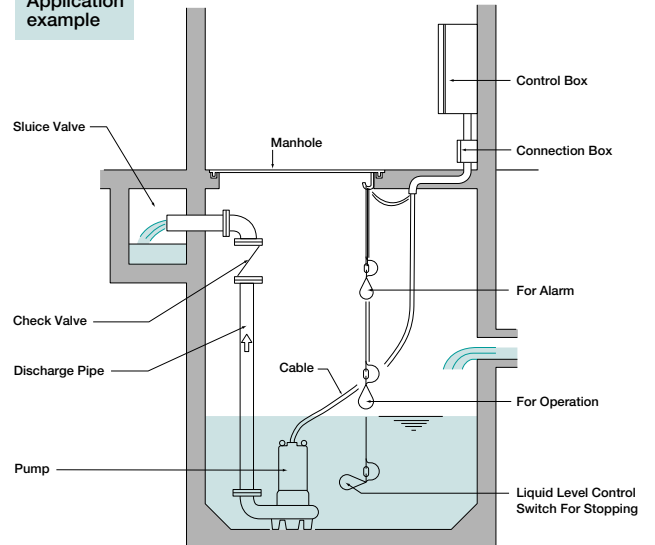

# CN/CNH Series

〈Bore〉 40~150mm  
 〈Output〉 0.25~22kW  
 〈Phase〉 3ph



## Standard Specifications

Bore mm	Pump Model	Connection Part No.		Out Put kW	No. of poles	Capacity–Total Head m <sup>3</sup> /min–m		Impeller Passage Size mm		Weight (Pump) kg		
		Auto-connection	Free standing			50Hz	60Hz	50Hz	60Hz			
40	CN40T	P40	F40	0.25	2	0.1 –5.5	0.1 –5.5	φ23*	φ23*	15.5		
50	CN501T	P50	F50	0.4	2	0.15 –6.0	0.15 –6.0	φ32*	φ32*	17		
	CN501			0.75		0.2 –8.2	0.2 –7.5			18		
65	CN501T	P65B	F65B	0.4	2	0.15 –6.0	0.15 –6.0	φ32*	φ32*	17		
	CN501			0.75		0.2 –8.2	0.2 –7.5			18		
	CN651			1.5		0.4 –10.6	0.4 –10.0			43×41	43×36	29
	CN80	P65	F65	2.2	4	0.8 –8.4	0.8 –8.6	54×60	53×60	58		
				3.7		[1] 1.0 –11.8	1.0 –11.8	53×60	54×60	70		
						[3] 0.8 –14.4						
80	CN651	P80	F80	1.5	2	0.4 –10.6	0.4 –10.0	43×41	43×36	29		
	CN80			2.2		0.8 –8.4	0.8 –8.6	54×60	53×60	58		
	CN100	P80B		3.7	4	[1] 1.0 –11.8	1.0 –11.8	53×60	54×60	70		
						[3] 0.8 –14.4						
				5.5		[1] 1.2 –12.9	[2] 1.2 –13.6	61×60	53×60	95		
						[3] 0.9 –18.0	[4] 0.9 –18.0	54×60				
7.5	[1] 1.4 –15.2	[2] 1.4 –16.7	67×60	60×60	108							
	[3] 1.0 –21.8	[4] 1.0 –22.5	56×60	62×60								
100	CN80	P100B	F100	2.2	4	0.8 –8.4	0.8 –8.6	54×60	53×60	58		
				3.7		[1] 1.0 –11.8	1.0 –11.8	53×60	54×60	70		
				[3] 0.8 –14.4								
	CN100			5.5		[1] 1.2 –12.9	[2] 1.2 –13.6	61×60	53×60	95		
						[3] 0.9 –18.0	[4] 0.9 –18.0	54×60				
	CNH100			P100C		F100B	7.5	[1] 1.4 –15.2	[2] 1.4 –16.7	67×60	60×60	108
								[3] 1.0 –21.8	[4] 1.0 –22.5	56×60	62×60	
							11	1.57 –22	1.58 –22	64×54	56×54	216
15		1.9 –26	1.86 –26		69×54		60×55	230				
150	CN150	P150	F150	22	4	1.8 –35	1.96 –35	75×55	65×58	290		
				5.5		2.0 –10	1.96 –10	70×80	65×80	122		
				7.5		2.48 –12	2.33 –12	75×85	70×80	134		
				11		2.54 –16	2.6 –16	64×100	57×100	215		
				15		2.87 –19	3.0 –19	70×95	62×100	228		
				22		3.6 –22	3.86 –22	76×100	67×105	326		

1) Starting method: Direct-on-line (7.5kW or under), Star-delta (11kW or over). (Note) Specify both pump model and connection part No. to contact our dealer.  
 2) The above impeller passage size shows dimensions of the channel in impellers, not solid passage diameter.  
 3) The impeller passage size with asterisk is an opening dimension of a strainer.

## Standard Accessories

• Cable (7.5kW or under) ..... 1pc.      6m for 0.75kW or under  
 (11kW or over) ..... 3pcs.      8m for 1.5kW or over

### Auto-Connection Kit

• Connection      • Sliding bracket  
 • Guide holder (with bolts and nuts)      • Lifting chain (6m)

Bore mm	Connection Part No.	Set Weight kg	Connection Weight kg
40	P40	11	4.5
50	P50	11	4.5
65	P65B	20	14.5
	P65	24	15
80	P80B	31.5	18
100	P100B	40.5	27
	P100C	55	37
150	P150	60	42

### Free Standing Kit

• Elbow flange  
 • Companion flange (with bolts, nuts and packing)

Bore mm	Connection Part No.	Set Weight kg
40	F40	☆
50	F50	☆
65	F65B	5.5
	F65	7
80	F80	9.5
100	F100	11
	F100B	12
150	F150	30

☆Built-in with the pump proper.

### Packing Size

Model	Length mm	Width mm	Height mm	
CN40T	285	× 205	× 475	
CN501T	280	× 195	× 460	
CN501				
CN651	550	× 260	× 295	
CN80	2.2kW	440	× 388	× 655
	3.7kW	470	× 410	× 727
CN100	545	× 455	× 788	

\* If you would like to know packing size of CNH100 and CN150, please contact to our local sales agent.

# Performance Curves

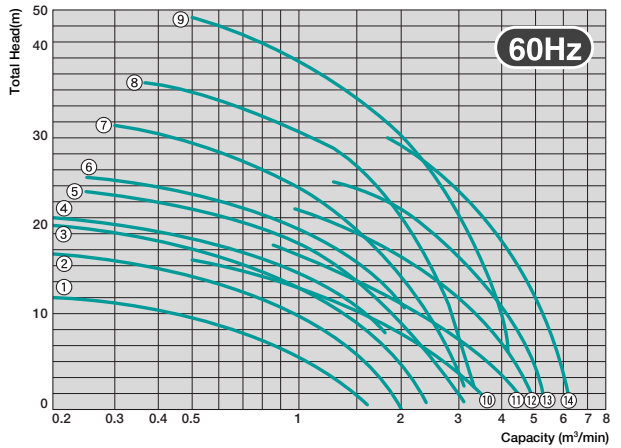
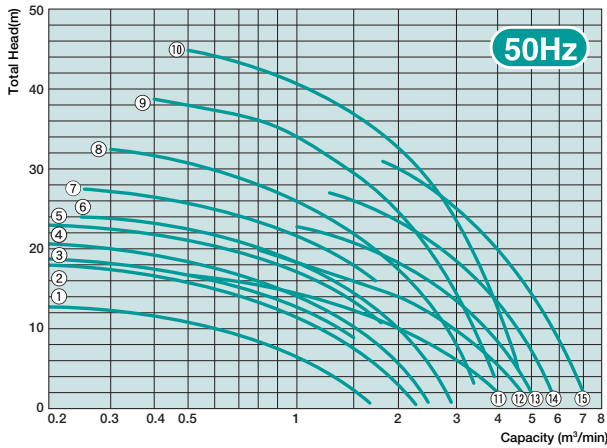
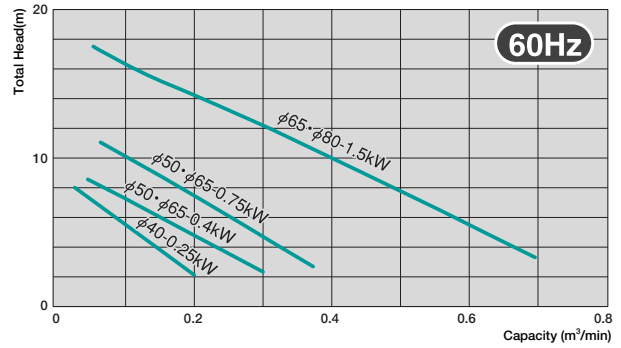
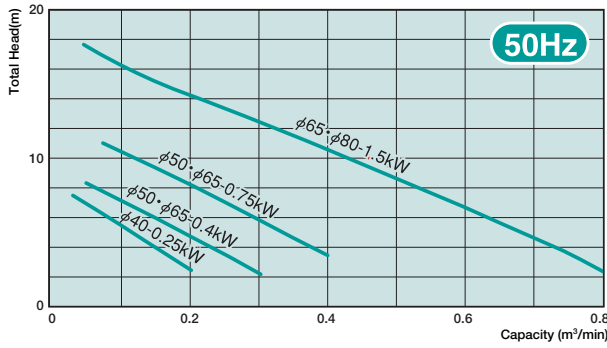

- ① CN80 φ65·φ80·φ100-2.2kW
  - ② CN80 φ65·φ80·φ100-3.7kW [1]
  - ③ CN80 φ65·φ80·φ100-3.7kW [3]
  - ④ CN100 φ80·φ100-5.5kW [1]
  - ⑤ CN100 φ80·φ100-5.5kW [3]
  - ⑥ CN100 φ80·φ100-7.5kW [1]
  - ⑦ CN100 φ80·φ100-7.5kW [3]
  - ⑧ CNH100 φ100-11kW
  - ⑨ CNH100 φ100-15kW
  - ⑩ CNH100 φ100-22kW
  - ⑪ CN150 φ150-5.5kW
  - ⑫ CN150 φ150-7.5kW
  - ⑬ CN150 φ150-11kW
  - ⑭ CN150 φ150-15kW
  - ⑮ CN150 φ150-22kW
- [ ] : Code No. of impeller

- ① CN80 φ65·φ80·φ100-2.2kW
  - ② CN80 φ65·φ80·φ100-3.7kW
  - ③ CN100 φ80·φ100-5.5kW [2]
  - ④ CN100 φ80·φ100-5.5kW [4]
  - ⑤ CN100 φ80·φ100-7.5kW [2]
  - ⑥ CN100 φ80·φ100-7.5kW [4]
  - ⑦ CNH100 φ100-11kW
  - ⑧ CNH100 φ100-15kW
  - ⑨ CNH100 φ100-22kW
  - ⑩ CN150 φ150-5.5kW
  - ⑪ CN150 φ150-7.5kW
  - ⑫ CN150 φ150-11kW
  - ⑬ CN150 φ150-15kW
  - ⑭ CN150 φ150-22kW
- [ ] : Code No. of impeller

# Dimensions

## Auto-Connection

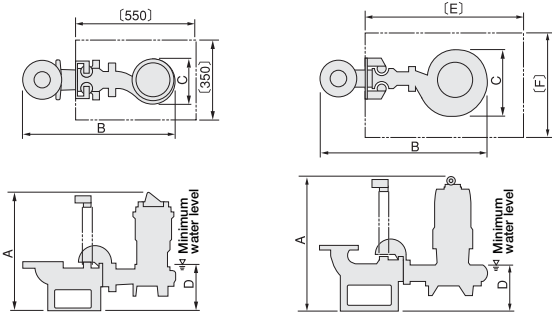

## Free Standing

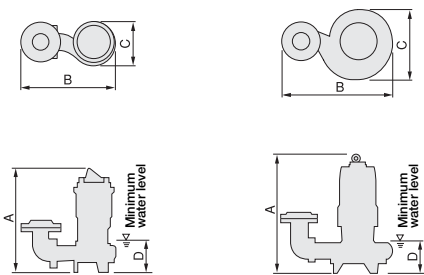

Pump Model	Connection Parts No.	Output kW	A	B	C	D	E	F			
CN40T	P40	0.25	431	431	164	180	550	350			
CN501T	P50	0.4	460	447	170	180	550	350			
		0.75		520							
CN651	P65	1.5	530	663	192	215	550	350			
			570	739					255		
CN80	P65	2.2	580	754	292	220	600	500			
			P80B	830		260			700		
				P100B						843	
	P80B	3.7	620	773	331	220	260	700			
			P100B	849					260	700	
				P100B							862
CN100	P80B	5.5	710	907	355	260	700	600			
				P100B					920		
	P80B	7.5	745	922	387	260	700	600			
				P100B					935		
CNH100	P100C	11	861	1,110	486	335	900	700			
		15									
		22							955	1,132	529
CN150	P150	5.5	779	1,094	400	325	900	700			
		7.5	814								
		11·15	871						1,148	450	345
		22	967						1,188	489	345

Pump Model	Connection Parts No.	Output kW	A	B	C	D			
CN40T	F40	0.25	377	233	164	125			
CN501T	F50	0.4	414	249	170	135			
		0.75		344					
CN651	F65	1.5	454	418	192	140			
				F80			433		
				F65			509		
CN80	F80	2.2	550	524	292	190			
				F100			541		
	F65	3.7	612	528	331				
				F80			543		
				F100			560		
CN100	F80	5.5	640	601	355	190			
				F100			618		
	F80	7.5	675	616	387				
				F100			633		
CNH100	F100B	11	782	848	486	255			
		15							
		22					876	870	529
		5.5					713	836	400
7.5	748								
CN150	F150	11·15	804	890	450	280			
		22	915				930	489	295
		5.5	713						
		7.5	748						

# CNL Series

<Bore> 50~80mm

<Output> 0.25~1.5kW

<Phase> 3ph

**Built-in Chopper  
4 Poles type**



CNL501-P50



CNL501-F50

## Standard Specifications

Bore mm	Pump Model	Connection Part No.		Out Put kW	No. of poles	Capacity-Total Head		Impeller Passage Size		Weight (Pump) kg
		Auto-connection	Free standing			m <sup>3</sup> /min-m		mm×mm		
						50Hz	60Hz	50Hz	60Hz	
50	CNL501	P50	F50	0.25	4	0.17-4	0.17-4.4	34×30	28×32	19
				0.4		0.25-4.5	0.24-4.5	35×35	28×40	26
				0.75		0.34-6.5	0.34-6.5	44×40	34×42	27
65	CNL501	P65B	F65B	0.4	4	0.25-4.5	0.24-4.5	35×35	28×40	26
				0.75		0.34-6.5	0.34-6.5	44×40	34×42	27
	CNL651	P65	F65	1.5		0.6-7.4	0.6-7.8	51×48	39×53	45
80	CNL651	P80	F80	1.5	4	0.6-7.4	0.6-7.8	51×48	39×53	45

1) The above impeller passage size shows dimensions of the channel in impellers, not solid passage diameter.  
2) The impeller passage size with asterisk is an opening dimension of a strainer.

## Standard Accessories

•Cable ..... 1pc.

6m for under 0.75kW

8m for 1.5kW

### Auto-Connection Kit

- Connection
- Sliding bracket
- Guide holder (with bolts and nuts)
- Lifting chain (6m)

Bore mm	Connection Part No.	Set Weight kg	Connection Weight kg
50	P50	11	4.5
65	P65B	20	14.5
	P65	24	15
80	P80	31.5	20.5

### Free Standing Kit

- Elbow flange
- Companion flange (with bolts, nuts and packing)

Bore mm	Connection Part No.	Set Weight kg
50	F50	☆
65	F65B	5.5
	F65	7
80	F80	9.5

☆Built-in with the pump proper.

### Packing Size

Model	Length mm	Width mm	Height mm
CNL501	0.25kW	310 ×	280 × 450
	0.4-0.75kW	350 ×	305 × 510
CNL651	350 ×	320 ×	580

## Performance Curves

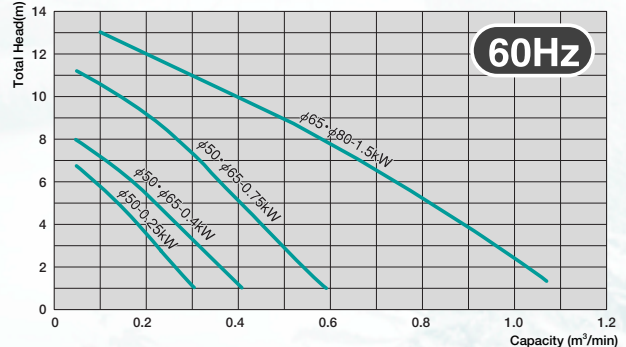
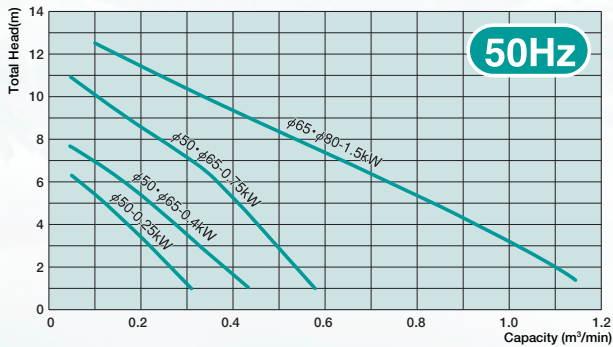

## Dimensions

### Auto-Connection

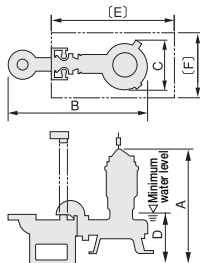

Pump Model	Connection Parts No.	Output kW	A	B	C	D	E	F
CNL501	P50	0.25	418	465	220	160	550	350
		0.4-0.75	469	506	246	165		
CNL651	P65B	1.5	564	725	302	215	550	350
	P80		604	801		255		

### Free Standing

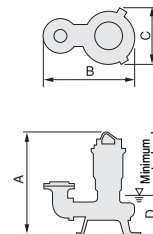

Pump Model	Connection Parts No.	Output kW	A	B	C	D
CNL501	F50	0.25	378	267	220	120
		0.4-0.75	445	308	246	140
CNL651	F65B	1.5	529	480	302	180
	F80			495		

## Sectional View

### CN Series

CN80-F80

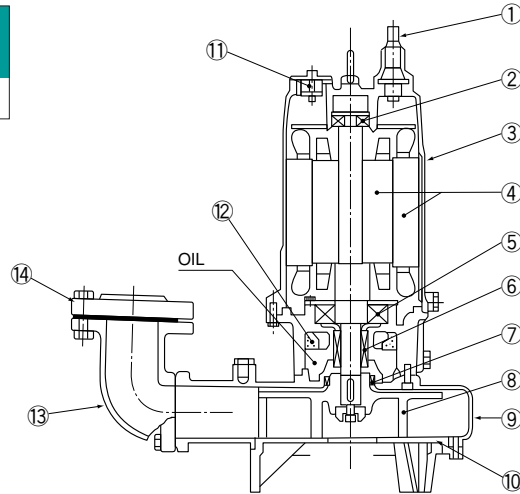

No.	Part Name	Material
1	Cable	VCT
2	Ball Bearing (Upper)	-
3	Stator Casing	FC200
4	Motor	Shaft=SUS420J2
5	Ball Bearing (Lower)	-
6	Mechanical Seal	-
7	Oil Seal	N.B.R.
8	Impeller	FC200
9	Pump Casing	FC200
10	Base Cover	FC200
11	Thermal Protector	-
12	Equalizer	N.B.R.
13	Elbow Flange	FC200
14	Companion Flange	FC200

### CNH Series

CNH100-P100C

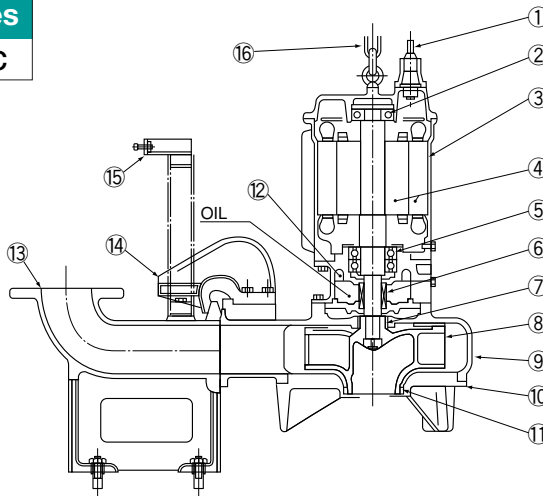

No.	Part Name	Material
1	Cable	2PNCT
2	Ball Bearing (Upper)	-
3	Stator Casing	FC200
4	Motor	Shaft=SUS420J2
5	Ball Bearing (Lower)	-
6	Mechanical Seal	-
7	Seal Ring	CAC406
8	Impeller	FC200(22kW:FCD500)
9	Pump Casing	FC200
10	Base Cover	FC200
11	Wearing	CAC406
12	Equalizer	N.B.R.
13	Connection	FC200
14	Sliding Bracket	FC200
15	Guide Holder	SCS13
16	Lifting Chain	SS400

### CNL Series

CNL651-P65

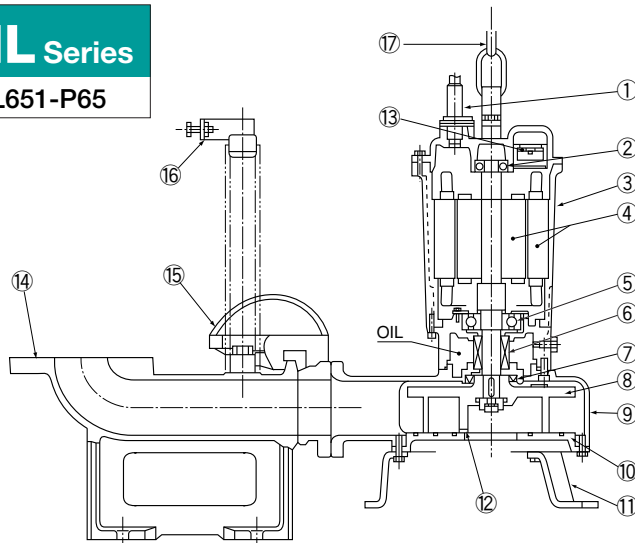

No.	Part Name	Material
1	Cable	VCT
2	Ball Bearing (Upper)	-
3	Stator Casing	FC200
4	Motor	Shaft=SUS420J2
5	Ball Bearing (Lower)	-
6	Mechanical Seal	-
7	Oil Seal	N.B.R.
8	Impeller	FC200
9	Pump Casing	FC200
10	Base Cover	FC200
11	Stand	SS400
12	Cutting Chip	WC
13	Thermal Protector	-
14	Connection	FC200
15	Sliding Bracket	FC200
16	Guide Holder	SCS13
17	Lifting Chain	SS400

# Special Accessories

**Liquid Level Regulators** - All models are non-mercury structure for earth environment.

**LC** "Level Switch"



**MS** "Mini Switch"



**FV** "Oval Float"



## Features

**LC** Useful for drinking water, waste water and sewage containing the suspended solids. Hardly affected by corrosion or rust even if it is immersed in a corrosive liquid for a long time.

**MS** Useful for waste water and sewage containing a few suspended solids. The MS is available in two types, MS11 (single float) and MS21 (double float).

**FV** Useful for the fresh water as well as waste water not containing suspended solids. A single FV is able to control both the upper and lower liquid levels.

## Specifications

Model	LC12	MS11, MS21	FV11
Switch	Micro Switch	Lead Switch	Lead Switch
Specific gravity of liquid	0.95~1.15	0.95~1.10	0.95~1.10
Liquid Temp	0~60°C	0~40°C	0~60°C
Voltage	AC/DC30V or under		
Current	5A or under	0.5A or under	0.6A
Cable Length	6m, 13m, 20m, 30m, 40m, 50m (further cable extension at interval of 10m)		
Cable Type	0.75mm <sup>2</sup> ×3 cores, Flat Type	0.2mm <sup>2</sup> ×2 cores×φ 4.7mm	0.5mm <sup>2</sup> ×2 cores×φ 5.8mm
Weight (including cable)	1.2kg (6m cable)	0.6kg (MS11, 6m cable)	1.0kg (6m cable)
Material	Case	Polypropylene resin	ABS resin
	Cable	VCTFK	PVC resin (soft type)
	Others	Chain: SUS304	Sinker: Cast iron with PVC resin coating

Specifications and dimensions are subject to change without notice.

### ShinMaywa Industries, Ltd.

International Business Group  
Sales & Marketing Dept., Fluid Div. 3-2-43, Shitte, Tsurumi-ku, Yokohama, 230-0003, Japan  
Phone : +81-45-584-1322 Fax : +81-45-575-2286  
E-mail : sales.eisui@shinmaywa.co.jp

### ShinMaywa (America), Ltd.

10737 Gateway West, Suite 240,  
El Paso, Texas 79935, U.S.A.  
Phone : +1-915-594-9862  
Fax : +1-915-594-9866  
E-mail : info@shinmaywaamerica.com

### ShinMaywa (Asia) Pte. Ltd.

8 Burn Road, #14-10 Trivex,  
Singapore 369977  
Phone : +65-6224-0728  
Fax : +65-6224-9678  
E-mail : asia.ad@shinmaywa.com.sg

### ShinMaywa (Shanghai) Trading Co., Ltd.

201107 Building 6, Lane 333, Zhujian Road,  
Minhang District, Shanghai, China  
Phone : +86-21-5296-2966  
Fax : +86-21-5296-2970  
E-mail : shanghai@shinmaywa.co.jp



**ShinMaywa ONO PLANT**

ISO 9001(No.956445)/ISO 14001(No.771888)