



SPACE TWIN

Blum's idea for narrow cabinets

www.blum.com

 **blum**[®]

A practical solution for small storage spaces

Now even the smallest spaces in the kitchen can be used. Blum's SPACE TWIN, the idea for narrow cabinets, with diagonally offset runners creates additional storage space – without compromising stability or quality of motion.

 **blum**





Proven Blum quality of motion

Blum's proven quality of motion is prominent in the SPACE TWIN narrow cabinet. Minimal opening forces, a feather-light glide and the adaptive BLUMOTION damping system for silent and effortless closing guarantee top quality of motion and enhanced user ease. What's more, the cabinet can be fully extended, providing easy access to all contents.

Optimum stability and load bearing

Diagonally offset runners ensure improved lateral stability and a high load bearing capacity of up to 20 kg per base cabinet.

Uniform appearance

The implementation in combination with the box systems LEGRABOX and TANDEMBOX or with the runner systems MOVENTO and TANDEM enables a consistent look and a uniform appearance.

Familiar ease of assembly and adjustment

The use of Blum standard fittings enables the familiar simple and convenient adjustment and assembly.

Diverse implementation options

Thanks to the consistent use of Blum fittings, SPACE TWIN is covered by the existing product range. The solution cannot only be implemented with LEGRABOX and TANDEMBOX box systems but also with MOVENTO and TANDEM runner systems.

blum®



LEGRABOX

The narrow, linear design of LEGRABOX is also used to its full advantage in narrow cabinet solutions. For cabinet width of 200 mm.



TANDEMBOX

The solution for narrow cabinets is compatible with all TANDEMBOX programme lines. For cabinet width of 200 mm.



MOVENTO

MOVENTO's quality of motion is also prominent in SPACE TWIN. For cabinet widths of 200 mm.



TANDEM

With the runner system, narrow wooden cabinets can be implemented throughout the entire living area. For cabinet widths starting at 150 mm.



SPACE TWIN



LEGRABOX

Space requirements in cabinet

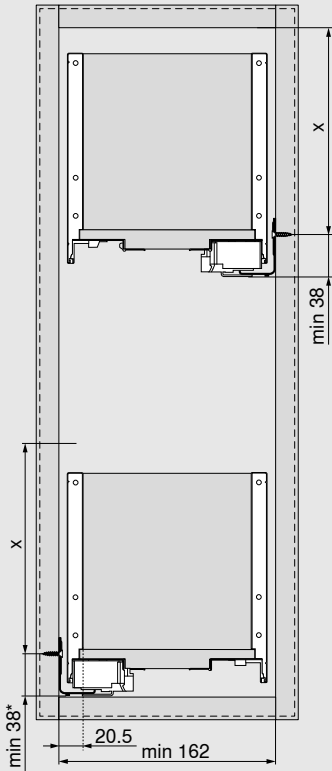

X =

Height	LEGRABOX	LEGRABOX pure	LEGRABOX free
M	68 mm	-	-
K	106 mm	-	-
C	-	155 mm	155 mm

* + 1 mm for assembly of the cabinet profile on the horizontal cabinet side

Front installation dimensions

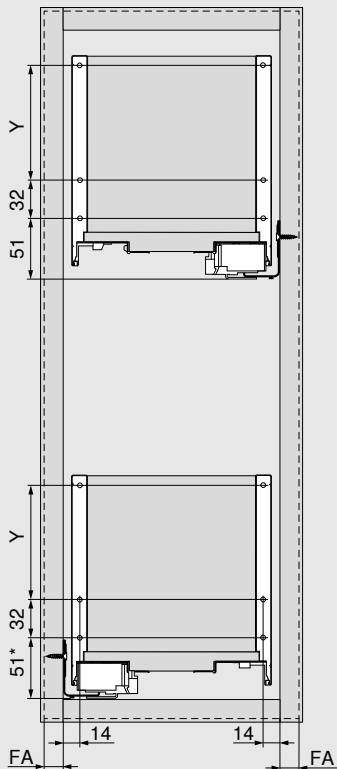

Y =

Height	LEGRABOX	LEGRABOX pure	LEGRABOX free
M	-	-	-
K	-	-	-
C	-	96 mm	96 mm

* + 1 mm for assembly of the cabinet profile on the horizontal cabinet side
FA Front overlay

Back installation dimensions

Height M

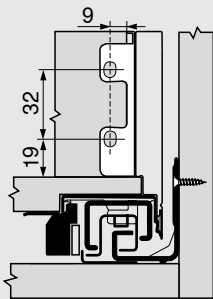

Height K

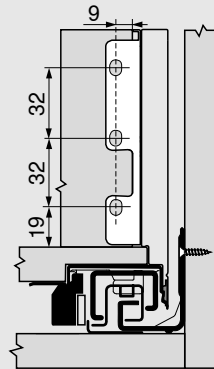

Height C

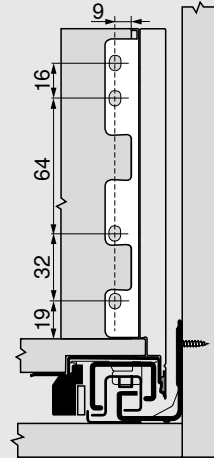

Cutting dimensions for 16 mm chipboard

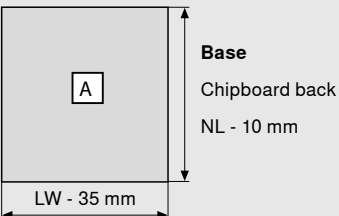
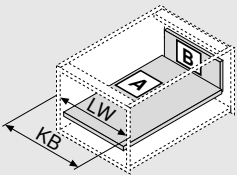

Back



Height	LEGRABOX	LEGRABOX pure	LEGRABOX free
M	63 mm	-	-
K	101 mm	-	-
C	-	148 mm	148 mm

KB Cabinet width
LW Internal cabinet width
NL Nominal length

i Note

For order specifications for standard LEGRABOX components, please see the respective product brochures or the catalogue.



➤ www.blum.com/legrabox

SPACE TWIN



TANDEMBOX

Space requirements in cabinet

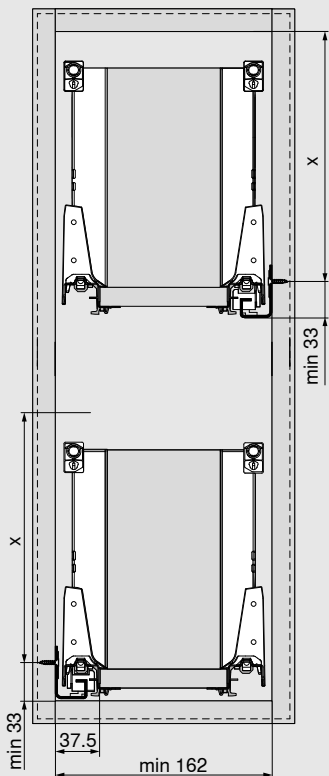

X =



Height	TANDEMBOX plus	TANDEMBOX antaro	TANDEMBOX intivo
M	63.5 mm	65.5 mm	65.5 mm
K	95.5 mm	97.5 mm	-
B	127 mm	-	-
C	-	159 mm	-
D	191 mm	191 mm	191 mm

Front installation dimensions

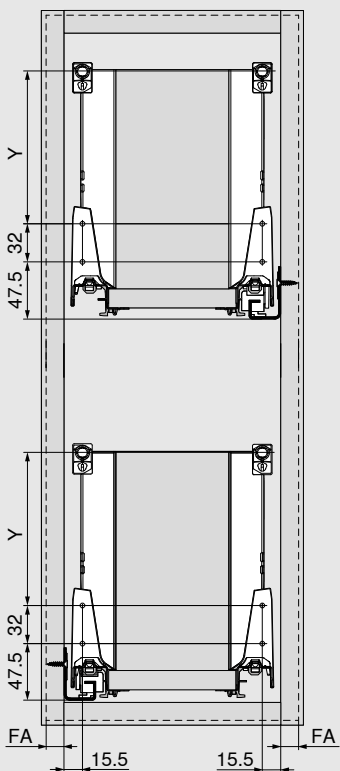

Y =



Height	TANDEMBOX plus	TANDEMBOX antaro	TANDEMBOX intivo
M	-	-	-
K	32 mm	32 mm	-
B	64 mm	-	-
C	-	96 mm	-
D	128 mm	128 mm	96 mm
with double gallery	64/64 mm	-	-
on K drawer side	-	32/96 mm	-

FA Front overlay

Back installation dimensions

Height M

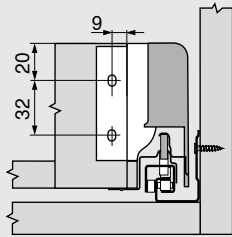

Height K

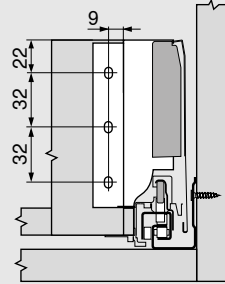

Height B

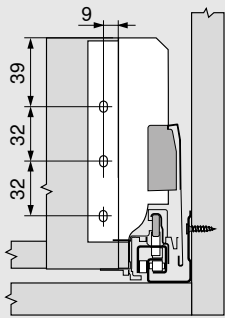

Height C

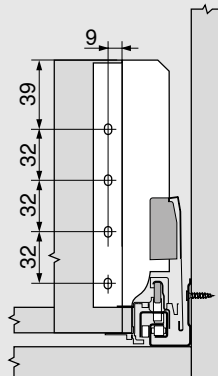

Height D

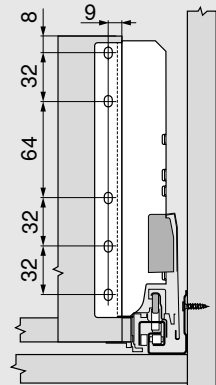

Cutting dimensions for 16 mm chipboard

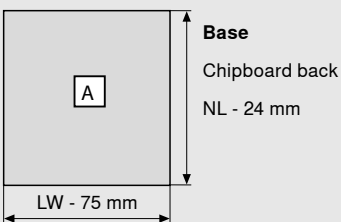
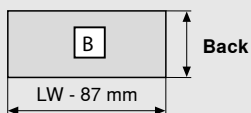
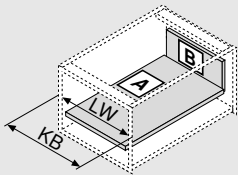

Back



	TANDEMBOX plus	TANDEMBOX antaro	TANDEMBOX intivo
Height			
M	84 mm	84 mm	84 mm
K	116 mm	116 mm	-
B	135 mm	135 mm	-
C	-	167 mm	-
D	199 mm	199 mm	199 mm

KB Cabinet width
LW Internal cabinet width
NL Nominal length

i Note

For order specifications for standard TANDEMBOX components, please see the respective product brochures or the catalogue.



➤ www.blum.com/tandembox

Drawer

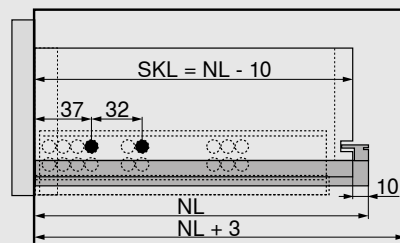
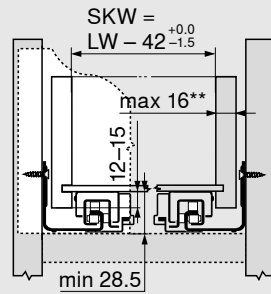
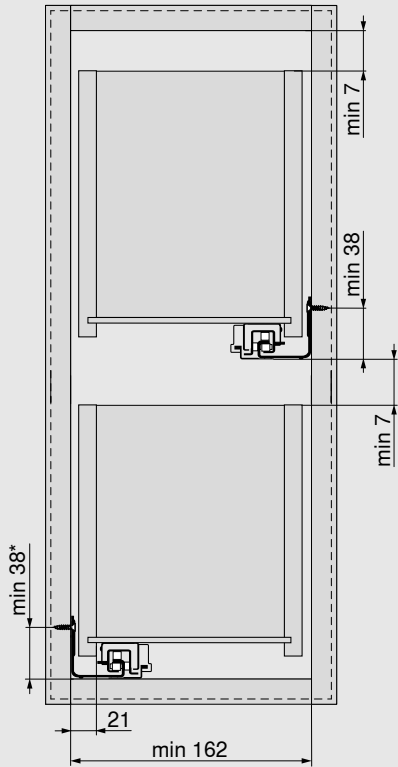

LW Internal cabinet width
 NL Nominal length
 SKL Drawer length
 SKW Internal drawer width

* + 1 mm for assembly of the cabinet profile on the horizontal cabinet side

** Limited side adjustment for a drawer side panel thickness of 16 mm, but with full tolerance utilisation of the SKW

Drawer assembly

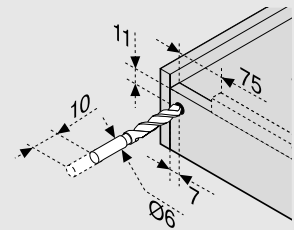
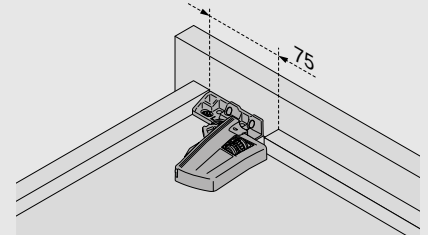

i Note

For order specifications for standard MOVENTO components, please see the respective product brochures or the catalogue.



➤ www.blum.com/movento

TANDEM

SPACE TWIN



Drawer

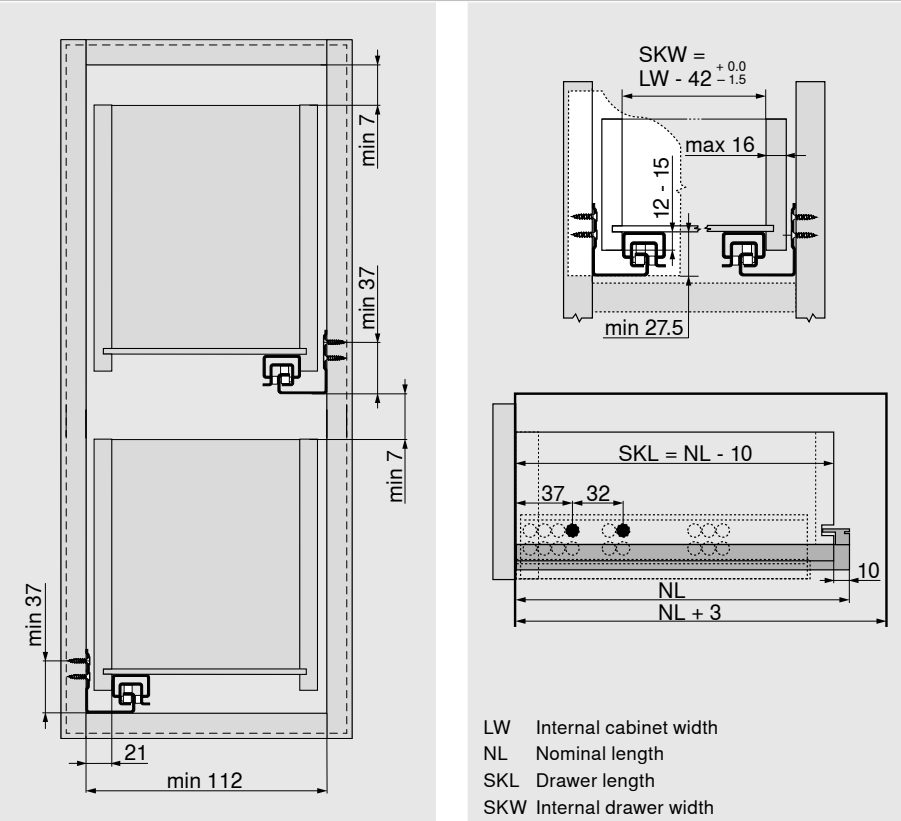

Locking device feature of drawer assembly

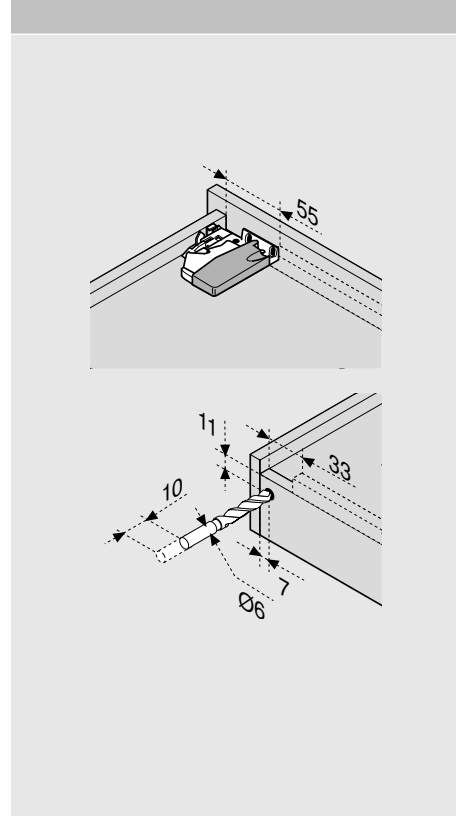

Peg variant of drawer assembly

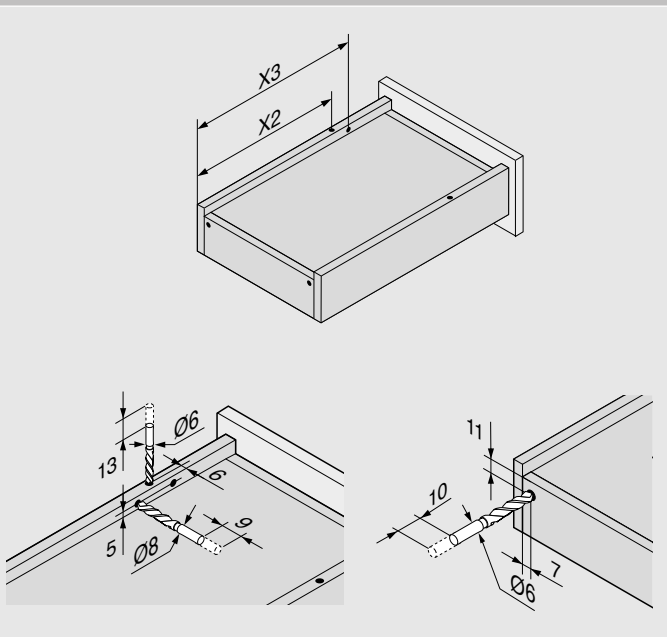

Tandem plus-561H

Nominal length	Pegs	Lift-off stop
NL (mm)	X2 (mm)	X3 (mm)
260	205	185
285	220	200
310	230	242
335	245	257
360	275	287
385	285	297
410	300	344
435	310	354
460	335	379
485	350	394
510	360	436
535	375	451
560	405	481

Note

For order specifications for standard TANDEM components, please see the respective product brochures or the catalogue.



www.blum.com/tandem

Julius Blum GmbH
Furniture Fittings Mfg.
6973 Höchst, Austria
Tel.: +43 5578 705-0
Fax: +43 5578 705-44
E-mail: info@blum.com
www.blum.com

