

MOVENTO with TIP-ON – 760H/766H

Webcode
 DQCZTA

Planning

Space requirement in cabinet

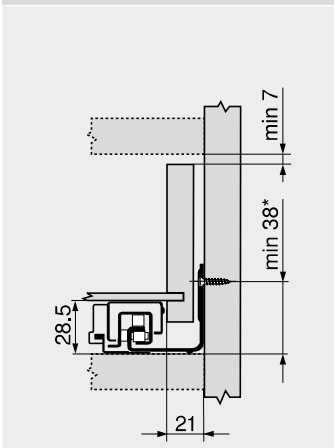

Drawer/inner drawer

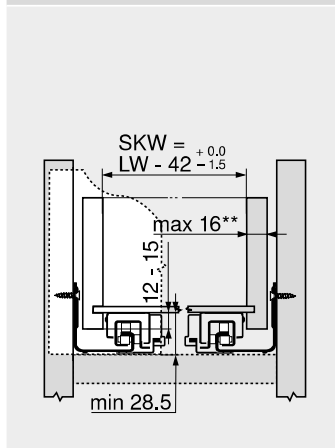

Drawer

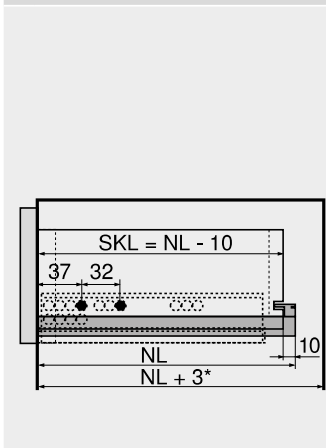

Inner drawer

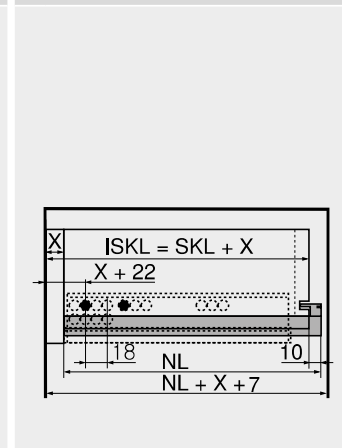

* +1 mm for assembly of the cabinet profile on the horizontal cabinet side

SKW Internal drawer width
 LW Inner cabinet width

SKL Drawer length
 NL Nominal length
 * Additional +12 mm with side stabilisation

ISKL Inner drawer length
 SKL Drawer length
 NL Nominal length

Screw position – cabinet profiles

Cabinet profile 760H – 40 kg
 Nominal length NL (mm)

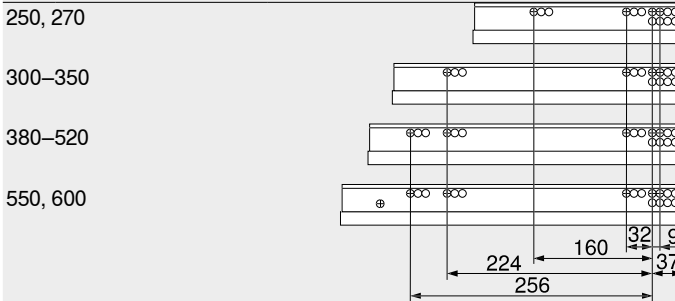

Cabinet profile 766H – 60 kg
 Nominal length NL (mm)

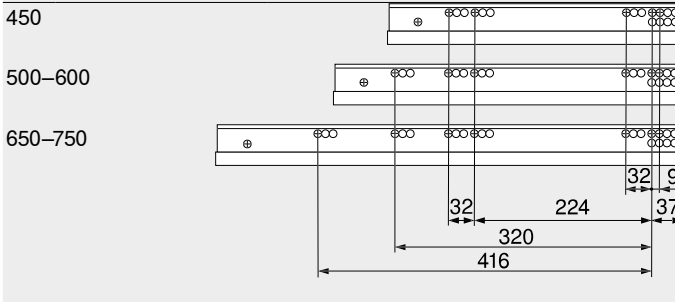

Drawer assembly

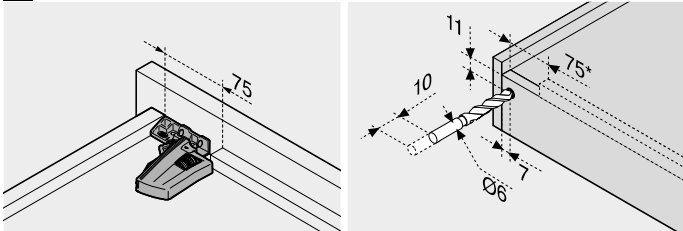

Use drilling template T65.1000.02

* TIP-ON BLUMOTION
 125 mm

Note

** Limited side adjustment for a drawer side panel thickness of 16 mm, but with full tolerance utilisation of the internal width of the drawer SKW

Page instructions

Overview – MOVENTO	427
Accessories	436
Cabinet profile fixing positions	441
Assembly, removal and adjustment	443
Overview – assembly devices	683
More technical details	774