



CLIP top BLUMOTION 107°

The secret's inside –
even with a shallow boss drilling depth

www.blum.com

 **blum**®



CLIP top BLUMOTION 107° combines technology with convenience

With CLIP top BLUMOTION 107° the secret's inside: because BLUMOTION, our function for silent and effortless closing, is also integrated into the hinge boss. Familiarise yourself with the advantages of integrated BLUMOTION.

 **blum**



Contents

- 4** Integrated BLUMOTION
- 6** Soft and effortless closing
- 8** BLUMOTION deactivation
- 10** Shallow boss drilling depth
- 12** Elegant design
- 14** Case studies
- 16** Easy assembly
- 18** Order specifications
- 20** Assembly devices for CLIP top BLUMOTION
- 22** Blum





Innovative technology within the smallest space

Precise movement like clockwork – integrated BLUMOTION is a technical wonder that fits into the smallest space, providing silent and effortless closing for furniture doors. CLIP top BLUMOTION 107° meets the highest quality requirements – for the whole life of the furniture.

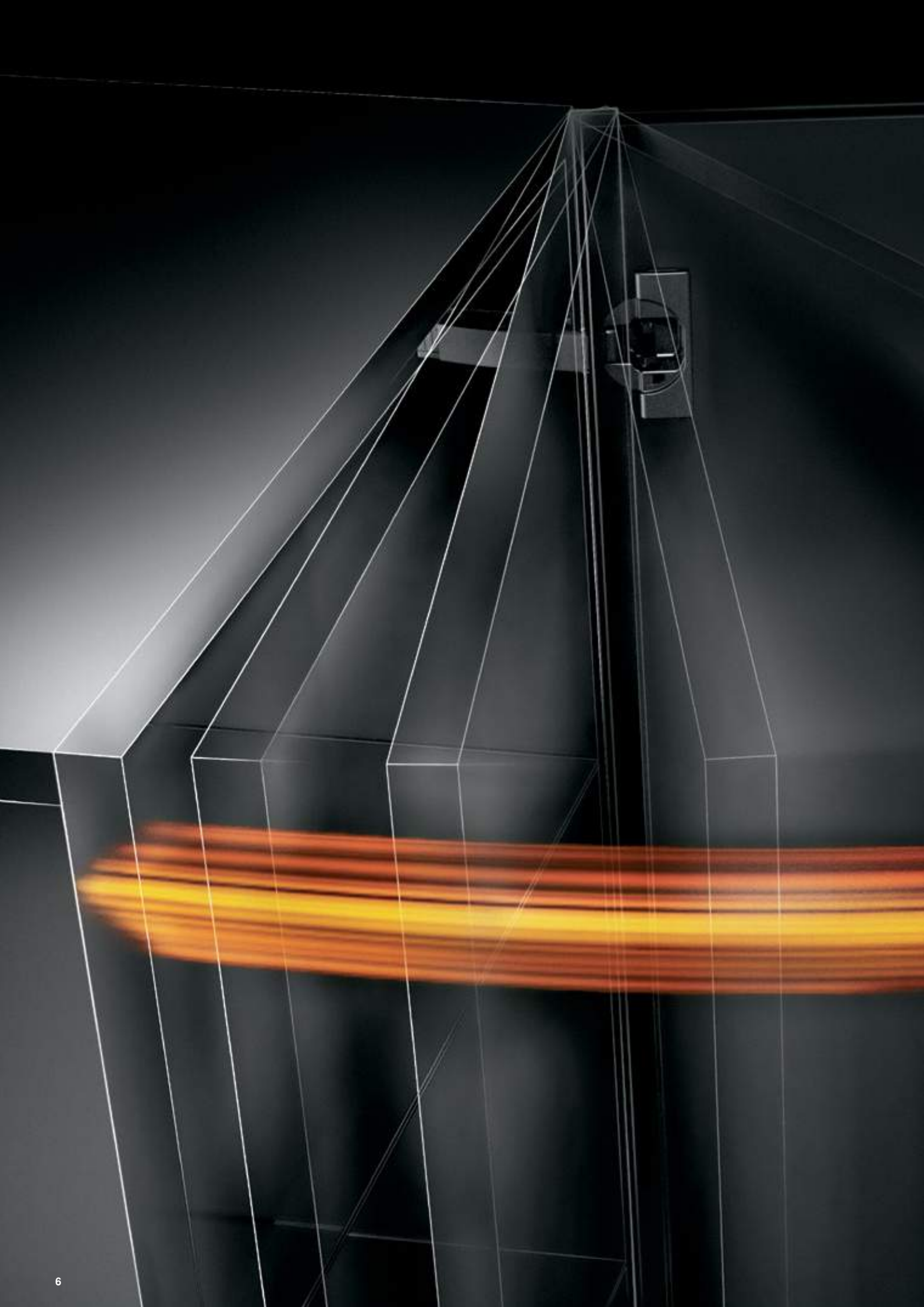

Inspiring perfect motion for every door

Silent and effortless, that's how furniture doors close with BLUMOTION – regardless of the front weight or the closing speed. Thanks to the perfect interplay between the closing mechanism and BLUMOTION, only the lightest touch is required for closing.

 **blum**[®]





Easy deactivation

For high quality of motion with small or light doors, the BLUMOTION function can be easily deactivated on demand.

The hinge with shallow boss drilling depth

The new CLIP top BLUMOTION 107°-hinge impresses with its low drill-hole depth of only 11.5 mm. So the hinge is even suitable for doors as thin as 15 mm.

 **blum**









Fascinating technology beautifully packed

CLIP top BLUMOTION stands for sophisticated technology that is directly integrated in the hinge boss. The elegant product design also visually highlights the high-quality character of CLIP top BLUMOTION.

Versatility in application

CLIP top BLUMOTION 107° opens up new possibilities in various living areas – regardless of the application.

Thanks to integrated BLUMOTION, doors close consistently, smoothly and quietly.



CLIP top BLUMOTION 107° in dual applications



CLIP top BLUMOTION 107° in inset applications



CLIP top BLUMOTION 107° with wide aluminium frames

Assembly made easy

CLIP top BLUMOTION 107° is extremely user friendly. This brings many advantages during assembly and adjustment.

 **blum**





CLIP mechanism

The CLIP mechanism – proven a million times over – stands for simple hinge assembly.

- for all existing CLIP mounting plates
- tool-free fastening of the hinge on the mounting plate thanks to the CLIP assembly method.

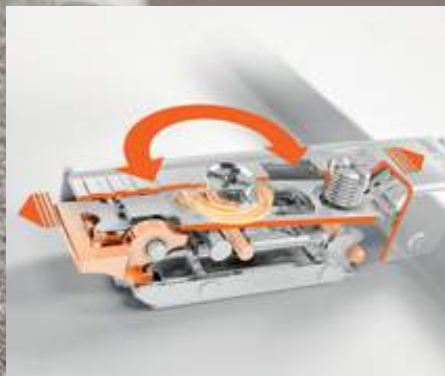

3-dimensional adjustment

CLIP top BLUMOTION enables easy, 3-dimensional adjustment via infinitely variable spiral screw depth adjustment and cam height adjustment for different mounting plates.



Only a few steps

As the BLUMOTION function is integrated into the hinge, no further steps are required after adjustment. BLUMOTION can be easily deactivated according to demand. To do this, simply flip the switch on the hinge boss and close the door once.

CLIP top BLUMOTION 107°



Order specifications

Product



Description

- **CLIP top BLUMOTION with integrated BLUMOTION** (and deactivation option)
- Drill-hole depth 11.5 mm
- Suitable for door thicknesses from 15 mm
- All-metal hinge, nickel plated
- 107° opening angle
- 3-dimensional front adjustment
- Convenient spiral-screw depth adjustment
- Tool-free front to cabinet assembly and removal

Application

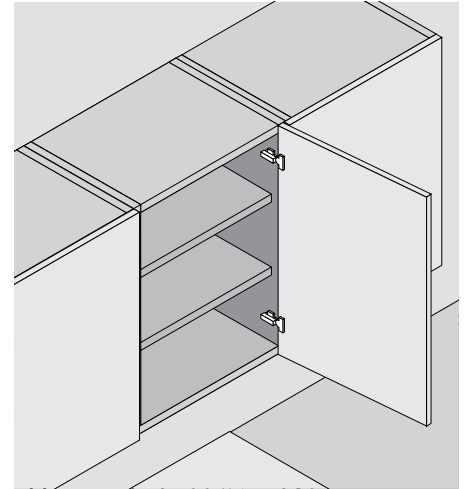

Order specifications

Overlay application			Dual application			Inset application		
	Boss Hinge	Screw-on Part No.		Boss Hinge	Screw-on Part No.		Boss Hinge	Screw-on Part No.
CLIP top BLUMOTION		75B1550	CLIP top BLUMOTION		75B1650	CLIP top BLUMOTION		75B1750
	Boss Hinge	Knock-in Part No.		Boss Hinge	Knock-in Part No.		Boss Hinge	Knock-in Part No.
CLIP top BLUMOTION		75B1580	CLIP top BLUMOTION		75B1680	CLIP top BLUMOTION		75B1780
	Boss Hinge	EXPANDO Part No.		Boss Hinge	EXPANDO Part No.		Boss Hinge	EXPANDO Part No.
CLIP top BLUMOTION		75B158E	CLIP top BLUMOTION		75B168E	CLIP top BLUMOTION		75B178E
	Hinge arm cover cap	Print/Stamp Part No.		Hinge arm cover cap	Print/Stamp Part No.		Hinge arm cover cap	Print/Stamp Part No.
Plain		70.1503	Plain		70.1663	Plain		70.1663
Stamped	Blum	70.1503.BP	Stamped	Blum	70.1663.BP	Stamped	Blum	70.1663.BP
Accessories								
	Hinge boss cover cap	CLIP top BLUMOTION	70T3504		86° Opening angle stop	Plastic	Black	74.1103
	Hinge boss spacing	Boss	Screw-on	1.5 mm				70T3507.21
	Chipboard screws	3.5 x 15 mm	609.1500	3.5 x 17 mm				609.1700

Order specifications

CLIP top BLUMOTION 107°



Hinge dimensions and gap calculation based on factory setting (mounting plate spacing = 0 mm)

Door protrusion at full opening angle

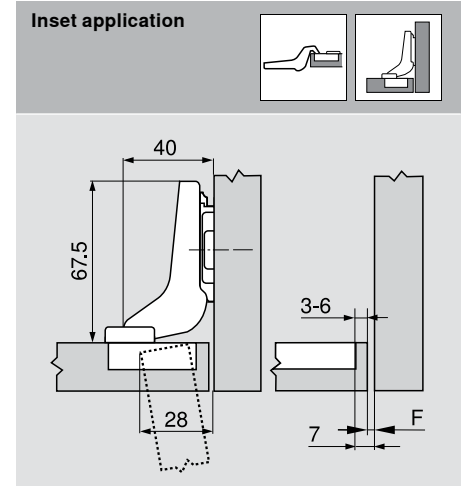
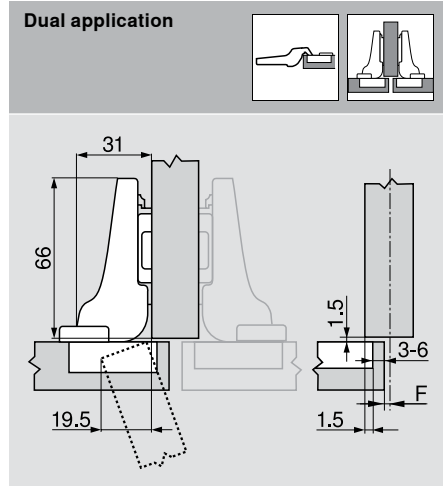
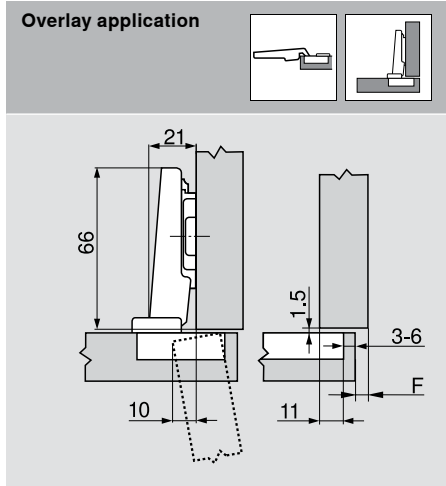

F Gap

Reset fixing position of mounting plate to door thickness + 1.5 mm

Drilling distance

	Front overlay													
	5	6	7	8	9	10	11	12	13	14	15	16	17	
0											3	4	5	6
3							3	4	5	6				
6				3	4	5	6							
9	3	4	5	6										
↑	Mounting plate													

	Front overlay													
	4.5	3.5	2.5	1.5	0.5	0.5	1.5	2.5	3.5	4.5	5.5	6.5	7.5	
0											3	4	5	6
3								3	4	5	6			
6				3	4	5	6							
9	3	4	5	6										
↑	Mounting plate													

	Front overlay							
	-4	-3	-2	-1				
0					3	4	5	6
3								
6								
9								
↑	Mounting plate							

Minimum gap (F) for fronts with a front radius (R = 1 mm) based on the factory setting

Drilling distance TB	Front thickness FD														
	15	16	18	19	20	21	22	24	26	28	30	31	32		
3	0.4	0.5	1.0	1.3	1.6	2.1	2.7	4.3	A trial application is recommended						
4	0.4	0.5	0.9	1.2	1.5	2.0	2.5	3.9							
5	0.3	0.5	0.9	1.2	1.4	1.8	2.3	3.6							
6	0.3	0.5	0.8	1.1	1.4	1.7	2.2	3.3							
-															
Additional for + 2 mm side adjustment															
	+ 0.1	+ 0.1	+ 0.2	+ 0.2	+ 0.3	+ 0.3	+ 0.3	+ 0.3							

Adjustment areas

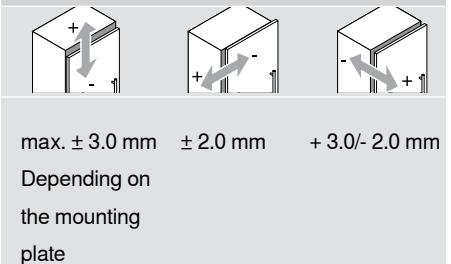

Screw-on assembly

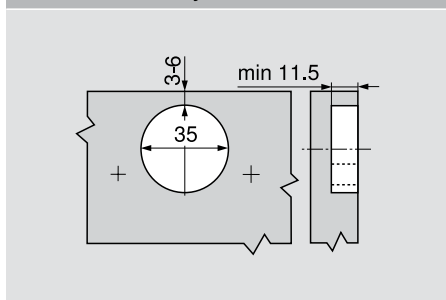

Knock-in assembly

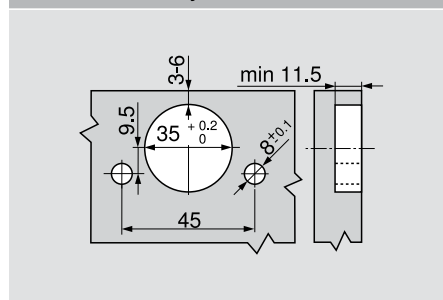

Hinge boss dimensions

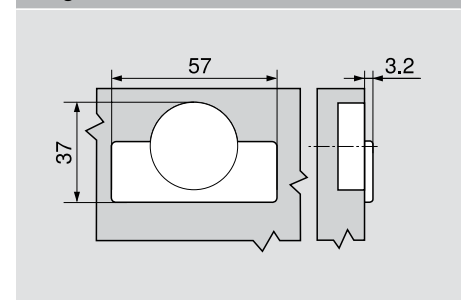

Everything for that familiar, precise assembly

Blum assembly aids help you to assemble Blum products as efficiently and simply as possible. So making high-quality furniture becomes even more convenient and precise. For the assembly of CLIP top BLUMOTION 107°, special templates and jigs are available.



ECODRILL

Handy solution: precision for the Blum hinge drilling pattern

- Hand-held tool for drilling accurate Blum hinge drilling patterns
- Hand drill required
- Drilling distance from 2 to 8 mm
- Assembly on the marking line
- Robust and compact design



Components

1 x drilling template, 2 x dowel drill bits (Ø 8 mm), 1 x fitting drill bit (Ø 35 mm), 2 x Torx bits

Part no. **M31.1000**

Drilling template for hinge systems

Transferring exact fixing positions

- Template for the transfer of measurements for hinge and mounting plate fixing positions
- Template for the transfer of measurements from door to cabinet and from cabinet to door
- Can be used with assembled and unassembled cabinets
- Adjustable stop for various front overlays
- The calibration makes it easy to adjust the template



Components

1 x 1000 mm rail, 2 x templates with marking pin, 1 x stop for unattached cabinet side

Part no. **65.7500.03**

Drilling template for hinges

Create, fix and precisely pre-drill all fixing positions

- Drill the side fixing positions for hinges (Ø 8 mm or Ø 2.5 mm)
- Drilling the fixing positions for mounting plates/adaptor plates (BLUMOTION/TIP-ON for doors)
- Assembly on marking line possible

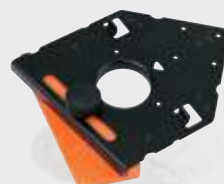

Components

1 x drilling template for hinges (Ø 2.5 mm) for screw-on boss

Part no. **65.055A**

1 x drilling template for hinges (Ø 8 or Ø 2.5 mm) for EXPANDO and knock-in dowels, including reducing bush (Ø 8 to Ø 2.5 mm) and drilling depth stop (Ø 8 mm)

Part no. **65.059A**

Template

Drilling on the marking line and transferring dimensions

- Drilling the fixing positions for mounting plates/adaptor plates (BLUMOTION/TIP-ON for doors)
- Transfer of measurements from door to cabinet
- If mounting plate fixing positions are standard throughout, then it is possible to screw several templates onto a wooden strip
- Assembly on the marking line



Components

1 x template	Part no.	65.5300*
--------------	----------	----------

Knock-in tool for hinges/mounting plates

Reliable hinge/mounting plate insertion

- Knock-in tool for hinges: Enables you to knock-in all CLIP top BLUMOTION, CLIP top, CLIP and MODUL hinges
- Knock-in tool for mounting plates: Enables you to knock-in horizontal and cruciform mounting plates

i Do not use a hammer to insert the hinge into the drill hole.



Components

1 x knock-in tool for hinges	Part no.	ZME.0710
1 x knock-in tool for horizontal mounting plate	Part no.	ZME.0730
1 x knock-in tool for horizontal and cruciform mounting plate	Part no.	65.6100

Insertion ram for hinges

Blum drilling and insertion machines

- Enables you to knock-in all CLIP top BLUMOTION, CLIP top, CLIP and MODUL hinges



Components

1 x insertion ram for hinges	Part no.	MZM.0040
------------------------------	----------	----------

Blum

Founded over 60 years ago by Julius Blum, today Blum is an internationally active family-owned company. Its strategic business segments include lift, hinge and pull-out systems. All our product developments focus on perfecting motion.

www.blum.com

 **blum**





Blum in Austria and around the world

The company has seven plants in Vorarlberg, Austria, additional production sites in Poland, the USA and Brazil and 27 subsidiaries/representative offices. Blum supplies more than 120 markets. The Blum Group employs 6.600 people in total, 5.000 of whom work in Vorarlberg.



Global customer benefits

"Whether manufacturer, distributor, fitter or kitchen user – everybody should personally enjoy the benefits of Blum products" – that is Blum's philosophy on global customer benefits.



Innovations

To support customers with innovative fittings solutions and secure long-term success for the company, we need to consistently invest in research and development, in plants and facilities and in employee training. With more than 1200 registered trademarks around the world, Blum is one of Austria's most innovative companies.



Quality

At Blum, the comprehensive concept of quality does not only apply to products. Services and our cooperation with customers and partners should also meet the same quality requirements.



Environment

At Blum, we believe that responsible ecological behaviour has long-term economic benefits. The longevity of products is just one of many important aspects. Other important measures include the use of environmentally friendly processes, the intelligent use of materials and prudent energy management.

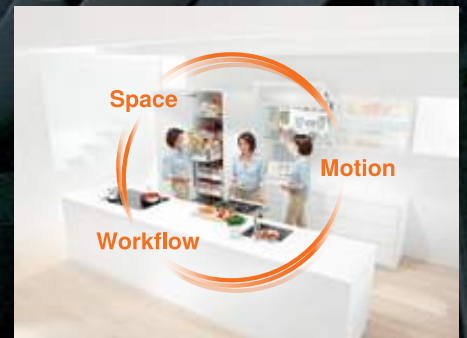

DYNAMIC SPACE

Good workflows, optimum use of storage space and high quality of motion are important features of a practical kitchen. Blum's ideas for practical kitchen are designed to bring function, convenience and ergonomics to furniture interiors.



Blue International Co.,Ltd.
8,10,12 Soi Ramkhamhaeng 26/1
Ramkhamhaeng
Rd., Huamark, Bangkok
BANGKOK 10240
THAILAND
Tel: +66 2 374 7755
Fax: +66 2 374 9176
E-Mail: info@blue-inter.com
www.blum.com

Julius Blum GmbH
Beschlagefabrik
6973 Hochst, Austria
Tel.: +43 5578 705-0
Fax: +43 5578 705-44
E-Mail: info@blum.com
www.blum.com

