

# Hinge systems



- ▶ CLIP top BLUMOTION | CLIP top – hinges
- ▶▶ Standard application

Hinge systems

## CLIP 100° hinge

Webcode

DQDGA



- CLIP with or without closing mechanism (spring)
- 100° opening angle
- 3-dimensional front adjustment
- Tool-free door to cabinet assembly and removal
- With INSERTA tool-free hinge to door assembly

### Application

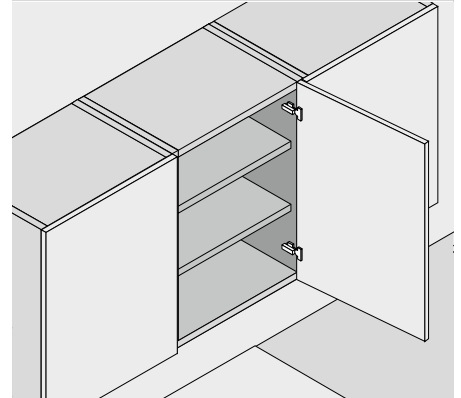

### Order information

#### Overlay application

Boss		INSERTA	
Hinge	Spring	Colour	Part no.
CLIP	●	NI	71M2590B
●	With spring		
○	Unsprung		
○	NI	Nickel plated	

Boss		Screw-on	
Hinge	Spring	Colour	Part no.
CLIP	●	NI	71M2550
CLIP	○	NI	70M2550.TL

Boss		Knock-in	
Hinge	Spring	Colour	Part no.
CLIP	●	NI	71M2580
CLIP	○	NI	70M2580.TL

#### Accessories

BLUMOTION 973A	
Version	Part no.
Clip on	973A0500.01

Hinge arm cover cap			
Print   Stamp	Logo	Colour	Part no.
Plain	–	NI	90M2503
Stamped	Blum	NI	90M2503.BP

#### Dual application

Boss		INSERTA	
Hinge	Spring	Colour	Part no.
CLIP	●	NI	71M2690B
●	With spring		
○	Unsprung		
○	NI	Nickel plated	

Boss		Screw-on	
Hinge	Spring	Colour	Part no.
CLIP	●	NI	71M2650
CLIP	○	NI	70M2650.TL

Boss		Knock-in	
Hinge	Spring	Colour	Part no.
CLIP	●	NI	71M2680
CLIP	○	NI	70M2680.TL

#### Accessories

BLUMOTION 973A	
Version	Part no.
Clip on	973A0600

Hinge arm cover cap			
Print   Stamp	Logo	Colour	Part no.
Plain	–	NI	94M3603
Stamped	Blum	NI	94M3603.BP

#### Inset application

Boss		INSERTA	
Hinge	Spring	Colour	Part no.
CLIP	●	NI	71M2790B
●	With spring		
○	Unsprung		
○	NI	Nickel plated	

Boss		Screw-on	
Hinge	Spring	Colour	Part no.
CLIP	●	NI	71M2750
CLIP	○	NI	70M2750.TL

Boss		Knock-in	
Hinge	Spring	Colour	Part no.
CLIP	●	NI	71M2780
CLIP	○	NI	70M2780.TL

#### Accessories

BLUMOTION 973A	
Version	Part no.
Clip on	973A0700

Hinge arm cover cap			
Print   Stamp	Logo	NI	Part no.
Plain	–	NI	94M3603
Stamped	Blum	NI	94M3603.BP

### Accessories – general

TIP-ON for doors		
Version	Spring	Part no.
Short version	○	956.1004
Extended version	○	956A1004
Extended version	●	956A1006
●	With spring	
○	Unsprung	

Insertion ram		
Colour	Material	Part no.
Orange	Nylon	MZM.0040

Chipboard screws		
Ø (mm)	Length (mm)	Part no.
3.5	15	609.1500
3.5	17	609.1700

CLIP 100° hinge

Webcode  
DQDGA

Planning

Hinge dimensions and gap calculation based on factory setting (mounting plate spacing = 0 mm)

Hinge and front protrusion at full opening angle

Overlay application

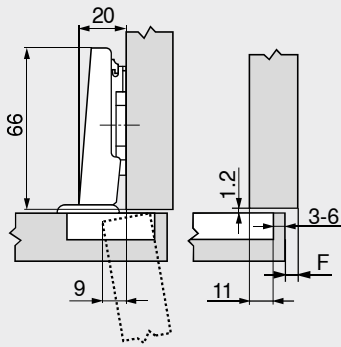
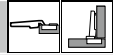

F Gap

Dual application

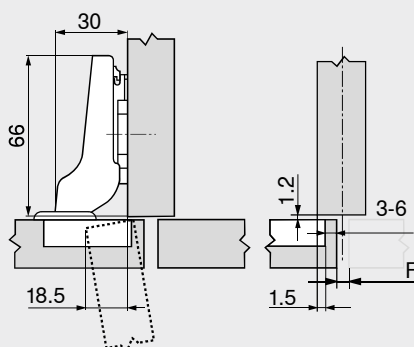
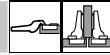

Inset application

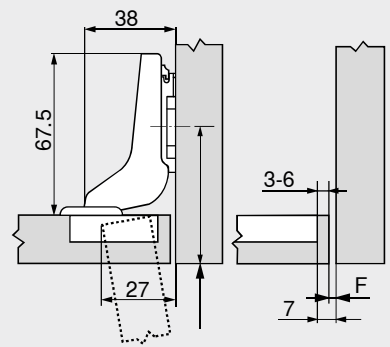
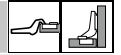

Set mounting plate back by door thickness +1.2 mm

Drilling distance TB

MD	Front overlay FA (mm)												
	5	6	7	8	9	10	11	12	13	14	15	16	17
0										3	4	5	6
3										3	4	5	6
6					3	4	5	6					
9	3	4	5	6									

MD Mounting plate spacing (mm)

MD	Front overlay FA (mm)													
	-4.5	-3.5	-2.5	-1.5	-0.5	0.5	1.5	2.5	3.5	4.5	5.5	6.5	7.5	
0											3	4	5	6
3											3	4	5	6
6											3	4	5	6
9	3	4	5	6										

MD Mounting plate spacing (mm)

MD	Front overlay FA (mm)						
	-7	-6	-5	-4	-3	-2	-1
0							
3							
6							
9							

MD Mounting plate spacing (mm)

Minimum gap F for fronts with a front radius (R = 1 mm) based on the factory setting

Drilling distance TB (mm)	Front thickness FD (mm)											
	16	18	19	20	21	22	24	26	28	30	31	32
3	0.3	0.5	0.7	1.0	1.3	1.6	3.3	Δ	Δ	Δ	Δ	Δ
4	0.3	0.5	0.7	1.0	1.2	1.6	3.2	Δ	Δ	Δ	Δ	Δ
5	0.3	0.5	0.7	0.9	1.2	1.5	2.6	Δ	Δ	Δ	Δ	Δ
6	0.3	0.5	0.7	0.9	1.1	1.4	2.4	Δ	Δ	Δ	Δ	Δ
Additional for +2 mm side adjustment												
	+0.1	+0.3	+0.3	+0.4	+0.4	+0.5	+0.4					

Δ In these cases a trial is recommended

Adjustment

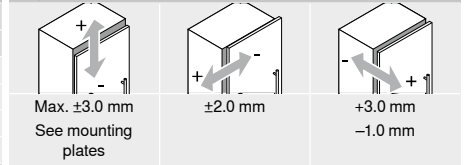

Screw-on

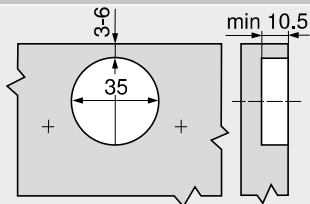

INSERTA | knock-in

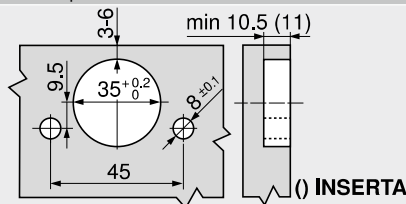

Hinge boss dimensions

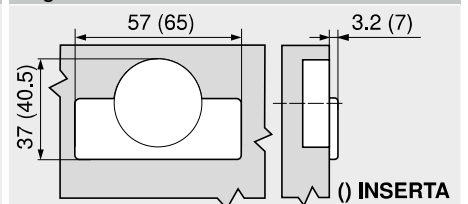

Page instructions

Overview – CLIP top BLUMOTION   CLIP top – hinges	75
Mounting plates	156
Accessories – hinge arm cover cap	164
Accessories – general	166
Overview – BLUMOTION for doors	171

Overview – TIP-ON for doors	185
Overview – assembly devices	561
More technical details	662

Assembly, removal and adjustment

Short-URL  
[www.blum.com/a210](http://www.blum.com/a210)

