

# Hinge systems



- ▶ CLIP top BLUMOTION | CLIP top – hinges
- ▶▶ Standard application

Hinge systems

## 107° hinge



- For front thicknesses starting from 15 mm
- CLIP top BLUMOTION with integrated BLUMOTION (with deactivation option)
- CLIP top with or without closing mechanism (spring)
- 107° opening angle
- 3-dimensional front adjustment
- Convenient spiral-tech depth adjustment
- Tool-free door to cabinet assembly and removal
- With INSERTA tool-free hinge to door assembly

Webcode

DQDFZY

### Application

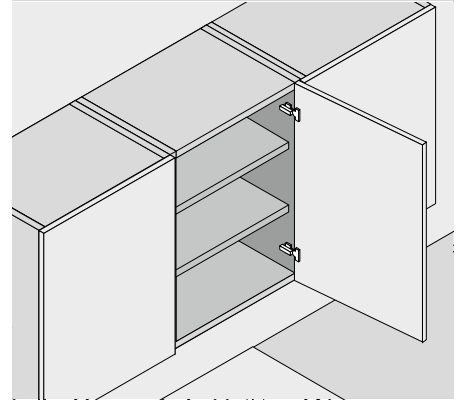

### Order information

#### Overlay application

Boss		INSERTA		
Hinge	Spring	Colour	Part no.	
CLIP top	●	NI	75T1590B	
CLIP top	○	NI	74T1590BTL	
● With spring		NI Nickel plated		
○ Unsprung		ONS Onyx black		

Boss		Screw-on		
Hinge	Spring	Colour	Part no.	
CLIP top	●	NI   ONS	75B1550	
CLIP top	●	NI	75T1550	
CLIP top	○	NI	74T1550.TL	

Boss		Knock-in		
Hinge	Spring	Colour	Part no.	
CLIP top	●	NI	75B1580	
CLIP top	●	NI	75T1580	

Print   Stamp		Logo	Colour	Part no.
Plain	–	NI   ONS		70.1503
Stamped	Blum	NI   ONS		70.1503.BP

#### Dual application

Boss		INSERTA		
Hinge	Spring	Colour	Part no.	
CLIP top	●	NI	75T1690B	
CLIP top	○	NI	74T1690BTL	
● With spring		NI Nickel plated		
○ Unsprung		ONS Onyx black		

Boss		Screw-on		
Hinge	Spring	Colour	Part no.	
CLIP top	●	NI   ONS	75B1650	
CLIP top	●	NI	75T1650	
CLIP top	○	NI	74T1650.TL	

Boss		Knock-in		
Hinge	Spring	Colour	Part no.	
CLIP top	●	NI	75B1680	
CLIP top	●	NI	75T1680	

Print   Stamp		Logo	Colour	Part no.
Plain	–	NI   ONS		70.1663
Stamped	Blum	NI		70.1663.BP

#### Inset application

Boss		INSERTA		
Hinge	Spring	Colour	Part no.	
CLIP top	●	NI	75T1790B	
CLIP top	○	NI	74T1790BTL	
● With spring		NI Nickel plated		
○ Unsprung		ONS Onyx black		

Boss		Screw-on		
Hinge	Spring	Colour	Part no.	
CLIP top	●	NI   ONS	75B1750	
CLIP top	●	NI	75T1750	
CLIP top	○	NI	74T1750.TL	

Boss		Knock-in		
Hinge	Spring	Colour	Part no.	
CLIP top	●	NI	75B1780	
CLIP top	●	NI	75T1780	

Print   Stamp		Logo	Colour	Part no.
Plain	–	NI   ONS		70.1663
Stamped	Blum	NI		70.1663.BP

### Note

A trial application is recommended when combining CLIP top BLUMOTION hinges and CLIP top hinges with springs on small, light fronts up to 300 mm wide. Combining these is not recommended for wider fronts.

### Accessories – general

Opening angle stop		
Opening angle	Colour	Part no.
86°	Black	74.1103

TIP-ON for doors		
Version	Spring	Part no.
Short version	○	956.1004
Extended version	○	956A1004
Extended version	●	956A1006
● With spring	○ Unsprung	

Hinge boss cover cap		
Hinge	Colour	Part no.
CLIP top	NI   ONS	70T3504
CLIP top	NI	70T1504
NI Nickel plated	ONS Onyx black	

Hinge boss spacing		
Hinge	Spacing (mm)	Part no.
CLIP top	1.5	70T3507.21
BLUMOTION		

Chipboard screws		
Ø (mm)	Length (mm)	Part no.
3.5	15	609.1500
3.5	17	609.1700

Insertion ram		
Colour	Material	Part no.
Orange	Nylon	MZM.0040

107° hinge

Webcode  
DQDFZY

Planning

Hinge dimensions and gap calculation based on factory setting (mounting plate spacing = 0 mm)

Hinge and front protrusion at full opening angle

Overlay application

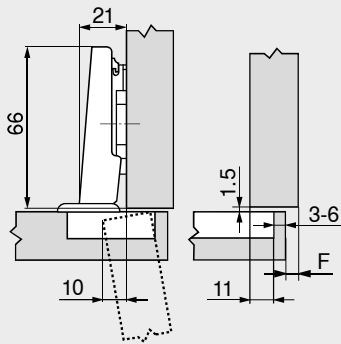
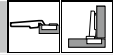

F Gap

Dual application

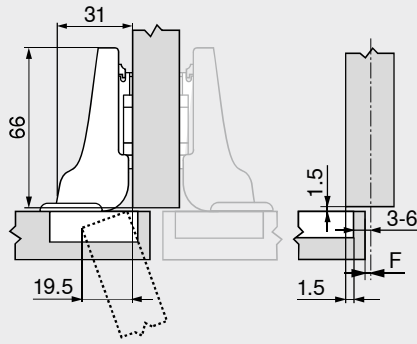
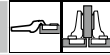

Inset application

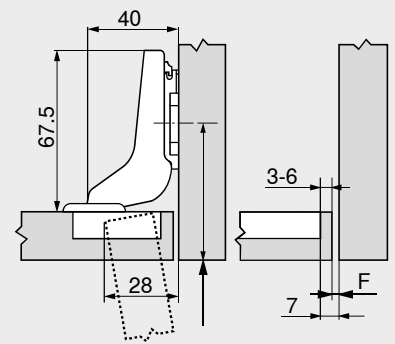
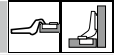

Set mounting plate back by door thickness +1.5 mm

Drilling distance TB

MD	Front overlay FA (mm)																	
	5	6	7	8	9	10	11	12	13	14	15	16	17					
0														3	4	5	6	
3															3	4	5	6
6																		
9	3	4	5	6														

MD Mounting plate spacing (mm)

MD	Front overlay FA (mm)																	
	-4.5	-3.5	-2.5	-1.5	-0.5	0.5	1.5	2.5	3.5	4.5	5.5	6.5	7.5					
0																		
3																		
6																		
9	3	4	5	6														

MD Mounting plate spacing (mm)

MD	Front overlay FA (mm)						
	-7	-6	-5	-4	-3	-2	-1
0							
3							
6							
9							

MD Mounting plate spacing (mm)

Minimum gap F for fronts with a front radius (R = 1 mm) based on the factory setting

Drilling distance TB (mm)	Front thickness FD (mm)											
	15	16	18	19	20	21	22	24	26	28	30	32
3	0.4	0.5	1.0	1.3	1.6	2.1	2.7	4.3	Δ	Δ	Δ	Δ
4	0.4	0.5	0.9	1.2	1.5	2.0	2.5	3.9	Δ	Δ	Δ	Δ
5	0.3	0.5	0.9	1.2	1.4	1.8	2.3	3.6	Δ	Δ	Δ	Δ
6	0.3	0.5	0.8	1.1	1.4	1.7	2.2	3.3	Δ	Δ	Δ	Δ

Additional for +2 mm side adjustment  
+0.1 +0.1 +0.2 +0.2 +0.3 +0.3 +0.3 +0.3

Δ In these cases a trial is recommended

Adjustment

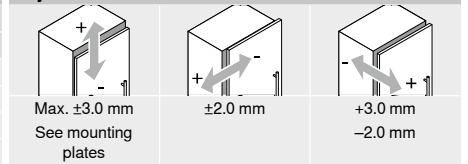

Screw-on

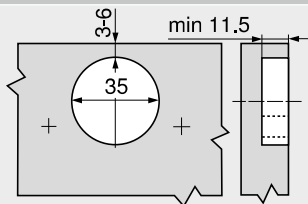

INSERTA | knock-in

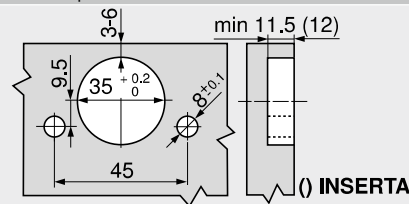

Hinge boss dimensions

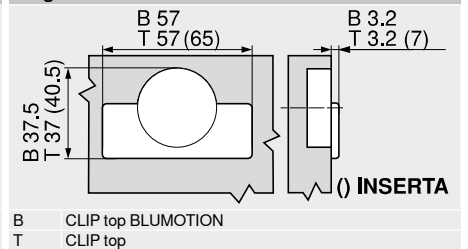

Page instructions

Overview – CLIP top BLUMOTION   CLIP top – hinges	75
Mounting plates	156
Accessories – hinge arm cover cap	164
Accessories – general	166
Overview – BLUMOTION for doors	171

Overview – TIP-ON for doors	185
Overview – assembly devices	561
More technical details	662

Assembly, removal and adjustment

Short-URL  
[www.blum.com/a210](http://www.blum.com/a210)

