

New Challenge for creation—NOK GROUP



NOK

● Cat. No. 035E-10-2001

PACKINGS

HYDRAULIC SEALING SYSTEMS

NOK CORPORATION



PACKINGS

HYDRAULIC SEALING SYSTEMS

NOK CORPORATION

HYDRAULIC SEALING SYSTEMS

CONTENTS

A	WHAT ARE NOK HYDRAULIC SEALING SYSTEMS	A-1 ~ A-6
B	TYPES AND MAIN FEATURES OF NOK PACKINGS	B-1 ~ B-8
C	COMPOSITION OF NOK PACKINGS	C-1 ~ C-6
D	SELECTING NOK PACKINGS	D-1 ~ D-12
E	APPLICATION EXAMPLES OF NOK PACKINGS	E-1 ~ E-18
F	DIMENSION TABLES FOR NOK PACKINGS	F-1 ~ F-146
G	HANDLING AND INSTALLATION OF NOK PACKINGS	G-1 ~ G-12
H	WHEN LEAKAGE OCCURS	H-1 ~ H-12
I	TECHNICAL DATA	I-1 ~ I-14
J	REFERENCE MATERIAL	J-1 ~ J-21



WHAT ARE NOK HYDRAULIC SEALING SYSTEMS?

**What are hydraulic
sealing systems? _____ A-2**

What are lip packings? _____ A-3

What are squeeze packings? _____ A-4

How do packings seal? _____ A-5

Lubrication characteristics _____ A-6

A. WHAT ARE NOK HYDRAULIC SEALING SYSTEMS?

Hydraulic Sealing Systems

are general terms describing sealing systems (seals) used for moving parts (usually with reciprocal movement) of hydraulic equipment. Different types of seals may be combined, depending on the application.

Different types of seals are classified...

below according to the application, form and material. Lip packings are most frequently used for reciprocal moving parts. An application example for a hydraulic cylinder is shown in Fig. A-1.

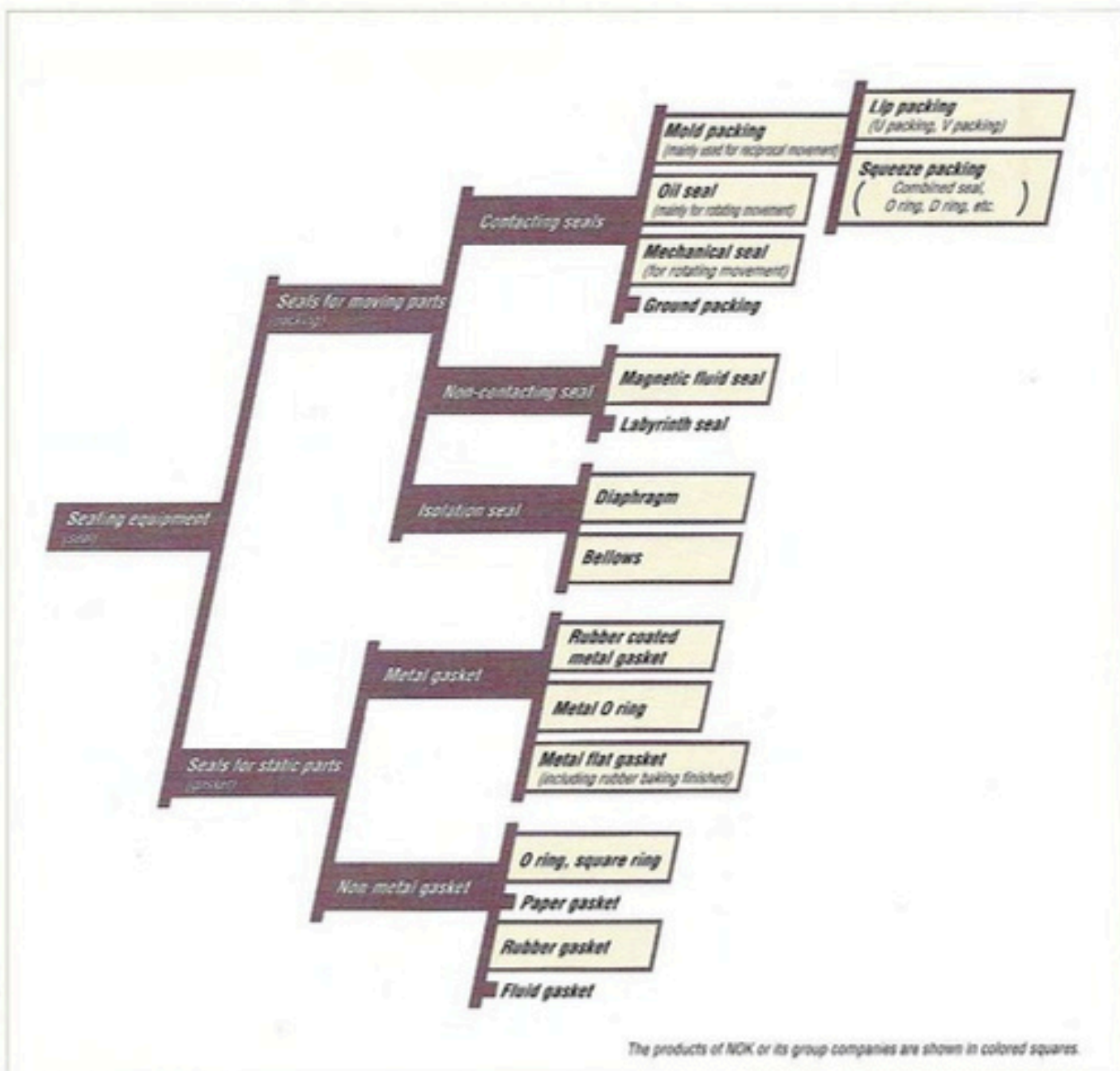

In this catalogue

Wide application examples of seals for hydraulic equipment, especially mold packings including oil seals and related products, are introduced. Separate catalogs are available for oil seals and O-rings. Please ask for more information.

<Fig. A-1> Application example for hydraulic cylinder

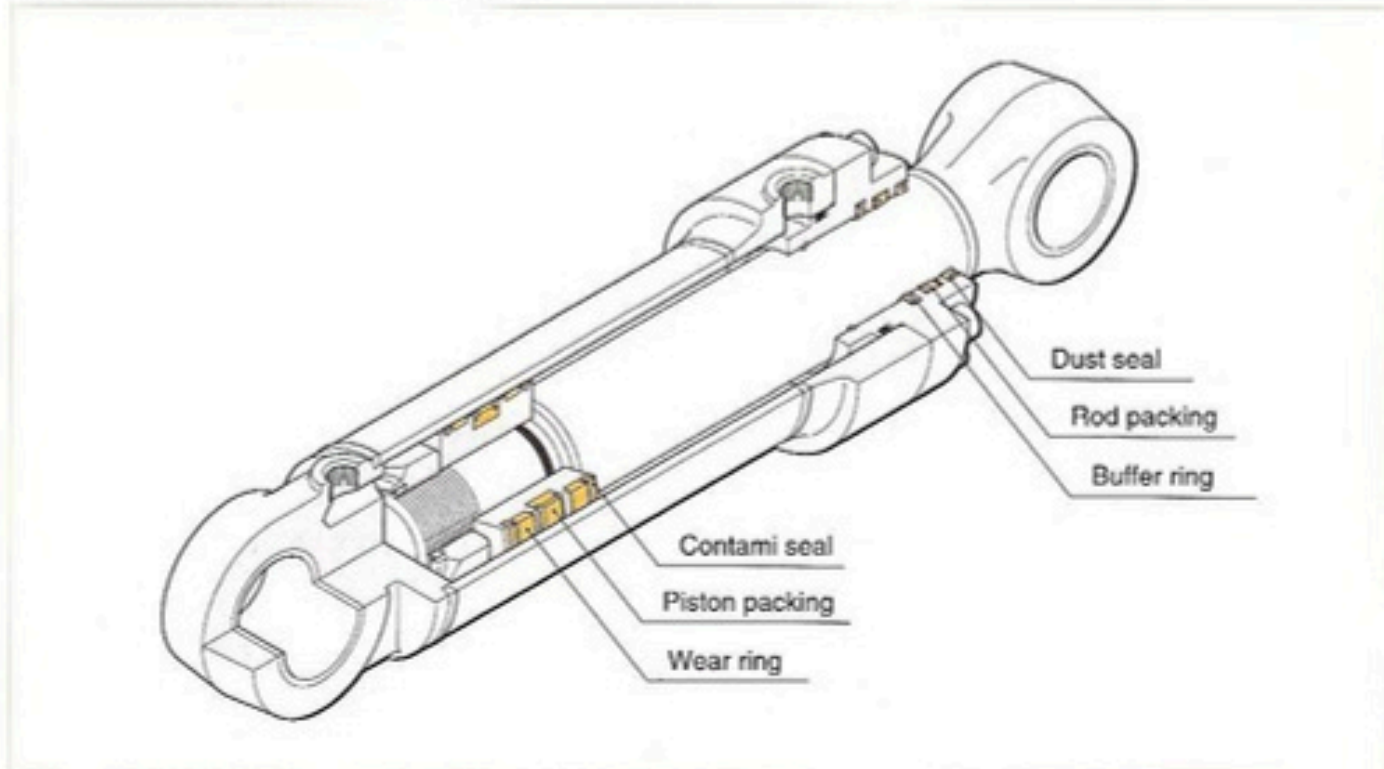

What are lip packings?

U packings are used as an example of description. As its name suggests, a U packing is a general term describing a packing with a U-shaped groove as shown in Fig. A-2. This packing has an inner lip "A" and outer lip "B".

<Fig. A-2> U packing

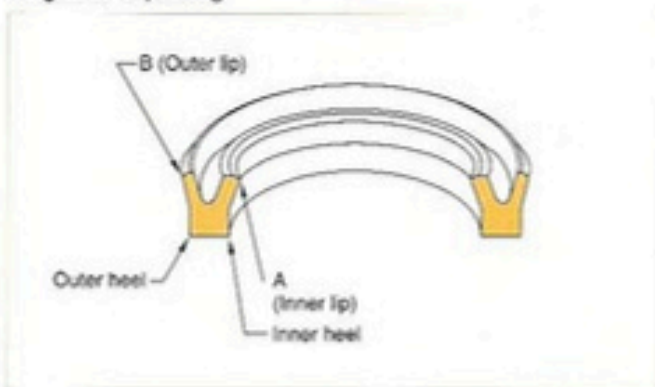

The inner heel and outer heel are shown on the other end. Fig. A-3 shows a U packing deformed by interference when fitted into the installation groove, which makes the lip contact with the rod. When fluid pressure (oil pressure) is added, the heel of the packing becomes deformed so the complete sliding surface is intact with the rod surface. The condition of contacting pressure distribution of the lip and heel is closely related with the sealing characteristics of the packing.

The relationship between sealing characteristics and contacting pressure distribution is described on page A-5.

<Fig. A-3> Contacting pressure distribution of U packing

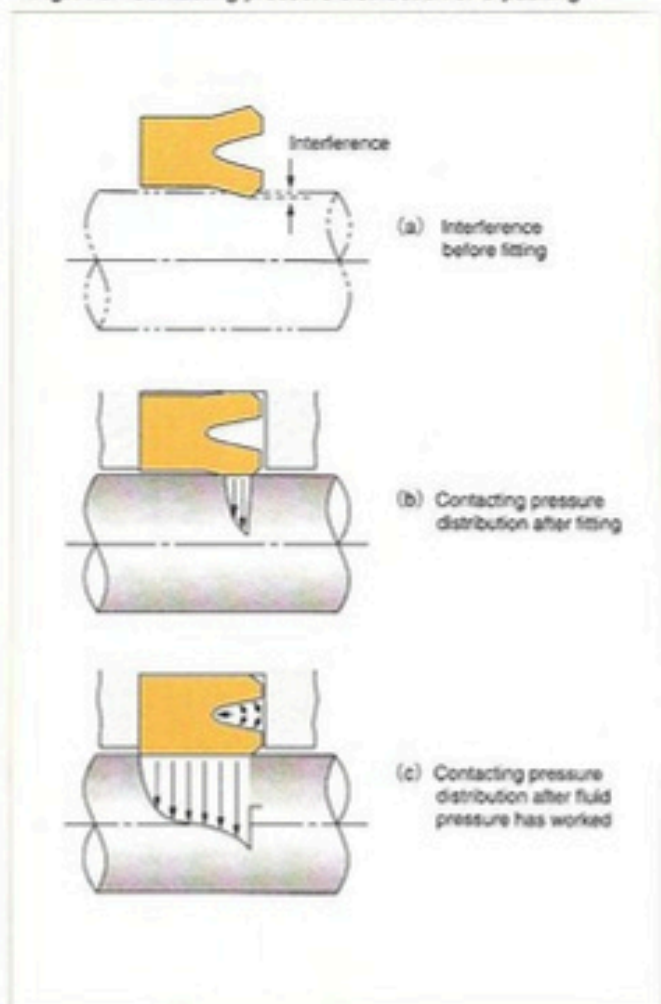

What are squeeze packings?

This type of packing applies a rubber-like elastic object onto the sealed surface.

<Fig. A-4> O ring

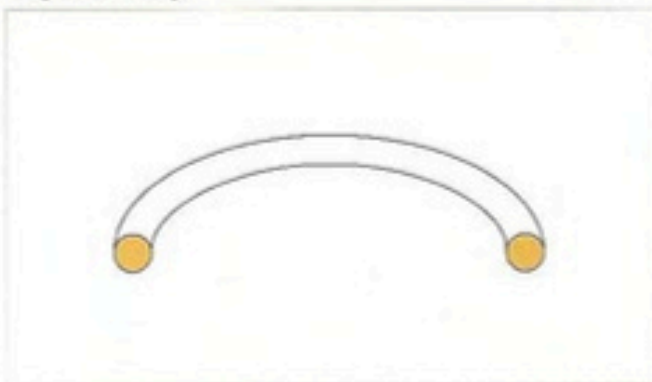

An O-ring (Fig. A-4) with an O-shaped profile is a typical squeeze packing. Significant pressure on the sealing surface is required to compress and deform the profile for sealing. For this reason, significant frictional resistance and high-sliding frictional heat is created resulting in a short life of the packing. To reduce sliding frictional resistance and frictional heat, the compression and deformation ratio of the O-ring should be decreased, which will, however, reduce the sealing ability.

<Fig. A-5> Example of combined seal

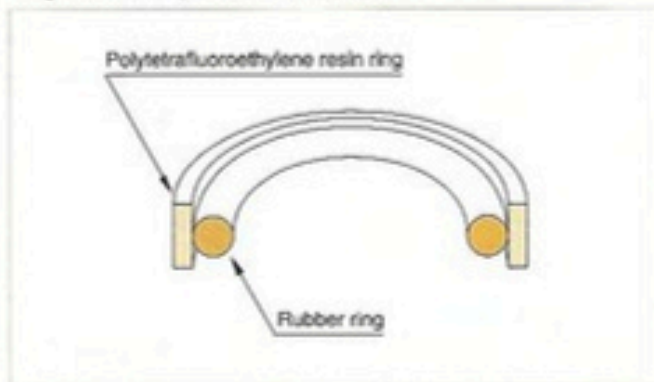

To decrease friction, a combined seal (called a slipper seal) has been developed with low-friction polytetra-fluoro-ethylene resin (PTFE) on the sliding surface (Fig. A-5).

Compared to the lip packing, the combined seal has a lower sealing ability but offers lower sliding resistance. Because of these characteristics, this seal is mainly used as a piston packing for hydraulic cylinders.

For effective application, hydraulic sealing systems should combine various sealing devices most appropriate for specific operating conditions and usage.

How do packings seal?

By what means do packings for reciprocal movement seal hydraulic fluid? A U packing serves as a good example to illustrate sealing capability.

As shown in Fig. A-6, when the rod moves to the right, the U packing is contacting with the rod under pressure distribution created by the peak pressure (P_1 max) that is higher than the inner pressure (P_1). Thickness of the fluid/oil passing through the packing becomes thinner as the maximum contacting pressure gradient of the hydraulic pressure of the pressure distribution (dp/dx) max.P becomes greater.

Conversely, when the rod moves to the left by the inner pressure (P_2) on the U packing (Fig. A-7), the thickness of the fluid/oil passing through the packing depends on maximum contacting pressure gradient of the atmospheric pressure (dp/dx) max.M.

To reduce friction, a fluid/oil film on the sliding surface of the packing is necessary. NOK designs packings with well-balanced contacting pressure distribution to form optimum fluid/oil film on the sliding surface.

<Fig. A-6> Contacting pressure distribution (pushing stroke)

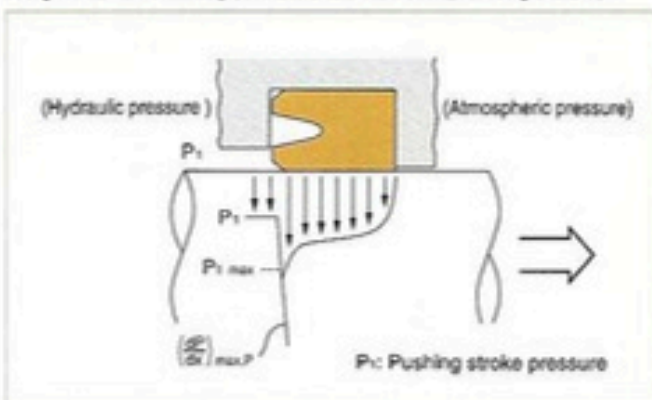

<Fig. A-7> Contacting pressure distribution (pulling stroke)

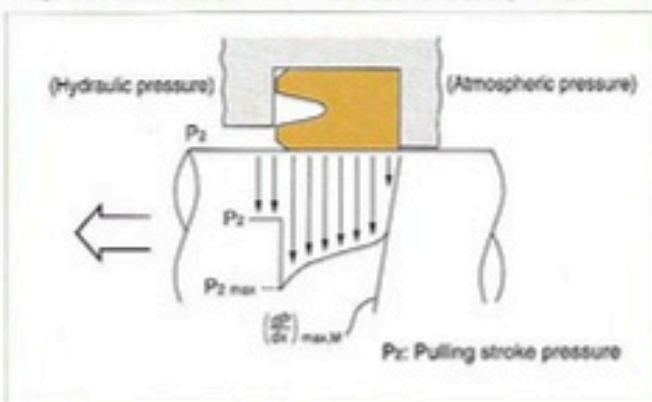

The minimum oil film thickness of the sliding surface depends on the maximum contacting pressure gradient, speed, and oil viscosity, and can be obtained from the formula (1) below.

$$h = \sqrt{\frac{8 \mu U}{9 |dp/dx|_{max}}} \quad \dots\dots\dots (1)$$

μ : Oil viscosity
(Pa·s [kgf·s/cm²])

U : Speed (cm/s)

$|dp/dx|_{max}$: Absolute value of the maximum contacting pressure gradient
(Pa/cm [kgf/cm²])

In the case of a hydraulic cylinder, the thickness of the fluid/oil film created at the pushing stroke (when the rod extends) (h_P) and at the pulling stroke (when the rod compresses) (h_M) can be obtained respectively by the formula (2) and (3).

$$h_P = \sqrt{\frac{8 \mu U_P}{9 |dp/dx|_{max,P}}} \quad \dots\dots\dots (2)$$

$$h_M = \sqrt{\frac{8 \mu U_M}{9 |dp/dx|_{max,M}}} \quad \dots\dots\dots (3)$$

U_P : Speed of the pushing stroke (cm/s)

U_M : Speed of the pulling stroke (cm/s)

$|dp/dx|_{max,P}$: Maximum contacting pressure gradient of hydraulic pressure at the pushing stroke
(Pa/cm [kgf/cm²])

$|dp/dx|_{max,M}$: Maximum contacting pressure gradient of atmospheric pressure at the pulling stroke
(Pa/cm [kgf/cm²])

Therefore, if the speed of both the pushing and pulling stroke is the same ($U_P=U_M$), $h_P \geq h_M$ is the condition for sealing and the packing satisfying the formula below

$$|dp/dx|_{max,P} \geq |dp/dx|_{max,M}$$

can be regarded to have a good sealing performance.

Lubrication characteristics

One of the most important features of a packing for reciprocal movement is to have low friction on the sliding surface to assure long life.

To reduce friction, proper lubricant (oil film) is necessary for the sliding surface of the packing for reciprocal movement. How do lubrication characteristics change according to operating conditions?

To understand globally the lubricating requirements of a packing's sliding surface, it is necessary to know dynamic friction characteristics when pressure, speed and fluid oil viscosity effecting the surface have changed.

An example of a U packing for a hydraulic cylinder rod helps explain this. The relationship between non-dimensional characteristics value G , that is determined by the form of U packings and its operating condition and the friction coefficient f , is determined in figure A-8. The range where the friction coefficient has a positive gradient is described as fluid lubrication in the lubrication theory. Within this range, the rod and the packing are in contact with each other through oil film, assuring a long packing life without wearing, even if a relative reciprocal movement occurs.

Within the range where the coefficient f has a negative gradient, the oil film between the packing and the rod is destroyed. This range is called the non-fluid lubrication area.

<Figure A-8> Example of non-dimensional characteristics graph (U packing)

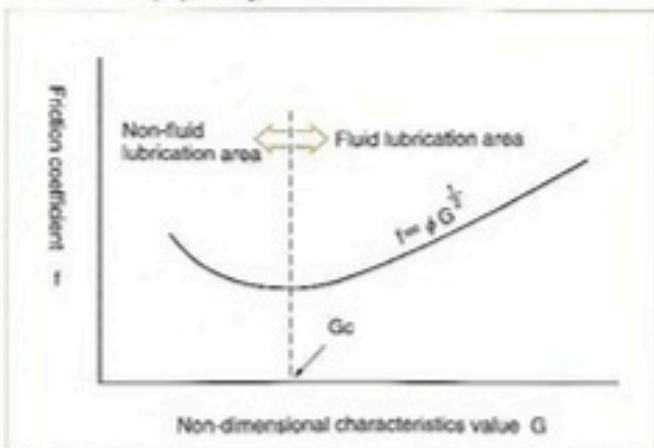

Where,

- f : Friction coefficient
- ϕ : Constant that is determined by the condition of oil film
- G : Non-dimensional characteristics value ($= \mu dU / Pr$)
- Pr : Compression force of packing (N [kgf])
- μ : Viscosity of fluid oil (Pa·s [kgf·s/cm²])
- d : Rod diameter (cm)
- U : Speed (cm/s)

Switching point G_c of the non-dimensional characteristics value where the fluid lubrication area shifts to the non-fluid lubrication area varies depending on the maximum contacting pressure gradient of the packing and the surface roughness of the rod and can be obtained by the formula (4) below.

$$G_c = \frac{9}{8\pi} \left(\frac{b}{\bar{p}} \right) \left| \frac{dp}{dx} \right|_{\max} \left(\frac{R_{\max}}{b} \right)^2 \quad \dots (4)$$

Where,

- b : Contacting width of the packing (cm)
- \bar{p} : Average contacting pressure of the packing (Pa [kgf/cm²])
- R_{\max} : Maximum surface roughness of the rod (cm)

About compression force and extension force

The forces created by rod or piston packings that are fitted on the mounting groove and in contact with the contacting surface (the surface of the rod or the inner surface of the cylinder) is called compression force and extension force, respectively.

The sealing ability of packings for reciprocal movement depends on the maximum contacting pressure gradient of the pushing and pulling stroke. Therefore, the values of the compression and extension force are not enough to judge the sealing ability of a packing for reciprocal movement.



TYPES AND MAIN FEATURES OF NOK PACKINGS

Hydraulic seals for
reciprocal movement B-2-4

Dust seals for
reciprocal movement B-5

Buffer rings for
reciprocal movement B-6

Oil seals for
reciprocal movement B-6

Related products for
reciprocal movement B-7

Rotating oil seals for
high pressure B-8

Seals for oscillating and
rotating movement B-8









B. TYPES AND MAIN FEATURES OF NOK PACKINGS

- NOK provides various types of hydraulic seals, buffer rings, dust seals, and related products for reciprocating movement; rotating oil seals for high pressure; and seals for oscillating and rotating movement.
- Standard materials are offered for items in this catalog according to operating conditions.

(1) Hydraulic seals for reciprocal movement - 1

Type	NOK type	Cross section	Standard material	Main applicable fluid	Feature	Dimension table (page)		
	ODI		Noxlan (U801)	<ul style="list-style-type: none"> • General petroleum hydraulic fluid 	<ul style="list-style-type: none"> • Designed for large section, applicable for wide pressure range 	<ul style="list-style-type: none"> • Material, noxlan U801, has excellent wear resistance and sealing ability. 	F-3 ~ F-10	
	OSI		Noxlan (U801)				<ul style="list-style-type: none"> • Packings with a smaller section than ODI 	F-11 ~ F-13
	OUIS		Noxlan (U641)		<ul style="list-style-type: none"> • Designed for smaller section, and able to be fitted into integrated groove 	<ul style="list-style-type: none"> • Heat resistant material is employed, also has a good water resistance and durability. • Improvement has been made to prevent damages caused by back pressure. 		F-14 ~ F-15
	OUIHR		Nitrile rubber (A903)				<ul style="list-style-type: none"> • General petroleum hydraulic fluid • Petroleum hydraulic fluid for low temperature 	<ul style="list-style-type: none"> • Improvement against stick slip has been made. • The friction resistance is low and an improvement has been made to prevent damages caused by back pressure. • Nitrile rubber that has excellent low temperature resistance is employed and can be used with special low temperature hydraulic fluid oil (MIL H 5606E).
Special packing for piston seals	SPG		① Sliding material Rarefion, PTFE (19YF)	A980	<ul style="list-style-type: none"> • General petroleum hydraulic fluid oil • Water-glycol type hydraulic fluid oil • Oil-water emulsion type hydraulic fluid oil 	<ul style="list-style-type: none"> • This is a standard type of combination seal for wide range of application. 	F-19 ~ F-22	
			② Back ring material Nitrile rubber (A980) Fluoro rubber (F201)	F201			<ul style="list-style-type: none"> • General petroleum hydraulic fluid oil • Phosphate ester type hydraulic fluid oil 	—
	SPGW		① Sliding material Rarefion, PTFE (19YF)	A980	<ul style="list-style-type: none"> • General petroleum hydraulic fluid oil • Water-glycol type hydraulic fluid oil • Oil-water emulsion type hydraulic fluid oil 	<ul style="list-style-type: none"> • Rarefion (NOK product name of polytetrafluoroethylene resin) is used for sliding material. This packing has low frictional resistance, eliminating stick slip and assuring high wear resistance. 	<ul style="list-style-type: none"> • This is a seal for high pressure operation with improved ability of SPG for oil scraping off. • Backup ring material of polyamide resin assures high longevity. 	F-23 ~ F-26
			② Backup ring material Polyamide resin (80NP)	F201				<ul style="list-style-type: none"> • General petroleum hydraulic fluid oil • Phosphate ester type hydraulic fluid oil
	SPGO		① Sliding material Rarefion, PTFE (19YF)	A305	<ul style="list-style-type: none"> • General petroleum hydraulic fluid oil • Water-glycol type hydraulic fluid oil • Oil-water emulsion type hydraulic fluid oil 	<ul style="list-style-type: none"> • Installation space is saved because of bi-directional sealing ability by single packing. 	<ul style="list-style-type: none"> • This has the same performance as that of SPG. Installation space is saved because of JIS standard O ring. 	F-27 ~ F-30
			② Back ring material Nitrile rubber (A305) Fluoro rubber (F201)	F201				<ul style="list-style-type: none"> • General petroleum hydraulic fluid oil • Phosphate ester type hydraulic fluid oil
SPGC		① Sliding material Rarefion, PTFE (31BF)	A305	<ul style="list-style-type: none"> • General petroleum hydraulic fluid oil • Water-glycol type hydraulic fluid oil • Oil-water emulsion type hydraulic fluid oil 	<ul style="list-style-type: none"> • This packing can be fitted on to O ring groove (JIS B 2406 P series). • This has less sliding friction than O ring to assure high longevity. • This can also be used for pneumatic equipment. 	F-31 ~ F-34		
		② Back ring material Nitrile rubber (A305) Fluoro rubber (F201)	F201			<ul style="list-style-type: none"> • General petroleum hydraulic fluid oil 	—	



(1) Hydraulic seals for reciprocal movement - 2

Type	NOK type	Cross section	Standard material	Main applicable fluid	Feature	Dimension table (page)		
Special packing for piston seals	SPGI	 (Combination)	① Sliding material Noxlan (U641) ② Back ring material Nitrile rubber (A980)	• General petroleum hydraulic fluid oil	• Installation space is saved because of bi-directional sealing ability by single packing.	• Lip provided on the sliding surface improves the sealing ability. • This packing is suitable for the cylinders for controlling static position.	F-35 ~ F-36	
	CPI		Noxlan (U801)				• This packing is used for relatively low pressure operation.	• Packing material, noxlan has excellent wear resistance.
	CPH		Nitrile rubber (A102) (A103) (A104) (A505)	• General petroleum hydraulic fluid oil • Water-glycol type hydraulic fluid oil • Oil-water emulsion type hydraulic fluid oil	• Packing material, nitrile rubber, has excellent oil resistance and reduces sliding friction.	F-39 ~ F-40		
Special packing for rod seals	IDI		Noxlan (U801)	• General petroleum hydraulic fluid oil	• Packings with large section can be used for wide range of pressure.	• Packing material, noxlan U801 has excellent wear resistance and sealing ability.	F-41 ~ F-48	
	ISI		Noxlan (U801) (U641)				• Packings with a smaller section of IDI. • Material with heat resistance, U641 is also available.	F-49 ~ F-51
	IUH		Nitrile rubber (A505) (A903)	A505	• General petroleum hydraulic fluid oil • Water-glycol type hydraulic fluid oil • Oil-water emulsion type hydraulic fluid oil	• Packings with small section can be fitted in integrated groove.	• Improvement is made to prevent the damages caused by back pressure. • Material with excellent cold resistance, nitrile rubber A903 is also available. This can be used for special low temperature oil (MIL H 5606E).	F-52 ~ F-53
				A903	• General petroleum hydraulic fluid oil • Low temperature petroleum hydraulic fluid oil			
	UNI	 (Combination)	① Sliding material Noxlan (U801) ② Back ring material Silicon rubber (S813)	• General petroleum hydraulic fluid oil • Low temperature petroleum hydraulic fluid oil	• This packing is used for low temperature and high pressure operations.	• Noxlan is used for material and back ring can prevent the lack of interference at low temperature.	F-54 ~ F-56	
SPNO	 (Combination)	① Sliding material Rarefion, PTFE (19YF) ② Back ring material Nitrile rubber (A305) Fluoro rubber (F201)	A305	• General petroleum hydraulic fluid oil • Water-glycol type hydraulic fluid oil • Oil-water emulsion type hydraulic fluid oil	• Rarefion (NOK product name of polytetrafluoroethylene resin) is used for sliding material. This packing has low frictional resistance, eliminating stick slip and assuring high wear resistance.	• This is a standard type of combination seal and can be used for wide range of operation.	F-57 ~ F-59	
			F201	• General petroleum hydraulic fluid oil • Phosphate ester type hydraulic fluid oil				
SPN	 (Combination)	① Sliding material Rarefion, PTFE (19YF) ② Back ring material Nitrile rubber (A980) Fluoro rubber (F201)	A980	• General petroleum hydraulic fluid oil • Water-glycol type hydraulic fluid oil • Oil-water emulsion type hydraulic fluid oil	• This has the same performance as SPNO. This is used in case the service range of pressure is wide and sliding speed is high.	F-60 ~ F-62		
			F201	• General petroleum hydraulic fluid oil • Phosphate ester type hydraulic fluid oil				









Remark 1) Items with a "~" mark in the dimension table column have unique specifications. Please consult NOK before ordering since there is no dimension description.

Remark 2) Some of the packing profiles, especially small sizes, may not be fitted in the integrated groove.

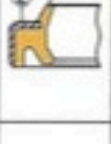
(1) Hydraulic seals for reciprocal movement - 3

Type	NOK type	Cross section	Standard material	Main applicable fluid	Feature	Dimension table page			
Special packing for rod seals	SPNC	 (Combination)	① Sliding material Reneflon, PTFE (31BF)	A305	<ul style="list-style-type: none"> General petroleum hydraulic fluid oil Water-glycol type hydraulic fluid oil Oil-water emulsion type hydraulic fluid oil 	<ul style="list-style-type: none"> Reneflon (NOK product name of polytetrafluoroethylene resin) is used for sliding material. This packing has low friction resistance eliminating stick slip and assuring high wear resistance. Installation space is saved because of bi-directional sealing ability by single packing. 	F-63 ~ F-66		
			② Back ring material Nitrile rubber (A305) Fluoro rubber (F201)				F201	<ul style="list-style-type: none"> General petroleum hydraulic fluid oil Phosphate ester type hydraulic fluid oil 	—
Packing for both piston and rod seals	UPI		Noxlan (U801)	<ul style="list-style-type: none"> General petroleum hydraulic fluid oil 	<ul style="list-style-type: none"> This can be used both for piston and rod seals. This packing has large section and can be used for wide range of operations. 	<ul style="list-style-type: none"> Material, noxlan U801, has excellent wear resistance and sealing ability. 	F-67 ~ F-72		
	USI		Noxlan (U593)				<ul style="list-style-type: none"> This can be used both for piston and rod seals. This packing has small section and can be fitted in integrated groove. 	<ul style="list-style-type: none"> This is a type with smaller section of UPI. Improvement has been made to prevent damages caused by back pressure. 	F-73 ~ F-76
	UPH		Nitrile rubber (A505) Fluoro rubber (F357)	A505	<ul style="list-style-type: none"> General petroleum hydraulic fluid oil Water-glycol type hydraulic fluid oil Oil-water emulsion type hydraulic fluid oil 	<ul style="list-style-type: none"> This can be used both for piston and rod seals. This packing has large section and can be used for wide range of operations. 	<ul style="list-style-type: none"> Nitrile rubber and fluoro rubber are available for material to assure wide range of operating temperature. Wide variation of size is available. 	F-77 ~ F-84	
				F357				<ul style="list-style-type: none"> General petroleum hydraulic fluid oil Phosphate ester type hydraulic fluid oil 	
	USH		Nitrile rubber (A505) (A903) Fluoro rubber (F357)	A505	<ul style="list-style-type: none"> General petroleum hydraulic fluid oil Water-glycol type hydraulic fluid oil Oil-water emulsion type hydraulic fluid oil 	<ul style="list-style-type: none"> This can be used both for piston and rod seals. This packing has small section and can be fitted in integrated groove. 	<ul style="list-style-type: none"> This is a type with a smaller section of UPH. 	F-85 ~ F-88	
				A903				<ul style="list-style-type: none"> General petroleum hydraulic fluid oil Low temperature petroleum hydraulic fluid oil 	—
				F357				<ul style="list-style-type: none"> General petroleum hydraulic fluid oil Phosphate ester type hydraulic fluid oil 	F-85 ~ F-88
	USHR		Nitrile rubber (A505)	<ul style="list-style-type: none"> General petroleum hydraulic fluid oil Water-glycol type hydraulic fluid oil Oil-water emulsion type hydraulic fluid oil 	<ul style="list-style-type: none"> This is interchangeable with USH, suitable for operation handling less lubricity fluid, and also effective to prevent stick slip. 	—			
	V99F		Fabric reinforced nitrile rubber (21AG) Fabric reinforced fluoro rubber (34BG)	21AG	<ul style="list-style-type: none"> General petroleum hydraulic fluid oil Water-glycol type hydraulic fluid oil Oil-water emulsion type hydraulic fluid oil water 	<ul style="list-style-type: none"> This can be used for severe operating conditions by plying packings according to the operation pressure. Installation width is larger than U packings. Less sealing ability than U packings. 	<ul style="list-style-type: none"> This is a standard type of V packing. 	F-89 ~ F-94	
				34BG				<ul style="list-style-type: none"> General petroleum hydraulic fluid oil Phosphate ester type hydraulic fluid oil Agricultural chemicals 	—
V96H		Nitrile rubber (A505) Fluoro rubber (F357)	A505	<ul style="list-style-type: none"> General petroleum hydraulic fluid oil Water-glycol type hydraulic fluid oil Oil-water emulsion type hydraulic fluid oil water 	<ul style="list-style-type: none"> Compared with V99F, this is selected in case the sealing performance is more important. We recommend to use this in combination with V99F. 	F-95 ~ F-100			
			F357			<ul style="list-style-type: none"> General petroleum hydraulic fluid oil Phosphate ester type hydraulic fluid oil Agricultural chemicals 	—		

(2) Dust seals for reciprocal movement



Type	NOK type	Cross section	Standard material	Main applicable fluid	Feature	Dimension table (page)	
Dust seals	DKI	 (Combination)	① Lip material Noxlan (U801) ② Metal case material, Cold rolled steel plate sheet (SPCC)		• This is a standard type of dust seal of noxlan with high dust proof performance.	F-101 ~ F-103	
	DWI		① Lip material Noxlan (U801) ② Metal case material, Cold rolled steel plate sheet (SPCC)		• Employing noxlan as material, this seal serves under severe dust conditions such as construction equipment.	F-104 ~ F-105	
	DWIR		① Lip material Noxlan (U801) ② Metal case material, Cold rolled steel plate sheet (SPCC)		• Employing noxlan as material, this has the same performance as DWI, excellent in preventing of oil scraping off and in follow-ability to the eccentricity.	F-106 ~ F-107	
	DKBI		① Lip material Noxlan (U801) ② Metal case material, Cold rolled steel plate sheet (SPCC)		• This is a seal to prevent entry of dust and protect equipment and maintain sealing performance of packings. • Employing noxlan as material, this is a double-lip dust seal to prevent oil scraping off.	F-108 ~ F-109	
	DKB		① Lip material Nitrile rubber (A795) (A980) Fluoro rubber (F384) ② Metal case material, Cold rolled steel plate sheet (SPCC)	A795	• Outside dust	• Employing nitrile rubber as material, this is a double-lip dust seal to prevent oil scraping off.	F-110 ~ F-112
				A980			—
				F384			—
	DKH		① Lip material Nitrile rubber (A104) (A795) (A980) Fluoro rubber (F384) ② Metal case material, Cold rolled steel plate sheet (SPCC)	A104 A795	• Employing nitrile rubber as material, this is a single-lip dust seal. • Material A795: for diameter ϕ 300 or less A104: for diameter over ϕ 300	F-113 ~ F-115	
				A980		—	
				F384		—	
DSI		Noxlan (U801)		• This is a seal to prevent entry of dust and protect equipment and maintain sealing performance of packings.	F-116 ~ F-118		
LBI		Noxlan (U593)		• This is a seal to prevent entry of dust and protect equipment and maintain sealing performance of packings. • This can be fitted into a integrated groove.	F-119 ~ F-120		
LBH		Nitrile rubber (A505) (A903) Fluoro rubber (F357)	A505	• This is a seal to prevent entry of dust and protect equipment and maintain sealing performance of packings. • This can be fitted into a integrated groove.	• Employing noxlan as material, this is a double-lip all rubber dust seal to prevent oil scraping off. • This is a double-lip all rubber dust seal to prevent oil scraping off. • Nitrile rubber and fluoro rubber are available as material for wide range of operating temperature.	F-121 ~ F-124	
			A903			—	
			F357			F-121 ~ F-124	

Remark 1) Items with a "*" mark in the dimension table column have unique specifications.





Please consult NOK before ordering since there is no dimension description.

Remark 2) Some of the packing profiles, especially small sizes, may not be fitted in the integrated groove.







(3) Buffer rings for reciprocal movement

Type	NOK type	Cross section	Standard material	Main applicable fluid	Feature	Dimension table (page)
Buffer ring	HBV	 (Combination)	① Packing material Noxlan (U801) ② Backup ring material Polyamide resin (80NP)	• General petroleum hydraulic fluid oil	<ul style="list-style-type: none"> This is used in combination with rod packing to absorb the impact and fluctuating pressure at high load, to isolate high temperature fluid, and to improve the durability of the packing. Special shaped slit at the sliding lip that can leak back pressure eliminates the pressure between the rod packing and buffer ring. 	F-125 ~ F-126
	HBTS	 (Combination)	① Sliding material Rarefion (19BF) ② Back ring material Nitrile rubber (A626) Fluoro rubber (F201)	A626 <ul style="list-style-type: none"> General petroleum hydraulic fluid oil Water-glycol type hydraulic fluid oil Oil-water emulsion type hydraulic fluid oil F201 <ul style="list-style-type: none"> General petroleum hydraulic fluid oil Phosphate ester type hydraulic fluid oil 		<ul style="list-style-type: none"> This has the same function as that of HBV. This has small friction resistance and suits for high speed, extremely short stroke operation. A slit on the tapered surface (non-sliding surface) can leak back pressure.

(4) Oil seals for reciprocal movement



Type	NOK type	Cross section	Standard material	Main applicable fluid	Feature	Dimension table (page)
Oil seals for reciprocal movement	TB4		① Lip material Nitrile rubber (A795) ② Metal case material Cold rolled steel plate sheet (SPCC)	<ul style="list-style-type: none"> General petroleum hydraulic fluid oil Water-glycol type hydraulic fluid oil Oil-water emulsion type hydraulic fluid oil 	<ul style="list-style-type: none"> This is a seal for low friction used under the condition of low pressure and high speed. This can also be used as dust seal for hydraulic cylinder. Rubber and metal are available for seal O.D. which will be selected according to the housing material. 	Refer to oil seal catalogue.
	TC4		③ Spring material Piano wires (SWP)			
Seals for operation valve	SVY		① Lip material Nitrile rubber (A216) ② Metal case material Cold rolled steel plate sheet (SPCC) ③ Spring material Piano wires (SWP)	• General petroleum hydraulic fluid oil	<ul style="list-style-type: none"> This is a special seal mainly used for valve unit of industrial equipment. This has an excellent sealing ability and low friction. 	—
Power steering seals	SCJY	 (Combination)	① Lip material Nitrile rubber (A297) ② Metal case material Cold rolled steel plate sheet (SPCC) ③ Spring material Stainless steel (SUS) ④ Backup ring Polyamide resin (80NP)	• General power steering fluid oil	<ul style="list-style-type: none"> This is a special seal mainly used for automobile power steering. Backup ring of resin material is used to minimize lip deformation under high pressure. Stainless steel is used for spring to maintain required interference and compression force of lip for long duration and high speed operation. 	—

(5) Relating products for reciprocal movement



Type	NOK type	Cross section	Standard material	Main applicable fluid	Feature	Dimension table (page)	
Wear rings	RYT		Rarefion, PTFE (05ZF)	<ul style="list-style-type: none"> General petroleum hydraulic fluid oil Water-glycol type hydraulic fluid oil Oil-water emulsion type hydraulic fluid oil Phosphate ester type hydraulic fluid oil Low temperature petroleum hydraulic fluid oil 	<ul style="list-style-type: none"> This is used as bearing of piston to prevent its scoring or eccentricity and to improve the durability of the packings. 	<ul style="list-style-type: none"> Supplied in hoop (10m/roll) enabling to be cut according to the cylinder diameter. Rarefion (NOK product name of polytetrafluoroethylene resin) is used for material. This wear ring has low frictional resistance eliminating stick slip. 	F-129 ~ F-130
	WR		Fabric reinforced phenolic resin (12RS)				
Containment seals	KZT		Rarefion, PTFE (05ZF)		<ul style="list-style-type: none"> This is used in combination with piston packings and wear rings to prevent damages of packings caused by foreign object in oil within the cylinder and to assure long life of packings. When used in combination with rod packing and metal bush, damages of the rod can be prevented because of the foreign object submerging function of rarefion (NOK product name of polytetrafluoroethylene resin). One point cut is provided and oil pressure bypass slot is also provided to prevent pressure accumulation. 	F-135 ~ F-137	
Backup ring	BRT2		Rarefion, PTFE (19YF)		<ul style="list-style-type: none"> This is used to prevent extrusion of packings and to improve the pressure resistance of the packings. 	<ul style="list-style-type: none"> Standard cutting shape is bias-cut (BRT2). If there are no problem for installation, no cut endless type (BRT3) can be also used. 	F-138 ~ F-141
	BRT3		Rarefion (31BF)	<ul style="list-style-type: none"> Standard cutting shape is bias-cut (BRN2). If there are no problem for installation, no cut endless type (BRN3) can be also used. 			
	BRN2		Polyamide resin (80NP) (12NM)	<ul style="list-style-type: none"> Standard cutting shape is bias-cut (BRN2). If there are no problem for installation, no cut endless type (BRN3) can be also used. 			
	BRN3						

Remark: Items with a "*" mark in the dimension table column have unique specifications. Please consult NOK before ordering since there is no dimension description.

(6) Rotating oil seals for high pressure

Type	NOK type	Cross section	Standard material	Main applicable fluid	Feature	Dimension table (page)	
Oil seals for rotating pressure	TCV		① Lip material Nitrile rubber (A795) Fluoro rubber (F584)	A795	• General petroleum hydraulic fluid oil	<ul style="list-style-type: none"> This is used for relatively small diameter and medium pressure operation. This is a standard type of oil seals for rotating pressure. This is used for relatively large diameter and high pressure operation. 	Refer to oil seal catalogue.
			② Metal case material Cold rolled steel plate sheet (SPCC)	F548	• General petroleum hydraulic fluid oil • Phosphate ester type hydraulic fluid oil		
	TCN	 (Combination)	① Lip material Nitrile rubber (A795) Fluoro rubber (F584)	A795	• General petroleum hydraulic fluid oil		
			② Metal case material Cold rolled steel plate sheet (SPCC) ③ Spring material Piano wires (SWP)	F548	• General petroleum hydraulic fluid oil • Phosphate ester type hydraulic fluid oil		

(7) Seals for oscillating and rotating movement

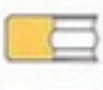
Type	NOK type	Cross section	Standard material	Main applicable fluid	Feature	Dimension table (page)	
Hinge pin dust seals	DLI 2		① Lip material Noxlan (U451) ② Metal case material Cold rolled steel plate sheet (SPCC)	• Outer dust	<ul style="list-style-type: none"> This is a dust seal for oscillating and rotating movement for hinge pin and bush. This can be used under severe dust conditions to improve the durability of the equipment. Relief effect makes easy to drain used grease when filling up new grease. 	<ul style="list-style-type: none"> This can be applied to the housing diameter ϕ 160 or less. 	F-142 ~F-143
	DLI		① Lip material Noxlan (U593) ② Metal case material Cold rolled steel plate sheet (SPCC)		<ul style="list-style-type: none"> This is mainly used to the housing diameter exceeding ϕ 160. 	F-144 ~F-145	
	VAY	 (Combination)	① Lip material Nitrile rubber (A104) ② Metal case material Cold rolled steel plate sheet (SPCC)		<ul style="list-style-type: none"> Lip shape is specially designed to reduce the torque. Lip wear is reduced because of metallic protection plate. 	—	
Center seal seals	ROI		Noxlan (U801) (U652)	• General petroleum hydraulic fluid oil	<ul style="list-style-type: none"> This is a special seal for center swivel with excellent wear resistance and extrusion proof ability. Since perfect sealing cannot be expected, please provide a drain at end and use oil seals for rotating pressure with it. 	—	

Remark: Items with a "*" mark in the dimension table column have unique specifications. Please consult NOK before ordering since there is no dimension description.



COMPOSITION OF NOK PACKINGS

Types and characteristics of
rubber material _____ C-2-3

Types and characteristics of
resin material _____ C-4-5



COMPOSITION OF NOK PACKINGS

NOK supplies several different types of packing materials to suit various applications. Table C-1 shows the type and characteristics of rubber materials and Table C-2 shows the type and characteristics of resin material. Standard materials are offered for items in this catalog to best meet the operating conditions. Refer to chapter B for the types and features of each type of packing. Compatibility in the following tables indicates general tendencies. Refer to the resistivity data in chapter J for resistivity to specific brands of oil.

Table C-1 Types and characteristics of NOK rubber material

Material	NOK material code	Material							Resistivity													
		Hardness (JIS A)	Tensile strength (MPa) (kgf/cm ²)	100% modulus (MPa) (kgf/cm ²)	Elongation (%)	Permanent compression set (%) Test condition A: 80°C 70h B: 100°C 70h C: 175°C 70h	Hardness change by air oven aging test (point)	Low temperature brittleness TR ₁₀ (°C)	Lubricating oil (agent)													
									Engine oil	Gear oil	Machine oil	Spindle oil	Refrigerator oil	Cup grease	Lithium grease	Silicon grease	Turbine oil	Oil + water emulsion type				
Nitrile rubber	A102	60	17.1 [174]	2.6 [27]	470	32 (B)	+7 (B)	-22	○	○	○	○	○	○	○	○	○	○	○	○	○	
	A103	70	19.3 [197]	4.5 [46]	430	33 (B)	+5 (B)	-22	○	○	○	○	○	○	○	○	○	○	○	○	○	
	A104	80	19.0 [194]	7.3 [74]	340	31 (B)	+5 (B)	-21	○	○	○	○	○	○	○	○	○	○	○	○	○	
	A216	85	19.2 [196]	11.2 [114]	190	26 (B)	+5 (B)	-36	○	○	○	○	○	○	○	○	○	○	○	○	○	
	A297	75	21.5 [219]	4.8 [49]	260	18 (B)	+5 (B)	-34	○	○	○	○	○	○	○	○	○	○	○	○	○	
	A305	70	20.5 [209]	4.3 [44]	340	10 (B)	+2 (B)	-23	○	○	○	○	○	○	○	○	○	○	○	○	○	○
	A402	60	12.8 [130]	2.3 [24]	440	13 (B)	+3 (B)	-26	○	○	○	○	○	○	○	○	○	○	○	○	○	○
	A505	90	20.5 [209]	15.4 [157]	170	31 (B)	+2 (B)	-22	○	○	○	○	○	○	○	○	○	○	○	○	○	○
	A626	70	17.6 [180]	5.0 [51]	260	13 (B)	+7 (B)	-35	○	○	○	○	○	○	○	○	○	○	○	○	○	○
	A795	80	20.4 [208]	7.8 [80]	400	48 (B)	+6 (B)	-11	○	○	○	○	○	○	○	○	○	○	○	○	○	○
	A903	85	14.4 [147]	13.5 [138]	110	20 (B)	+4 (B)	-51	○	○	○	○	○	○	○	○	○	○	○	○	○	○
A980	80	13.6 [139]	10.5 [107]	150	17 (B)	+3 (B)	-52	○	○	○	○	○	○	○	○	○	○	○	○	○	○	
Fluoro rubber	F201	70	14.2 [145]	5.0 [51]	230	7 (C)	0 (C)	-15	○	△	○	○	○	○	○	○	○	○	○	○	△	
	F268	90	18.5 [189]	15.5 [158]	150	20 (C)	+1 (C)	+4	○	○	○	○	○	○	○	○	○	○	○	○	○	
	F357	90	17.4 [178]	12.3 [126]	140	18 (C)	+1 (C)	-15	○	△	○	○	○	○	○	○	○	○	○	○	△	
	F384	80	11.6 [118]	10.8 [110]	200	70 (C)	+1 (C)	-12	○	△	○	○	○	○	○	○	○	○	○	○	○	
	F548	85	10.6 [108]	7.7 [79]	230	22 (C)	+1 (C)	-16	○	△	○	○	○	○	○	○	○	○	○	○	△	
Silicon rubber	S813	70	7.2 [73]	5.4 [55]	150	16 (C)	+1 (C)	-49	○	△	○	△	△	△	△	△	△	△	△	△	△	
Noxlan (Polyurethane rubber)	U451	93	40.8 [416]	10.5 [107]	580	28 (A)	0 (B)	-30	○	△	○	○	○	○	○	○	○	○	○	○	○	
	U593	92	27.3 [279]	12.5 [128]	280	25 (A)	0 (B)	-34	○	△	○	○	○	○	○	○	○	○	○	○	○	
	U641	94	43.2 [441]	11.5 [117]	420	30 (A)	0 (B)	-18	○	△	○	○	○	○	○	○	○	○	○	○	△	
	U652	96	43.2 [441]	12.5 [128]	440	30 (A)	0 (B)	-17	○	△	○	○	○	○	○	○	○	○	○	○	△	
	U695	96	44.2 [451]	14.7 [150]	450	35 (A)	0 (B)	-18	○	△	○	○	○	○	○	○	○	○	○	○	△	
	U801	94	43.2 [441]	12.5 [128]	480	30 (A)	0 (B)	-29	○	△	○	○	○	○	○	○	○	○	○	○	○	
Fabric reinforced rubber	21AG	—	—	—	—	—	—	—	○	○	○	○	○	○	○	○	○	○	○	○	○	
	34BG	—	—	—	—	—	—	—	○	○	○	○	○	○	○	○	○	○	○	○	○	
Hydrogenated nitrile rubber	G506	90	26.9 [274]	16.5 [168]	170	12 (B)	+1 (B)	-24	○	○	○	○	○	○	○	○	○	○	○	○	○	

Resistivity standards ○ : Very good × : Not recommended
 ○ : Good for most applications[®]
 — : No resistivity data available or the resistivity varies depending on the ingredient. Please consult NOK.
 △ : Fair, can be used if no other materials exist, otherwise not recommended[®]
[®] Please consult NOK before using these materials.

Resistivity													Features	Applicable NOK packing types			
Hydraulic fluid oil						Water and others					Heat resistance	Cold temperature resistance			Wear resistance		
Water + glycol type	Water + hydraulic oil	Water + hydraulic oil	Phosphate ester type	Silicon oil	Brake fluid	Torque converter oil	Water	Steam and hot water	Water soluble cutting oil	Chloric cutting oil							
○	○	○	×	○	△	○	△	△	○	×	○	○	○	○	○	Standard material of L shaped packings	CPH
○	○	○	×	○	△	○	△	△	○	×	○	○	○	○	○	Standard material of valve unit seals	SVY
○	○	○	×	○	△	△	△	△	○	×	△	×	○	○	○	Standard material of power steering seals	SCJY
○	○	○	×	○	△	△	○	△	×	△	×	○	○	○	○	Standard material of O ring (JIS B 2401 1 type A)	SPGC·SPNC·SPNO·SPGO
○	○	○	×	○	△	△	○	△	×	△	×	○	○	○	○	Standard material of back ring for large diameter combination seals	SPG
○	○	○	×	○	△	△	○	△	×	△	×	○	○	○	○	Standard material of nitrile rubber packings	IUH·UPH·USHR·LBH·V96H·USH·CPH
○	○	○	×	○	△	△	△	△	×	△	×	○	○	○	○	Standard material of back ring (O ring) for buffer rings	HBTS
○	○	△	×	○	△	△	△	△	×	△	×	△	○	△	○	Standard material of dust seals for reciprocal movement and oil seal for pressure resistance	TB4·TC4·TCV·TCN·DKB·DKH
○	○	△	×	○	△	△	△	△	×	△	×	△	○	△	○	Material for cold resistance packings (Improved material of 1195 for better oil resistance)	OUHR·IUH·USH·LBH
○	○	△	×	○	△	△	○	△	○	×	△	○	○	○	○	Standard material of back ring for combined seals	SPG·SPGW·SPN·DKB·SPGI
△	○	○	○	○	△	△	△	△	△	○	○	△	○	△	○	Heat resistance material of back ring for combined seals	HBTS·SPG·SPGW·SPGC·SPNC·SPNO·SPN
○	○	△	○	○	△	△	○	△	○	○	○	○	○	×	○	Material for heat, water, and steam resistance packings	UPH·USH
△	○	○	○	○	△	△	△	△	△	○	○	△	○	△	○	Standard material for heat resistance packings	UPH·USH·LBH·V96H
○	○	○	○	○	△	△	△	△	△	○	○	△	○	△	○	Heat resistance material of dust seals for reciprocal movement	DKB·DKH
△	○	○	○	○	△	△	△	△	△	○	○	△	○	△	○	Heat resistance material of oil seals for pressure resistance	TCV·TCN
○	—	—	○	×	○	○	○	△	△	—	—	○	○	△	△	Material of back ring for U packings	UNI
×	×	○	×	○	×	○	△	×	×	—	—	○	○	○	○	Material of hinge pin dust seals	DLI2
×	×	○	×	○	×	○	△	×	×	—	—	○	○	○	○	Noxlan improved for better cold resistance	USI·LBI·DLI
△	△	○	×	○	×	○	○	△	△	—	—	○	△	○	△	Noxlan improved for better heat and water resistance	SPGI·ISI·OUIS
△	△	○	×	○	×	○	○	△	△	—	—	○	△	○	△	Material for center swivel seals	ROI
△	△	○	×	○	×	○	○	△	△	—	—	○	△	○	△	Noxlan improved for better grease and water resistance	(for bushes mainly dust seals)
×	×	○	×	○	×	○	△	×	×	—	—	○	○	○	○	Standard material of noxlan packings	ODI·OSI·CPI·DI·ISI·UNI·UPI·DKI·DKBI·DWI·ROI·DSI·HSY·DWR
○	○	○	×	○	△	△	△	△	○	×	○	○	△	○	○	Standard material of fabric reinforced V packings (nitrile rubber)	V99F
○	○	○	○	○	△	△	△	△	△	○	○	○	△	○	○	Heat resistance material of fabric reinforced V packings (fluororubber)	
○	○	○	×	○	△	△	○	×	△	×	○	○	○	○	○	Special nitrile rubber for better heat and wear resistance	(for packings and dust seals)

Table C-2 Types and characteristics of NOK resin material

Material	NOK material code	Material					Resistivity											
		Hardness	Tensile strength (MPa) (kgf/cm ²)	Elongation (%)	Compression strength (MPa) (kgf/cm ²)		Applicable temperature range (°C)	Lubricating oil (agent)										
					2.5% deformation	10% deformation		Engine oil	Gear oil	Machine oil	Spindle oil	Refrigerator oil	Cup grease	Lithium grease	Silicon grease	Turbine oil	Oil-water emulsion type	
Rarefion (polytetrafluoroethylene, PTFE, resin)	19YF (Duromer D)	70	19.6 (200)	120	12.8 (131)	23.1 (236)	-55 ~ 220	○	○	○	○	○	○	○	○	○	○	○
	49YF (Duromer D)	70	17.7 (181)	140	16.0 (163)	25.0 (255)		○	○	○	○	○	○	○	○	○	○	○
	31BF (Duromer D)	65	18.6 (190)	330	11.8 (120)	20.1 (205)		○	○	○	○	○	○	○	○	○	○	○
	05ZF (Duromer D)	62	19.6 (200)	220	12.1 (123)	19.6 (200)		○	○	○	○	○	○	○	○	○	○	○
Polyamide resin	60NP (Rockwell R)	109	52.0 (531)	300	19.6 (200)	49.1 (501)	-55 ~ 100	○	○	○	○	○	○	○	○	○	○	○
	80NP (Rockwell R)	120	78.5 (801)	15	39.2 (400)	72.6 (741)	-55 ~ 120	○	○	○	○	○	○	○	○	○	○	○
	12NM (Rockwell R)	123	102.0 (1040)	8	38.0 (388)	100.0 (1020)	-55 ~ 140	○	○	○	○	○	○	○	○	○	○	○
Fabric reinforced phenolic resin	12RS (Rockwell M)	105	137.4 (1402) * Flex strength	—	242 (2470) * Destruction	—	-55 ~ 120	○	○	○	○	○	○	○	○	○	○	○

Resistivity standards ○ : Very good
 ○ : Good for most applications*
 △ : Fair, can be used if no other materials but otherwise not recommended*
 ※ : Please consult NOK before using these materials.

Low temperature retraction of rubber material

TR₁₀ value is used to judge low temperature capability of material. TR is an abbreviation for "Temperature-Retraction" as described by ASTM D 1329 and expresses the distortion recovery ability in low temperature. This is roughly the same as recovery of rubber-like elastomer. TR₁₀ value is the temperature where initial distortion has recovered by 10%. Graph C-1 shows an example of measuring this value.

Graph C-1 TR graph

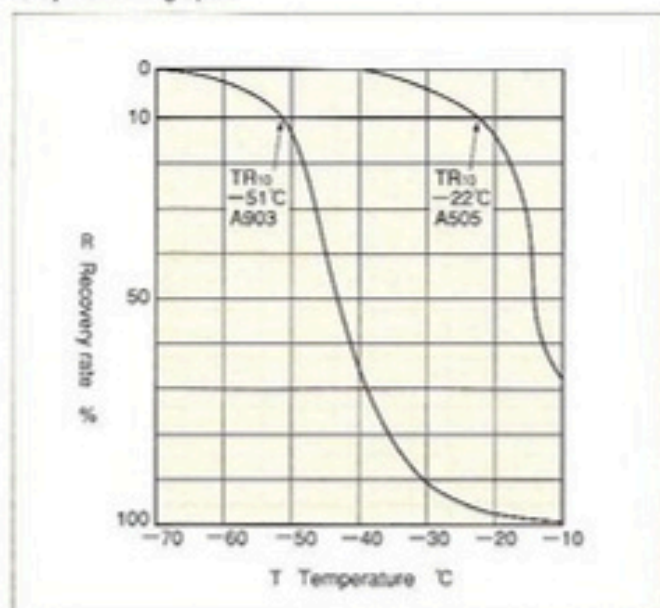

TR₁₀ values can indicate allowable low temperature service range of rubber material for packings. For allowable low temperature service range of specific types of packings, refer to page D-2 to 4.

Resistivity													Features	Recommended NOK types		
Hydraulic fluid oil						Water and others						Heat resistance			Cold-temperature resistance	Wear resistance
Water + glycol type	Water soluble hydraulic fluid	Water emulsion hydraulic fluid	Phosphate ester type	Silicon oil	Brake fluid	Torque converter oil	Water	Steam and hot water	Water soluble cutting oil	Chloric cutting oil	Sulfur cutting oil					
○	○	○	○	○	○	○	○	○	○	○	○	○	○	○	Rarefion material with high extrusion and wear resistance	BRT2,3-SPG-SPGW-SPGO-SPN-SPNO-HBTS
○	○	○	○	○	○	○	○	○	○	○	○	○	○	○	Special material improving extrusion resistance of 19YF	(Combined seals, backup ring)
○	○	○	○	○	○	○	○	○	○	○	○	○	○	○	Rarefion material with better wear and creep resistance than with pure PTFE	BRT2,3-SPGC-SPNC
○	○	○	○	○	○	○	○	○	○	○	○	○	○	○	Bearing material containing bronze for high speed and light load	KZT-RYT
○	○	○	○	○	○	○	△	△	△	○	○	○	○	○	Material of backup ring for special seals	SCJY
○	○	○	○	○	○	○	△	△	△	○	○	○	○	○	Material of high pressure backup ring with high-wear resistance and mechanical strength. Its cutting manufacturing process makes large diameter seals available.	BRN2,3-SPGW-HBY
○	○	○	○	○	○	○	△	△	△	○	○	○	○	○	Material for injection molding having the same performance as BONP with smaller dimension changes by water absorption	(Backup ring)
○	○	○	○	○	○	○	○	○	○	○	○	○	○	○	Material for bearing with excellent wear resistance and mechanical strength	WR

Hardness of the material

Hardness of the material indicates pressure resistance and strength of a seal, including tensile strength. For example, the pressure resistance of rubber for a packing (extrusion resistance) is indicated by the hardness of the rubber (refer to Fig. D-6 on page D-6). The testing method for material hardness is expressed by the industrial standard for each material as shown in Table C-3.

Table C-3 details a new testing method for vulcanized rubber hardness, JIS K 6253, besides JIS K 6301 (physical testing method for vulcanized rubber).

In this catalog, rubber hardness is expressed by spring-type hardness (JIS A) of JIS K 6301. Figure C-2 shows the correlation of each material hardness.

Table C-3 Testing method of material hardness

Vulcanized rubber	Rarefion (polytetrafluoroethylene resin)	Polyamide resin (thermoplastics resin)	Phenolic resin (thermosetting resin)
JIS K 6301 JIS K 6253	JIS K 7215	JIS K 7202	JIS K 6911

Figure C-2 Correlation of each material hardness

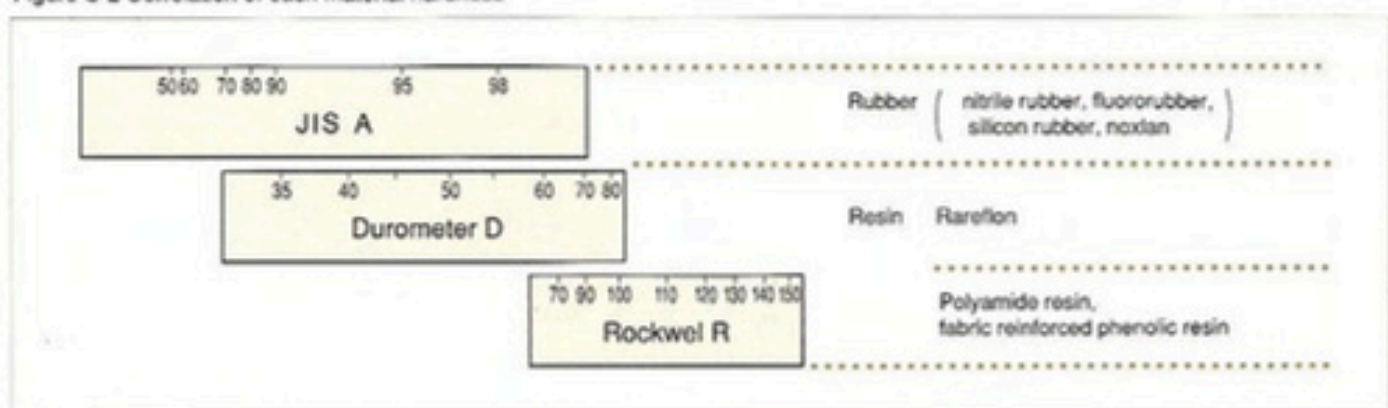

C



SELECTING NOK PACKINGS

Application Range

1. Application Range of Hydraulic Seals for Reciprocating Application D 2-3
2. Application Range of Dust Seals D 2-4
3. Application Range of Related Products for Hydraulic Equipment D-4
4. Application Range of Backup Rings D 5-6
5. Application Range of Wear Rings D 7-9

Packing Selection

1. Correlation of Packing Types D 10-11
2. Selecting Dust Seals D-12

The packings in this catalogue are neither designed nor manufactured to the use for medical application. Please do not use the products in this catalogue for the application physically contacting body fluid or biosystem, or as a transplant material to human body.

D.SELECTING NOK PACKINGS

Application Range

Selecting material and the type most suitable for the operating condition is necessary to obtain optimal performance of the packing. In this chapter, we will describe the application range of seals and related products for hydraulic equipment, plus means of selection. Tables D-1, D-2, D-3, and D-4 show the application range of hydraulic seals for reciprocating motion, dust

1. Application Range of Hydraulic Seals for Reciprocating Application

Select NOK packing taking the following four conditions into consideration: 1. Pressure 2. Temperature 3. Speed 4. Stroke

<Table D-1> Application Range of Hydraulic Seals for Reciprocating Motion

Kind Classification Item Type	Special packings for piston seals										
	U				S					L	
Type	ODI	OSI	OUIS	OUHR	SPG	SPGW	SPGO	SPGC	SPGI	CPI	CPH
Shape											
Pressure (MPa) ^{max}	35 *30	42 *30	42 *30	21 *14	35	50	35		21	7	3.5
Temperature (°C) ^{max}	100 -25	100 -20	110 -10	80 -25	100 -40	120 -20	100 -20	100 -20	80 -40	100 -25	100 -25
Speed (m/s)	0.5	0.5	0.5	1.0	1.5	1.5	1.5	1.5	1.0	0.3	0.3
Stroke (mm)	2,000 or less										
Fitting space	Medium	Small	Small	Small	Small	Small	Small	Very small	Small	Medium	Medium
Sliding resistance	Medium	Medium	Small	Small	Very small	Very small	Very small	Very small	Small	Small	Small
Installer with integral groove	No	Yes	Yes	Yes	Yes	Yes	Yes	Yes	Yes	No	No
Dimension table (page)	F-3	F-11	F-14	F-16	F-19	F-23	F-27	F-31	F-35	F-37	F-39

2. Application Range of Dust Seals

(1) Dust seals for reciprocating application

The main feature of a dust seal is to seal outside dust. In addition, a sealing system using a dust seal, combined with rod packings and a buffer ring, can prevent oil film being scraped out. Since these two features (dust elimination and oil scraping) conflict with each other, it is important to clarify the priority required for each application before selecting the dust seals. Specific performance will vary depending upon the type of dust seal. Therefore, if maintaining oil film on a cylinder is more important, please consult NOK.

<Table D-2> Application range of dust seals for reciprocating motion

Classification Item Type	Dust seals		
	DKI	DWI	DWIR
Shape			
Temperature (°C) ^{max}	100 -25	100 -25	100 -25
Dust proof performance	○	○	○
Oil scraping performance	Medium	Small	Very small
Requirement of stopper	No	No	No
Installer with integral groove	No	No	No
Dimension table (page)	F-101	F-104	F-106

seals for reciprocating motion, dust seals for oscillating motion, and related products for hydraulic equipment. In the following case, the combined effect of operating conditions must be carefully considered, therefore, please consult NOK.

- (1) In case of minimum pressure exceeding 3MPa at all times
- (2) In case of using packing at the border range of applicable temperature and pressure
- (3) In case of using packing with extremely short strokes (See examples of using with extremely short strokes on page I-10 and 11.)
- (4) In case of using packing when speed of extending stroke of rod is greater than that of contracting stroke

Special packings for rod seals							Packings for both piston and rod seals					
U				S			U				V	
IDI	ISI	IUH	UNI	SPNO	SPN	SPNC	UPI	USI	UPH	USH	V99F	V96H
70 *30	42 *30	21 *14	42 *30	35	35	7	35	21	32 *15	21 *14	30 (3.5) 14 (4.5) (3.5)	30 (3.5) 8 (4.5) (3.5)
1.0	1.0	1.0	1.0	1.5	1.5	1.4	1.0 For rod 0.5 For piston	1.0	1.0	1.0	1.0	0.5
2,000 or less							2,000 or less					
Medium	Small	Small	Medium	Small	Medium	Very small	Medium	Small	Medium	Small	Large	Large
Medium	Medium	Small	Medium	Very small	Very small	Very small	Medium	Small	Medium	Small	Large	Large
No	Yes	Yes	No	Yes	Yes	No	No	Yes	No	Yes	No	No
F-41	F-49	F-52	F-54	F-57	F-60	F-63	F-67	F-73	F-77	F-85	F-89	F-95

Dust seals					
DKBI	DKB	DKH	DSI	LBI	LBH
○	○	○	○	○	○
Very small	Very small	Medium	Medium	Small	Small
Yes	Yes	No	—	—	—
No	No	No	Yes	Yes	Yes
F-108	F-110	F-113	F-116	F-119	F-121

Remark 1) Depending on the size of extrusion gap, backup ring might be necessary. Refer to Fig.D-6 on page D-6 and dimension table.

Remark 2) Applicable temperature ranges for packings and dust seals are indicated by colors for each rubber material.

	Nitrile rubber
	Nitrile rubber for low temperature
	Fluoro rubber
	Noxian (polyurethane rubber)
	Heat resistant noxian (heat resistant polyurethane rubber)



Remark 3) * mark shows the permissible maximum pressure of packing as a single piece.

Remark 4) Some small diameter type cannot be installed with internal groove.

(2) Application range of dust seals for oscillating application

Dust seals for oscillating motion are mainly used for hinge pin and bush parts. In contrast to dust seals for reciprocating motion, the shape of lip is specially designed to reduce torque and have a relief effect by rear-side greasing, this assures good performance in severe dust conditions.



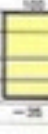













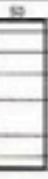
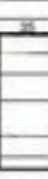
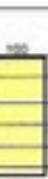
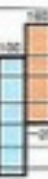
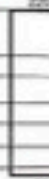
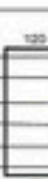

<Table> D-3 Application range of dust seals for oscillating motion

Item	Kind Type	Dust seals for sliding movement	
		DLI2	DLI
Shape			
Temperature (°C)			
Dimension table (page)		F-142	F-144

3. Application Range of Related Products for Hydraulic Equipment



Selecting the right combination of packings and related products for the specific operating conditions will insure proper sealing effectiveness.

<Table D-4> Application range of relating product for hydraulic equipment

Item	Kind Classifier Type	Special packings for rod seals		Related products for reciprocating motion						
		Buffer ring		Wear ring		Contami seals	Backup ring			
		HBY	HBTS	RYT	WR	KZT	BRT2	BRT3	BRN2	BRN3
Shape										
Pressure (MPa)				—	—	—	—	—	—	—
Temperature (°C)										
Speed (m/s)							—	—	—	—
Dimension table (page)		F-125	F-127	F-129	F-131	F-135	F-138			

Remark 1) The permissible speed is determined by the relationship with the load. Refer to PV limit curve on page D-7.

Remark 2) Permissible temperature ranges for packings and dust seals are indicated by colors for each rubber material.

	Nitrile rubber for low temperature
	Fluororubber
	Noxian (polyurethane rubber)

4. Application Range of Backup Ring

(1) The role of backup ring

If the extrusion gap is too large for the operating pressure of the packing, a heel of the packing may be damaged by extruding itself (Fig. D-1).

In such case, a backup ring is necessary to prevent extrusion of the packing and to improve the durability (Fig. D-2). Fig. D-6 on page D-6 shows the relationship between operating pressure and extrusion gap.

<Fig. D-1>

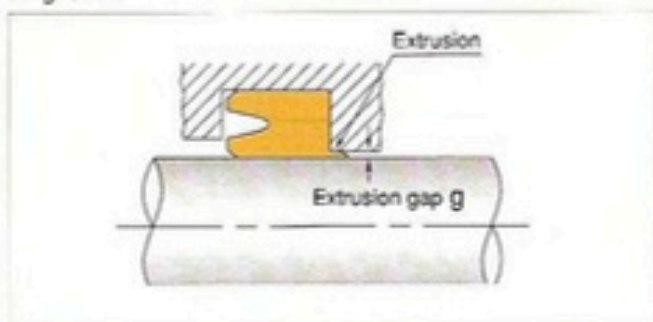

<Fig. D-2>

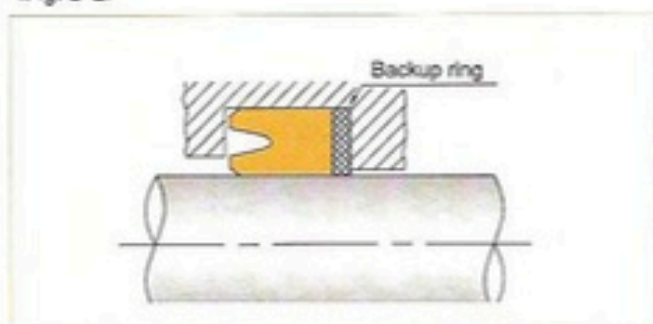

(3) Application Range of Backup Ring

Material characteristics required for a backup ring are easy compression deformation and extrusion resistance under working pressure. Friction resistance and low-friction characteristics are also important because a compressed and deformed backup ring moves in contact with the sliding surface. Considering these requirements, NOK made available two engineered plastic materials; polytetra-fluoro-ethylene (PTFE) resin (NOK rareflon) and polyamide resin. Rareflon

(2) Mechanism preventing extrusion

When the pressure is loaded, the backup ring is compressed and deformed to reduce the gap (g to g'), which prevents the extrusion of the packing heel (Fig. D-3 and 4).

<Fig. D-3>

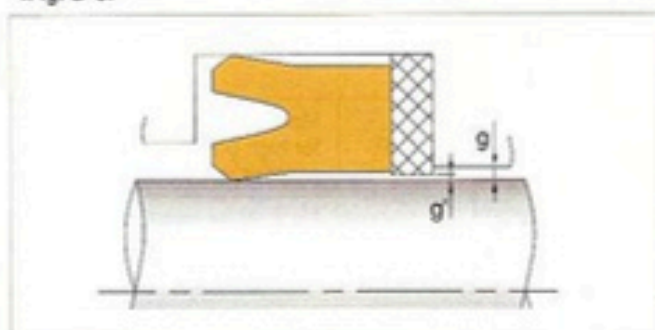

<Fig. D-4>

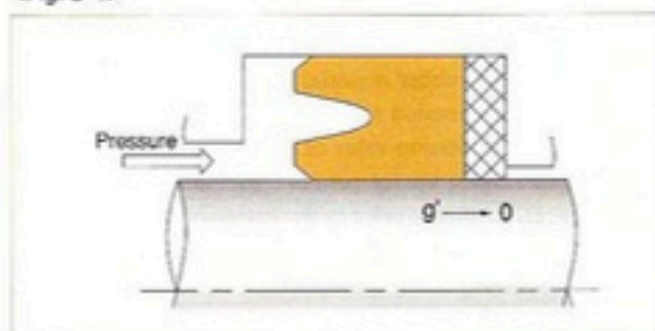

is mainly used, while polyamide resin with high rigidity against deformation is used in high pressure conditions. Table D-5 shows guidelines for material selection and Table D-6 on page D-6 shows the sign and characteristics of these materials and applicable packing type signs.

<Table D-5> Guideline for backup ring material selection

Pressure (MPa)	0	14	32	35	70
Packing material	Rareflon (polytetrafluoroethylene, PTFE, resin)		Polyamide resin		
Noxlan (polyurethane rubber)			Polyamide resin		
Nitrile, fluororubber, etc.			◆ Combination of NOK rareflon and polyamide resin (Fig. D-5)		

Remark 1) This table is a guideline for backup ring material selection. In selecting a packing, conditions other than pressure, such as extrusion gap, temperature, and packing shape, should also be considered.

Remark 2) ◆ When using this, please consult with NOK

<Fig. D-5>

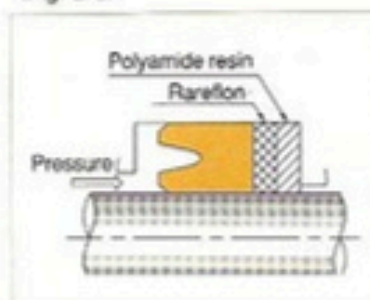

<Table D-6> Material code and characteristics of backup ring

Material	NOK material code	Features	Durability	Applicable packing type sign
Rareflon (polytetrafluoroethylene, PTFE, resin)	31BF	Low frictional resistance material with improved frictional and creep resistance against pure PTFE		OUHR UPH, USH USHR IUH
	19YF	Standard material of backup ring with high resistance against extrusion and friction under high pressure operation		
	49YF	Special material with improved extrusion resistance of 19YF		
Polyamide resin	80NP	Material with high resistance against extrusion and friction for high pressure backup ring. Its machining manufacturing process makes large diameter seals available		ODI, OSI, OUIS UPI, USI IDI, ISI, UNI
	12NM	Material for injection molding having the same performance as 80NP with smaller dimension changes by water absorption		

4) Extrusion limit

Fig. D-6 is extrusion limit curves prescribed by JOHS showing extrusions of rubber material for packings. This figure also shows the extrusion limit curves of NOK backup ring materials. The extrusion value of packings and backup rings varies depending on the temperature, pressure, and operating time. Therefore, please refer to the extrusion limit curves on

dimension tables of each type for proper application.

<Fig. D-6> Extrusion limit curves

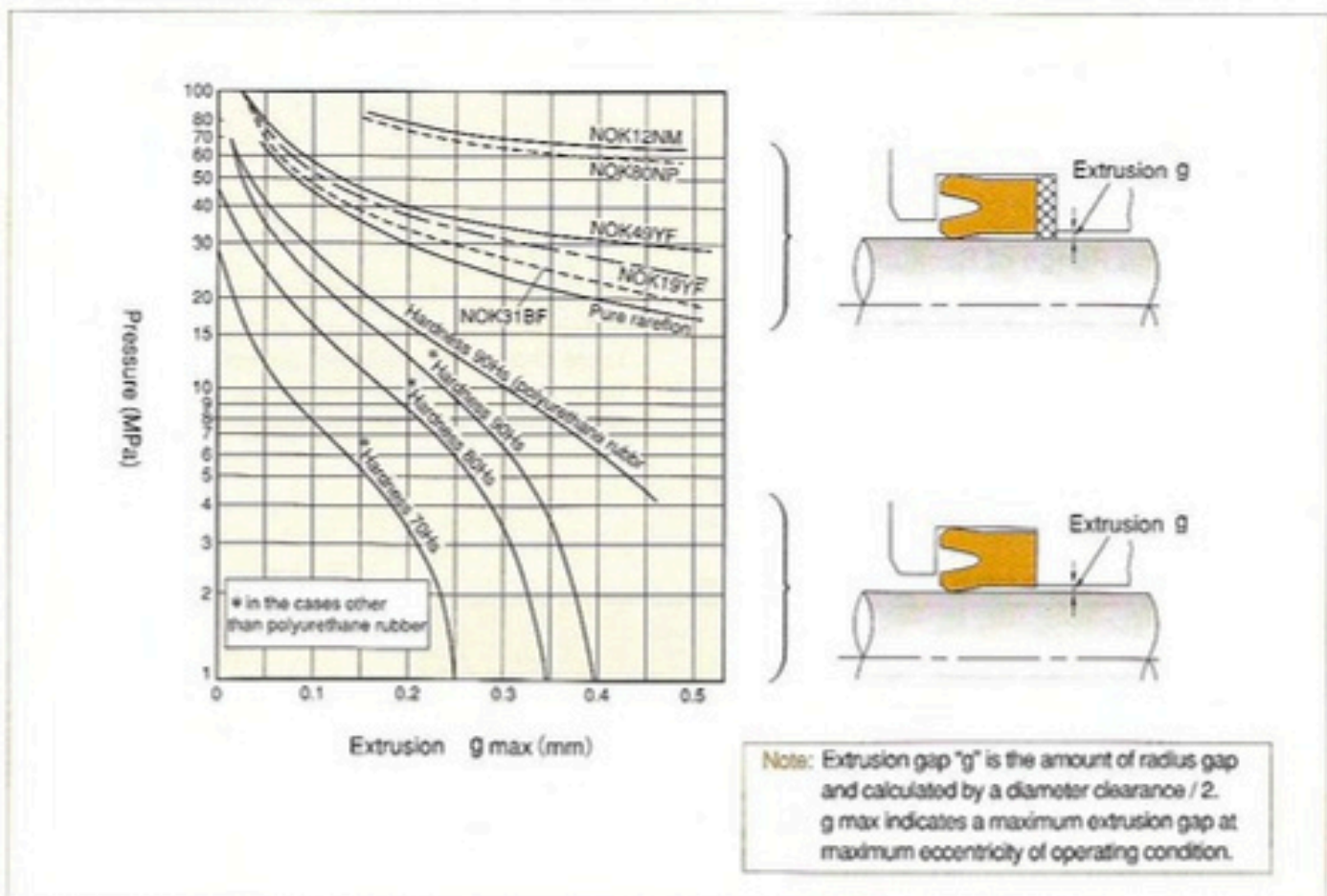

Extrusion limit may vary depending on the temperature, pressure, and operating time. Therefore, please consult NOK when using under excessive high temperature and high pressure condition for long term use.

5. Application Range of Wear Ring

(1) The role of wear rings



Wear rings are used as bearings on a piston to prevent scuffing the piston and cylinder, minimize the eccentricity, and improve the durability of packings.

(2) Selecting the wear rings

Select the shape and material of a wear ring according to the operating condition. For low speed and heavy load operations such as construction equipment, type WR with fabric reinforced phenolic resin (NOK 12RS) is recommended.

This material has excellent characteristics against compression load. For high speed and light load operations or operations where stick slip may be possible, type RYT of polytetrafluoroethylene resin (NOK Rareflon, 05ZF) is recommended. This material has excellent characteristics against friction and wear. Table D-7 shows the characteristics and application range of each wear ring type.

<Table D-7> Characteristics and application range of wear ring

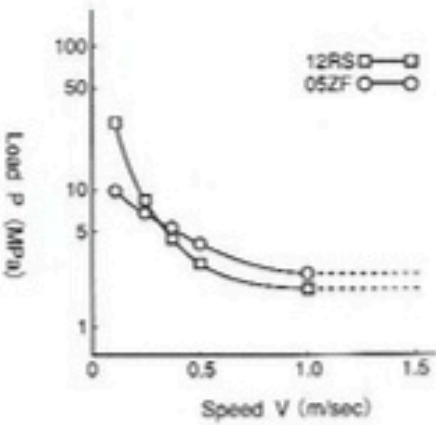
Type	RYT	WR																					
Shape																							
Material (NOK sign)	Polytetrafluoroethylene (PTFE) resin (rareflon 05ZF)	Fabric reinforced phenolic resin (12RS)																					
Characteristics	<ul style="list-style-type: none"> ● Low friction and stick slip free wear ring ● Excellent wear resistance under high speed and light load operation ● Supplied in hoop (10m/roll) enabling to be cut according to the cylinder diameter 	<ul style="list-style-type: none"> ● NOK standard wear ring having excellent compression resistance characteristics ● Excellent wear resistance under low speed and heavy load operation ● Wide range of diameter and width size are available. Each piece has one point biascut. (Sizes other than those on the dimension table are available.) ● Wear rings of rareflon (WRT) are also available. 																					
Temperature	-55 ~ 220 °C	-55 ~ 120 °C																					
Application range	Refer to the graph below for PV limit. <div style="text-align: right;"> Lubricating oil : engine oil 10W Contacting material : S45C (1.6μmR_{max}) </div>  <table border="1"> <caption>Approximate data from PV limit graph</caption> <thead> <tr> <th>Speed V (m/sec)</th> <th>Load P (MPa) - 12RS (□)</th> <th>Load P (MPa) - 05ZF (○)</th> </tr> </thead> <tbody> <tr> <td>0.1</td> <td>10</td> <td>30</td> </tr> <tr> <td>0.2</td> <td>7</td> <td>15</td> </tr> <tr> <td>0.3</td> <td>5</td> <td>10</td> </tr> <tr> <td>0.4</td> <td>4</td> <td>8</td> </tr> <tr> <td>0.5</td> <td>3.5</td> <td>6</td> </tr> <tr> <td>1.0</td> <td>2.5</td> <td>4</td> </tr> </tbody> </table>		Speed V (m/sec)	Load P (MPa) - 12RS (□)	Load P (MPa) - 05ZF (○)	0.1	10	30	0.2	7	15	0.3	5	10	0.4	4	8	0.5	3.5	6	1.0	2.5	4
Speed V (m/sec)	Load P (MPa) - 12RS (□)	Load P (MPa) - 05ZF (○)																					
0.1	10	30																					
0.2	7	15																					
0.3	5	10																					
0.4	4	8																					
0.5	3.5	6																					
1.0	2.5	4																					

(3) Dimension set up of wear rings

Various diameters and widths are available for WR (NOK 12RS) to meet different cylinder diameters and groove sizes. For further details, refer to the dimension table F-131 to 134. Please set up the width h by the formula below.

$$h_{\min} \geq \frac{F \cdot S_o}{2.05 \cdot D_c} + 2.4$$

① In case no lateral loads exist

$$F = (\text{Piston weight}) + \frac{1}{2}(\text{Rod weight}) + \frac{1}{200} \times \frac{\pi \cdot D_c^2}{4} \times P_{\max}$$

$$S_o = 1$$

② In case lateral loads exist

$$F = \frac{\ell_1}{\ell_2} \left(\frac{1}{2} \text{Rod weight} + W_{\max} \right) - (\text{Piston weight})$$

$$S_o \begin{cases} \text{In case lateral impact loads exist : 1.5} \\ \text{In case no lateral impact loads exist : 4} \end{cases}$$

h_{\min} : Minimum wear ring width size (mm)
 F : Load charged on wear ring (N)
 S_o : Safety coefficient
 D_c : Inner diameter of cylinder tube (mm)
 P_{\max} : Maximum pressure (MPa)
 W_{\max} : Maximum lateral load (N)

<Fig.D-7>

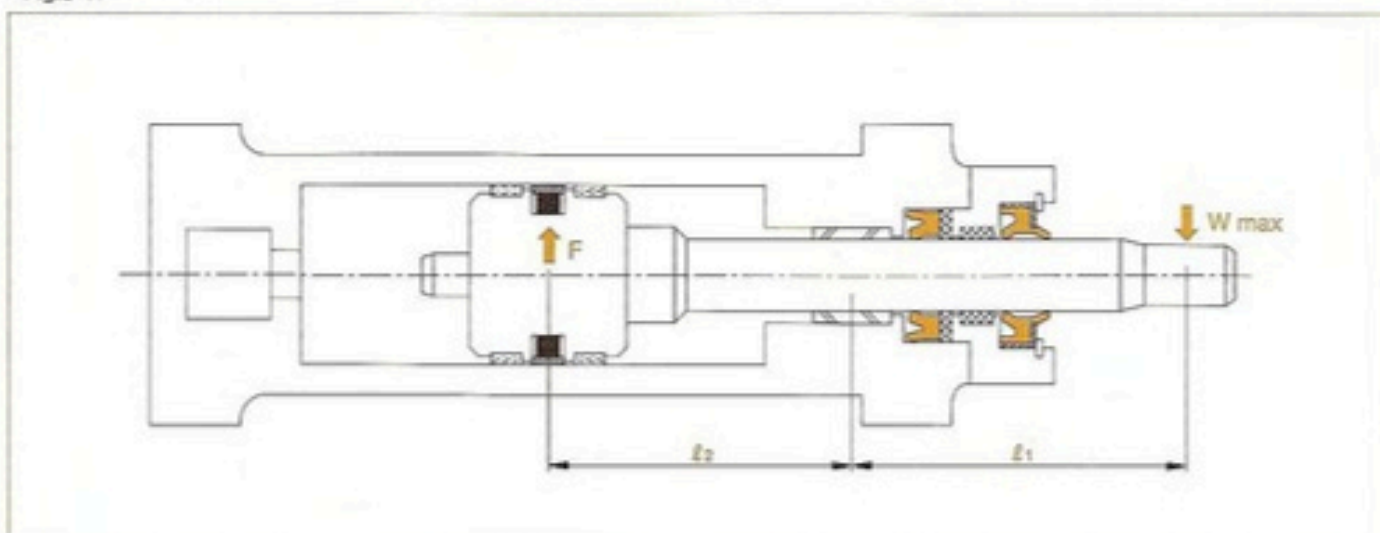

For example, if the calculation result of $\phi 100\text{mm}$ diameter shows h_{\min} 17.5mm, use two GW0332PO (WR94 \times 100 \times 15) in dimension table on page F-134 or one GW0041P3 (WR94 \times 100 \times 25) in dimension table on page F-132. Sizes other than those in the dimension table are also available upon request. Please consult NOK. (Outer diameters up to $\phi 800\text{mm}$ can be supplied.)

RYT (NOK 05ZF) can be cut to meet the inner diameter of the cylinder tube if the fitting groove size is the same. Therefore, it is not necessary to prepare a different size of wear ring according to each size of the cylinder. Please set up the width h by the formula below as the case of WR.

$$h_{\min} \geq \frac{F \cdot S_0}{1.03 \cdot D_c}$$

h_{\min} : Minimum wear ring width size (mm)
 F : Load charged on wearing (N)
 S_0 : Safety coefficient
 D_c : Inner diameter of cylinder tube (mm)

Cutting length L to meet the inner diameter of cylinder tube can be obtained by the formula below.

$$L = \pi \cdot (D_c - t) - S$$

D_c : Inner diameter of cylinder tube (mm)
 t : Thickness of wear ring (mm)
 S : Wear ring gap (mm)

Remark) Refer to the dimension table on page F-129 for t and S .

<Fig.D-8>

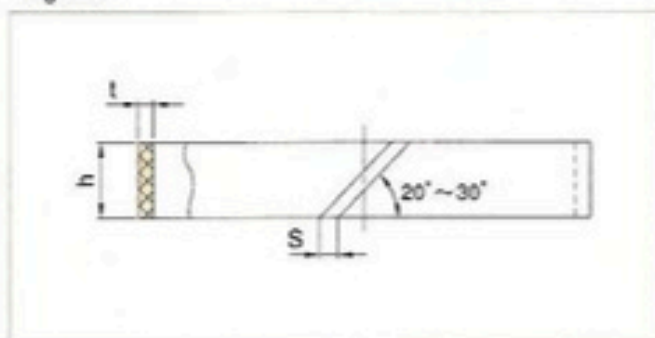

Sizes other than those in the dimension table are also available upon request. Besides, the single piece of wear ring shown in Fig. D-9 is also available. Please consult NOK.

<Fig. D-9>

Type and shape		
WRT	WRT1	WRT2

Selecting Type

1. Correlation of Packing Types

NOK provides a wide variety of seals to meet various operating conditions. The following charts will assist in selection of appropriate packings and seals. To meet a wide variety of our customer's needs, we have developed a sealing system using a

(1) Rod seals

Using buffer ring to the rod seal is effective to buffer impact pressure, suppress oil temperature transmission, and reduce sliding heat, which results in improved durability of the packings.

Remarks) About horizontal bar graphs beneath the type sign
 ● The values on both ends represent applicable temperature range.
 ○ The items in ○ are of special specifications and not listed on the dimension table.

<Fig. D-10> Correlation chart of each packing type

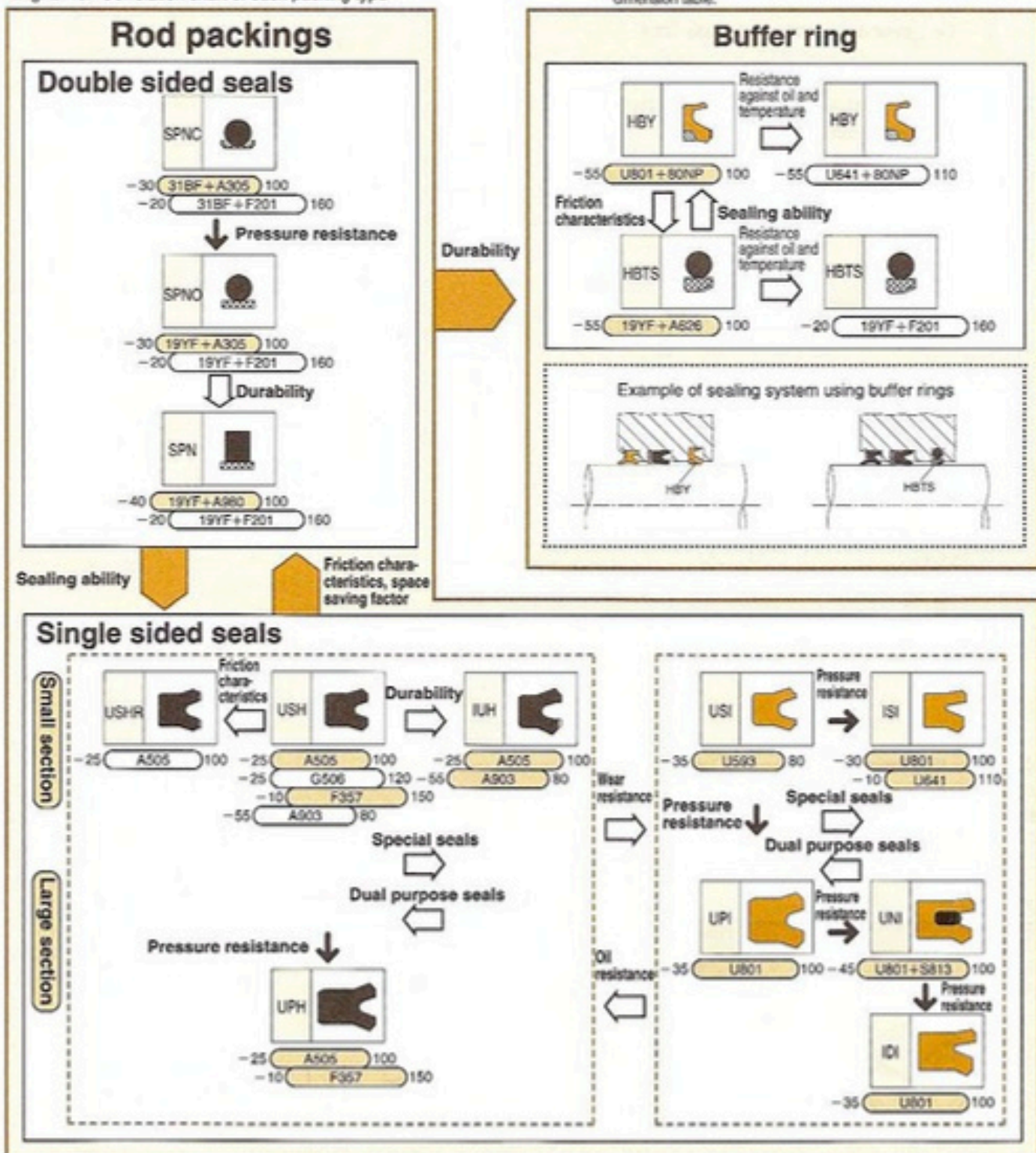

combination of buffer rings and contami seals offering excellent reliability and durability. Please refer to chapter E for application examples of sealing systems, and pages D-2 and 3 for selection of each type.

(2) Piston seals

Using a contami seal with the piston seal is effective to prevent damage caused by foreign objects and isentropic compression, which results in improved durability of packings.

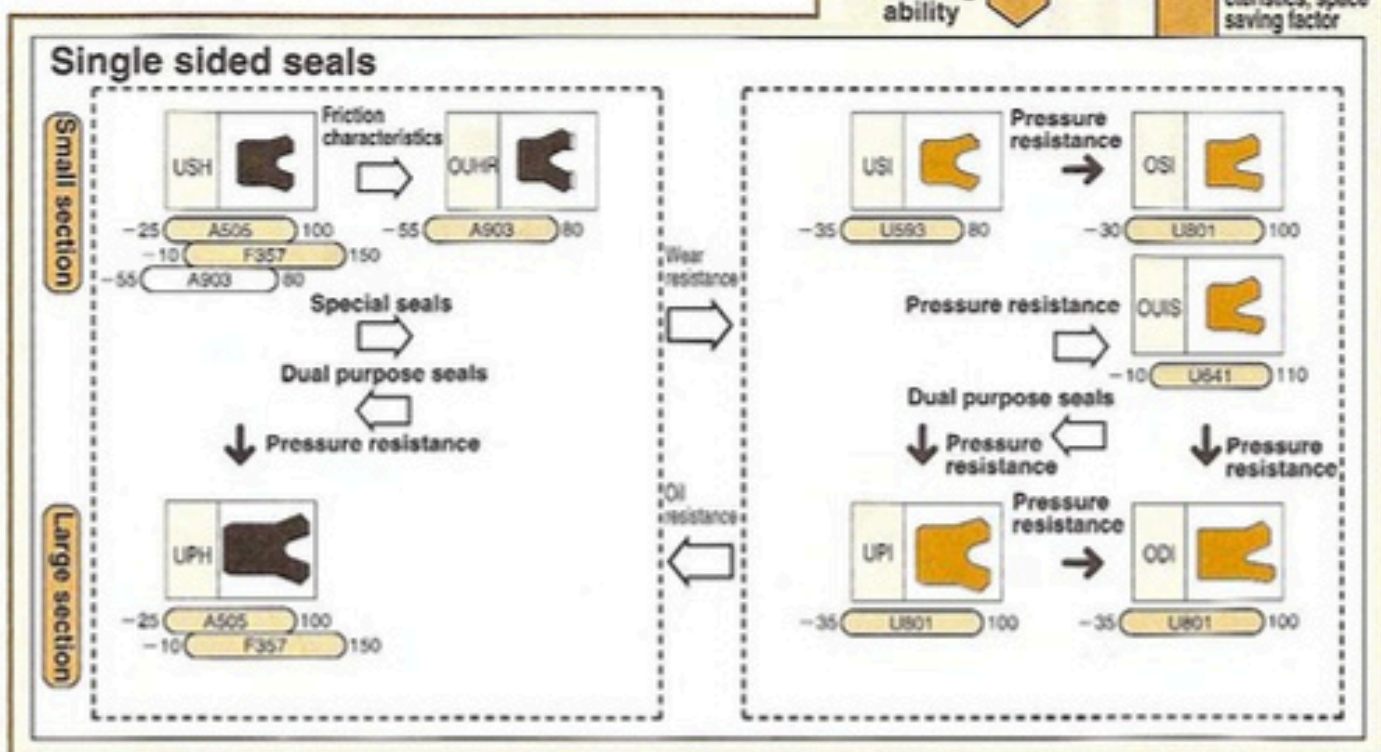
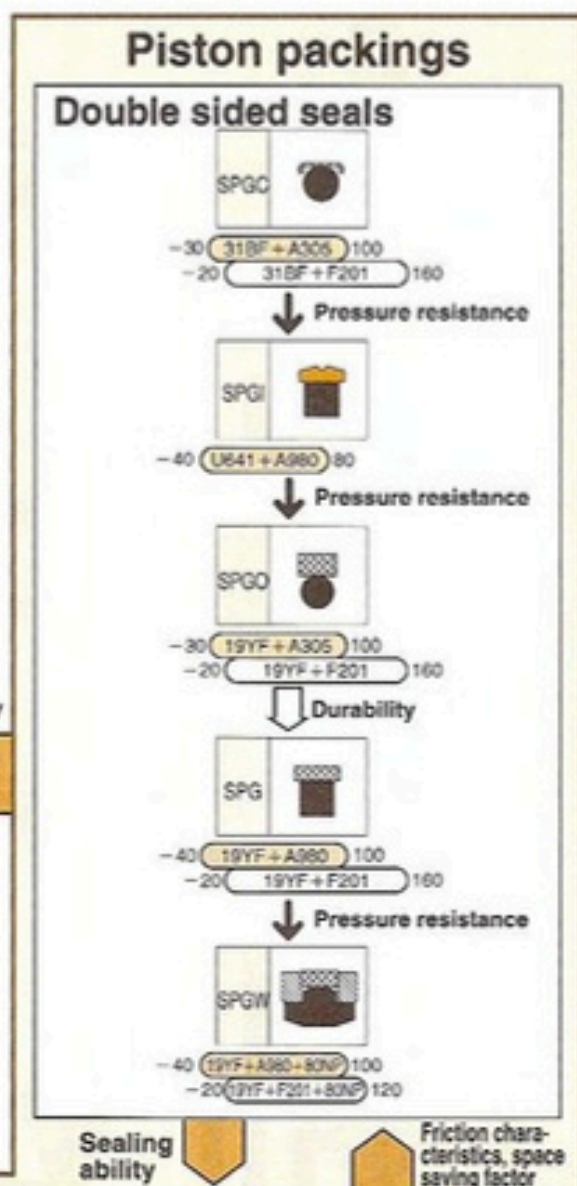
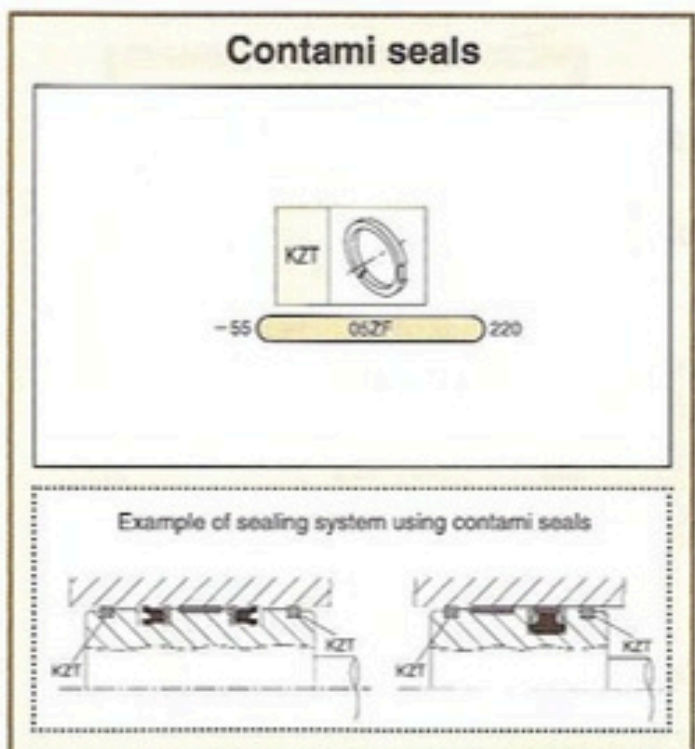

Wear resistance →

Oil resistance ←

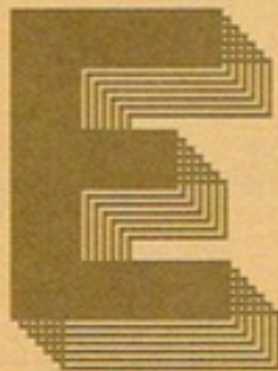

APPLICATION EXAMPLES OF NOK PACKING

**JIS Standard Cylinder
Application Examples** E-3-5

**Application Examples by
Equipments** E-6-17

E. APPLICATION EXAMPLES OF NOK PACKING

The following classification shows typical application examples of various hydraulic equipment seals, including packings for reciprocal movement, dust seals for sliding and rotating movement, and oil seals. These examples are NOK's recommended applications based on its significant experience in the market. Some special types without dimension tables are introduced here. If any types and materials with unique specifications are required, please consult NOK.

Classification of Application Example

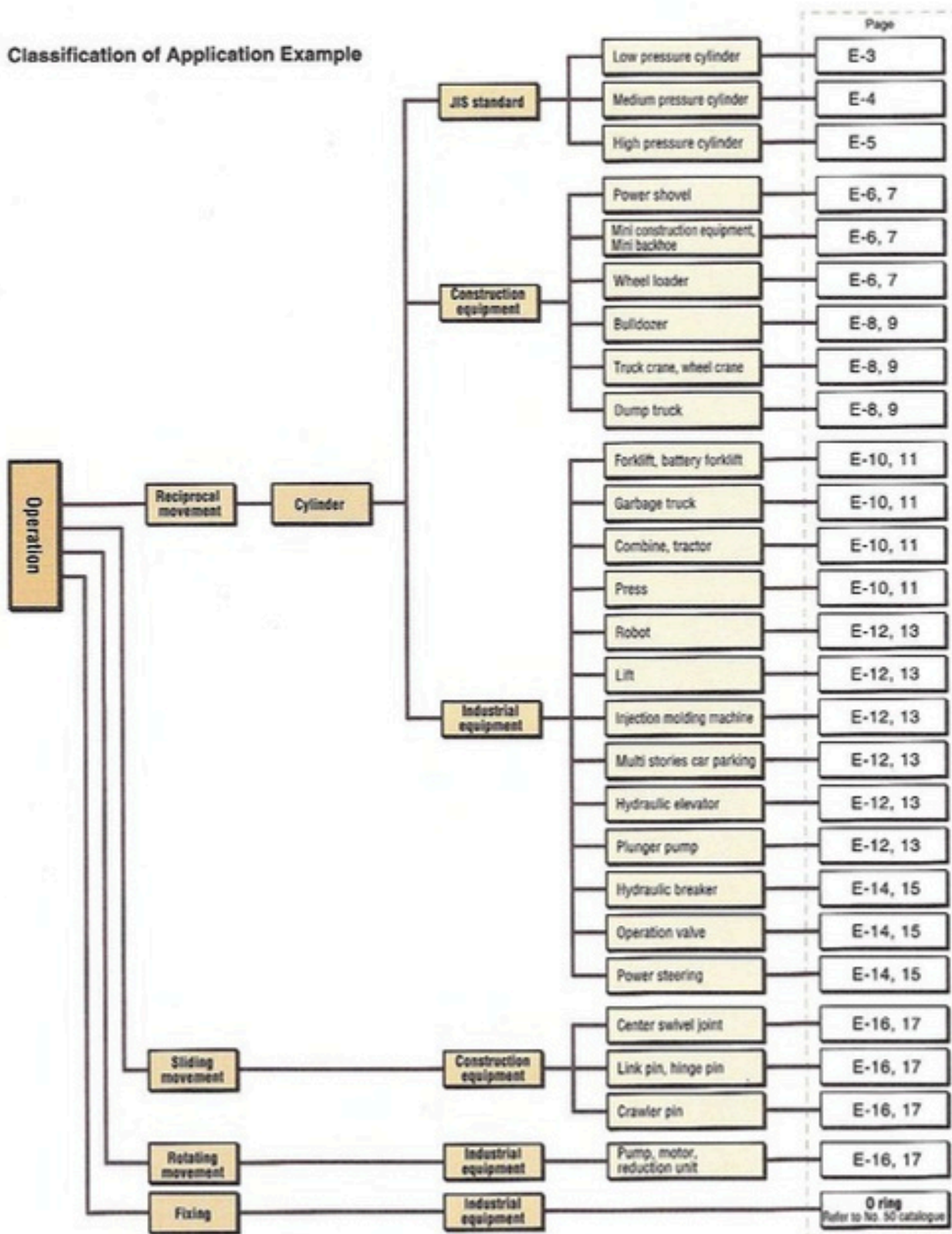

JIS Standard Cylinder (JIS B 8354)

Hydraulic cylinder for low pressure : 7 MPa or less

◆ Applicable temperature range of the cylinder :

Standard specifications	-20 ~ 80 °C
Heat resistant specifications	-10 ~ 120 °C
Low temperature specifications	-55 ~ 60 °C

◆ According to JIS B 8354, the ambient temperature range is prescribed from -5 to 80°C. NOK, however, provides packings applicable for a wider range of temperature.

Remark) Items having — sign in the column of dimension table indicate special specifications. If the data of such items are required, please consult NOK.

Recommended example 1

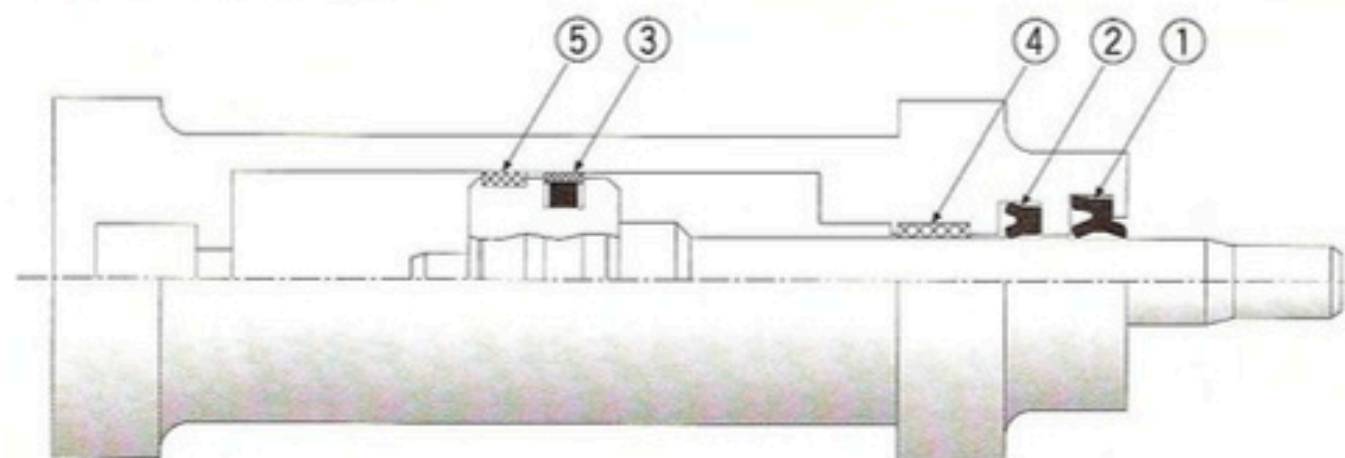

Item	Standard specifications			Heat resistant specifications			Low temperature specifications			To reduce the sliding friction, the SPG is employed for the piston packing and small section U packing for rod packing. For the dust seal of low temperature application, instead of LBH, we recommend DKB with a metal case that has low shrinkage percentage of diameter at low temperature.
	Type	Material code	Dimension table (page)	Type	Material code	Dimension table (page)	Type	Material code	Dimension table (page)	
① Dust seal	LBH	A505	F-121	LBH	F357	F-121	DKB	A980 SPCC	—	
② Rod packing	USH	A505	F-85	USH	F357	F-85	IUH	A903	F-52	
③ Piston packing	SPG	19YF A980	F-19	SPG	19YF F201	—	SPG	19YF A980	F-19	
④ Wear ring	RYT	05ZF	F-129	RYT	05ZF	F-129	RYT	05ZF	F-129	
⑤ Wear ring	RYT	05ZF	F-129	RYT	05ZF	F-129	RYT	05ZF	F-129	

Recommended example 2

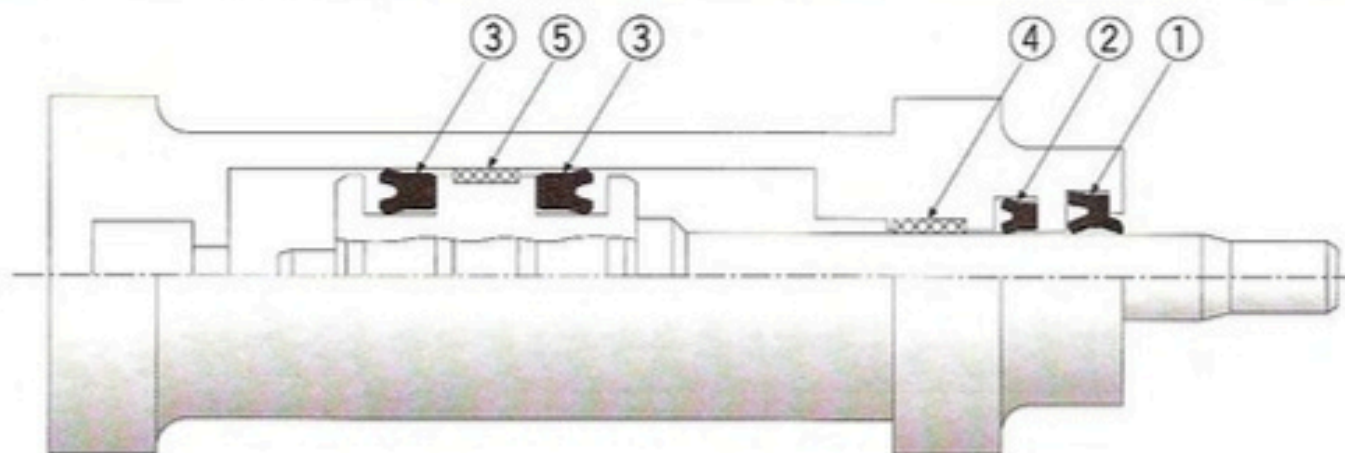

Item	Standard specifications			Heat resistant specifications			Low temperature specifications			The U packings are employed to improve the sealing ability of piston. For the dust seal of low temperature application, instead of LBH, we recommend DKB with a metal case that has low shrinkage percentage of diameter at low temperature.
	Type	Material code	Dimension table (page)	Type	Material code	Dimension table (page)	Type	Material code	Dimension table (page)	
① Dust seal	LBH	A505	F-121	LBH	F357	F-121	DKB	A980 SPCC	—	
② Rod packing	USH	A505	F-85	USH	F357	F-85	IUH	A903	F-52	
③ Piston packing	USH	A505	F-85	USH	F357	F-85	OUHR	A903	F-16	
④ Wear ring	RYT	05ZF	F-129	RYT	05ZF	F-129	RYT	05ZF	F-129	
⑤ Wear ring	RYT	05ZF	F-129	RYT	05ZF	F-129	RYT	05ZF	F-129	

JIS Standard Cylinder (JIS B 8354)

Hydraulic cylinder for medium pressure : 14 MPa or less

◆ Applicable temperature range of the cylinder :

Standard specifications	-20 ~ 80 °C
Heat resistant specifications	-10 ~ 120 °C
Low temperature specifications	-55 ~ 60 °C

⊙ According to JIS B 8354, the ambient temperature range is prescribed from -5 to 80°C. NOK, however, provides packings applicable for a wider range of temperature.

Remark) Items having — sign in the column of dimension table indicate special specifications. If the data of such items are required, please consult NOK.

Recommended example 3

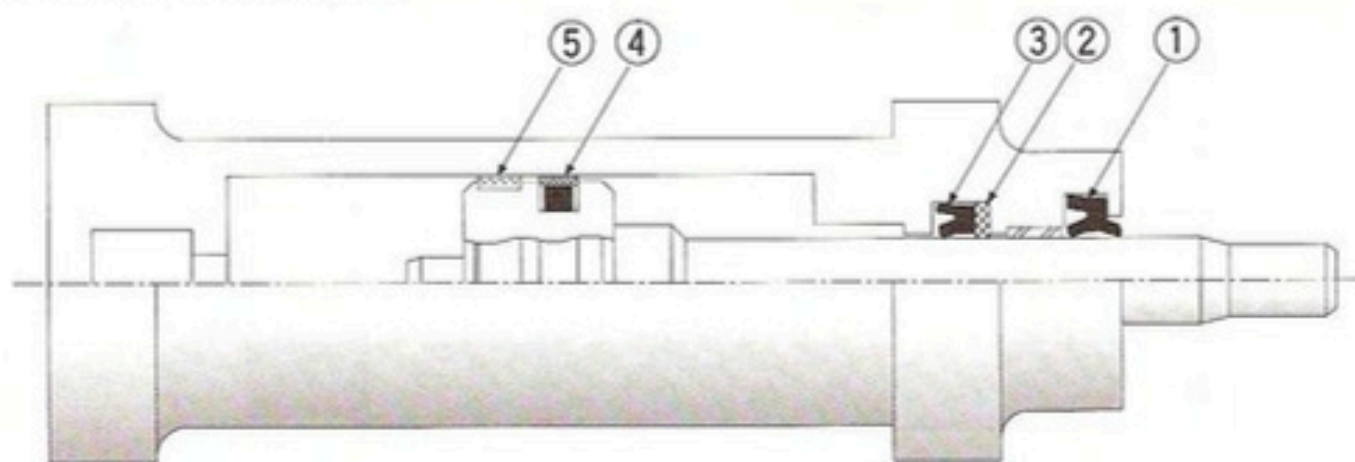

Item	Standard specifications			Heat resistant specifications			Low temperature specifications			The low friction SPG packing and high load durability wear ring are employed for the piston. For the dust seal of low temperature application, instead of LBH, we recommend DKB with a metal case that has low shrinkage percentage of diameter at low temperature.
	Type	Material code	Dimension table (page)	Type	Material code	Dimension table (page)	Type	Material code	Dimension table (page)	
① Dust seal	LBH	A505	F-121	LBH	F357	F-121	DKB	A980 SPCC	—	
② Backup ring	BRT2	19YF	F-138	BRT2	19YF	F-138	BRT2	19YF	F-138	
③ Rod packing	USH	A505	F-85	USH	F357	F-85	IUH	A903	F-52	
④ Piston packing	SPG	19YF A980	F-19	SPG	19YF F201	—	SPG	19YF A980	F-19	
⑤ Wear ring	WR	12RS	F-131	WR	12RS	F-131	WR	12RS	F-131	

Recommended example 4

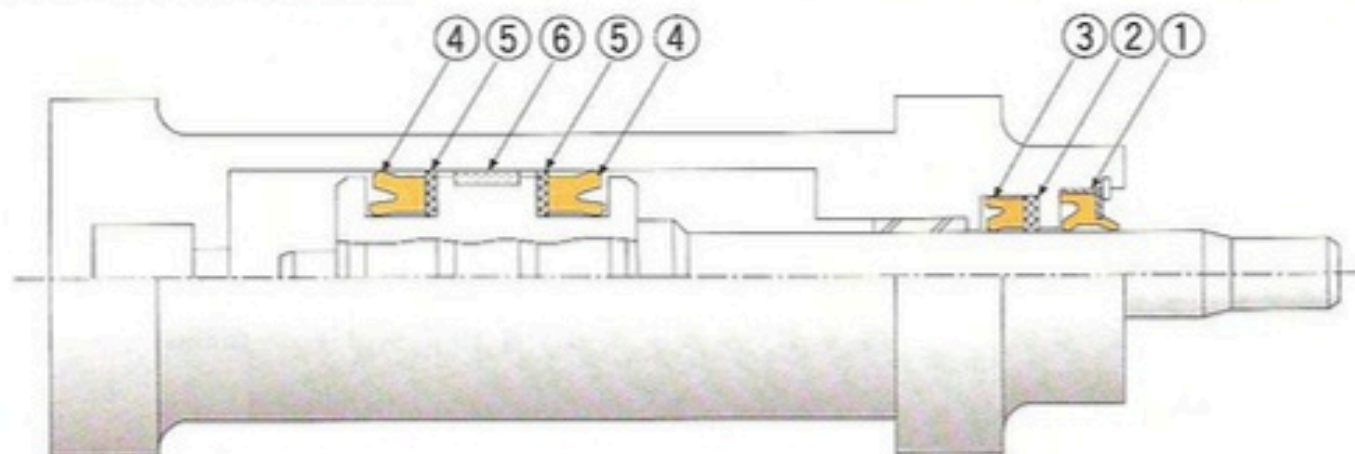

Item	Standard specifications			Heat resistant specifications			Low temperature specifications			The U packings are employed to improve the sealing ability of piston.
	Type	Material code	Dimension table (page)	Type	Material code	Dimension table (page)	Type	Material code	Dimension table (page)	
① Dust seal	DKBI	U801 SPCC	F-108	LBH	F357	F-121	DKB	A980 SPCC	—	
② Backup ring	—	—	—	BRT2	19YF	F-138	BRT2	19YF	F-138	
③ Rod packing	ISI	U801	F-49	USH	F357	F-85	IUH	A903	F-52	
④ Piston packing	OSI	U801	F-11	USH	F357	F-85	OUHR	A903	F-16	
⑤ Backup ring	—	—	—	BRT2	19YF	F-138	BRT2	19YF	F-138	
⑥ Wear ring	WR	12RS	F-131	WR	12RS	F-131	WR	12RS	F-131	

JIS Standard Cylinder (JIS B 8354)

Hydraulic cylinder for high pressure : 21 MPa or less

◆ Applicable temperature range of the cylinder :

Standard specifications	-20 ~ 80°C
Heat resistant specifications	-10 ~ 120°C
Low temperature specifications	-55 ~ 60°C

◆ According to JIS B 8354, the ambient temperature range is prescribed from -5 to 80°C. NOK, however, provides packings applicable for a wider range of temperature.

Remark) Items having — sign in the column of dimension table indicate special specifications. If the data of such items are required, please consult NOK.

Recommended example 5

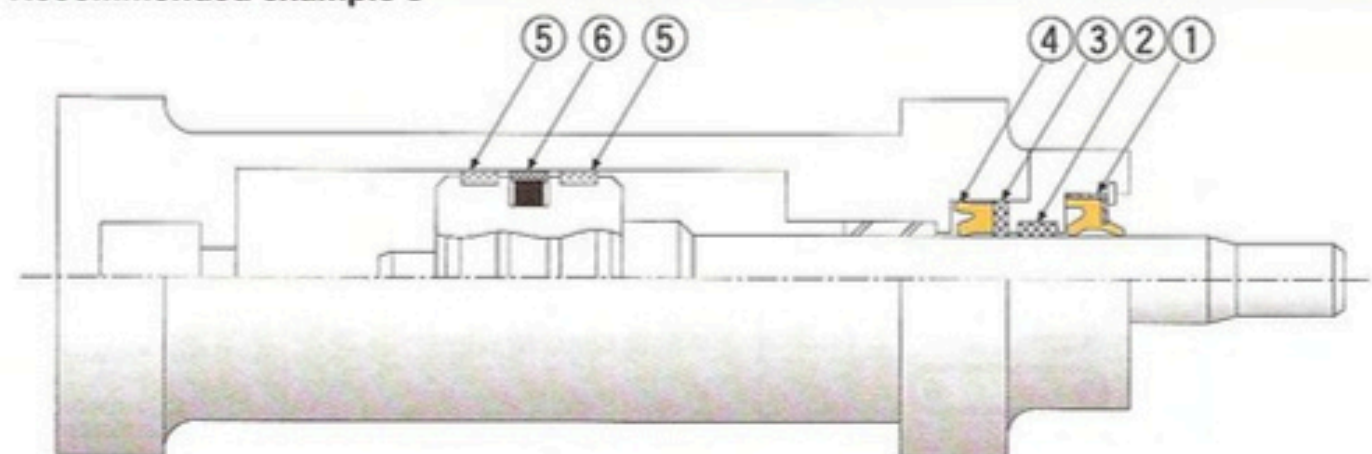

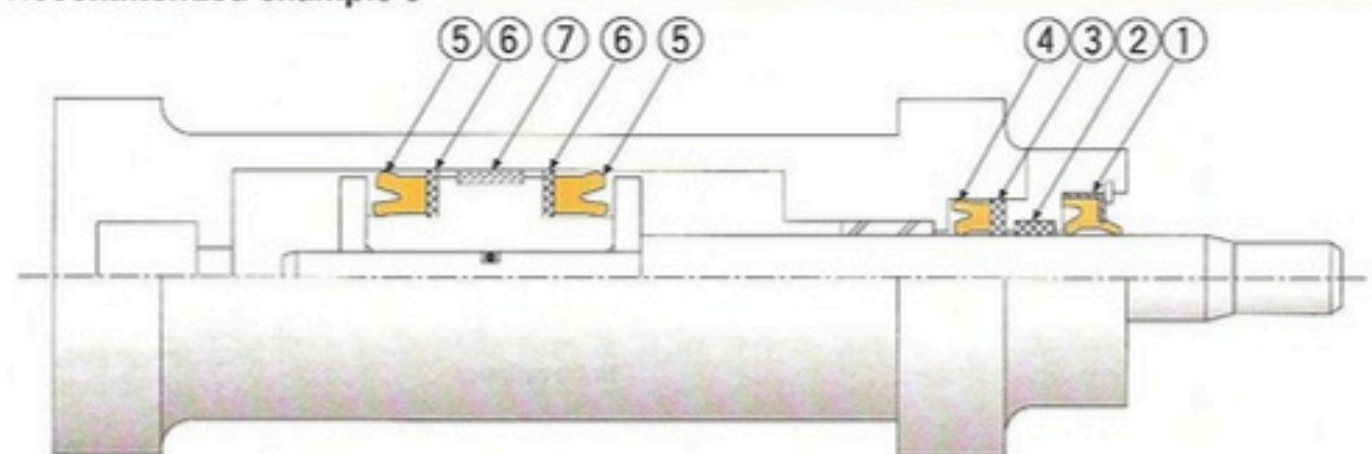

Item	Standard specifications			Heat resistant specifications			Low temperature specifications			The low friction SPG packing and the high load durability wear ring are employed for the piston. The large section U packing are employed for the rod packing considering its high durability.
	Type	Material code	Dimension table (page)	Type	Material code	Dimension table (page)	Type	Material code	Dimension table (page)	
① Dust seal	DKBI	U801 SPCC	F-108	LBH	F357	F-121	DKBI	U801 SPCC	F-108	
② Wear ring	RYT	05ZF	F-129	RYT	05ZF	F-129	RYT	05ZF	F-129	
③ Backup ring	—	—	—	BRT2	19YF	F-138	BRT2	19YF	F-138	
④ Rod packing	IDI	U801	F-41	UPH	F357	F-77	UPH	A903	F-77	
⑤ Wear ring	WR	12RS	F-131	WR	12RS	F-131	WR	12RS	F-131	
⑥ Piston packing	SPG	19YF A980	F-19	SPG	19YF F201	F-19	SPG	19YF A980	F-19	

Recommended example 6







Item	Standard specifications			Heat resistant specifications			Low temperature specifications			The U packings are employed to improve the sealing ability of piston.
	Type	Material code	Dimension table (page)	Type	Material code	Dimension table (page)	Type	Material code	Dimension table (page)	
① Dust seal	DKBI	U801 SPCC	F-108	LBH	F357	F-121	DKBI	U801 SPCC	F-108	
② Wear ring	RYT	05ZF	F-129	RYT	05ZF	F-129	RYT	05ZF	F-129	
③ Backup ring	—	—	—	BRT2	19YF	F-138	BRT2	19YF	F-138	
④ Rod packing	IDI	U801	F-41	UPH	F357	F-77	UPH	A903	—	
⑤ Piston packing	ODI	U801	F-3	UPH	F357	F-77	UPH	A903	—	
⑥ Backup ring	—	—	—	BRT2	19YF	F-138	BRT2	19YF	F-138	
⑦ Wear ring	WR	12RS	F-131	WR	12RS	F-131	WR	12RS	F-131	

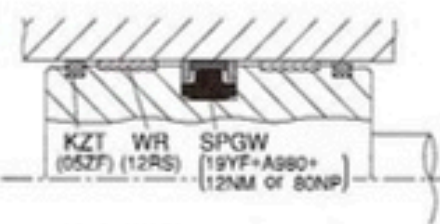
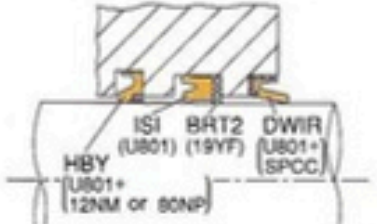
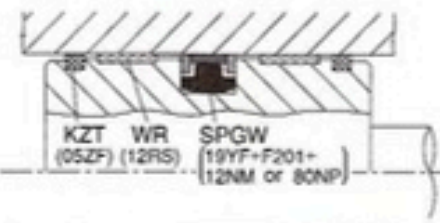
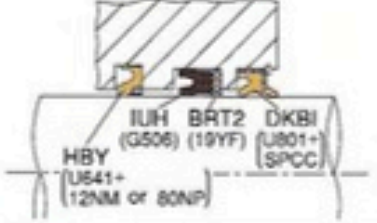
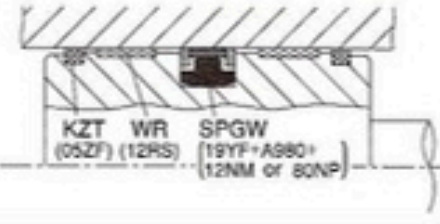
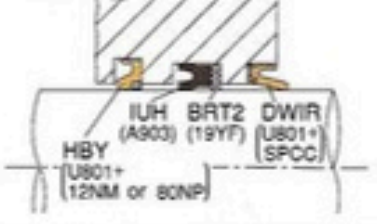
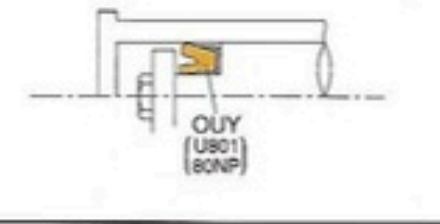
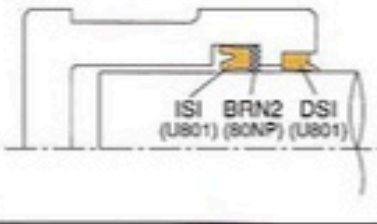
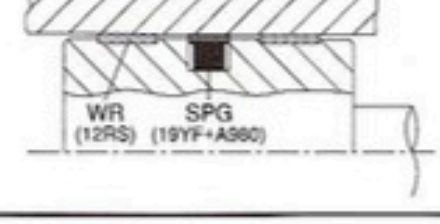
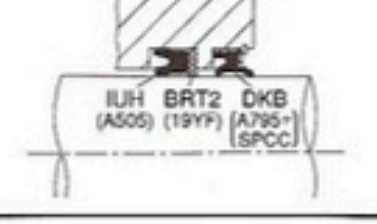
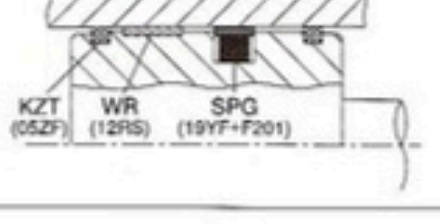
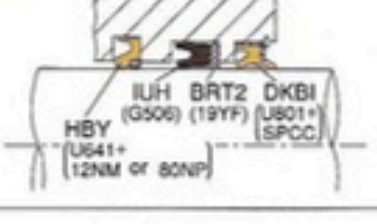
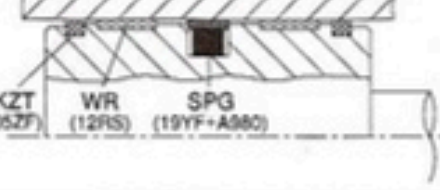
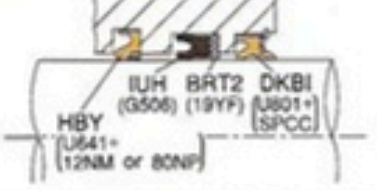



Application Examples by Equipment





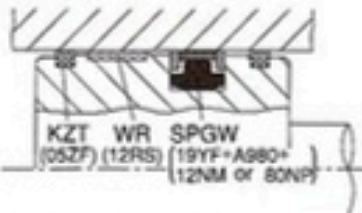

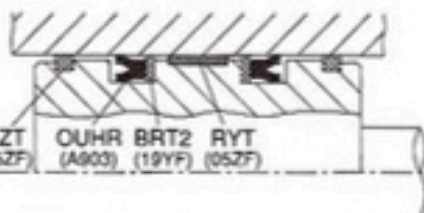
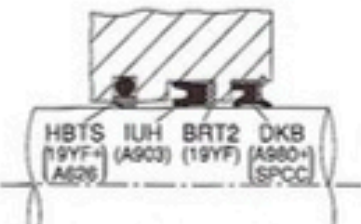
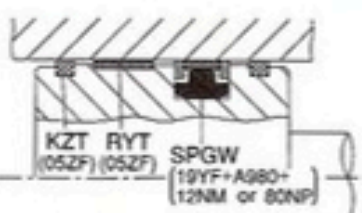
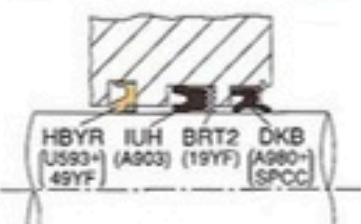
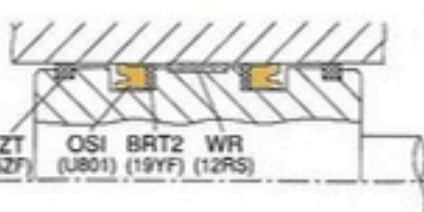
Equipment	Application	Operating condition
 <p>Power shovel</p>		Standard specifications 0~31.4MPa (0~320kgf/cm ²) -30~100℃
	Boom cylinder Arm cylinder Bucket cylinder	Heat resistance specifications 0~31.4MPa (0~320kgf/cm ²) -30~120℃
		Cold resistance specifications 0~31.4MPa (0~320kgf/cm ²) -50~80℃
	Adjust cylinder (grease cylinder)	0~78.5MPa (0~800kgf/cm ²) -30~100℃
 <p>Mini construction equipment Mini back hoe</p>	Boom cylinder Arm cylinder Bucket cylinder Blade cylinder	0~20.6MPa (0~210kgf/cm ²) -30~100℃
 <p>Wheel loader</p>	Hoist cylinder Bucket cylinder	0~20.6MPa (0~210kgf/cm ²) -30~110℃
	Steering cylinder	0~20.6MPa (0~210kgf/cm ²) -30~110℃

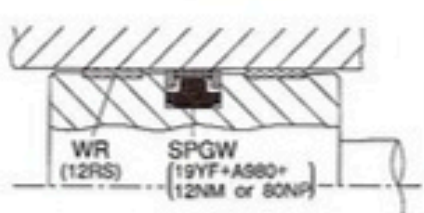
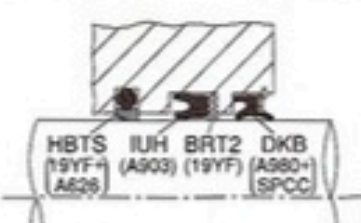
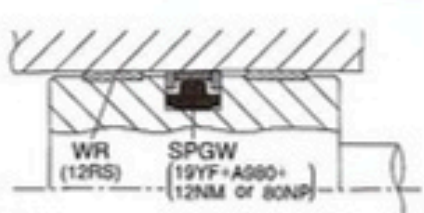
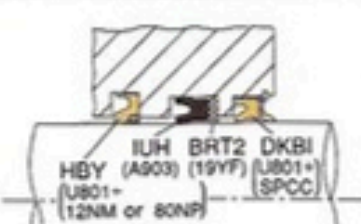
Piston sealing system	Feature	Rod sealing system	Feature
 <p>KZT (05ZF) WR (12RS) SPGW (19YF+A980+ (12NM or 80NP))</p>	High durability for severe operating condition with the selected materials; SPGW that is applicable for high pressure and KZT that removes foreign objects in hydraulic fluid oil and prevents seal damages caused by adiabatic compression	 <p>ISI (U801) BRT2 (19YF) DWIR (U801+ (SPCC)) HBY (U801+ (12NM or 80NP))</p>	HBY is used to assure the longevity of rod seals and its combination with DWIR prevents oil scraping off.
 <p>KZT (05ZF) WR (12RS) SPGW (19YF+F201+ (12NM or 80NP))</p>	Fluoro rubber(F201) is applied to the back ring of SPGW to enable high temperature operation.	 <p>IUH (G506) BRT2 (19YF) DKBI (U801+ (SPCC)) HBY (U641+ (12NM or 80NP))</p>	Heat resistant polyurethane rubber(U641) is used to HBY and hydrogenated NBR (G506) to rod seals. Oil scraping off can be prevented by using DKBI.
 <p>KZT (05ZF) WR (12RS) SPGW (19YF+A980+ (12NM or 80NP))</p>	Standard material for back ring of SPGW is low temperature resistant nitrile rubber.	 <p>IUH (A903) BRT2 (19YF) DWIR (U801+ (SPCC)) HBY (U801+ (12NM or 80NP))</p>	Low temperature resistant nitrile rubber(A903) is used for IUH.
 <p>OUY (U801) (80NP)</p>	Special seal for piston OUY is used to enable the operation of extremely short strokes under high pressure (under such operation, oil film can be broken with ordinary seals).	 <p>ISI (U801) BRN2 (80NP) DSI (U801)</p>	Because of small operation range of pressure, ISI is used in combination with backup ring of polyamide resin(80NP) of high extrusion proof characteristics.
 <p>WR (12RS) SPG (19YF+A980)</p>	Compact SPG for medium pressure is used. Two WR are used to prevent scoring between the piston head and the cylinder tube that can be caused by high lateral load typical for such operating condition.	 <p>IUH (A505) BRT2 (19YF) DKBI (A795+ (SPCC))</p>	Nitrile rubber with high oil resistance (A505) and backup ring (19YF) are used for IUH. DKBI is used for dust seals considering its advantage preventing oil scraping off.
 <p>KZT (05ZF) WR (12RS) SPG (19YF+F201)</p>	Compact SPG for medium pressure is used. For hoist and bucket cylinder for which high temperature working characteristics are important, fluoro rubber (F201) is used for back ring material. For steering cylinder for which cold temperature working characteristics are important, low temperature resistant nitrile rubber (A980) is used.	 <p>IUH (G506) BRT2 (19YF) DKBI (U801+ (SPCC)) HBY (U641+ (12NM or 80NP))</p>	HBY (U641 + 80NP) is used to prevent sliding heat increase at the packings. Hydro NBR (G506) is used for IUH.
 <p>KZT (05ZF) WR (12RS) SPG (19YF+A980)</p>	Compact SPG for medium pressure is used. For hoist and bucket cylinder for which high temperature working characteristics are important, fluoro rubber (F201) is used for back ring material. For steering cylinder for which cold temperature working characteristics are important, low temperature resistant nitrile rubber (A980) is used.	 <p>IUH (G506) BRT2 (19YF) DKBI (U801+ (SPCC)) HBY (U641+ (12NM or 80NP))</p>	Because of wide operation range of pressure, HBY (U641 + 80NP) is used. Hydrogenated NBR (G506) is used for IUH.

Equipment	Application	Operating condition
 Bulldozer	Hoist cylinder Blade cylinder	0~20.6MPa (0~210kgf/cm ²) -30~100℃
 Truck crane  Wheel crane	Derricking cylinder Telescopic cylinder Slide cylinder	0~20.6MPa (0~210kgf/cm ²) -40~80℃
		0~31.4MPa (0~320kgf/cm ²) -30~100℃
	Jack cylinder	0~31.4MPa (0~320kgf/cm ²) -30~100℃
	Hydraulic suspension cylinder	0~20.6MPa (0~210kgf/cm ²) -30~100℃
 Dump truck	Dump cylinder	0~41.2MPa (0~420kgf/cm ²) -50~100℃





Application Examples by Equipment

Piston sealing system	Feature	Rod sealing system	Feature
 <p>KZT (05ZF) WR (12RS) SPGW (19YF+A980+ 12NM or 80NP)</p>	<p>SPGW is used because of high impact pressure. KZT is used for both ends to prevent heat damage of packings by adiabatic compression.</p>	 <p>ISI (U801) BRT2 (19YF) DKBI (U801+ SPCC)</p>	<p>Backup ring is used in combination with ISI to prevent extrusion. DKBI is used for dust seal to prevent oil scraping off.</p>
 <p>KZT (05ZF) OUHR (A903) BRT2 (19YF) RYT (05ZF)</p>	<p>OUHR with stick slip proof characteristics is used considering the operating condition that requires to keep working pressure for a long time. O5ZF having small friction resistance is used for the material of wear ring.</p>	 <p>HBTS (19YF+) (A903) IUH (A903) BRT2 (19YF) DKB (A980+) (SPCC)</p>	<p>HBTS is also used to prevent stick slip.</p>
 <p>KZT (05ZF) RYT (05ZF) SPGW (19YF+A980+ 12NM or 80NP)</p>	<p>SPGW is used because of high pressure operating condition. O5ZF having small friction resistance is used for the material of wear ring to prevent stick slip. KZT is used to prevent heat damage of the seals. By the combination of all above features, this system is excellent for severe operating condition.</p>	 <p>HBYR (U593+) (A903) IUH (A903) BRT2 (19YF) DKB (A980+) (SPCC)</p>	<p>Specially designed HBYR absorbs surge pressure for assuring high longevity of rod seals.</p>
 <p>KZT (05ZF) OSI (U801) BRT2 (19YF) WR (12RS)</p>	<p>OSI is used in combination with backup ring to improve the sealing ability.</p>	 <p>USI (U593) BRN2 (80NP) DKB (A980+) (SPCC)</p>	<p>USI with high sealing ability under low pressure is used. DKB (A980) used for dust seals has high sealing ability in low temperature and excellent characteristics to prevent oil scraping off.</p>
 <p>WR (12RS) SPGW (19YF+A980+ 12NM or 80NP)</p>	<p>SPGW is used to meet the operating condition that requires durability against impact pressure and extremely short strokes.</p>	 <p>HBTS (19YF+) (A903) IUH (A903) BRT2 (19YF) DKB (A980+) (SPCC)</p>	<p>To reduce the damage to rod seals, HBTS is used. IUH (A903) with high sealing ability in low temperature is also used.</p>
 <p>WR (12RS) SPGW (19YF+A980+ 12NM or 80NP)</p>	<p>For the operating condition that requires extremely high pressure, SPGW is used. Two WR are used considering lateral load that is typical for such operating condition.</p>	 <p>IUH (A903) BRT2 (19YF) DKBI (U801+) (SPCC) HBY (U801+ 12NM or 80NP)</p>	<p>Considering the extremely high operating pressure, HBY is used to reduce damage to rod seals. IUH (A903) with high sealing ability in low temperature is used.</p>

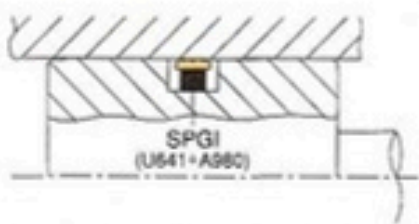
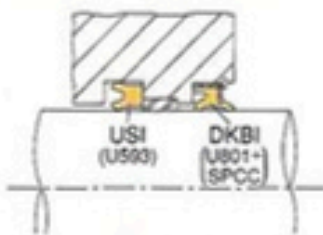
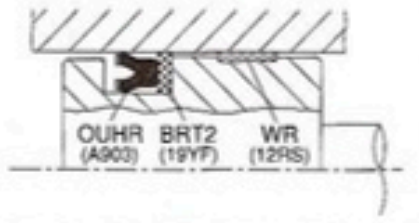
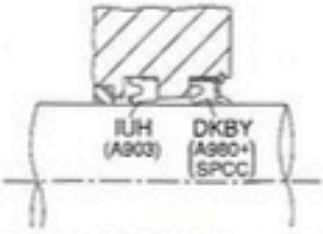
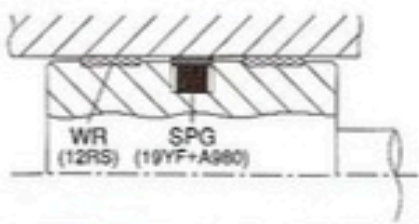
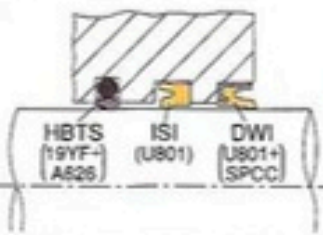
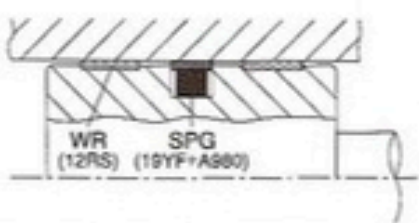
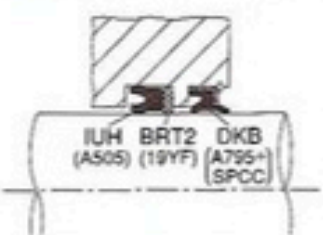
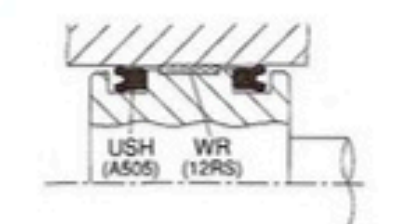
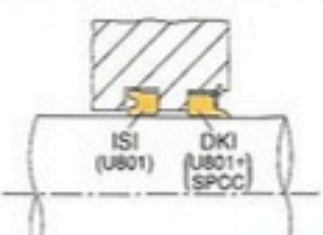
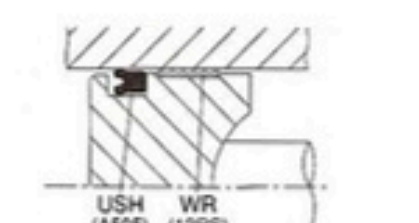
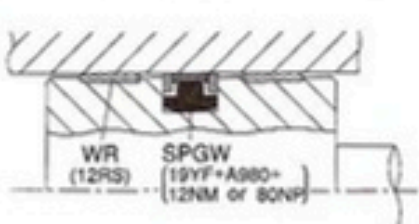
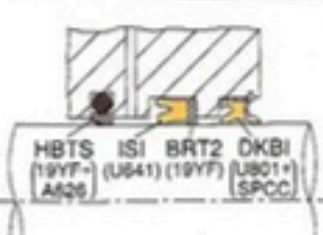

Equipment	Application	Operating condition
 Forklift  Battery forklift	Tilt cylinder	0~20.6MPa (0~210kgf/cm ²) -30~100℃
	Lift cylinder (low temperature specifications)	0~9.8MPa (0~100kgf/cm ²) -55~80℃
	Steering cylinder	0~20.6MPa (0~210kgf/cm ²) -30~100℃
 Garbage truck	—	0~20.6MPa (0~210kgf/cm ²) -30~100℃
 Combine  Farm tractor	Double acting cylinder	0~13.7MPa (0~140kgf/cm ²) -30~100℃
	Single acting cylinder	0~13.7MPa (0~140kgf/cm ²) -30~100℃
 Pressing machine	—	0~27.5MPa (0~280kgf/cm ²) -10~80℃

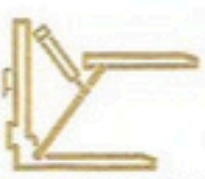

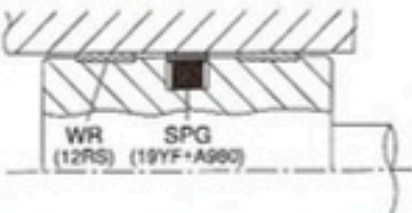
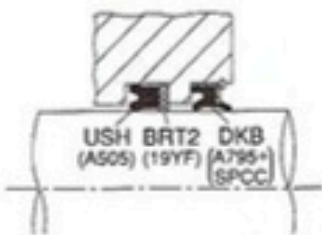
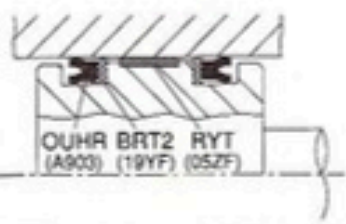
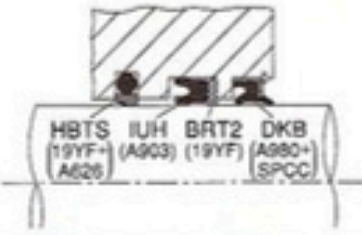
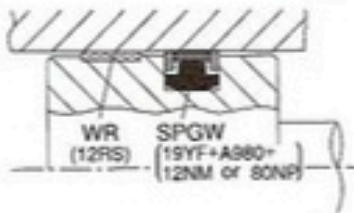

Application Examples by Equipment

Piston sealing system	Feature	Rod sealing system	Feature
 <p style="text-align: center;">SPGI (U841+A980)</p>	Compact SPGI assures easy assembly and high sealing ability.	 <p style="text-align: center;">USI (U503) DKBI (U801+SPCC)</p>	The combination of USI and DKBI is used to realize compact sealing system.
 <p style="text-align: center;">OUHR (A903) BRT2 (19YF) WR (12RS)</p>	OUHR is used because maintaining oil film is important for such single acting cylinder.	 <p style="text-align: center;">IUH (A903) DKBY (A980+SPCC)</p>	IUH is used in combination with DKBY because of the fluid filling type single acting cylinder. Dust seals are specially designed DKBY.
 <p style="text-align: center;">WR (12RS) SPG (19YF+A980)</p>	SPG is usable for operating condition requiring extremely short strokes.	 <p style="text-align: center;">HBTS (19YF+A526) ISI (U801) DWI (U801+SPCC)</p>	HBTS is used for buffer ring because this system is used in sealed condition. DWI with high dust proof characteristics is used for dust seals.
 <p style="text-align: center;">WR (12RS) SPG (19YF+A980)</p>	SPG with high durability is used. Two WR are used to prevent scoring between the piston head and the cylinder tube that can be caused by high lateral load typical for such operating condition.	 <p style="text-align: center;">IUH (A505) BRT2 (19YF) DKB (A795+SPCC)</p>	Packing and dust seal of nitrile rubber are used.
 <p style="text-align: center;">USH (A505) WR (12RS)</p>	Packings of nitrile rubber are used.	 <p style="text-align: center;">ISI (U801) DKI (U801+SPCC)</p>	DKI with high dust proof characteristics is used for dust seals.
 <p style="text-align: center;">USH (A505) WR (12RS)</p>	Because of less severe operating condition, O rings are mostly used, but USH packings are recommended to improve durability.	—	—
 <p style="text-align: center;">WR (12RS) SPGW (19YF+A980+12NM or 80NP)</p>	SPGW is used because of high impact pressure and for durability.	 <p style="text-align: center;">HBTS (19YF+A526) ISI (U841) BRT2 (19YF) DKBI (U801+SPCC)</p>	HBTS is used for buffer ring to reduce high impact pressure. Please add a drain to improve durability.

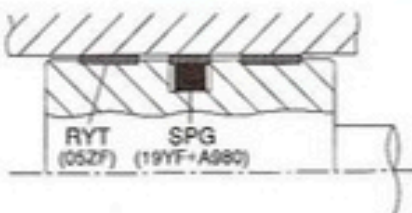
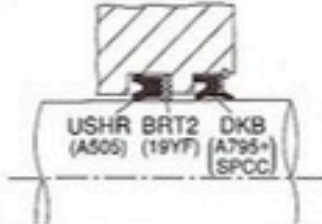
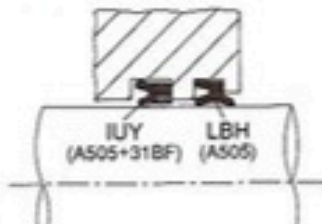
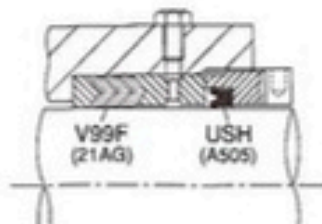
Equipment	Application	Operating condition
 <p>Robot</p>	—	0~20.6MPa (0~210kgf/cm ²) -10~80℃
 <p>Lift</p>	—	0~20.6MPa (0~210kgf/cm ²) -30~80℃
 <p>Injection molding machine</p>	—	0~31.4MPa (0~320kgf/cm ²) -10~100℃
 <p>Multi stories parking</p>	—	0~13.7MPa (0~140kgf/cm ²) -30~100℃
 <p>Hydraulic elevator</p>	—	0~4.9MPa (0~50kgf/cm ²) -20~80℃
 <p>Plunger pump</p>	—	0~13.7MPa (0~140kgf/cm ²) -10~80℃





Application Examples by Equipment

Piston sealing system	Feature	Rod sealing system	Feature
 <p style="text-align: center;">WR (12RS) SPG (19YF+A980)</p>	<p>High durability SPG is used. Two WR are used to prevent scoring between the piston head and the cylinder tube that can be caused by high lateral load typical for such operating condition.</p>	 <p style="text-align: center;">USH BRT2 DKB (A505) (19YF) (A795+SPCC)</p>	<p>Packing and dust seal of nitrile rubber are used.</p>
 <p style="text-align: center;">OUHR BRT2 RYT (A903) (19YF) (05ZF)</p>	<p>OUHR with stick slip proof characteristics is used considering the operating condition that requires to keep working pressure for a long time. 05ZF having small friction resistance is used for the material of wear ring.</p>	 <p style="text-align: center;">HBTS IUH BRT2 DKB (19YF+A626) (A903) (19YF) (A980+SPCC)</p>	<p>HBTS is used to prevent stick slip.</p>
 <p style="text-align: center;">WR (12RS) SPGW (19YF+A980+12NM or 80NF)</p>	<p>SPGW is used since such operating conditions mainly performed under high pressure require the durability. This packing has also excellent durability for the operations requiring extremely short strokes.</p>	 <p style="text-align: center;">HBTS ISI BRT2 DKB (19YF+A626) (U641) (19YF) (U801+SPCC)</p>	<p>HBTS is used for buffer ring to reduce high impact pressure. Please add a drain to improve durability.</p>
 <p style="text-align: center;">RYT (05ZF) SPG (19YF+A980)</p>	<p>High durability SPG is used. 05ZF having small friction resistance is used for the material of wear ring.</p>	 <p style="text-align: center;">USHR BRT2 DKB (A505) (19YF) (A795+SPCC)</p>	<p>USHR is used for packing to prevent stick slip. DKB is used for dust seal to prevent the oil scraping off.</p>
<p style="text-align: center;">—</p>	<p style="text-align: center;">—</p>	 <p style="text-align: center;">IUY LBH (A505+31BF) (A505)</p>	<p>IUY (of special shape) is used for packing to prevent stick slip. Rarefion is molded on to the IUY lip.</p>
<p style="text-align: center;">—</p>	<p style="text-align: center;">—</p>	 <p style="text-align: center;">V99F USH (21AG) (A505)</p>	<p>Fabric reinforced rubber V packings are used because in such operating conditions, fluids with poor lubricity, such as water and agricultural chemicals are handled and the frequency of operation is high. When pressure and frequency of operation are low, rubber V packings can be used.</p>

Equipment	Application	Operating condition
 <p data-bbox="304 707 519 741">Hydraulic breaker</p>	—	<p data-bbox="1292 286 1470 349">0~16.7MPa (0~170kgf/cm²)</p> <p data-bbox="1292 376 1436 409">-30~100℃</p>
 <p data-bbox="304 707 519 741">Hydraulic breaker</p>	—	<p data-bbox="1292 562 1470 624">0~17.7MPa (0~180kgf/cm²)</p> <p data-bbox="1292 651 1436 685">-30~100℃</p>
 <p data-bbox="315 965 498 999">Operation valve</p>	—	<p data-bbox="1292 837 1448 900">0~0.3MPa (0~3kgf/cm²)</p> <p data-bbox="1292 927 1436 960">-30~100℃</p>
 <p data-bbox="319 1245 498 1279">Power steering</p>	—	<p data-bbox="1292 1111 1459 1173">0~8.3MPa (0~85kgf/cm²)</p> <p data-bbox="1292 1200 1436 1234">-30~100℃</p>

Magnified view of sealing system	Feature
<p style="text-align: center;">ISI (U801) ISI (U801)</p>	<p>ISI are used in parallel because of high speed and high pressure. Noxlan is used for rubber material because of severe operating conditions.</p>
<p style="text-align: center;">XRI (U563) HBX (U641+80NP) HBTS (39YF+A627) HBX (U641+80NP) ISI (U801) DSI (U801)</p>	<p>HBX is used for upper hydraulic seals to reduce the friction. HBTS is also used to absorb impact pressure and reduce the friction. XRI with high wear resistance characteristics is used for gas seals to prevent oil scraping off from the gas chamber.</p>
<p style="text-align: center;">SVY (A216+31BF+SPCC+SWP)</p>	<p>SVY is used for low friction and high lip followability to eccentricity. This packing is fat metal case type with dust lip for easy seal replacement.</p>
<p style="text-align: center;">SPGO (19YF+A305) SCJY (A297+60NP+SPCC+SWP)</p>	<p>Low friction SPGO is used for the piston rings to improve system response. O ring is used for back ring to make compact the piston unit. For rod seals, oil seal SCJY with backup ring for high pressure operation is used. This seal has low friction resistance and high sealing ability.</p>

E

Equipment	Application	Operating condition
 <p>Construction equipment</p>	<p>Center spindle (center joint)</p>	<p>0~34.3MPa (0~350kgf/cm²) -30~100℃</p>
 <p>Construction equipment</p>	<p>Link pin Hinge pin</p>	<p>— -30~100℃</p>
 <p>Construction equipment</p>	<p>Crawler belt pin</p>	<p>— -30~80℃</p>
 <p>Industrial equipment</p>	<p>Pump Motor Reduction unit</p>	<p>-0.03~0.2MPa (-0.3~2kgf/cm²) -15~110℃</p>

E

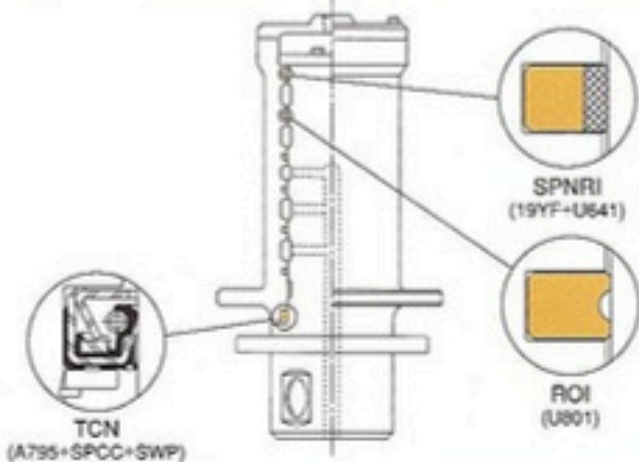
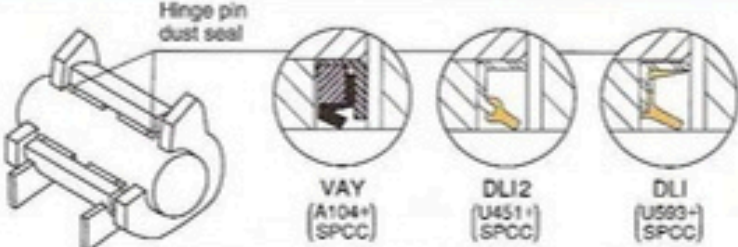
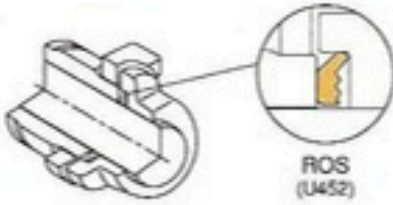
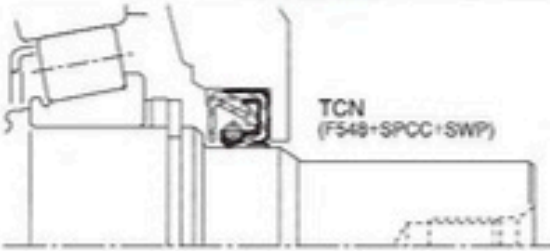
Magnified view of sealing system	Feature
 <p>TCN (A795+SPCC+SWP)</p> <p>SPNRI (19YF+U641)</p> <p>ROI (U801)</p>	<p>Seal fitting groove is mainly provided on the rotor side. ROI or SPNRI is used for each oil port seals. These packings have high durability and sealing ability. For the seal of drain port, oil seal (TCN) for high pressure is mainly used. This seal is used also as dust seal.</p>
 <p>Hinge pin dust seal</p> <p>VAY (A104+ SPCC)</p> <p>DLI2 (U451+ SPCC)</p> <p>DLI (U583+ SPCC)</p>	<p>VAY or DLI2, DLI is used to protect the bearings from dust. Grease draining mechanism should be provided for periodical grease replacement.</p>
 <p>ROS (U452)</p>	<p>ROC is used for this oscillating application, in order to retain lubricant oil and prevent entry of dust. There are two (2) types of structure, grease-filled type and oil-filled type.</p>
 <p>TCN (F548+SPCC+SWP)</p>	<p>TCN is used for high pressure application.</p>

SPECIAL PACKINGS FOR PISTON SEALS

ODI	F-3
OSI	F-11
OUIS	F-14
OUHR	F-16
SPG	F-19
SPGW	F-23
SPGO	F-27
SPGC	F-31
SPGI	F-35
CPI	F-37
CPH	F-39

SPECIAL PACKINGS FOR ROD SEALS

IDI	F-41
ISI	F-49
IUH	F-52
UNI	F-54
SPNO	F-57
SPN	F-60
SPNC	F-63

PACKINGS FOR BOTH PISTON AND ROD SEALS

UPI	F-67
USI	F-73
UPH	F-77
USH	F-85
V99F	F-89
V96H	F-95

DUST SEALS FOR RECIPROCAL MOVEMENT

DKI	F-101
DWI	F-104
DWIR	F-106
DKBI	F-108
DKB	F-110
DKH	F-113
DSI	F-116
LBI	F-119
LBH	F-121

BUFFER RINGS FOR RECIPROCAL MOVEMENT

HBY	F-125
HBTS	F-127

RELATING PRODUCTS FOR HYDRAULIC EQUIPMENT

RYT	F-129
WR	F-131
KZT	F-135
BRT2,3	F-138
BRN2,3	F-138

DUST SEALS FOR OSCILLATING AND ROTATING MOVEMENT

DLI2	F-142
DLI	F-144

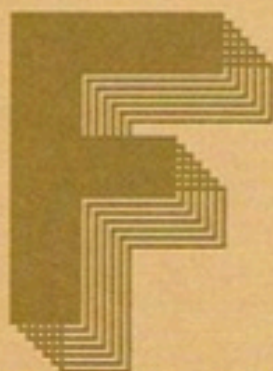

DIMENSION TABLE FOR NOK PACKINGS

About ordering NOK packing

Please place your order with the nearest NOK branch, sales office, or agent for NOK packing.

- 1** Please designate the NOK part number, type and size with your order. (Specifying methods are described in each dimension table.)
- 2** If you require packings that are not listed in the dimension tables, or have any difficulty selecting packings because of special operating condition, consult with NOK branch, sales office, or agent.
- 3** If you require type and size that are not listed in the dimension tables or material (rubber, plastic or metal case) other than standard materials for each type, new molding tool may be necessary.
- 4** Please inquire about availability and price at your nearest NOK branch, sales office, or agent.

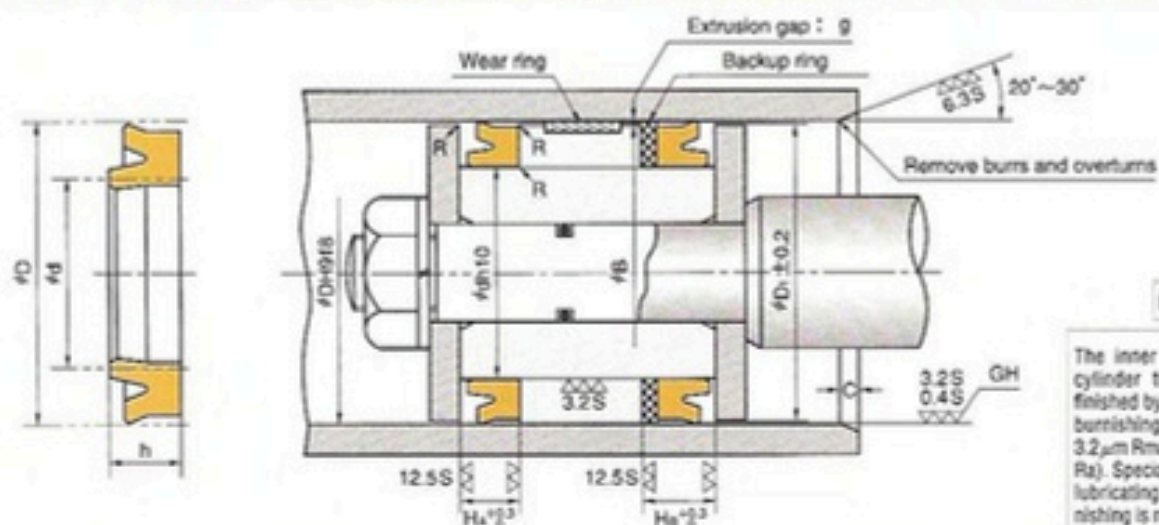

Nominal Size of Packing			Housing dimensions					C	NOK Part Number
D	d	h	ϕD	ϕd	ϕD_1	H_A	H_B		
18	8	7.5	18	8	17	8.5	10.5	2.5	FU2150H0
19.2	11.2	5	19.2	11.2	18.2	5.7	7.7		※FU0202H0
20	10	6	20	10	19	7	9		※FU0205H0
	10	7.5	20	10	19	8.5	10.5		FU0206H0
	10	8	20	10	19	9	11		FU0207H0
22	12	5	20	12	19	5.7	7.7	※FU0208H0	
	14	5	22	14	21	5.7	7.7	※FU0242H0	
24	14	7.5	24	14	23	8.5	10.5	3.5	FU2151H0
25	15	6	25	15	24	7	9		※FU0273H0
	15	8	25	15	24	9	11		FU0274H0
	17	5	25	17	24	5.7	7.7		※FU0275H0
26	16	7.5	26	16	25	8.5	10.5		FU2152H0
	18	5	26	18	25	5.7	7.7	※FU0310H0	
28	15	10	28	15	27	11	13	FU2153H0	
	20	5	28	20	27	5.7	7.7	※FU2138H0	
30	20	5	30	20	29	5.7	7.7	3.5	※FU0351H0
	20	6	30	20	29	7	9		※FU0352H0
	20	8	30	20	29	9	11	FU0353H0	
	22.4	5	30	22.4	29	5.7	7.7	2	※FU2139H0
31	18	10	31	18	30	11	13	3.5	FU2154H0
31.5	18.5	8	31.5	18.5	30.5	9	11		FU0377H0
	18.5	10	31.5	18.5	30.5	11	13		FU0378H0
	21.5	6	31.5	21.5	30.5	7	9		※FU0379H0
33	21.5	8	31.5	21.5	30.5	9	11		FU0380H0
	23.5	5	31.5	23.5	30.5	5.7	7.7		2
	20	10	33	20	32	11	13	3.5	FU2155H0
35	25	5	33	25	32	5.7	7.7	2	※FU2140H0
	22	10	35	22	34	11	13	3.5	FU2156H0
	25	6	35	25	34	7	9		※FU0418H0
25	8	35	25	34	9	11	FU0419H0		
35.4	22.4	10	35.4	22.4	34.4	11	13	FU2157H0	
35.5	22.5	8	35.5	22.5	34.5	9	11	3.5	FU0446H0
	22.5	10	35.5	22.5	34.5	11	13		FU0447H0
	25.5	6	35.5	25.5	34.5	7	9		※FU0448H0
	25.5	8	35.5	25.5	34.5	9	11		FU0449H0
38	25	10	38	25	37	11	13	3.5	FU0466H0
40	25	9	40	25	39	10	12		FU0485H0
	25	10	40	25	39	11	13		FU0486H0
	27	8	40	27	39	9	12		FU0488H0
41	27	10	40	27	39	11	14		FU0489H0
	30	8	40	30	39	9	12		FU0491H0
41	28	10	41	28	40	11	14		FU2158H0
43	30	10	43	30	42	11	14	FU2159H0	

The dimensions and pressure limit with ※ should be the same as OGI TYPE.

HOW TO DETERMINE B DIMENSION

■ When using backup ring

Please determine B dimension according to the table below. If you require smaller B dimension because of the cylinder configuration, please consult NOK.

Maximum Service Pressure	14MPa	21MPa	35MPa
Material of Backup ring	19YF		
B Dimension	$B \geq \phi D - 1.0$	$B \geq \phi D - 0.5$	$B \geq \phi D - 0.2$
Maximum Service Pressure	35MPa	42MPa	70MPa
Material of Backup ring	80NP		
B Dimension	$B \geq \phi D - 0.8$	$B \geq \phi D - 0.4$	$B \geq \phi D - 0.2$

■ When not using backup ring

To determine ϕB dimension, please refer to the graph in the right for the maximum extrusion gap (also refer page 26) considering the eccentricity of operating condition.

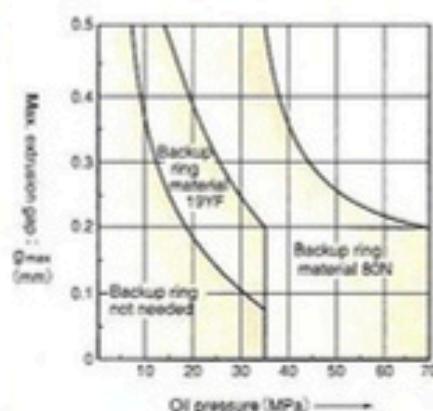

Nominal Size of Packing			Housing dimensions					C	NOK Part Number
D	d	h	ϕD	ϕd	ϕD_1	H_1	H_2		
44.5	31.5	10	44.5	31.5	43.5	11	14	3.5	FU2160H0
45	30	9	45	30	44	10	13		FU0559H0
	30	10	45	30	44	11	14		FU0560H0
	32	8	45	32	44	9	12		FU0561H0
	32	10	45	32	44	11	14		FU0562H0
50	35	8	45	35	44	9	12		FU0564H0
	34	10	50	34	49	11	14	FU0608H0	
	34	12	50	34	49	13	16	FU0609H0	
	35	9	50	35	49	10	13	FU0610H0	
	35	10	50	35	49	11	14	FU0611H0	
	35	12	50	35	49	13	16	FU2161H0	
51.5	35.5	12	51.5	35.5	50.5	13	16	FU0614H0	FU2162H0
55	40	9	55	40	54	10	13	FU0689H0	
	40	10	55	40	54	11	14	FU0690H0	
	45	8	55	45	54	9	12	FU0693H0	
56	40	10	56	40	55	11	14	FU0716H0	
	40	12	56	40	55	13	16	FU0717H0	
	41	9	56	41	55	10	13	FU0718H0	
	41	10	56	41	55	11	14	FU0719H0	
	46	8	56	46	55	9	12	FU0721H0	
60	45	9	60	45	59	10	13	FU0740H0	
	45	10	60	45	59	11	14	FU0741H0	
	50	8	60	50	59	9	12	FU0743H0	
61	45	12	61	45	60	13	16	FU2163H0	
63	47	10	63	47	62	11	14	FU0779H0	
	47	12	63	47	62	13	16	FU0780H0	
	48	9	63	48	62	10	13	FU0781H0	
	48	10	63	48	62	11	14	FU0782H0	
	53	8	63	53	62	9	12	FU0785H0	
65	50	9	65	50	64	10	13	FU0804H0	
	50	10	65	50	64	11	14	FU0805H0	
	55	8	65	55	64	9	12	FU0808H0	
66	50	12	66	50	65	13	16	FU2164H0	
69	53	12	69	53	68	13	16	FU0836H0	
70	50	12	70	50	69	13	16	FU0842H0	
	55	9	70	55	69	10	13	FU0844H0	
	55	10	70	55	69	11	14	FU0845H0	
	60	8	70	60	69	9	12	FU0847H0	

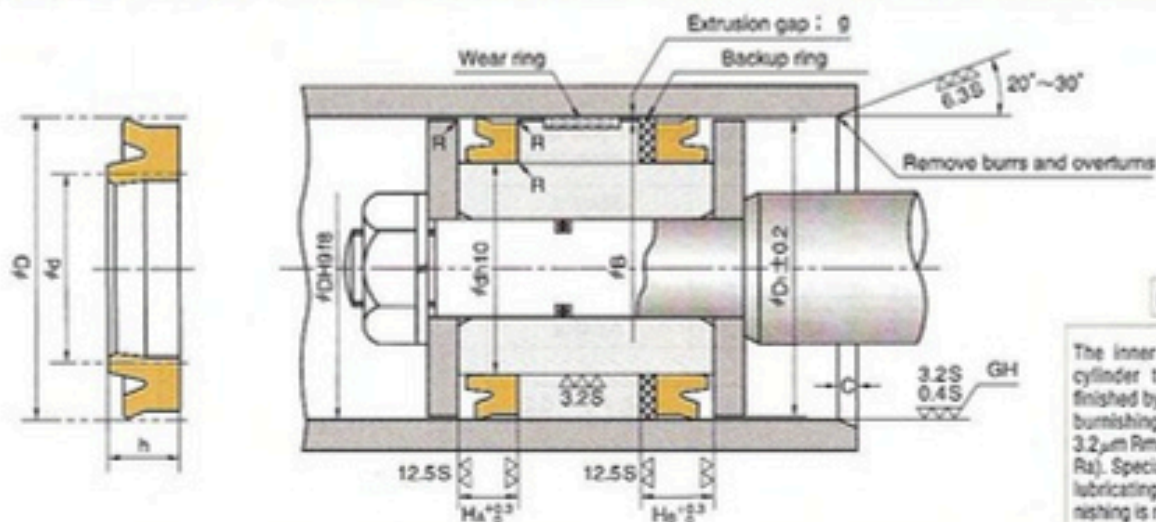

Nominal Size of Packing			Housing dimensions					C	NOK Part Number
D	d	h	#D	#d	#D ₁	H _k	H _e		
71	51	12	71	51	70	13	16	5	FU0872H0
	55	10	71	55	70	11	14		FU0873H0
	55	12	71	55	70	13	16		FU0874H0
	56	9	71	56	70	10	13		FU0875H0
	56	10	71	56	70	11	14		FU0876H0
	61	8	71	61	70	9	12		FU0878H0
75	55	12	75	55	74	13	16		FU0894H0
	60	9	75	60	74	10	13		FU0895H0
	60	10	75	60	74	11	14		FU0896H0
	65	8	75	65	74	9	12		FU0898H0
76	80	12	76	80	75	13	16		FU2165H0
80	60	12	80	60	79	13	16		FU0929H0
	64	10	80	64	79	11	14		FU0931H0
	64	12	80	64	79	13	16		FU0932H0
	65	9	80	65	79	10	13		FU0933H0
	65	10	80	65	79	11	14		FU0934H0
	70	8	80	70	79	9	12		FU0937H0
85	65	12	85	65	84	13	16		FU0974H0
	70	9	85	70	84	10	13	FU0977H0	
	70	10	85	70	84	11	14	FU0978H0	
	75	8	85	75	84	9	12	FU0980H0	
90	70	12	90	70	89	13	16	FU1014H0	
	70	15	90	70	89	16	19	FU1015H0	
	75	9	90	75	89	10	13	FU1017H0	
	75	10	90	75	89	11	14	FU1018H0	
	80	8	90	80	89	9	12	FU1020H0	
95	75	12	95	75	94	13	16	FU1045H0	
	75	15	95	75	94	16	19	FU1046H0	
	80	9	95	80	94	10	13	FU1047H0	
	80	10	95	80	94	11	14	FU1048H0	
100	80	12	100	80	98	13	16	FU1072H0	
	80	15	100	80	98	16	19	FU1074H0	
	85	10	100	85	98	11	14	FU1079H0	
105	85	15	105	85	103	16	19	FU2166H0	
110	90	12	110	90	108	13	16	FU1149H0	
	90	15	110	90	108	16	19	FU1150H0	
	95	10	110	95	108	11	14	FU1153H0	
112	92	12	112	92	110	13	16	FU1174H0	
	92	15	112	92	110	16	19	FU1175H0	
	97	9	112	97	110	10	13	FU1176H0	
	97	10	112	97	110	11	14	FU1177H0	

HOW TO DETERMINE B DIMENSION

■ When using backup ring

Please determine B dimension according to the table below. If you require smaller B dimension because of the cylinder configuration, please consult NOK.

Maximum Service Pressure	14MPa	21MPa	35MPa
Material of Backup ring	19YF		
B Dimension	$B \geq \phi D - 1.0$	$B \geq \phi D - 0.5$	$B \geq \phi D - 0.2$
Maximum Service Pressure	35MPa	42MPa	70MPa
Material of Backup ring	80NP		
B Dimension	$B \geq \phi D - 0.8$	$B \geq \phi D - 0.4$	$B \geq \phi D - 0.2$

■ When not using backup ring

To determine ϕB dimension, please refer to the graph in the right for the maximum extrusion gap (also refer page 26) considering the eccentricity of operating condition.

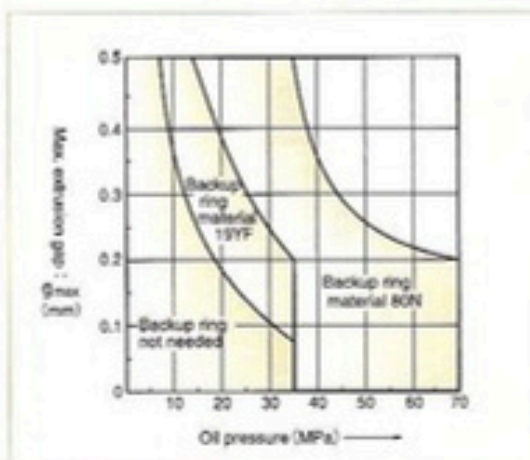

Nominal Size of Packing			Housing dimensions					C	NOK Part Number	
D	d	h	ϕD	ϕd	ϕD_1	H_A	H_B			
115	95	15	115	95	113	16	19	5	FU2167H0	
		120	12	120	100	118	13		16	FU1210H0
			15	120	100	118	16		19	FU1211H0
120	100	10	120	105	118	11	14		FU1213H0	
		125	12	125	105	123	13		16	FU1243H0
			15	125	105	123	16		19	FU1244H0
			16	125	105	123	17		20	FU1245H0
			110	9	125	110	123		10	13
110	10	125	110	123	11	14	FU1248H0			
130	110	12	130	110	128	13	16		FU1274H0	
		15	130	110	128	16	19		FU1275H0	
		16	130	110	128	17	20		FU1276H0	
		115	10	130	115	128	11		14	FU1279H0
		132	112	15	132	112	130		16	19
140	12			140	120	138	13		16	FU1316H0
	15			140	120	138	16	19	FU1317H0	
	16	140	120	138	17	20	FU1318H0			
150	125	10	140	125	138	11	14	FU1321H0		
		19	150	125	148	20	23	FU2169H0		
		20	150	125	148	21	24	FU1351H0		
		130	12	150	130	148	13	16	FU1352H0	
			16	150	130	148	17	20	FU1354H0	
157	132	20	157	132	155	11	14	FU1357H0		
		24	157	132	155	21	24	FU1909H0		
		160	19	160	135	158	20	23	FU2170H0	
			20	160	135	158	21	24	FU1398H0	
			12	160	140	158	13	16	FU1399H0	
165	140	16	160	140	158	17	20	FU1402H0		
		10	160	145	158	11	14	FU1405H0		
		19	165	140	163	20	23	FU1426H0		
		20	165	140	163	21	24	FU2186H0		
		170	145	19	170	145	168	20	23	FU1436H0
20	170			145	168	21	24	FU1437H0		
12	170			150	168	13	16	FU1438H0		
16	170			150	168	17	20	FU1440H0		
10	170			155	168	11	15	FU1442H0		
180	155	16	180	155	178	17	21	FU1475H0		
		19	180	155	178	20	24	FU2171H0		
		20	180	155	178	21	25	FU1476H0		
		12	180	160	178	13	17	FU1478H0		
		16	180	160	178	17	21	FU1479H0		
		10	180	165	178	11	15	FU1482H0		

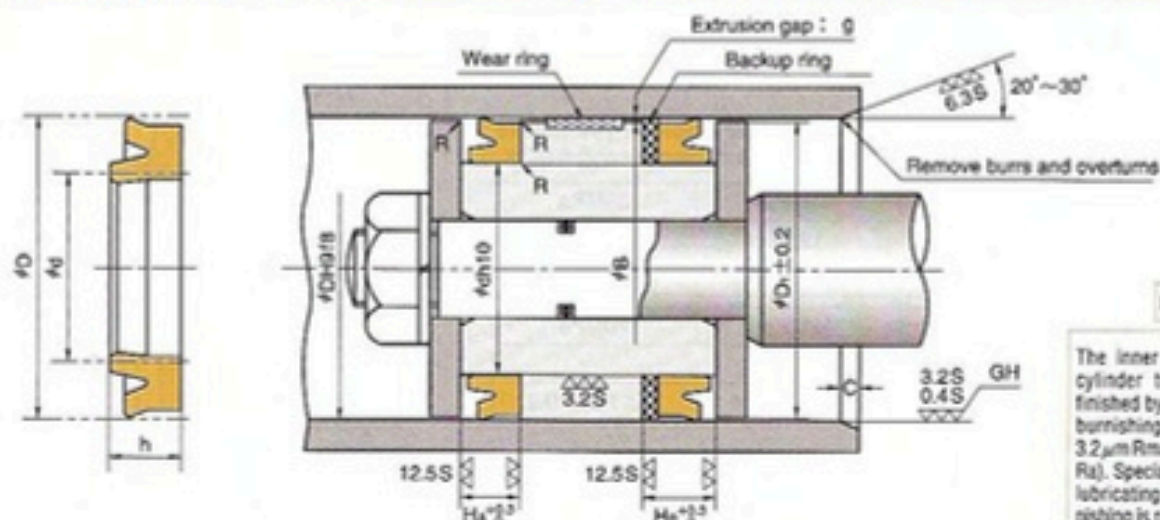

Ra0.3 or below

The inner surface of the cylinder tube should be finished by honing (GH) or burnishing (RLB) to 0.4 to 3.2 μm Rmax (0.1 to 0.8 μm Ra). Specially under severe lubricating condition, burnishing is required.

Nominal Size of Packing			Housing dimensions						C	NOK Part Number
D	d	h	ϕD	ϕd	ϕD_1	H_A	H_B			
185	160	19	185	160	183	20	24	6.5	FU2172H0	
	160	20	185	160	183	21	25		FU2187H0	
190	165	16	190	165	188	17	21		FU1507H0	
	165	20	190	165	188	21	25		FU1508H0	
	170	12	190	170	188	13	17		FU1509H0	
	170	16	190	170	188	17	21		FU1510H0	
	175	10	190	175	188	11	15		FU1512H0	
200	175	16	200	175	198	17	21		FU1536H0	
	175	19	200	175	198	20	24		FU2173H0	
	175	20	200	175	198	21	25		FU1538H0	
	180	16	200	180	198	17	21		FU1540H0	
205	180	19	205	180	203	20	24		FU2174H0	
	180	20	205	180	203	21	25		FU2188H0	
210	185	16	210	185	208	17	21		FU1570H0	
	185	20	210	185	208	21	25		FU1571H0	
	190	16	210	190	208	17	21		FU1573H0	
215	190	16	215	190	213	17	21		FU2260H0	
220	195	16	220	195	218	17	21		FU1592H0	
	195	20	220	195	218	21	25		FU1593H0	
	200	16	220	200	218	17	21		FU1595H0	
224	199	16	224	199	222	17	21	FU1604H0		
	199	20	224	199	222	21	25	FU1605H0		
	204	16	224	204	222	17	21	FU1607H0		
225	200	16	225	200	223	17	21	FU1616H0		
	200	19	225	200	223	20	24	FU2175H0		
	200	20	225	200	223	21	25	FU1617H0		
	205	16	225	205	223	17	21	FU1619H0		
	205	16	225	205	223	17	21	FU1632H0		
230	205	19	230	205	228	20	24	FU1633H0		
	205	20	230	205	228	21	25	FU1634H0		
	210	16	230	210	228	17	21	FU1636H0		
	215	16	240	215	238	17	21	FU1652H0		
240	215	19	240	215	238	20	24	FU1653H0		
	215	20	240	215	238	21	25	FU1654H0		
	220	16	240	220	238	17	21	FU1656H0		
	225	16	250	225	248	17	21	FU1671H0		
250	225	19	250	225	248	20	24	FU1672H0		
	225	20	250	225	248	21	25	FU1673H0		
	230	16	250	230	248	17	21	FU1676H0		
	235	16	260	235	258	17	21	FU1698H0		
260	235	19	260	235	258	20	24	FU1699H0		
	240	16	260	240	258	17	21	FU1701H0		

HOW TO DETERMINE B DIMENSION

■ When using backup ring

Please determine B dimension according to the table below. If you require smaller B dimension because of the cylinder configuration, please consult NOK.

Maximum Service Pressure	14MPa	21MPa	35MPa
Material of Backup ring	19YF		
B Dimension	$B \geq \phi D - 1.0$	$B \geq \phi D - 0.5$	$B \geq \phi D - 0.2$
Maximum Service Pressure	35MPa	42MPa	70MPa
Material of Backup ring	80NP		
B Dimension	$B \geq \phi D - 0.8$	$B \geq \phi D - 0.4$	$B \geq \phi D - 0.2$

■ When not using backup ring

To determine ϕB dimension, please refer to the graph in the right for the maximum extrusion gap (also refer page 26) considering the eccentricity of operating condition.

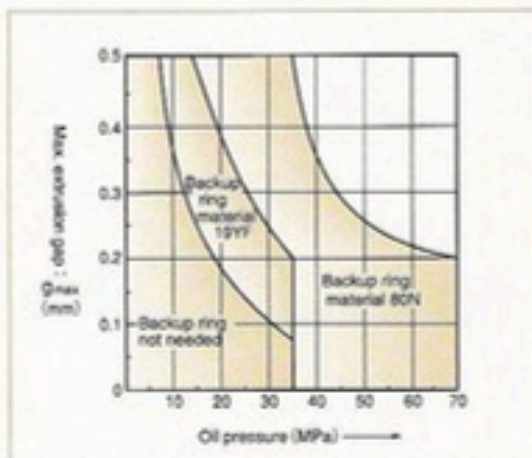

Nominal Size of Packing			Housing dimensions					C	NOK Part Number
D	d	h	ϕD	ϕd	ϕD_1	H_1	H_2		
270	245	16	270	245	268	17	21	6.5	FU1715H0
	245	19	270	245	268	20	24		FU1716H0
	250	16	270	250	268	17	21		FU1718H0
275	250	19	275	250	273	20	24	7.5	FU2176H0
	250	20	275	250	273	21	25		FU2189H0
280	250	19	280	250	278	20	24	7.5	FU1729H0
	255	19	280	255	278	20	24		FU1731H0
290	260	19	290	260	288	20	24	7.5	FU1744H0
	265	19	290	265	288	20	24		FU1746H0
297	265	24	297	265	295	25	29	7.5	FU2177H0
	265	25	297	265	295	26	30		FU2190H0
300	270	19	300	270	298	20	24	7.5	FU1758H0
	270	24	300	270	298	25	29		FU2178H0
	270	25	300	270	298	26	30		FU1759H0
	275	19	300	275	298	20	24		FU1761H0
312	280	24	312	280	310	25	29	7.5	FU2193H0
332	300	24	332	300	330	25	29		FU2194H0

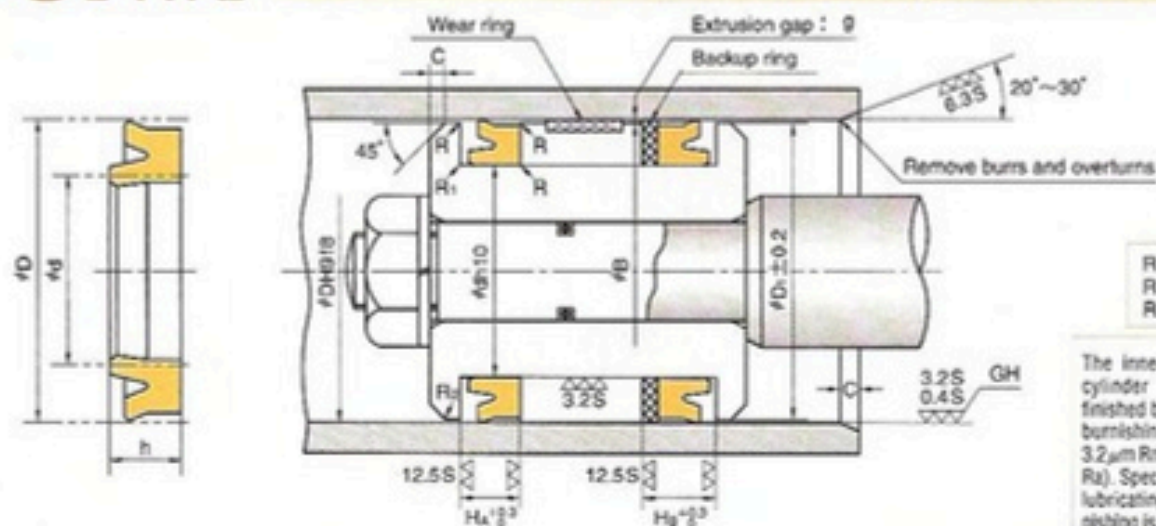

Nominal Size of Packing			Housing dimensions						NOK Part Number
D	d	h	#D	#d	#D ₁	H _k	H _b	C	
35	27	5	35	27	34	5.7	8.7	2	FU0420L0
35.5	27.5	5	35.5	27.5	34.5				FU0450L0
	28	5	35.5	28	34.5	FU2141L0			
40	30	6	40	30	39	7	10	2.5	FU0490L0
41.5	31.5	6	41.5	31.5	40.5				FU2142L0
	45	35	6	45	35	44	FU0563L0		
35.5		6	45	35.5	44	FU2143L0			
50	40	6	50	40	49	FU0613L0			
	45	6	55	45	54	FU0692L0			
56	45	7	56	45	55	8	11	FU2144L0	
	46	6	56	46	55	FU0720L0			
60	50	6	60	50	59	7	10	2.5	FU0742L0
63	53	6	63	53	62				FU0784L0
65	55	6	65	55	64	8	11	FU0807L0	
66	56	6	66	56	65			FU0825L0	
70	60	6	70	60	69	7	10	FU0846L0	
71	60	7	71	60	70			8	11
	61	6	71	61	70	FU0877L0			
73	63	6	73	63	72	7	10	2.5	FU0889L0
75	65	6	75	65	74				FU0897L0
77	67	6	77	67	76	7	10	FU0922L0	
80	70	6	80	70	79			FU0936L0	
	71	6	80	71	79	FU2148L0			
85	75	6	85	75	84	10	13	4	FU0979L0
90	80	6	90	80	89				FU1019L0
100	85	9	100	85	98	9.5	12.5	FU1078L0	
105	90	9	105	90	103			FU1120L0	
110	95	9	110	95	108	10	13	FU1152L0	
112	98	8.5	112	98	110			9.5	12.5
115	100	9	115	100	113	10	13	FU1193L0	
120	105	9	120	105	118			9.5	12.5
	106	8.5	120	106	118	FU2148L0			
125	112	9	125	112	123	10	13	FU1926L0	
130	115	9	130	115	128			FU1278L0	
140	125	9	140	125	138	9.5	12.5	FU1320L0	
150	135	9	150	135	148			FU1356L0	
	136	8.5	150	136	148	FU2149L0			

HOW TO DETERMINE B DIMENSION

■ When using backup ring

Please determine B dimension according to the table below. If you require smaller B dimension because of the cylinder configuration, please consult NOK.

Maximum Service Pressure	14MPa	21MPa	35MPa
Material of Backup ring	19YF		
B Dimension	$B \geq \phi D - 1.0$	$B \geq \phi D - 0.5$	$B \geq \phi D - 0.2$

Maximum Service Pressure	35MPa	42MPa
Material of Backup ring	80NP	
B Dimension	$B \geq \phi D - 0.8$	$B \geq \phi D - 0.4$

■ When not using backup ring

To determine ϕB dimension, please refer to the graph in the right for the maximum extrusion gap (also refer page 26) considering the eccentricity of operating condition.

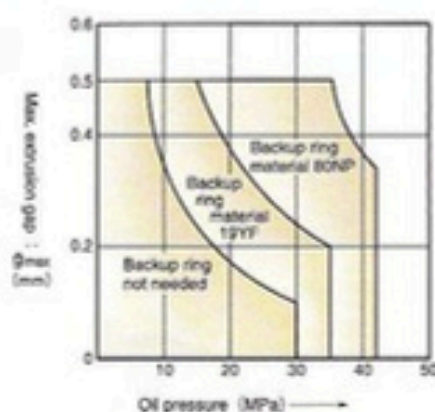

Nominal Size of			Housing dimensions						NOK
D	d	h	ϕD	ϕd	ϕD_1	H_A	H_B	C	Part Number
155	140	9	155	140	153	10	13	4	FU1386L0
160	145	9	160	145	158				FU1404L0
170	155	9	170	155	168		14		FU1441L0
175	160	9	175	160	173				FU1458L0
180	165	9	180	165	178				FU1481L0
190	175	9	190	175	188				FU1511L0
200	180	12	200	180	198	13	17	FU1539L0	
210	190	12	210	190	208			FU1572L0	
220	200	12	220	200	218			FU1594L0	
224	204	12	224	204	222			FU1606L0	
225	205	12	225	205	223			FU1618L0	
230	210	12	230	210	228			FU1635L0	
240	220	12	240	220	238			FU1655L0	
250	230	12	250	230	248			FU1675L0	
260	240	12	260	240	258			FU1700L0	
270	250	12	270	250	268			FU1717L0	
280	255	16	280	255	278	17	21	FU1730L0	
290	265	16	290	265	288			FU1745L0	
300	275	16	300	275	298			FU1760L0	

OUIS_{TYPE}

SPECIAL PACKINGS FOR PISTON SEALS
NOXLAN (AU)



F

- Please designate NOK Part number and type & size on your order.

(Example) • Type Dimensions OUIS 40 30 6

Type Sign

Nominal Size of Packing
described in order of outer diameter(D), inner diameter(d), and height(h)

• Part Number FU0490P0

- Please check the application range on pages D-2 and 3 before selecting the type.

Material	NOK U641
-----------------	----------

OUIS TYPE SPECIAL PACKINGS FOR PISTON SEALS (INSTALLED WITH INTERNAL GROOVE)

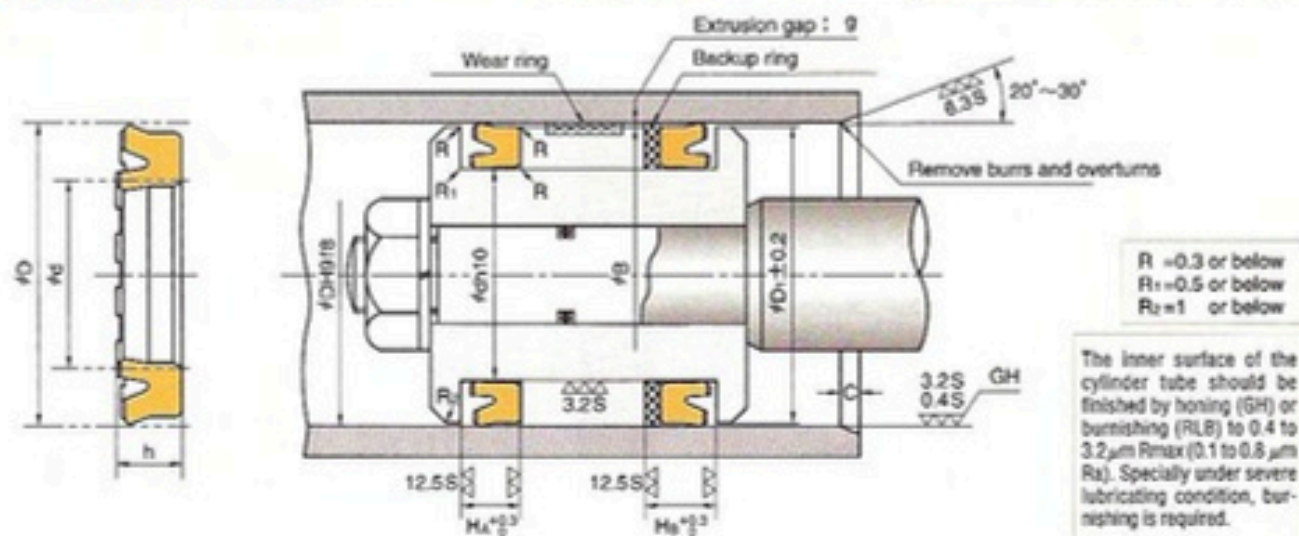

HOW TO DETERMINE B DIMENSION

■ When using backup ring

Please determine B dimension according to the table below. If you require smaller B dimension because of the cylinder configuration, please consult NOK.

Maximum Service Pressure	14MPa	21MPa	35MPa
Material of Backup ring	19YF		
B Dimension	$B \geq \phi D - 1.0$	$B \geq \phi D - 0.5$	$B \geq \phi D - 0.2$

Maximum Service Pressure	35MPa	42MPa
Material of Backup ring	80NP	
B Dimension	$B \geq \phi D - 0.8$	$B \geq \phi D - 0.4$

■ When not using backup ring

To determine ϕB dimension, please refer to the graph in the right for the maximum extrusion gap (also refer page 26) considering the eccentricity of operating condition.

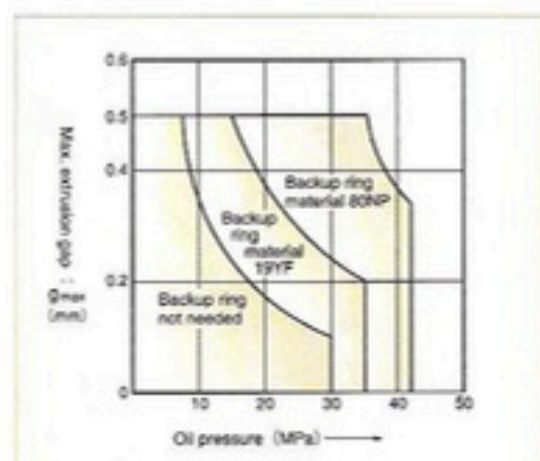

Nominal Size of Packing			Housing dimensions						NOK Part Number			
D	d	h	φD	φd	φD ₁	H _k	H _s	C				
40	30	6	40	30	39	7	10	2.5	FU0490P0			
45	35	6	45	35	44				FU0563P0			
50	40	6	50	40	49				FU0613P0			
60	50	6	60	50	59				FU0742P0			
63	53	6	63	53	62				FU0784P0			
65	55	6	65	55	64				FU0807P0			
70	60	6	70	60	69				FU0846P0			
75	65	6	75	65	74				FU0897P0			
80	70	6	80	70	79				FU0936P0			
85	75	6	85	75	84				FU0979P0			
90	80	6	90	80	89				FU1019P0			
100	85	9	100	85	98				10	13	4	FU1078P0
105	90	9	105	90	103							FU1120P0
110	95	9	110	95	108							FU1152P0
120	105	9	120	105	118	FU1212P0						
125	112	9	125	112	123	FU1926P0						
130	115	9	130	115	128	FU1278P0						
140	125	9	140	125	138	FU1320P0						
150	135	9	150	135	148	FU1356P0						
160	145	9	160	145	158	FU1404P0						
170	155	9	170	155	168	FU1441P0						
180	165	9	180	165	178	FU1481P0						
190	175	9	190	175	188	FU1511P0						
200	180	12	200	180	198	13	17	5	FU1539P0			

OUHR^{TYPE}

SPECIAL PACKINGS FOR PISTON SEAL
NITRILE RUBBER (NBR)



F

- Please designate NOK Part number and type & size on your order.

(Example) • Type Dimensions OUHR 40 30 6

Type Sign

Nominal Size of Packing
described in order of outer diameter(D), inner diameter(d), and height(h)

• Part Number CU2684Q0

- Please check the application range on pages D-2 and 3 before selecting the type.

Material	NOK A903
----------	----------

OUHR TYPE SPECIAL PACKINGS FOR PISTON SEALS (INSTALLED WITH INTERNAL GROOVE)

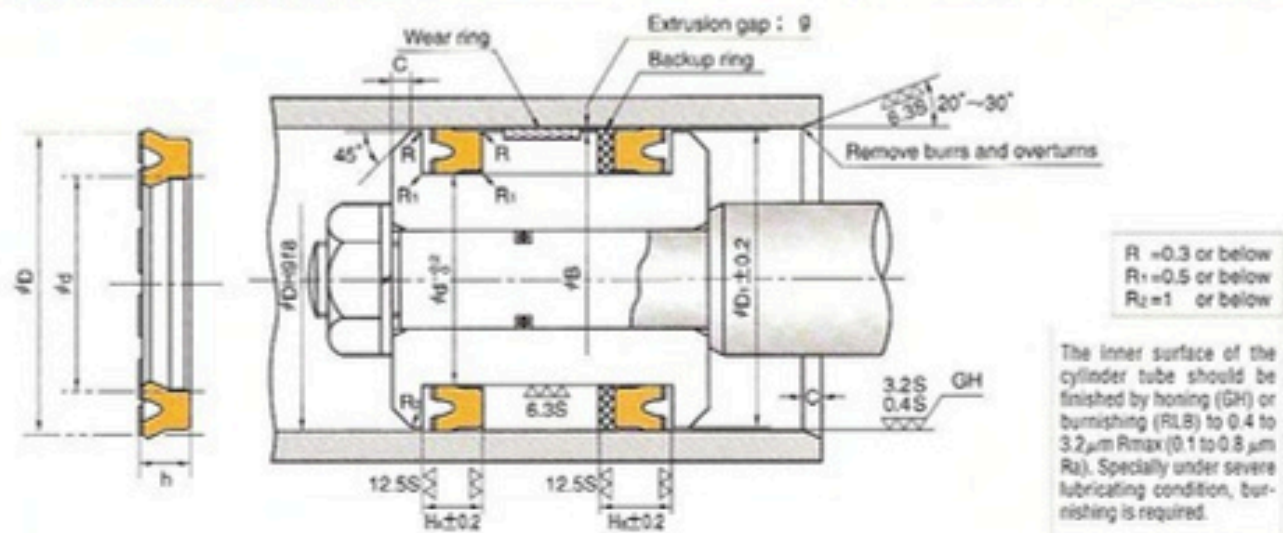

HOW TO DETERMINE B DIMENSION

■ When using backup ring

Please determine B dimension according to the table below. If you require smaller B dimension because of the cylinder configuration, please consult NOK.

Maximum Service Pressure	14MPa	21MPa
Material of Backup ring	19YF	
B Dimension	$B \geq \phi D - 1.0$	$B \geq \phi D - 0.5$

■ When not using backup ring

To determine ϕB dimension, please refer to the graph in the right for the maximum extrusion gap (also refer page 26) considering the eccentricity of operating condition.

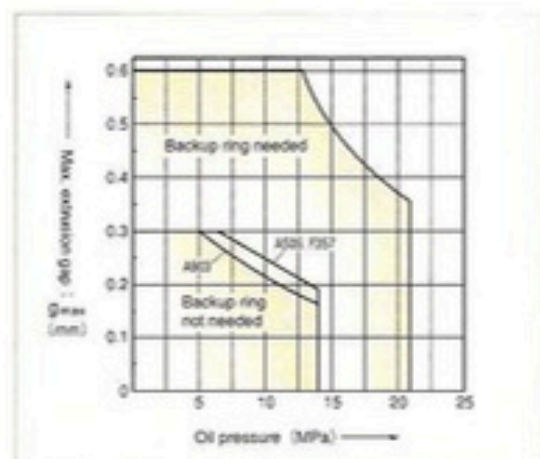

Nominal Size of Packing			Housing dimensions					NOK Part Number			
D	d	h	ϕD	ϕd	ϕD_1	H_k	H_b	C	Part Number		
40	30	6	40	30	39	7	10	3.5	CU2684Q0		
50	40	6	50	40	49				CU2604Q0		
60	50	6	60	50	59				CU2696Q0		
65	55	6	65	55	64				CU2930Q0		
75	62	7.5	75	62	74	8.5	11.5	4.5	CU2943Q0		
80	65	9	80	65	79				CU2666Q0		
85	70	9	85	70	84				CU0977Q0		
95	80	9	95	80	94				CU2605Q0		
100	85	9	100	85	98	10	13	4.5	CU2669Q0		
110	95	9	110	95	108				CU2607Q0		
130	115	8.5	130	115	128				9.5	12.5	CU2609Q0
140	125	9	140	125	138				10	13	CU2647Q0
200	180	12	200	180	198	13	17	5.5	CU1539Q0		

F

SPG_{TYPE}

SPECIAL PACKINGS FOR PISTON SEALS
RAREFLON(PTFE) + NITRILE RUBBER (NBR)



- Please designate NOK Part number and type & size on your order.

(Example) • Type Dimensions SPG 20.5 30 4.3

Type Sign

Nominal Size of Packing
described in order of inner diameter(d), outer diameter(D), and height(h)

• Part Number GS0327V0

- Please check the application range on pages D-2 and 3 before selecting the type.

Material	NOK 19YF + NOK A980 : Outer diameter 950mm or less NOK 19YF + NOK A402 : Outer diameter more than 950mm
-----------------	--

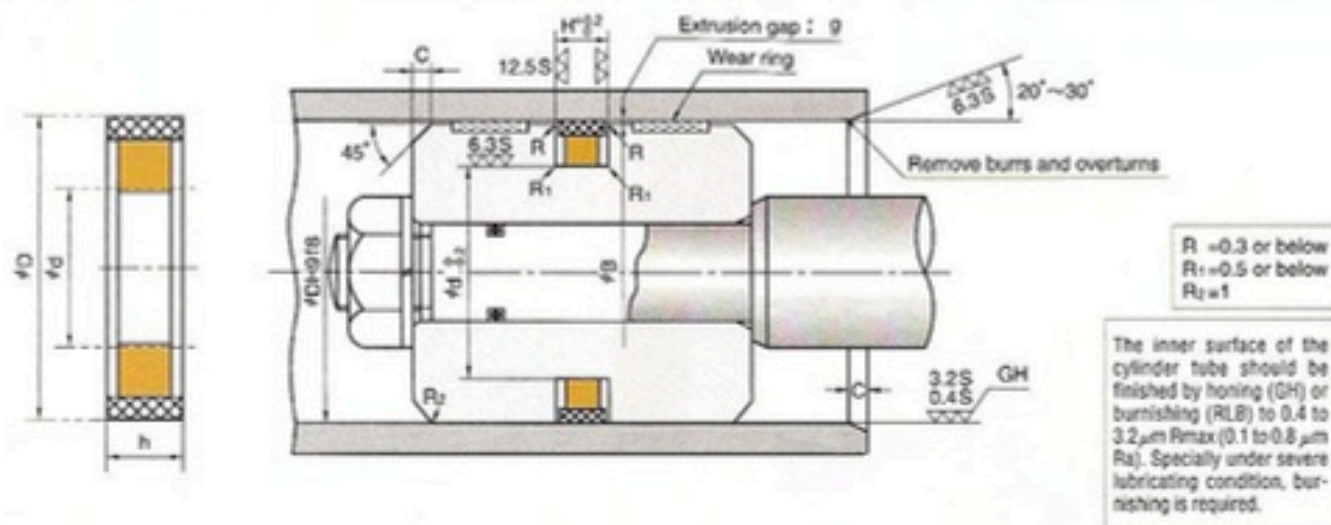

Nominal Number	Nominal Size of Packing			Housing dimensions				NOK Part Number
	d	D	h	ϕd	ϕD	H	C	
SPG 30	20.5	30	4.3	20.5	30	4.5	2	GS0327V0
31.5	22	31.5		22	31.5			GS0328V0
32	22.5	32		22.5	32			GS0329V0
35	25.5	35		25.5	35			GS0330V0
35.5	26	35.5		26	35.5			GS0331V0
40	30	40		30	40			GS0332V0
45	35	45		35	45			GS0333V0
50	40	50		40	50			GS0334V0
55	45	55		45	55			GS0335V0
56	46	56		46	56			GS0336V0
60	50	60	7.3	50	60	7.5	4	GS0337V0
63	48	63		48	63			GS0338V0
65	50	65		50	65			GS0339V0
69	54	69		54	69			GS0340V0
70	55	70		55	70			GS0341V0
71	56	71		56	71			GS0342V0
75	60	75		60	75			GS0343V0
80	65	80		65	80			GS0344V0
85	70	85		70	85			GS0345V0
90	75	90		75	90			GS0310V0
95	80	95		80	95			GS0346V0
100	85	100		85	100			GS0347V0
108	92	108	92	108	GS0348V0			
110	94	110	94	110	GS0311V0			
112	96	112	96	112	6.5	GS0349V0		

HOW TO DETERMINE B DIMENSION

To determine ϕB dimension, please refer to the graph in the right for the maximum extrusion gap (also refer page 26) considering the eccentricity of operating condition.

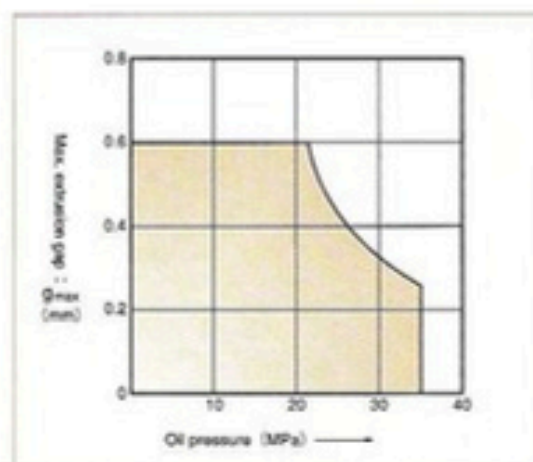

Nominal Number	Nominal Size of Packing			Housing dimensions				NOK Part Number
	d	D	h	ϕd	ϕD	H	C	
SPG 120	104	120	7.3	104	120	7.5	6.5	GS0350V0
125	109	125		109	125			GS0351V0
130	114	130		114	130			GS0352V0
140	124	140		124	140			GS0353V0
145	129	145		129	145			GS0885V0
150	134	150		134	150			GS0354V0
155	139	155		139	155			GS3133V0
160	144	160		144	160			GS0355V0
170	148	170		148	170			GS0356V0
180	158	180		158	180			GS0357V0
190	168	190	10.8	168	190	11	GS0358V0	
200	178	200		178	200		GS0359V0	
204	182	204		182	204		GS0360V0	
210	188	210		188	210		GS0361V0	
220	198	220		198	220		GS0842V0	
224	202	224		202	224		GS0362V0	
225	203	225		203	225		GS0363V0	
230	208	230		208	230		GS0364V0	
240	218	240		218	240		GS0365V0	
250	228	250		228	250		GS0366V0	
260	236	260	11.7	236	260	12	GS0700V0	
270	246	270		246	270		GS0701V0	
280	256	280		256	280		GS0702V0	
290	266	290		266	290		GS0703V0	
300	276	300		276	300		GS0704V0	
310	286	310		286	310		GS0705V0	
320	296	320		296	320		GS0706V0	

F

SPG TYPE SPECIAL PACKINGS FOR PISTON SEALS (LARGE DIMENSION)

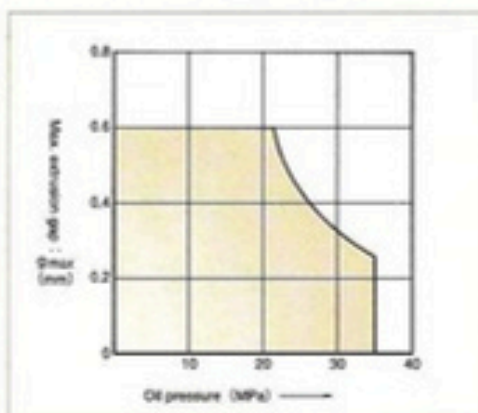
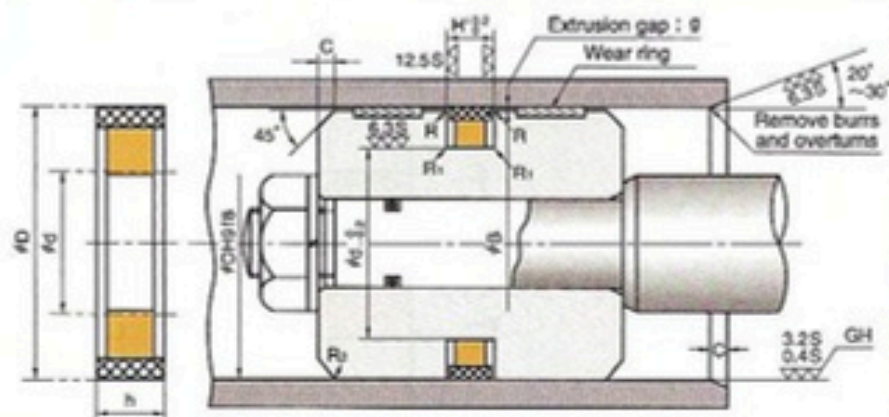

The inner surface of the cylinder tube should be finished by honing (GH) or burnishing (RLB) to 0.4 to 3.2 μm R_{max} (0.1 to 0.8 μm R_{a}). Specially under severe lubricating condition, burnishing is required.

$R = 0.3$ or below
 $R_1 = 0.5$ or below
 $R_2 = 1$

HOW TO DETERMINE B DIMENSION

To determine #B dimension, please refer to the graph in the right for the maximum extrusion gap (also refer page 25) considering the eccentricity of operating condition.

Nominal Number	Nominal Size of Packing			Housing dimensions				NOK Part Number
	d	D	h	#d	#D	H	C	
SPG 330	308	330	9.75	308	330	10	10	GS0408V0
360	336	360	11.7	336	360	12		GS0917V0
485	455	485	14.8	455	485	15		GS0504V1
500	470	500	14.8	470	500	15		GS0261V2
550	515	550	17.2	515	550	17.5		GS0379V2
600	570	600	14.8	570	600	15		GS0324V2
650	620	650	14.8	620	650	15		GS0527V0
720	690	720	14.8	690	720	15		GS0492V0
800	785	800	12.7	785	800	13		GS0520V0
900	870	900	24.5	870	900	25		GS0407V2
930	890	930	19	890	930	20	15	GS0466V1
935	920	935	12.7	920	935	13		GS0521V0
950	925	950	17.7	925	950	18		GS0285V2
1000	960	1000	19.7	960	1000	20		GS0512V0
1060	1020	1060	19.7	1020	1060	20		GS0587V0
1120	1080	1120	19.7	1080	1120	20		GS0584V0
1150	1110	1150	19.7	1110	1150	20		GS3007V0
1180	1130	1180	19.7	1130	1180	20		GS0599V1
1210	1170	1210	19	1170	1210	20		GS0465V0
1250	1210	1250	19.7	1210	1250	20		GS0281V0
1260	1220	1260	19.7	1220	1260	20	GS0851V0	
1400	1350	1400	19.7	1350	1400	20	GS0402V0	
1500	1460	1500	19.7	1460	1500	20	GS0852V0	
1650	1600	1650	24	1600	1650	25	20	GS0579V0

SPGW_{TYPE}

SPECIAL PACKINGS FOR PISTON SEALS
RAREFLON(PTFE) + POLYAMIDE RESIN + NITRILE RUBBER(NBR)



- Please designate NOK Part number and type & size on your order.

(Example) • Type Dimensions SPGW 36 50 8.5

Type Sign

Nominal Size of Packing
described in order of inner diameter(d), outer diameter(D), and height(h)

• Part Number GS0535V2

- Please check the application range on pages D-2 and 3 before selecting the type.

Material	NOK 19YF + NOK 80NP + NOK A980
-----------------	--------------------------------

SPGW TYPE SPECIAL PACKINGS FOR PISTON SEALS

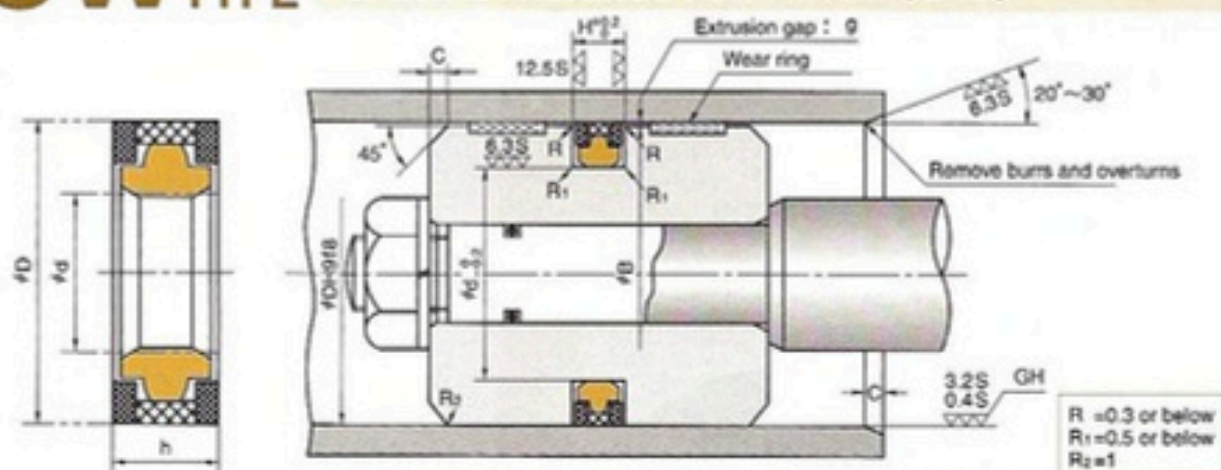

The inner surface of the cylinder tube should be finished by honing (GH) or burnishing (RLB) to 0.4 to 3.2 μm Rmax (0.1 to 0.8 μm Ra). Specially under severe lubricating condition, burnishing is required.

Nominal Number	Nominal Size of Packing			Housing dimensions				NOK Part Number
	d	D	h	ϕd	ϕD	H	C	
SPGW 50	36	50	8.5	36	50	9	4	GS0535V2
60	46	60	8.5	46	60			GS0528V2
63	48	63	10.5	48	63			GS3347V2
65	50	65	10.5	50	65	11	5	GS3013V2
70	55	70	10.5	55	70			GS0607V2
75	60	75	10.5	60	75			GS0995V2
80	65	80	10.5	65	80			GS0608V2
85	70	85	10.5	70	85			GS0813V2
90	75	90	10.5	75	90			GS0609V2
95	80	95	10.5	80	95			GS0481V4
100	85	100	12	85	100	12.5	5	GS0610V2
105	90	105	12	90	105			GS0973V2
110	95	110	12	95	110			GS0611V2
115	100	115	12	100	115	16	6.5	GS0626V2
120	105	120	12	105	120			GS0612V4
125	102	125	15.5	102	125			GS0583V2
130	107	130	15.5	107	130			GS0613V4
135	112	135	15.5	112	135			GS0908V4
140	117	140	15.5	117	140			GS0432V4
150	127	150	15.5	127	150			GS0614V4

HOW TO DETERMINE B DIMENSION

To determine ϕ B dimension, please refer to the graph in the right for the maximum extrusion gap (also refer page 26) considering the eccentricity of operating condition.

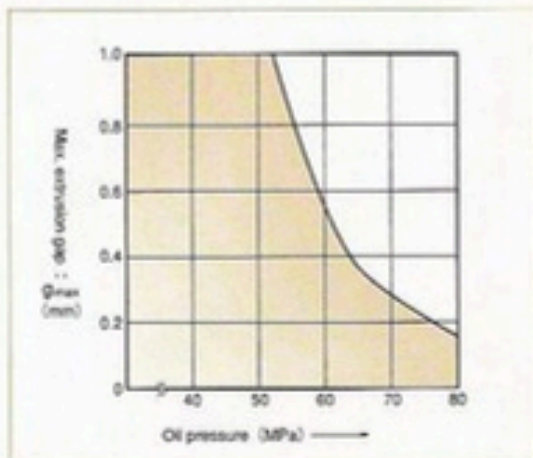

Nominal Number	Nominal Size of Packing			Housing dimensions				NOK Part Number
	d	D	h	ϕ d	ϕ D	H	C	
SPGW 160	137	160	15.5	137	160	16	6.5	GS0615V2
170	147	170	15.5	147	170			GS0688V2
180	157	180	15.5	157	180			GS0616V2
185	162	185	15.5	162	185			GS0653V2
190	167	190	15.5	167	190			GS0644V2
200	177	200	15.5	177	200			GS0617V2
210	187	210	15.5	187	210			GS0654V2
220	197	220	15.5	197	220			GS0655V2
225	202	225	15.5	202	225			GS0618V2
230	207	230	15.5	207	230			GS0664V2
240	217	240	15.5	217	240			GS0656V2
250	222	250	17	222	250			GS0451V4
260	232	260	17	232	260			GS0605V2
270	242	270	17	242	270			GS0689V2
280	252	280	17	252	280	GS0619V2		
300	272	300	17	272	300	GS0510V2		
320	292	320	17	292	320	GS0690V2		

SPGO_{TYPE}

SPECIAL PACKINGS FOR PISTON SEALS
RAREFLON(PTFE) + NITRILE RUBBER (NBR)



- Please designate NOK Part number and type & size on your order.

(Example) · Type Dimensions SPGO 14 20 3

Type Sign

Nominal Size of Packing
described in order of inner diameter(d), outer diameter(D), and height(h)

· Part Number GS1800V0

- Please check the application range on pages D-2 and 3 before selecting the type.

Material	NOK 19YF + NOK A305
----------	---------------------

SPGO TYPE SPECIAL PACKINGS FOR PISTON SEALS

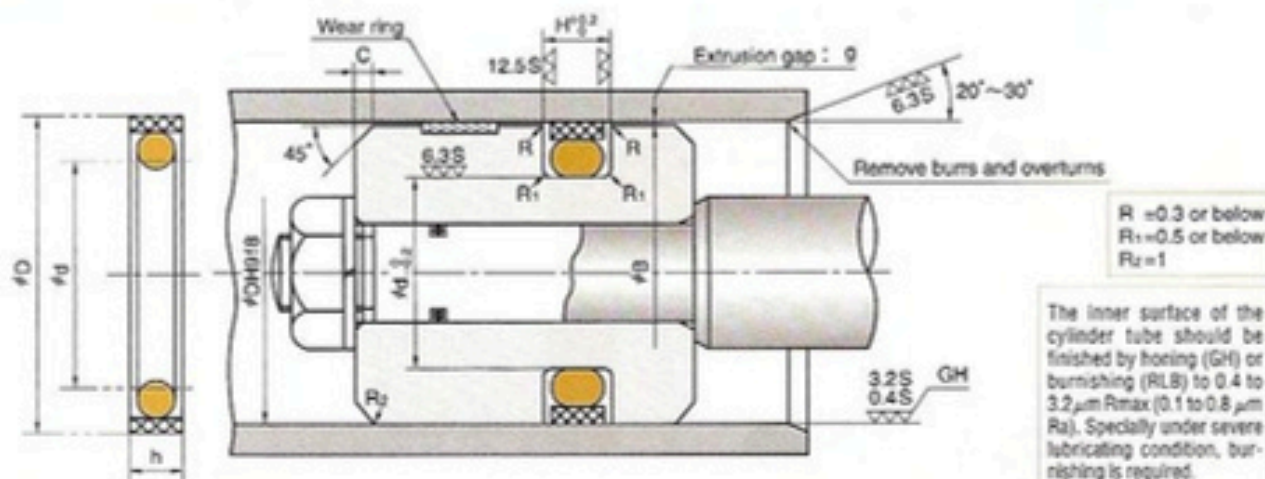

Nominal Number	Nominal Size of Packing			Housing dimensions				NOK Part Number
	d	D	h	#d	#D	H	C	
SPGO20	14	20	3	14	20	3.2	2	GS1800V0
25	19	25		19	25			GS1801V0
30	21.5	30	3.8	21.5	30	4	3.5	GS1802V0
31.5	23	31.5		23	31.5			GS1803V0
32	23.5	32		23.5	32			GS1804V0
35	26.5	35		26.5	35			GS1805V0
35.5	27	35.5		27	35.5			GS1806V0
40	31.5	40		31.5	40			GS1807V0
45	36.5	45		36.5	45			GS1808V0
50	41.5	50		41.5	50			GS1809V0
53	44.5	53		44.5	53			GS1810V0
55	46.5	55		46.5	55			GS1811V0
56	47.5	56	6.3	47.5	56	6.5	4	GS1812V0
60	51.5	60		51.5	60			GS1813V0
63	49	63		49	63			GS1814V0
65	51	65		51	65			GS1815V0
70	56	70		56	70			GS1816V0
71	57	71		57	71			GS1817V0
75	61	75		61	75			GS1818V0
80	66	80		66	80			GS1819V0
85	71	85		71	85			GS1820V0
90	76	90		76	90			GS1821V0
95	81	95	6.3	81	95	6.5	5	GS1822V0
100	86	100		86	100			GS1823V0
105	91	105		91	105			GS1824V0
110	96	110		96	110			GS1825V0

HOW TO DETERMINE B DIMENSION

To determine ϕ B dimension, please refer to the graph in the right for the maximum extrusion gap (also refer page 26) considering the eccentricity of operating condition.

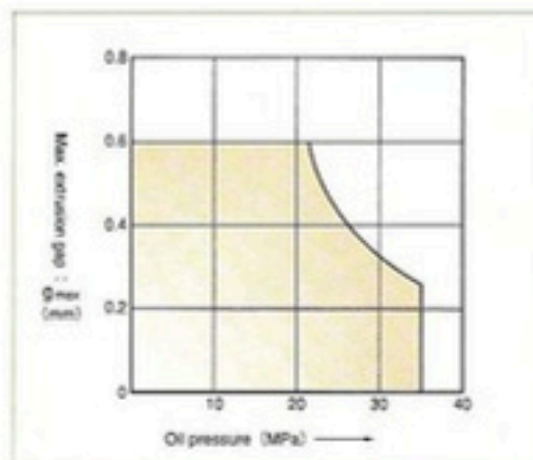

Nominal Number	Nominal Size of Packing			Housing dimensions				NOK Part Number
	d	D	h	ϕ d	ϕ D	H	C	
SPGO 112	98	112	6.3	98	112	6.5	6.5	GS1826V0
115	101	115		101	115			GS1827V0
120	106	120		106	120			GS1828V0
125	111	125		111	125			GS1829V0
130	116	130		116	130			GS1830V0
135	121	135		121	135			GS1831V0
140	126	140		126	140			GS1832V0
150	136	150		136	150			GS1833V0
160	146	160		146	160			GS1834V0
170	150	170		9.8	150			170
180	160	180	160		180	GS1836V0		
190	170	190	170		190	GS1837V0		
200	180	200	180		200	GS1838V0		
210	190	210	190		210	GS1839V0		
220	200	220	200		220	GS1840V0		
224	204	224	204		224	GS1841V0		
230	210	230	210		230	GS1842V0		
240	220	240	220		240	GS1843V0		
250	230	250	230		250	GS1844V0		
260	240	260	240		260	GS1845V0		
270	250	270	250		270	GS1846V0		
280	260	280	260		280	GS1847V0		
290	270	290	270		290	GS1848V0		
300	280	300	280		300	GS1849V0		
310	290	310	290		310	GS1850V0		
320	300	320	300		320	GS1851V0		
340	320	340	320		340	GS1852V0		
350	330	350	330	350	GS1853V0			
360	340	360	340	360	GS1854V0			
375	355	375	355	375	GS1855V0			
380	360	380	360	380	GS1856V0			
400	380	400	380	400	GS1857V0			

F

F

SPGC_{TYPE}

SPECIAL PACKINGS FOR PISTON SEALS
RAREFLON(PTFE) + NITRILE RUBBER (NBR)



- Please designate NOK Part number and type & size on your order.

(Example) · Type Dimensions SPGC 3 6 2.3

Type Sign

Nominal Size of Packing
described in order of inner diameter(d), outer diameter(D), and height(h)

· Part Number GS1000F0

- Please check the application range on pages D-2 and 3 before selecting the type.

Material	NOK 31BF + NOK A305
----------	---------------------

SPGC TYPE SPECIAL PACKINGS FOR PISTON SEALS

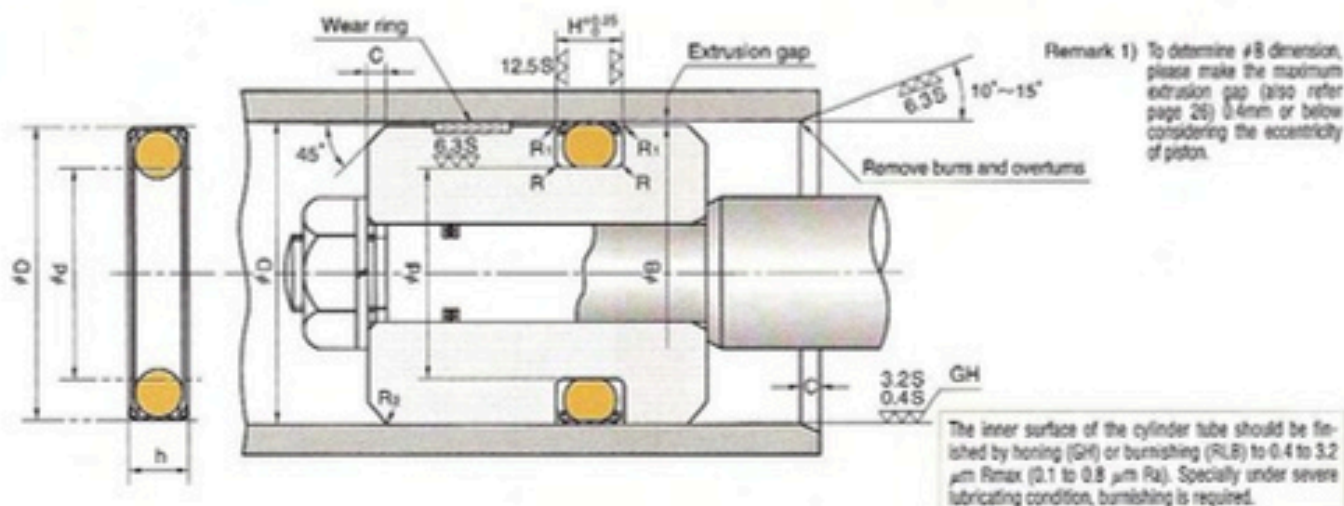

Nominal Number	Nominal Size of Packing			Housing dimensions								NOK Part Number
				For general hydraulic use				For pneumatic and hydraulic low-friction applications				
	d	D	h	#d	#D	#d	#D	#d	#D			
SPGC 6	3	6	2.3	3	6	2.5	6	2.5	0.3 or less	3~4	●GS1000F0	
7	4	7		4	7	3.5	7				●GS1001F0	
8	5	8		5	8	4.5	8				●GS1002F0	
9	6	9		6	9	5.5	9				●GS1003F0	
10	7	10		7	10	6.5	10				●GS1004F0	
11	8	11		8	11	7.5	11				●GS1005F0	
12	9	12		9	12	8.5	12				●GS1006F0	
13	10	13		10	13	9.5	13				●GS1007F0	
14	10	14		10	14	9.4	14				●GS1008F0	
15	11	15		11	15	10.4	15				●GS1009F0	
15.2	11.2	15.2	11.2	15.2	10.6	15.2	●GS1010F0					
16	12	16	3	12	16	11.4	16	3.2	0.4 or less	4~5	●GS1011F0	
16.5	12.5	16.5		12.5	16.5	11.9	16.5				●GS1012F0	
18	14	18		14	18	13.4	18				●GS1013F0	
19	15	19		15	19	14.4	19				●GS1014F0	
20	16	20		16	20	15.4	20				●GS1015F0	
22	18	22		18	22	17.4	22				●GS1016F0	
24	20	24		20	24	19.4	24				●GS1017F0	
25	21	25		21	25	20.4	25				●GS1018F0	
26	22	26		22	26	21.4	26				●GS1020F0	
28	22	28		22	28	21.4	28				●GS1019F0	
28.4	22.4	28.4	22.4	28.4	21.8	28.4	●GS1021F0					
30	24	30	4.4	24	30	23.4	30	4.7	0.7 or less	5~6	●GS1022F0	
31	25	31		25	31	24.4	31				●GS1023F0	
31.5	25.5	31.5		25.5	31.5	24.9	31.5				●GS1024F0	
32	26	32		26	32	25.4	32				●GS1025F0	
34	28	34		28	34	27.4	34				●GS1026F0	
35	29	35		29	35	28.4	35				●GS1027F0	
35.5	29.5	35.5		29.5	35.5	28.9	35.5				●GS1028F0	
36	30	36		30	36	29.4	36				●GS1029F0	
37	31	37		31	37	30.4	37				●GS1030F0	
37.5	31.5	37.5		31.5	37.5	30.9	37.5				●GS1031F0	
38	32	38	32	38	31.4	38	●GS1032F0					
40	34	40	34	40	33.4	40	●GS1033F0					
41	35	41	35	41	34.4	41	●GS1034F0					
41.5	35.5	41.5	35.5	41.5	34.9	41.5	●GS1035F0					
42	36	42	36	42	35.4	42	●GS1036F0					
44	38	44	38	44	37.4	44	●GS1037F0					
45	39	45	39	45	38.4	45	●GS1038F0					
46	40	46	40	46	39.4	46	●GS1039F0					

Remarks: When using packings with mark ●, provide separate grooves.

HOW TO DETERMINE B DIMENSION

To determine ϕB dimension, please refer to the graph in the right for the maximum extrusion gap (also refer page 26) considering the eccentricity of operating condition.

Nominal Number	Nominal Size of Packing			Housing dimensions								NOK Part Number
				For general hydraulic use				For pneumatic and hydraulic low-friction applications				
	d	D	h	ϕd	ϕD	ϕd	ϕD	H	R	C		
SPGC 47	41	47	4.4	41	47	40.4	47	4.7	0.7 or less	5~6	● GS1040F0	
48	42	48		42	48	41.4	48				● GS1041F0	
50	44	50		44	50	43.4	50				GS1042F0	
51	45	51		45	51	44.4	51				GS1043F0	
52	46	52		46	52	45.4	52				GS1044F0	
54	48	54		48	54	47.4	54				GS1046F0	
55	49	55		49	55	48.4	55				GS1047F0	
56	50	56		50	56	49.4	56				GS1049F0	
58	48	58		48	58	47.4	58				GS1045F0	
60	50	60		50	60	49.4	60				GS1048F0	
62	52	62	52	62	51.4	62	GS1050F0					
63	53	63	53	63	52.4	63	GS1051F0					
65	55	65	55	65	54.4	65	GS1052F0					
66	56	66	56	66	55.4	66	GS1053F0					
68	58	68	58	68	57.4	68	GS1054F0					
70	60	70	60	70	59.4	70	GS1055F0					
72	62	72	62	72	61.4	72	GS1056F0					
73	63	73	63	73	62.4	73	GS1057F0					
75	65	75	65	75	64.4	75	GS1058F0					
77	67	77	67	77	66.4	77	GS1059F0					
80	70	80	70	80	69.4	80	GS1060F0					
81	71	81	71	81	70.4	81	GS1061F0					
85	75	85	75	85	74.4	85	GS1062F0					
90	80	90	80	90	79.4	90	GS1063F0					
95	85	95	7	85	95	84.4	95	7.5	0.8 or less	6~8	GS1064F0	
100	90	100	90	100	89.4	100	GS1065F0					
105	95	105	95	105	94.4	105	GS1066F0					
110	100	110	100	110	99.4	110	GS1067F0					
112	102	112	102	112	101.4	112	GS1068F0					
115	105	115	105	115	104.4	115	GS1069F0					
120	110	120	110	120	109.4	120	GS1070F0					
122	112	122	112	122	111.4	122	GS1071F0					
125	115	125	115	125	114.4	125	GS1072F0					
130	120	130	120	130	119.4	130	GS1073F0					
135	125	135	125	135	124.4	135	GS1074F0					
140	130	140	130	140	129.4	140	GS1075F0					
142	132	142	132	142	131.4	142	GS1076F0					
145	135	145	135	145	134.4	145	GS1077F0					
150	140	150	140	150	139.4	150	GS1078F0					
155	145	155	145	155	144.4	155	GS1079F0					
160	150	160	150	160	149.4	160	GS1081F0					

Remarks: When using packings with mark ●, provide separate grooves.

SPGC TYPE SPECIAL PACKINGS FOR PISTON SEALS

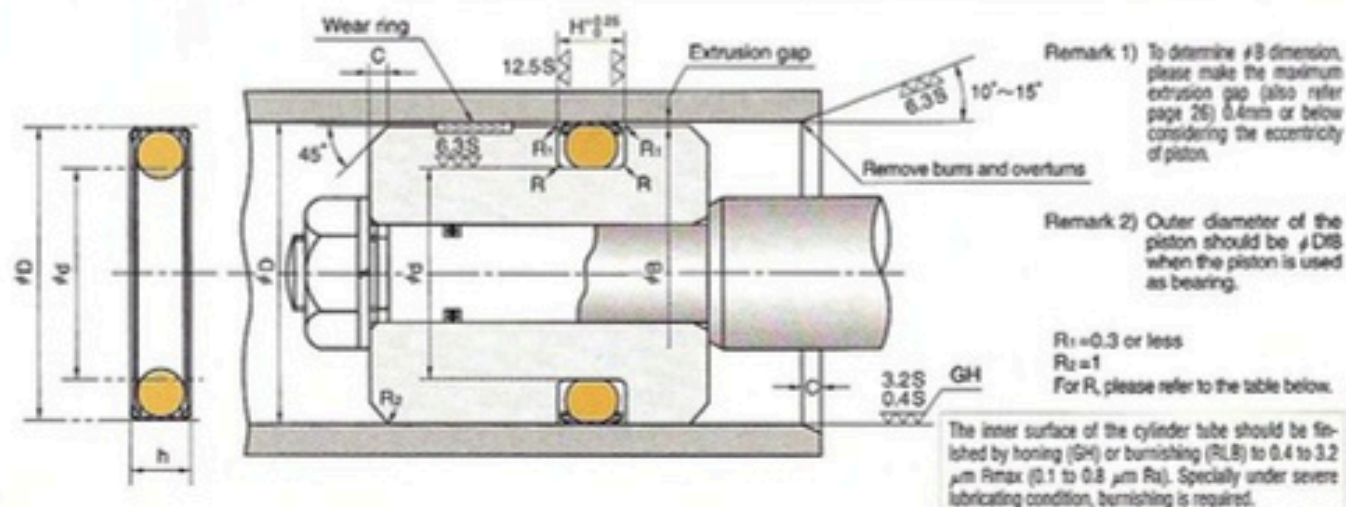

Nominal Number	Nominal Size of Packing			Housing dimensions								NOK Part Number
				For general hydraulic use				For pneumatic and hydraulic low-friction applications				
	d	D	h	#d	#D	#d	#D	H	R	C		
SPGC 165	150	165	10.5	150	165	149.4	165	11.0	0.8以下	8~12	GS1080F0	
170	155	170		155	170	154.4	170				GS1082F0	
175	160	175		160	175	159.4	175				GS1083F0	
180	165	180		165	180	164.4	180				GS1084F0	
185	170	185		170	185	169.4	185				GS1085F0	
190	175	190		175	190	174.4	190				GS1086F0	
195	180	195		180	195	179.4	195				GS1087F0	
200	185	200		185	200	184.4	200				GS1088F0	
205	190	205		190	205	189.4	205				GS1089F0	
210	195	210		195	210	194.4	210				GS1090F0	
215	200	215		200	215	199.4	215				GS1091F0	
220	205	220		205	220	204.4	220				GS1092F0	
224	209	224		209	224	208.4	224				GS1093F0	
225	210	225		210	225	209.4	225				GS1094F0	
230	215	230		215	230	214.4	230				GS1095F0	
235	220	235		220	235	219.4	235				GS1096F0	
240	225	240		225	240	224.4	240				GS1097F0	
245	230	245		230	245	229.4	245				GS1098F0	
250	235	250		235	250	234.4	250				GS1099F0	
255	240	255		240	255	239.4	255				GS1100F0	
260	245	260		245	260	244.4	260				GS1101F0	
265	250	265		250	265	249.4	265				GS1102F0	
270	255	270		255	270	254.4	270				GS1103F0	
275	260	275		260	275	259.4	275				GS1104F0	
280	265	280		265	280	264.4	280				GS1105F0	
285	270	285		270	285	269.4	285				GS1106F0	
290	275	290		275	290	274.4	290				GS1107F0	
295	280	295		280	295	279.4	295				GS1108F0	
300	285	300		285	300	284.4	300				GS1109F0	
305	290	305		290	305	289.4	305				GS1110F0	
310	295	310		295	310	294.4	310				GS1111F0	
315	300	315		300	315	299.4	315				GS1112F0	
330	315	330		315	330	314.4	330				GS1113F0	
335	320	335		320	335	319.4	335				GS1114F0	
350	335	350		335	350	334.4	350				GS1115F0	
355	340	355		340	355	339.4	355				GS1116F0	
370	355	370		355	370	354.4	370				GS1117F0	
375	360	375		360	375	359.4	375				GS1118F0	
390	375	390		375	390	374.4	390				GS1119F0	
400	385	400		385	400	384.4	400				GS1120F0	

SPGI_{TYPE}

SPECIAL PACKINGS FOR PISTON SEALS
RAREFLON(PTFE) + NITRILE RUBBER(NBR)



- Please designate NOK Part number and type & size on your order.

(Example) • Type Dimensions SPGI 30 20.5 4.3

Type Sign

Nominal Size of Packing
described in order of outer diameter(D), inner diameter(d), and height(h)

• Part Number FQ0497G0

- Please check the application range on pages D-2 and 3 before selecting the type.
- For application with extremely short stroke and/or under constant pressure, please consult.

Material	NOK U641 + NOK A980
----------	---------------------

SPGI TYPE SPECIAL PACKINGS FOR PISTON SEALS

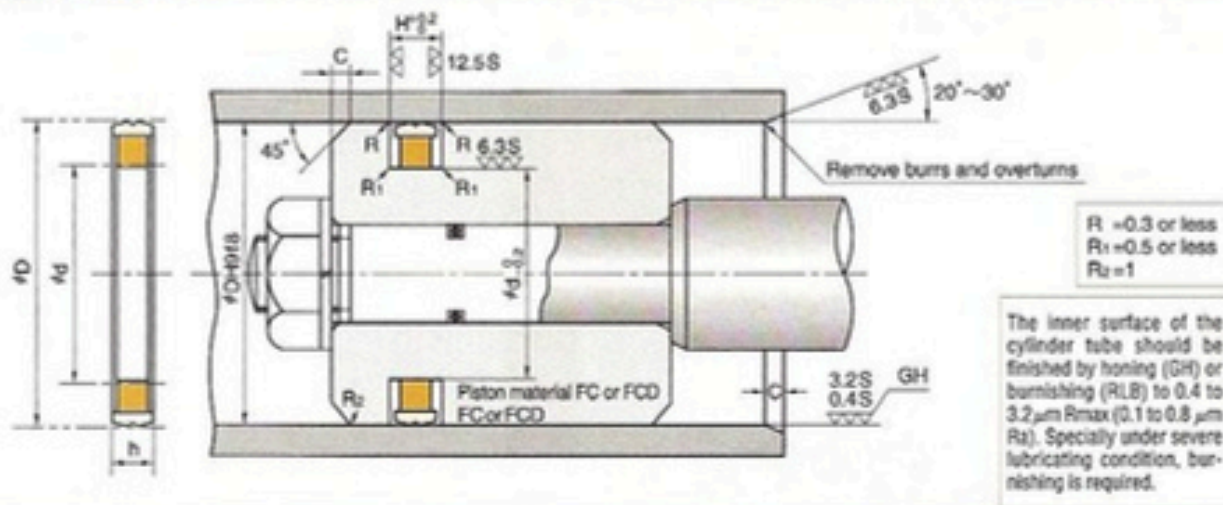

Nominal Number	Nominal Size of Packing			Housing dimensions				NOK Part Number
	D	d	h	ϕD	ϕd	H	C	
SPGI 30	30	20.5	4.3	30	20.5	4.5	2	FQ0497G0
31.5	31.5	22		31.5	22			FQ0498G0
32	32	22.5		32	22.5		FQ0499G0	
40	40	30		40	30		FQ0500G0	
50	50	40		50	40		FQ0501G0	
63	63	48	7.3	63	48	7.5	4	FQ0502G0
80	80	65		80	65			FQ0503G0
100	100	85		100	85		FQ0504G0	
125	125	109		125	109		FQ0505G0	
140	140	124		140	124		FQ0506G0	
160	160	144	10.8	160	144	11	6.5	FQ0507G0
180	180	158		180	158			FQ0508G0
200	200	178		200	178		FQ0509G0	
220	220	198		220	198		FQ0510G0	
224	224	202		224	202		FQ0511G0	
250	250	228	250	228	FQ0512G0			

CPI TYPE

SPECIAL PACKINGS FOR PISTON SEALS
NOXLAN (AU)



- Please designate NOK Part number and type & size on your order.

(Example) • Type Dimensions

CPI 25 10 2.5 10

Type Sign

Nominal Size of Packing
described in order of outer diameter(D), height(h), thickness(t),
and inner diameter(d)

• Part Number FC0013C0

- Please check the application range on pages D-2 and 3 before selecting the type.

Material	NOK U801
----------	----------

CPI TYPE SPECIAL PACKINGS FOR PISTON SEALS

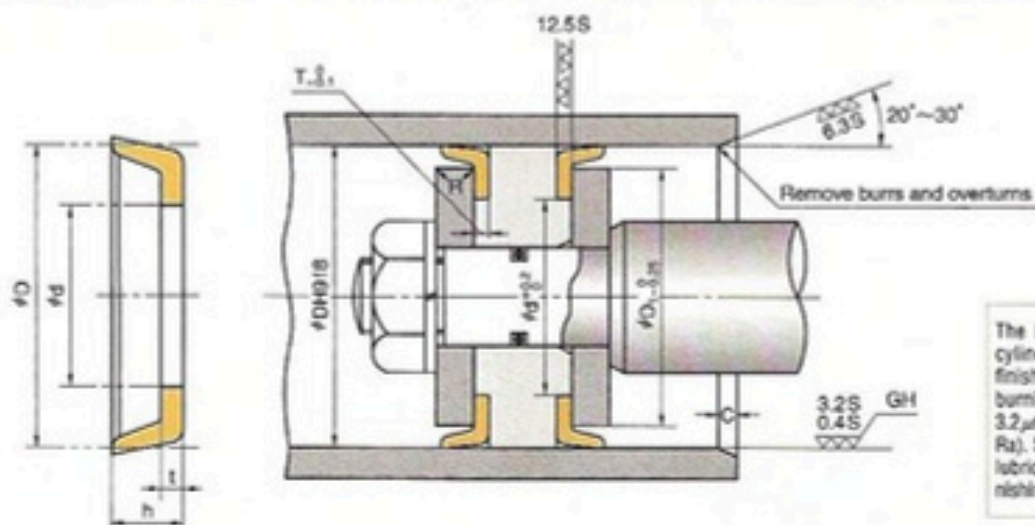

The inner surface of the cylinder tube should be finished by honing (GH) or burnishing (RLB) to 0.4 to 3.2 μm Rmax (0.1 to 0.8 μm Ra). Specially under severe lubricating condition, burnishing is required.

Nominal Size of Packing				Housing dimensions							NOK
D	h	t	d	#D	#D ₁	T	#d	R	C	Part Number	
25	10	2.5	10	25	17	2.4	10	1.5	3	FC0013C0	
28	10	2.5	10	28	20		10			FC0015C0	
30	10	2.5	12	30	22		12			FC0020C0	
31.5	10	2.5	14	31.5	23.5		14			FC0022C0	
35	10	2.5	16	35	27		16			FC0026C0	
35.5	10	2.5	16	35.5	27.5		16			FC0398C0	
40	10	2.5	20	40	32	2.9	20	2	FC0035C0		
45	12	3	20	45	36		20		FC0046C0		
50	12	3	22	50	41		22		FC0055C0		
53	12	3	25	53	44		25		FC0064C0		
55	12	3	25	55	46		25		FC0068C0		
56	12	3	25	56	47		25		FC0070C0		
60	12	3	30	60	51		30		FC0077C0		
63	12	3	35	63	54		35		FC0090C0		
65	12	3	35	65	56		35		FC0095C0		
67	12	3	38	67	58		38		FC0102C1		
70	12	3	38	70	61	3.8	38	3.5	FC0106C0		
71	12	3	40	71	62		40		FC0114C0		
75	12	3	40	75	66		40		FC0117C0		
80	16	4	40	80	69		40		FC0134C0		
85	16	4	45	85	74		45		FC0142C0		
90	16	4	50	90	79		50		FC0157C0		
95	16	4	55	95	84		55		FC0164C0		
100	16	4	55	100	89		55		FC0174C0		
105	16	4	60	105	94		60		FC0187C0		
106	16	4	60	106	95		60		FC0189C0		
110	16	4	60	110	99	60	FC0195C0				
112	16	4	65	112	101	65	FC0199C0				
118	16	4	70	118	107	70	FC0205C0				
120	16	4	70	120	109	70	FC0207C0				
125	20	5	75	125	111	4.8	75	4	FC0222C0		
130	20	5	80	130	116		80		FC0230C0		
132	20	5	85	132	118		85		FC0233C1		
140	20	5	90	140	126		90		FC0245C1		
150	20	5	100	150	136		100		FC0255C1		
160	20	5	110	160	146		110		FC0275C0		
170	20	5	120	170	156		120		FC0279C0		
180	20	5	130	180	166		130		FC0282C1		
190	20	5	140	190	176		140		FC0289C0		
200	20	5	150	200	186		150		FC0293C0		
224	20	5	180	224	210		180		FC0314C0		
250	20	5	200	250	236		200		FC0321C0		
280	20	5	230	280	266		230		6.5	7	FC0337C0
300	20	5	250	300	286		250				FC0344C1

CPH^{TYPE}

SPECIAL PACKINGS FOR PISTON SEALS
NITRILE RUBBER (NBR)



- Please designate NOK Part number and type & size on your order.

(Example) • Type Dimensions

CPH 30 8 2.5 13

Type Sign

Nominal Size of Packing
described in order of outer diameter(D), height(h), thickness(t),
and inner diameter(d)

• Part Number

CC0019C3

- Please check the application range on pages D-2 and 3 before selecting the type.

Material	NOK A102 NOK A103 NOK A104 NOK A505
-----------------	--

CPH TYPE SPECIAL PACKINGS FOR PISTON SEALS

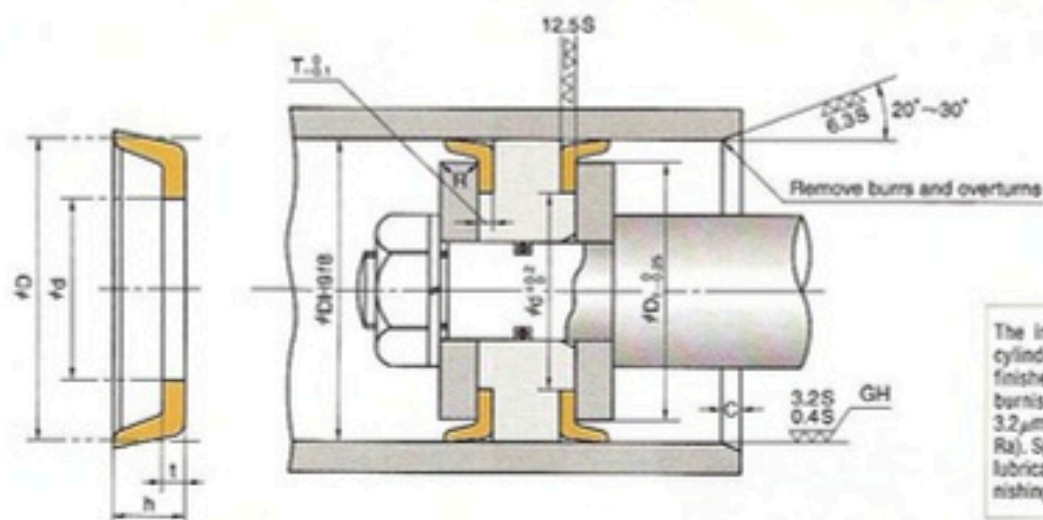

Nominal Size of Packing				Housing dimensions						NOK Part Number	NOK rubber material Sign
D	h	t	d	φD	φD ₁	T	φd	R	C		
30	8	2.5	13	30	23	2.5	13	1.5	7	CC0019C3	A104
	10	2.5	12	30	23.5	2.5	12			CC0020C0	A103
	10	2.5	15	30	23	2.5	15			CC0020C1	A102
35	10	2.5	18	35	28.5	2.5	18	2	7	CC0026C0	A102
	40	8	2.5	16	40	33	2.5			16	CC0034C1
40	10	2.5	20	40	33.5	2.5	20	2	7	CC0035C0	A102
	42	12	3	23	42	34	3			23	CC0040C0
45	10	2.5	25	45	38.5	2.5	25	2	7	CC0044C0	A102
50	12	3	25	50	41.5	3	25			CC0055C1	A104
55	10	3	40	55	48	3	40	2	7	CC0067C0	A103
	60	8	2.5	40.5	60	54	2.5			40.5	CC0074C0
65	12	3	30	60	51	3	30	2	7	CC0077C0	A505
	65	13	3.5	34.5	65	56	3.5			34.5	CC0096C0
70	12	3	38	70	62	3	38	2	7	CC0106C2	A505
75	12	3	38	75	66	3	38			CC0117C1	A104
80	15	4	40	80	70	4	40	2	7	CC0132C0	A505
	16	4	40	80	69	4	40			CC0134C0	A102
90	15	4.3	38	90	80	4.3	38	3	8	CC0156C0	A505
	16	4	45	90	79.5	4	45			CC0157C0	A102
	17	5	50	90	77	5	50			CC0159C0	A104
100	15	4.3	38	100	88	4.3	38	3	8	CC0171C0	A104
	16	4	50	100	89	4	50			CC0174C5	A104
	16	4	55	100	89	4	55			CC0174C4	A505
120	16	4	60	120	109	4	60	3	8	CC0207C0	A102
	16	4	70	120	109	4	70			CC0207C1	A104
125	16	5	75	125	115	5	75	3	8	CC0219C0	A104
130	20	5	80	130	116	5	80			CC0230C1	A104
150	20	5	75	150	136	5	75	3	8	CC0255C0	A102
	20	5	100	150	138	5	100			CC0255C2	A505
160	20	5	90	180	166.5	5	90	4	11	CC0282C0	A102
	25	5	80	180	166	5	80			CC0285C0	A104
	200	20	5	150	200	187	5			150	CC0293C5
205	23	4	134	205	190	4	134	4	11	CC0303C1	A103
257	22	5.5	192	257	245	5.5	192			CC0328C1	A103

IDI TYPE

SPECIAL PACKINGS FOR ROD SEALS
NOXLAN (AU)



- Please designate NOK Part number and type & size on your order.

(Example) • Type Dimensions IDI 6.3 14.3 5
 └─ Type Sign └─ Nominal Size of Packing
 described in order of inner diameter(d), outer diameter(D), and height(h)

• Part Number FU0021F0

- Please check the application range on pages D-2 and 3 before selecting the type.

Material	NOK U801
----------	----------

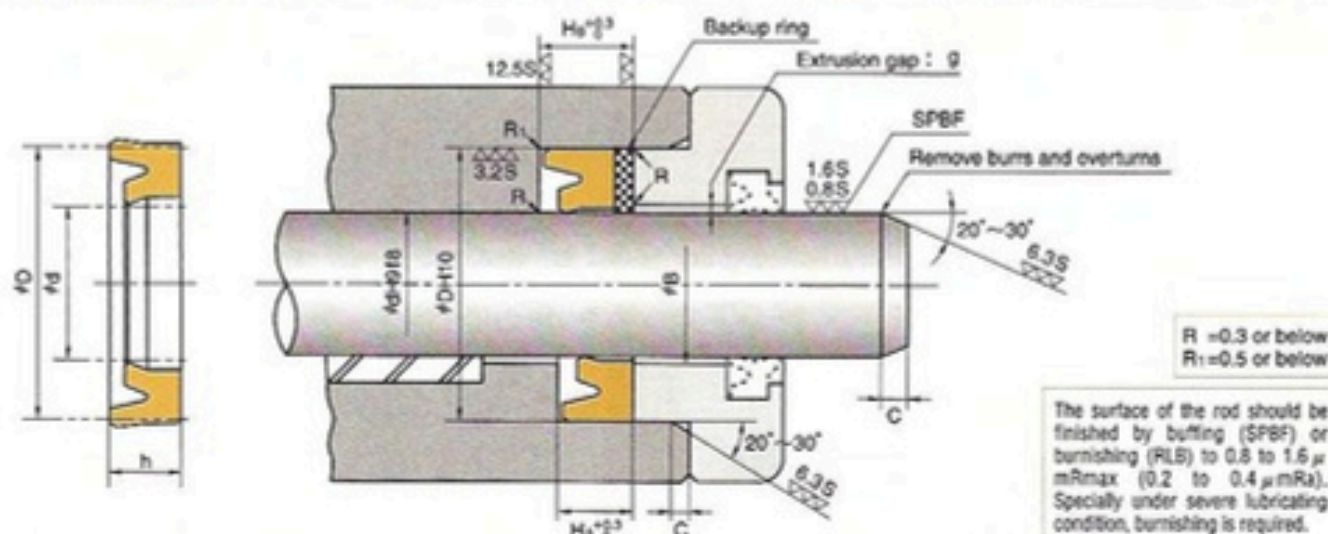

Nominal Size of Packing			Housing dimensions				C	NOK Part Number
d	D	h	ϕd	ϕD	H_A	H_B		
6.3	14.3	5	6.3	14.3	5.7	7.7	2.5	※ FU0021F0
	16.3	6	6.3	16.3	7	9		※ FU0022F0
	16.3	7.5	6.3	16.3	8.5	10.5		FU0023F0
	16.3	8	6.3	16.3	9	11		FU0024F0
8	16	5	8	16	5.7	7.7		※ FU0039F0
	18	6	8	18	7	9		※ FU0041F0
	18	7.5	8	18	8.5	10.5		FU0042F0
	18	8	8	18	9	11		FU0043F0
9	17	5	9	17	5.7	7.7		※ FU0051F0
	19	6	9	19	7	9		※ FU0052F0
	19	7.5	9	19	8.5	10.5		FU0053F0
	19	8	9	19	9	11		FU0054F0
10	18	5	10	18	5.7	7.7		※ FU0064F0
	20	6	10	20	7	9		※ FU0066F0
	20	7.5	10	20	8.5	10.5		FU0068F0
	20	8	10	20	9	11		FU0069F0
11.2	19.2	5	11.2	19.2	5.7	7.7	※ FU0078F0	
	21.2	6	11.2	21.2	7	9	※ FU0079F0	
	21.2	7.5	11.2	21.2	8.5	10.5	FU0080F0	
	21.2	8	11.2	21.2	9	11	FU0081F0	
12.5	20.5	5	12.5	20.5	5.7	7.7	※ FU0098F0	
	22.5	6	12.5	22.5	7	9	※ FU0100F0	
	22.5	7.5	12.5	22.5	8.5	10.5	FU0101F0	
	22.5	8	12.5	22.5	9	11	FU0102F0	
14	22	5	14	22	5.7	7.7	※ FU0116F0	
	24	6	14	24	7	9	※ FU0120F0	
	24	7.5	14	24	8.5	10.5	FU0121F0	
	24	8	14	24	9	11	FU0122F0	
15	23	5	15	23	5.7	7.7	※ FU0131F0	
	25	6	15	25	7	9	※ FU0134F0	
	25	8	15	25	9	11	FU0135F0	
	28	8	15	28	9	11	FU0136F0	
16	24	5	16	24	5.7	7.7	※ FU0150F0	
	26	6	16	26	7	9	※ FU0155F0	
	26	7.5	16	26	8.5	10.5	FU0156F0	
	26	8	16	26	9	11	FU0157F0	
18	28	6	18	28	7	9	※ FU0181F0	
	28	8	18	28	9	11	FU0182F0	
	31	8	18	31	9	11	FU0185F0	
	31	10	18	31	11	13	FU0186F0	

The dimensions and pressure limits with ※ are the same as those of ISI type.

HOW TO DETERMINE B DIMENSION

■ When using backup ring

Please determine B dimension according to the table below. If you require larger B dimension because of the cylinder configuration, please consult NOK.

Maximum Service Pressure	14MPa	21MPa	35MPa
Material of Backup ring	19YF		
B Dimension	$B \leq \phi d + 1.0$	$B \leq \phi d + 0.5$	$B \leq \phi d + 0.2$
Maximum Service Pressure	35MPa	42MPa	70MPa
Material of Backup ring	80NP		
B Dimension	$B \leq \phi d + 0.8$	$B \leq \phi d + 0.4$	$B \leq \phi d + 0.2$

■ When not using backup ring

To determine ϕ B dimension, please refer to the graph in the right for the maximum extrusion gap (also refer page 26) considering the eccentricity of operating condition.

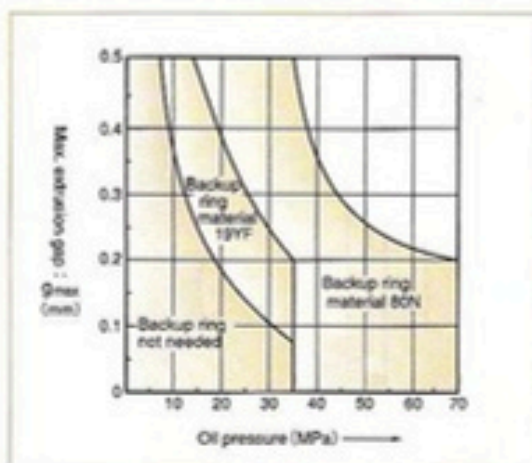

Nominal Size of Packing			Housing dimensions				C	NOK Part Number
d	D	h	ϕd	ϕD	H _a	H _b		
20	30	6	20	30	7	9	3.5	※ FU0214F0
	30	8	20	30	9	11		FU0215F0
	33	8	20	33	9	11		FU0220F0
	33	10	20	33	11	13		FU0221F0
22	35	10	22	35	11	13		FU0249F0
22.4	32.4	6	22.4	32.4	7	9		※ FU0262F0
	32.4	8	22.4	32.4	9	11		FU0263F0
	35.4	8	22.4	35.4	9	11		FU0264F0
	35.4	10	22.4	35.4	11	13		FU0265F0
25	35	6	25	35	7	9		※ FU0279F0
	35	8	25	35	9	11		FU0282F0
	38	8	25	38	9	11		FU0287F0
	38	10	25	38	11	13	FU0288F0	
	40	9	25	40	10	12	FU0291F0	
	40	10	25	40	11	13	FU0292F0	
27	40	10	27	40	11	14	FU2130F0	
28	38	6	28	38	7	10	※ FU0322F0	
	38	8	28	38	9	12	FU0323F0	
	41	8	28	41	9	12	FU0334F0	
	41	10	28	41	11	14	FU0335F0	
	43	9	28	43	10	13	FU0339F0	
	43	10	28	43	11	14	FU0340F0	
30	40	8	30	40	9	12	FU0359F0	
	43	10	30	43	11	14	FU0364F0	
	45	9	30	45	10	13	FU0367F0	
	45	10	30	45	11	14	FU0368F0	
31.5	41.5	8	31.5	41.5	9	12	FU0383F0	
	44.5	8	31.5	44.5	9	12	FU0384F0	
	44.5	10	31.5	44.5	11	14	FU0385F0	
	46.5	9	31.5	46.5	10	13	FU0386F0	
	46.5	10	31.5	46.5	11	14	FU0387F0	
34	50	12	34	50	13	16	FU0408F0	
35	45	8	35	45	9	12	FU0427F0	
	50	9	35	50	10	13	FU0436F0	
	50	10	35	50	11	14	FU0437F0	
	50	12	35	50	13	16	FU0438F0	
35.5	45.5	8	35.5	45.5	9	12	FU0453F0	
	50.5	9	35.5	50.5	10	13	FU0455F0	
	50.5	10	35.5	50.5	11	14	FU0456F0	
	51.5	10	35.5	51.5	11	14	FU0457F0	
	51.5	12	35.5	51.5	13	16	FU0458F0	

The dimensions and pressure limits with ※ are the same as those of ISI type.

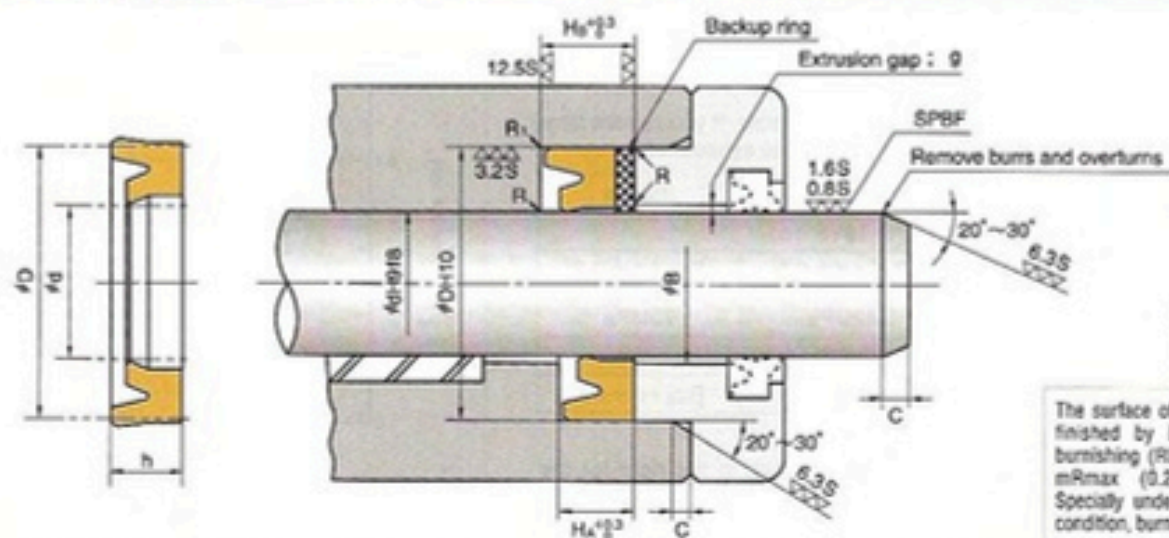

R = 0.3 or below
R₁ = 0.5 or below

The surface of the rod should be finished by buffing (SPBF) or burnishing (RLB) to 0.8 to 1.6 μm Rmax (0.2 to 0.4 μm Ra). Specially under severe lubricating condition, burnishing is required.

Nominal Size of Packing			Housing dimensions				C	NOK Part Number
d	D	h	#d	#D	H _A	H _B		
40	50	8	40	50	9	12	4	FU0498F0
	55	9	40	55	10	13		FU0504F0
	55	10	40	55	11	14		FU0505F0
	56	10	40	56	11	14		FU0508F0
	56	12	40	56	13	16		FU0509F0
45	55	8	45	55	9	12		FU0569F0
	60	9	45	60	10	13		FU0575F0
	60	10	45	60	11	14		FU0577F0
	61	10	45	61	11	14		FU0579F0
	61	12	45	61	13	16		FU0580F0
47	63	12	47	63	13	16		FU0591F0
50	60	8	50	60	9	12		FU0620F0
	65	9	50	65	10	13		FU0630F0
	65	10	50	65	11	14		FU0631F0
	66	10	50	66	11	14		FU0634F0
	66	12	50	66	13	16		FU0635F0
	70	12	50	70	13	16		FU0639F0
	70	12	50	70	13	16		FU0682F0
53	69	12	53	69	13	16		FU0682F0
55	65	8	55	65	9	12		FU0696F0
	70	9	55	70	10	13	FU0700F0	
	70	10	55	70	11	14	FU0701F0	
	71	10	55	71	11	14	FU0703F0	
	71	12	55	71	13	16	FU0704F0	
	75	12	55	75	13	16	FU0708F0	
56	66	8	56	66	9	12	FU0723F0	
	71	9	56	71	10	13	FU0724F0	
	71	10	56	71	11	14	FU0725F0	
	72	10	56	72	11	14	FU0726F0	
	72	12	56	72	13	16	FU0727F0	
	76	12	56	76	13	16	FU0728F0	
	76	12	56	76	13	16	FU0728F0	
60	70	8	60	70	9	12	FU0747F0	
	75	9	60	75	10	13	FU0753F0	
	75	10	60	75	11	14	FU0754F0	
	76	10	60	76	11	14	FU0756F0	
	76	12	60	76	13	16	FU0757F0	
	80	12	60	80	13	16	FU0761F0	
63	73	8	63	73	9	12	FU0787F0	
	78	9	63	78	10	13	FU0788F0	
	78	10	63	78	11	14	FU0789F0	
	79	10	63	79	11	14	FU0790F0	
	79	12	63	79	13	16	FU0791F0	
	83	12	63	83	13	16	FU0793F0	

HOW TO DETERMINE B DIMENSION

■ When using backup ring

Please determine B dimension according to the table below. If you require larger B dimension because of the cylinder configuration, please consult NOK.

Maximum Service Pressure	14MPa	21MPa	35MPa
Material of Backup ring	19YF		
B Dimension	$B \leq \phi d + 1.0$	$B \leq \phi d + 0.5$	$B \leq \phi d + 0.2$

Maximum Service Pressure	35MPa	42MPa	70MPa
Material of Backup ring	80NP		
B Dimension	$B \leq \phi d + 0.8$	$B \leq \phi d + 0.4$	$B \leq \phi d + 0.2$

■ When not using backup ring

To determine ϕB dimension, please refer to the graph in the right for the maximum extrusion gap (also refer page 26) considering the eccentricity of operating condition.

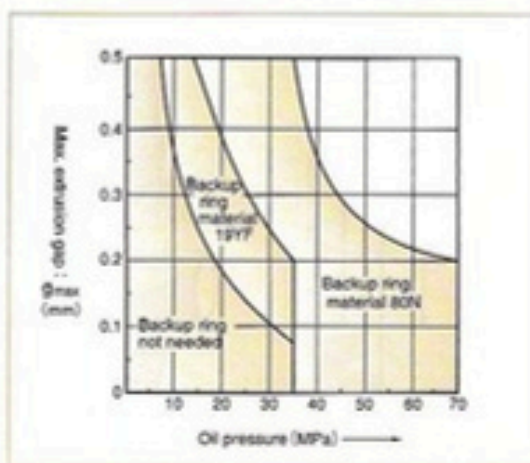

Nominal Size of Packing			Housing dimensions				C	NOK Part Number
d	D	h	ϕd	ϕD	H _A	H _B		
64	80	12	64	80	13	16	4	FU2131F0
65	75	8	65	75	9	12		FU0810F0
	80	9	65	80	10	13		FU0815F0
	80	12	65	80	13	16		FU0816F0
	85	12	65	85	13	16		FU0819F0
67	82	9	67	82	10	13		FU0830F0
	87	15	67	87	16	19		FU0832F0
70	80	8	70	80	9	12		FU0850F0
	85	9	70	85	10	13		FU0857F0
	85	10	70	85	11	14		FU0858F0
	90	12	70	90	13	16		FU0862F0
	90	15	70	90	16	19		FU0864F0
71	81	8	71	81	9	12		FU0881F0
	86	9	71	86	10	13		FU0882F0
	86	10	71	86	11	14		FU0883F0
	91	12	71	91	13	16		FU0884F0
	91	15	71	91	16	19	FU0885F0	
75	85	8	75	85	9	12	5	FU0903F0
	90	9	75	90	10	13		FU0906F0
	90	10	75	90	11	14		FU0907F0
	95	12	75	95	13	16		FU0910F0
	95	15	75	95	16	19		FU0911F0
	80	90	8	80	90	9		12
95		9	80	95	10	13		FU0942F0
95		10	80	95	11	14		FU0943F0
100		12	80	100	13	16		FU0948F0
100		15	80	100	16	19		FU0949F0
85	100	10	85	100	11	14		FU0985F0
	105	12	85	105	13	16		FU0989F0
	105	15	85	105	16	19		FU0990F0
90	105	10	90	105	11	14		FU1025F0
	110	12	90	110	13	16		FU1030F1
	110	15	90	110	16	19		FU1031F0
95	110	10	95	110	11	14	FU1052F0	
	115	12	95	115	13	16	FU1056F0	
	115	15	95	115	16	19	FU1057F0	

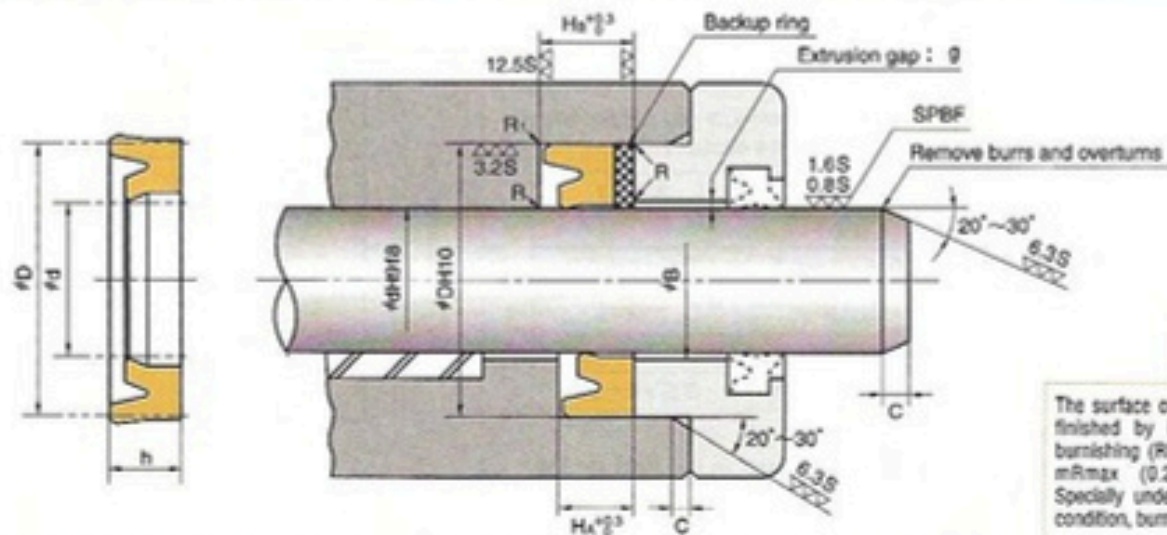

R = 0.3 or below
R₁ = 0.5 or below

The surface of the rod should be finished by buffing (SPBF) or burnishing (RLS) to 0.8 to 1.6 μm R_{max} (0.2 to 0.4 μm R_a). Specially under severe lubricating condition, burnishing is required.

Nominal Size of Packing			Housing dimensions				C	NOK Part Number
d	D	h	φd	φD	H _a	H _b		
100	115	10	100	115	11	14	5	FU1083F0
	120	12	100	120	13	16		FU1089F0
	120	15	100	120	16	19		FU1091F0
105	120	10	105	120	11	14		FU1126F0
	125	15	105	125	16	19		FU1129F0
	125	16	105	125	17	20		FU1130F0
106	121	10	106	121	11	14		FU1137F0
	126	15	106	126	16	19		FU1138F0
	126	16	106	126	17	20		FU1139F0
110	125	10	110	125	11	14		FU1158F0
	130	15	110	130	16	19		FU1165F0
	130	16	110	130	17	20		FU1166F0
112	127	9	112	127	10	13		FU1180F0
	127	10	112	127	11	14		FU1181F0
	132	15	112	132	16	19		FU1182F0
	132	16	112	132	17	20	FU1183F0	
118	133	10	118	133	11	14	FU1206F0	
	138	15	118	138	16	19	FU1207F0	
	138	16	118	138	17	20	FU1208F0	
120	135	10	120	135	11	14	FU1221F0	
	140	15	120	140	16	19	FU1224F0	
	140	16	120	140	17	20	FU1225F0	
125	140	10	125	140	11	14	FU1253F0	
	145	12	125	145	13	16	FU1256F0	
	145	16	125	145	17	20	FU1258F0	
	150	19	125	150	20	23	FU2132F0	
	150	20	125	150	21	24	FU1260F0	
130	145	10	130	145	11	14	FU1281F0	
	150	12	130	150	13	16	FU1283F0	
	150	16	130	150	17	20	FU1285F0	
132	157	20	132	157	21	24	FU1295F0	
135	160	19	135	160	20	23	FU2133F0	
	160	20	135	160	21	24	FU2179F0	
140	155	10	140	155	11	14	FU1324F0	
	160	12	140	160	13	16	FU1325F0	
	160	16	140	160	17	20	FU1328F0	
	165	19	140	165	20	23	FU1332F0	
	165	20	140	165	21	24	FU1333F0	
145	170	19	145	170	20	23	FU2134F0	
	170	20	145	170	21	24	FU2180F0	
						6.5		

HOW TO DETERMINE B DIMENSION

■ When using backup ring

Please determine B dimension according to the table below. If you require larger B dimension because of the cylinder configuration, please consult NOK.

Maximum Service Pressure	14MPa	21MPa	35MPa
Material of Backup ring	19YF		
B Dimension	$B \leq \phi d + 1.0$	$B \leq \phi d + 0.5$	$B \leq \phi d + 0.2$
Maximum Service Pressure	35MPa	42MPa	70MPa
Material of Backup ring	80NP		
B Dimension	$B \leq \phi d + 0.8$	$B \leq \phi d + 0.4$	$B \leq \phi d + 0.2$

■ When not using backup ring

To determine ϕB dimension, please refer to the graph in the right for the maximum extrusion gap (also refer page 26) considering the eccentricity of operating condition.

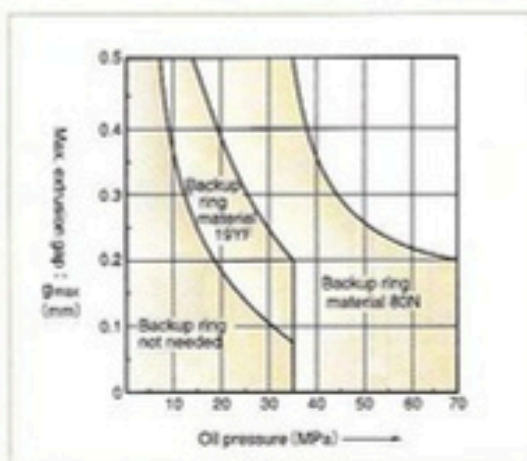

Nominal Size of Packing			Housing dimensions				C	NOK Part Number
d	D	h	ϕd	ϕD	H ₁	H ₂		
150	165	10	150	165	11	14	6.5	FU1360F0
	170	12	150	170	13	16		FU1361F0
	170	16	150	170	17	20		FU1364F0
	175	16	150	175	17	20		FU1366F0
	175	20	150	175	21	24		FU1368F0
155	180	19	155	180	20	24		FU1393F0
	180	20	155	180	21	25		FU2181F0
160	175	10	160	175	11	15		FU1407F0
	180	12	160	180	13	17		FU1409F0
	180	16	160	180	17	21		FU1412F0
	185	16	160	185	17	21		FU1414F0
	185	19	160	185	20	24		FU2076F0
	185	20	160	185	21	25		FU1416F0
170	185	10	170	185	11	15		FU1444F0
	190	12	170	190	13	17		FU1445F0
	190	16	170	190	17	21		FU1447F0
	195	16	170	195	17	21		FU1449F0
	195	20	170	195	21	25		FU1450F0
175	200	19	175	200	20	24		FU1463F0
	200	20	175	200	21	25		FU2182F0
180	200	16	180	200	17	21	FU1486F0	
	205	16	180	205	17	21	FU1491F0	
	205	19	180	205	20	24	FU1492F0	
	205	20	180	205	21	25	FU1493F0	
190	210	16	190	210	17	21	FU1518F0	
	215	16	190	215	17	21	FU1520F0	
	215	20	190	215	21	25	FU1521F0	
199	219	11	199	219	12	16	FU1530F0	
	219	15	199	219	16	20	FU1531F0	
	224	16	199	224	17	21	FU1533F0	
	224	19	199	224	20	24	FU1535F0	
200	220	16	200	220	17	21	FU1545F0	
	225	16	200	225	17	21	FU1548F0	
	225	19	200	225	20	24	FU2135F0	
	225	20	200	225	21	25	FU1550F0	
210	230	16	210	230	17	21	FU1576F0	
	235	16	210	235	17	21	FU1578F0	
	235	19	210	235	20	24	FU1580F0	
	235	20	210	235	21	25	FU1581F0	
220	240	16	220	240	17	21	FU1597F0	
	245	16	220	245	17	21	FU1598F0	
	245	19	220	245	20	24	FU1600F0	
	245	20	220	245	21	25	FU1601F0	

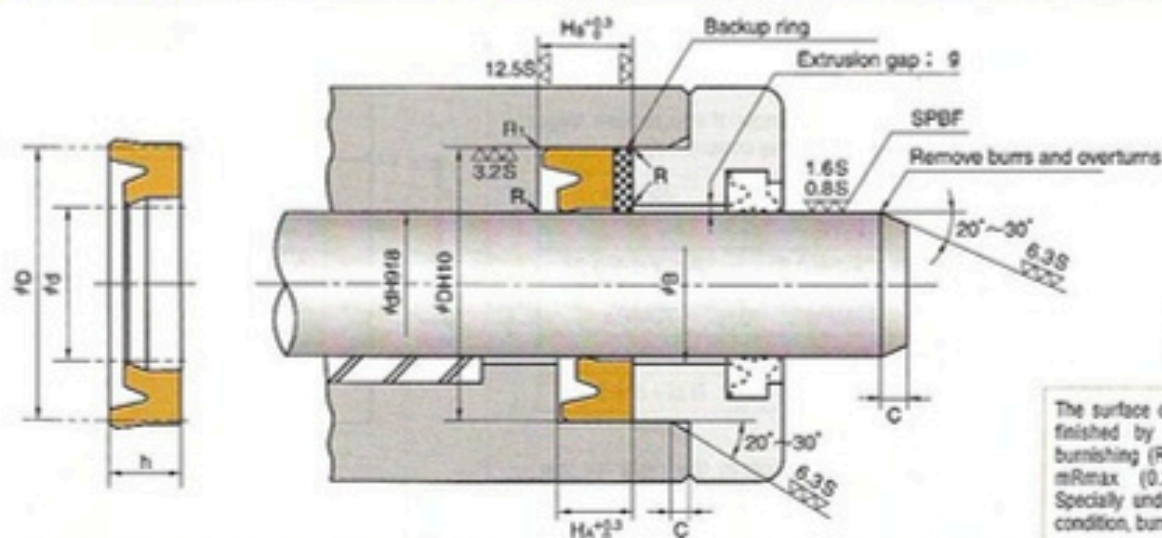

Nominal Size of Packing			Housing dimensions				C	NOK Part Number
d	D	h	ϕd	ϕD	H_k	H_b		
224	244	11	224	244	12	16	6.5	FU1608F0
	244	15	224	244	16	20		FU1610F0
	249	15	224	249	16	20		FU1611F0
	249	18	224	249	19	23		FU1612F0
	249	19	224	249	20	24		FU1613F0
225	245	16	225	245	17	21		FU1622F0
	250	16	225	250	17	21		FU1624F0
	250	19	225	250	20	24		FU1626F0
	250	20	225	250	21	25		FU1627F0
230	250	16	230	250	17	21		FU1638F0
	255	16	230	255	17	21		FU1640F0
	255	19	230	255	20	24		FU1642F0
240	255	20	230	255	21	25		FU1643F0
	260	16	240	260	17	21		FU1658F0
	265	16	240	265	17	21		FU1661F0
	265	19	240	265	20	24	FU1663F0	
250	265	20	240	265	21	25	FU1664F0	
	270	16	250	270	17	21	FU1679F0	
	275	16	250	275	17	21	FU1681F0	
	275	19	250	275	20	24	FU1683F0	
260	275	20	250	275	21	25	FU1684F0	
	285	19	260	285	20	24	FU1705F0	
	290	19	260	290	20	24	FU1707F0	
265	297	24	265	297	25	29	FU1714F0	
	297	25	265	297	26	30	FU2183F0	
270	295	19	270	295	20	24	FU1721F0	
	300	19	270	300	20	24	FU1723F0	
	300	24	270	300	25	29	FU1725F0	
	300	25	270	300	26	30	FU1726F0	
280	305	19	280	305	20	24	FU1734F0	
	310	19	280	310	20	24	FU1736F0	
	312	24	280	312	25	29	FU2136F0	
	312	25	280	312	26	30	FU2184F0	
290	315	19	290	315	20	24	FU1749F0	
	320	19	290	320	20	24	FU1751F0	
300	325	19	300	325	20	24	FU1763F0	
	330	19	300	330	20	24	FU1765F0	
	332	24	300	332	25	29	FU2137F0	
	332	25	300	332	26	30	FU2185F0	

ISI TYPE

SPECIAL PACKINGS FOR ROD SEALS NOXLAN (AU)



- Please designate NOK Part number and type & size on your order.

(Example) • Type Dimensions

ISI 18 26 5

Type Sign

Nominal Size of Packing
described in order of inner diameter(d), outer diameter(D), and height(h)

• Part Number FU0180K0

- Please check the application range on pages D-2 and 3 before selecting the type.

Material	Standard : NOK U801 Heat Resistant type : NOK U641
-----------------	---

ISI TYPE SPECIAL PACKINGS FOR ROD SEALS (INSTALLED IN INTERNAL GROOVE)

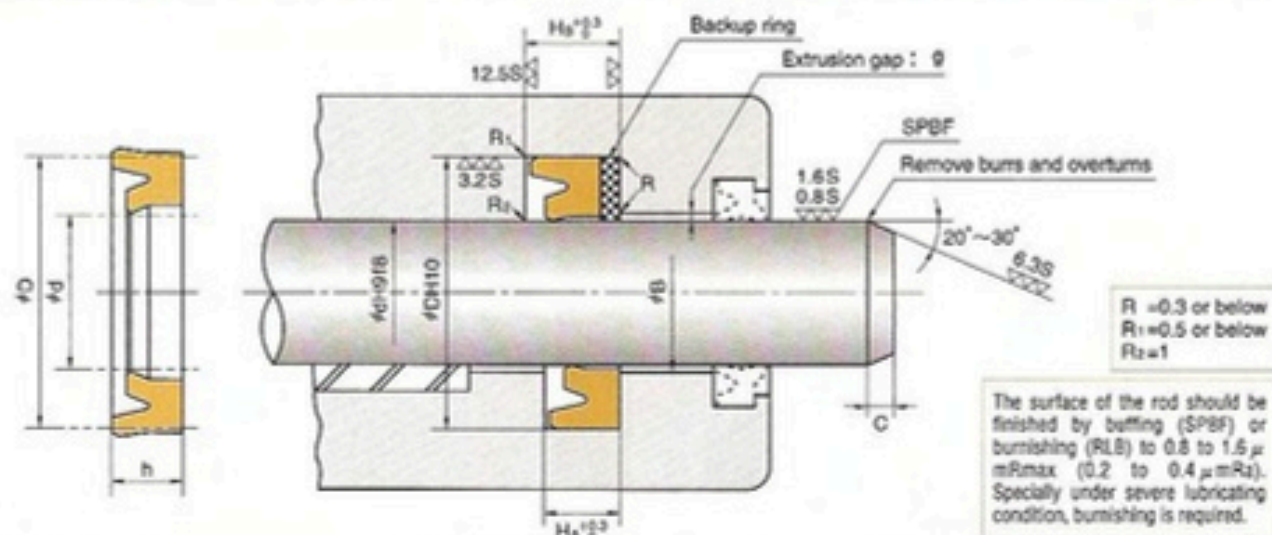

Nominal Size of Packing			Housing dimensions				NOK Part Number			
d	D	h	#d	#D	H _a	H _b	C	Standard (U801)	Heat resistant type (U641)	
18	26	5	18	26	5.7	7.7	2	FU0180K0	FU0180K2	
20	28	5	20	28				FU0212K0	FU0212K1	
22.4	30	5	22.4	30				FU0260K0	FU0260K1	
	30.4	5	22.4	30.4				FU0261K0	FU0261K1	
23.5	31.5	5	23.5	31.5				FU0267K0	FU0267K1	
25	33	5	25	33				FU0276K0	FU0276K2	
	35	5	25	35				FU0278K0	FU0278K2	
28	35.5	5	28	35.5				FU0320K0	FU0320K1	
	36	5	28	36				FU0321K0	FU0321K1	
30	40	6	30	40				FU0357K0	FU0357K3	
31.5	41.5	6	31.5	41.5	FU0382K0	FU0382K1				
35	45	6	35	45	7	10	FU0424K0	FU0424K7		
35.5	45	6	35.5	45			FU0451K0	FU0451K1		
	45.5	6	35.5	45.5			FU0452K0	FU0452K1		
40	50	6	40	50			FU0497K0	FU0497K5		
45	55	6	45	55			FU0567K0	FU0567K6		
	56	7	45	56			FU0572K0	FU0572K1		
50	60	6	50	60			7	10	FU0619K0	FU0619K3
	53	63	6	53					63	FU0679K0
55	65	6	55	65					FU0694K0	FU0694K2
56	66	6	56	66					FU0722K0	FU0722K1
60	70	6	60	70	FU0746K0	FU0746K5				
	71	7	60	71	FU0750K0	FU0750K1				
63	73	6	63	73	FU0786K0	FU0786K3				
65	75	6	65	75	FU0809K0	FU0809K1				
67	77	6	67	77	FU0828K0	FU0828K1				
70	80	6	70	80	FU0849K0	FU0849K5				
71	81	6	71	81	FU0880K0	FU0880K1				
75	85	6	75	85	FU0901K0	FU0901K1				
80	90	6	80	90	FU0939K0	FU0939K1				
85	100	9	85	100	10	13	FU0984K0	FU0984K2		
90	105	9	90	105			FU1024K0	FU1024K3		
95	110	9	95	110			FU1051K0	FU1051K2		
98	112	8.5	98	112			FU1067K0	FU1067K1		
100	115	9	100	115			FU1082K0	FU1082K1		
105	120	9	105	120			FU1125K0	FU1125K1		
106	120	8.5	106	120			9.5	12.5	FU1135K0	FU1135K1
	121	9	106	121			FU1136K0	FU1136K1		
110	125	9	110	125			10	13	FU1157K0	FU1157K2
112	125	9	112	125			FU1179K0	FU1179K1		

HOW TO DETERMINE B DIMENSION

■ When using backup ring

Please determine B dimension according to the table below. If you require larger B dimension because of the cylinder configuration, please consult NOK.

Maximum Service Pressure	14MPa	21MPa	35MPa
Material of Backup ring	19YF		
B Dimension	$B \leq \phi d + 1.0$	$B \leq \phi d + 0.5$	$B \leq \phi d + 0.2$
Maximum Service Pressure	35MPa	42MPa	
Material of Backup ring	80NP		
B Dimension	$B \leq \phi d + 0.8$	$B \leq \phi d + 0.4$	

■ When not using backup ring

To determine ϕB dimension, please refer to the graph in the right for the maximum extrusion gap (also refer page 26) considering the eccentricity of operating condition.

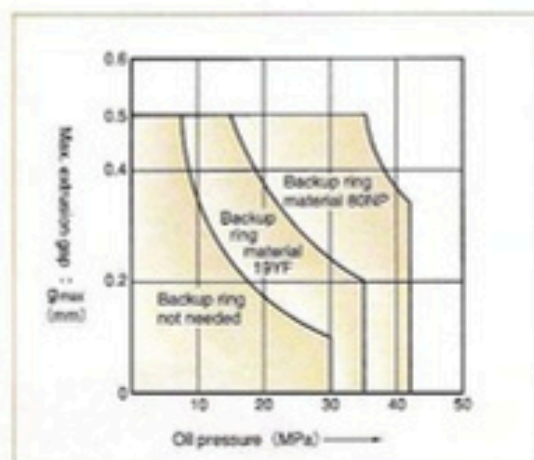

Nominal Size of			Housing dimensions				NOK Part Number			
d	D	h	ϕd	ϕD	H _A	H _B	C	Standard (U801)	Heat resistant type (U841)	
118	133	9	118	133	10	13	4	FU1205K0	FU1205K1	
120	135	9	120	135				FU1220K0	FU1220K1	
125	140	9	125	140				FU1252K0	FU1252K1	
130	145	9	130	145				FU1280K0	FU1280K1	
136	150	8.5	136	150	9.5	12.5		FU1306K0	FU1306K1	
140	155	9	140	155	10	13		FU1323K0	FU1323K2	
145	160	9	145	160				FU1343K0	FU1343K1	
150	165	9	150	165				FU1359K0	FU1359K1	
155	170	9	155	170				FU1388K0	FU1388K2	
160	175	9	160	175				FU1406K0	FU1406K1	
165	180	9	165	180				FU1429K0	FU1429K1	
170	185	9	170	185				FU1443K0	FU1443K2	
175	190	9	175	190				FU1459K0	FU1459K1	
180	200	12	180	200	13	17		FU1483K0	FU1483K1	
190	210	12	190	210				FU1516K0	FU1516K1	
200	220	12	200	220				FU1543K0	FU1543K1	
204	224	12	204	224			FU1563K0	FU1563K1		
210	230	12	210	230			FU1575K0	FU1575K1		
220	240	12	220	240			FU1596K0	FU1596K1		
225	245	12	225	245			FU1621K0	FU1621K1		
230	250	12	230	250			FU1637K0	FU1637K1		
240	260	12	240	260			FU1657K0	FU1657K1		
250	270	12	250	270			FU1678K0	FU1678K1		
260	285	16	260	285			17	21	FU1704K0	FU1704K1
270	295	16	270	295					FU1720K0	FU1720K1
280	305	16	280	305	FU1733K0	FU1733K1				
290	315	16	290	315	FU1748K0	FU1748K1				
300	325	16	300	325	FU1762K0	FU1762K1				
									6.5	

IUH TYPE

SPECIAL PACKINGS FOR ROD SEALS
NITRILE RUBBER (NBR)



- Please designate NOK Part number and type & size on your order.

(Example) • Type Dimensions IUH 20 28 5
 └───┬───┘
 Type Sign Nominal Size of Packing
 described in order of inner diameter(d), outer diameter(D), and height(h)

• Part Number CU0212N2

- Please check the application range on pages D-2 and 3 before selecting the type.

Material	Standard : NOK A505 Low temperature resistant type : NOK A903
-----------------	--

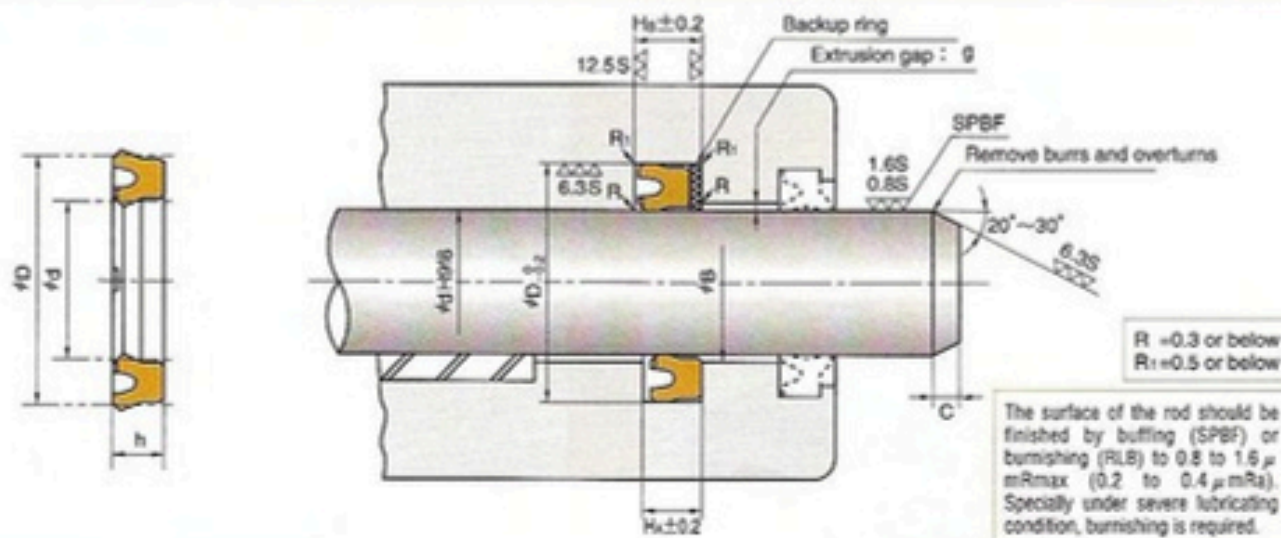

HOW TO DETERMINE B DIMENSION

■ When using backup ring

Please determine B dimension according to the table below. If you require larger B dimension because of the cylinder configuration, please consult NOK.

Maximum Service Pressure	14MPa	21MPa
Material of Backup ring	19YF	
B Dimension	$B \leq \phi d + 1.0$	$B \leq \phi d + 0.5$

■ When not using backup ring

To determine ϕB dimension, please refer to the graph in the right for the maximum extrusion gap (also refer page 26) considering the eccentricity of operating condition.

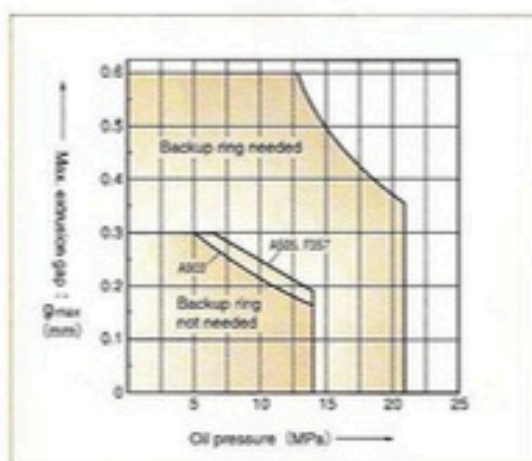

Nominal Size of Packing			Housing dimensions				NOK Part Number		
d	D	h	ϕd	ϕD	H_a	H_b	C	Standard (A505)	Low torque series (R03)
20	28	5	20	28	5.7	7.7	2.5	CU0212N2	CU0212N1
25	33		25	33				CU0276N2	CU0276N1
30	40		30	40				CU0357N2	CU0357N1
35	45	6	35	45	7	10	3	CU0424N2	CU0424N1
40	50		40	50				CU0497N2	CU0497N1
45	55		45	55				CU0567N2	CU0567N1
50	60		50	60				CU0619N2	CU0619N1
55	65		55	65				CU0694N2	CU0694N1
60	70		60	70				CU0746N2	CU0746N1
65	75	9	65	75	10	13	4	CU0809N2	CU0809N1
70	85		70	85				CU0857N2	CU0857N1
75	85		75	85				CU0901N2	CU0901N1
80	90	6	80	90	7	10	4	CU0939N2	CU0939N1
90	105		90	105				CU1024N2	CU1024N1
95	110		95	110				CU1051N1	
100	115	9	100	115	10	13	4	CU1082N2	CU1082N1
110	125		110	125				CU1157N1	CU1157N0
125	140		125	140				CU1252N2	CU1252N1
150	165		150	165				CU1359N1	CU1359N0

UNI_{TYPE}

SPECIAL PACKINGS FOR ROD SEALS
NOXLAN (AU) + SILICON RUBBER (VMQ)



- Please designate NOK Part number and type & size on your order.

(Example) • Type Dimensions

UNI 40 50 7

Type Sign

Nominal Size of Packing
described in order of inner diameter(d), outer diameter(D), and height(h)

• Part Number FU2002M1

- Please check the application range on pages D-2 and 3 before selecting the type.

Material	NOK U801 + NOK S813
-----------------	---------------------

UNI TYPE SPECIAL PACKINGS FOR ROD SEALS

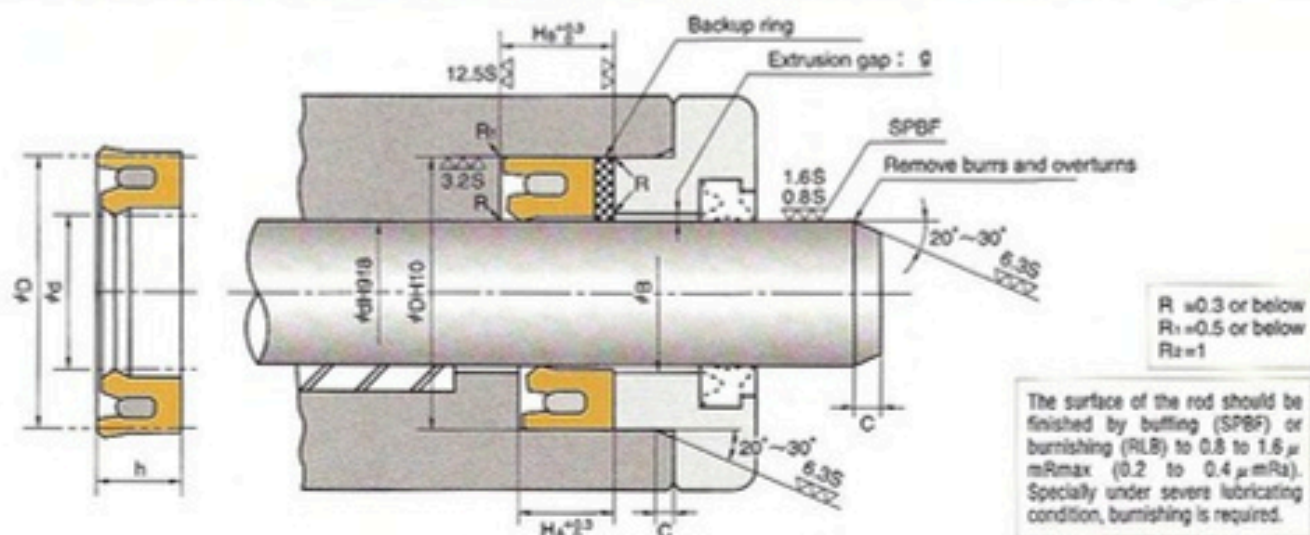

HOW TO DETERMINE B DIMENSION

When using backup ring

Please determine B dimension according to the table below. If you require larger B dimension because of the cylinder configuration, please consult NOK.

Maximum Service Pressure	14MPa	21MPa	35MPa
Material of Backup ring	19YF		
B Dimension	$B \leq \phi d + 1.0$	$B \leq \phi d + 0.5$	$B \leq \phi d + 0.2$

Maximum Service Pressure	35MPa	42MPa
Material of Backup ring	80NP	
B Dimension	$B \leq \phi d + 0.8$	$B \leq \phi d + 0.4$

When not using backup ring

To determine ϕB dimension, please refer to the graph in the right for the maximum extrusion gap (also refer page 26) considering the eccentricity of operating condition.

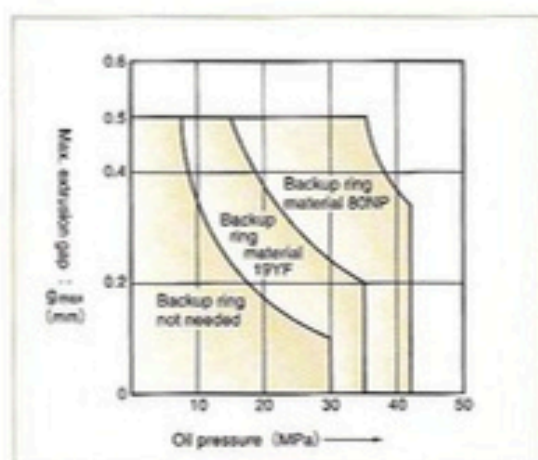

Nominal Size of Packing			Housing dimensions				NOK Part Number	
d	D	h	ϕd	ϕD	H_A	H_B		
40	50	7	40	50	8	11	4	FU2002M1
45	55		45	55				FU0568M1
50	63		50	63				FU1925M1
55	68		55	68				FU1995M1
60	73		60	73				FU2097M1
65	78	10	65	78	11	14	5	FU2074M1
70	83		70	83				FU2088M1
75	88		75	88				FU2227M1
80	93		80	93				FU2107M1
85	105		85	105				FU0990M1
90	110	15	90	110	16	19	6.5	FU1031M1
100	120		100	120				FU1091M1
110	130		110	130				FU1165M1
120	140		120	140				FU1224M1
130	150		130	150				FU1285M1
140	165	19	140	165	20	23		FU1332M1

F

SPNO TYPE SPECIAL PACKINGS FOR ROD SEALS

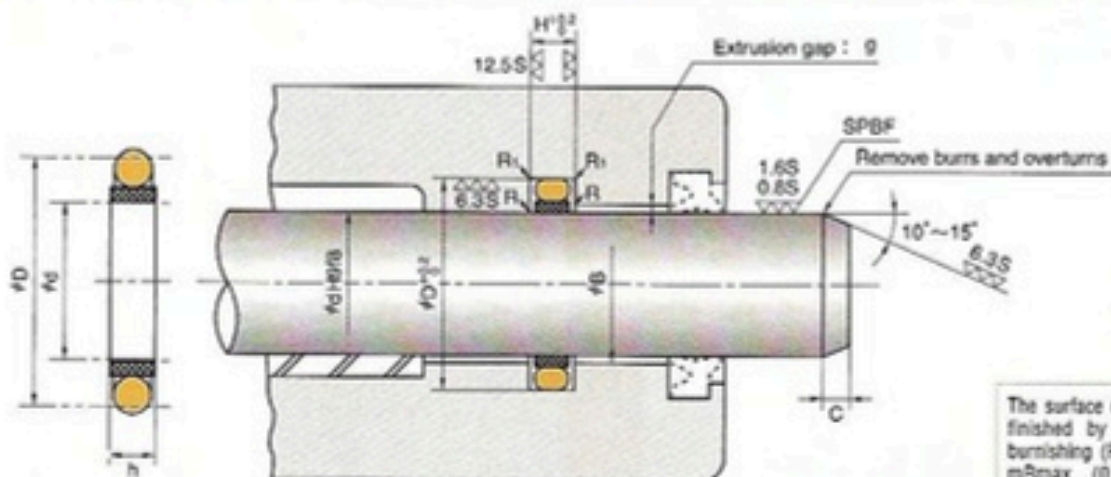

Nominal Number	Nominal Size of Packing			Housing dimensions				NOK Part Number
	d	D	h	ϕd	ϕD	H	C	
SPNO 12	12	18	3	12	18	3.2	2	● GS2800V0
14	14	20		14	20			● GS2801V0
16	16	22		16	22			● GS2802V0
18	18	24		18	24			● GS2803V0
20	20	26		20	26			● GS2804V0
22	22	31	3.8	22	31	4	3.5	● GS2805V0
25	25	34		25	34			● GS2806V0
28	28	37		28	37			● GS2807V0
30	30	39		30	39			● GS2808V0
32	32	41		32	41			● GS2809V0
36	36	45		36	45			● GS2810V0
40	40	49		40	49			● GS2811V0
45	45	54		45	54			● GS2812V0
50	50	65		50	65			● GS2813V0
56	56	71		56	71			GS2814V0
60	60	75	6.3	60	75	6.5	4	GS2815V0
63	63	78		63	78			GS2816V0
70	70	85		70	85			GS2817V0
75	75	90		75	90			GS2818V0
80	80	95		80	95			GS2819V0
85	85	100		85	100		GS2820V0	
90	90	105		90	105		GS2821V0	
95	95	110		95	110		GS2822V0	
100	100	115		100	115		GS2823V0	
105	105	120		105	120		GS2824V0	
110	110	125	110	125	GS2825V0			

Remarks: When using the packing with ●, provide separate grooves.

HOW TO DETERMINE B DIMENSION

To determine ϕB dimension, please refer to the graph in the right for the maximum extrusion gap (also refer page 26) considering the eccentricity of operating condition.

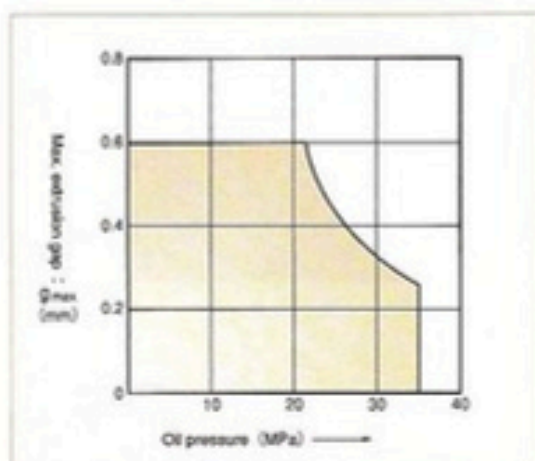

Nominal Number	Nominal Size of Packing			Housing dimensions				NOK Part Number
	d	D	h	ϕd	ϕD	H	C	
SPNO 115	115	130	6.3	115	130	6.5	6.5	GS2826V0
120	120	135		120	135			GS2827V0
125	125	140		125	140			GS2828V0
130	130	145		130	145			GS2829V0
135	135	150		135	150			GS2830V0
140	140	155		140	155			GS2831V0
145	145	160		145	160			GS2832V0
150	150	170		150	170			GS2833V0
160	160	180		160	180			GS2834V0
170	170	190		170	190			GS2835V0
180	180	200	9.8	180	200	10	6.5	GS2836V0
190	190	210		190	210			GS2837V0
200	200	220		200	220			GS2838V0
210	210	230		210	230			GS2839V0
220	220	240		220	240			GS2840V0
224	224	244		224	244			GS2841V0
230	230	250		230	250			GS2842V0
240	240	260		240	260			GS2843V0
250	250	270		250	270			GS2844V0
260	260	280		260	280			GS2845V0
270	270	290		270	290		GS2846V0	
280	280	300		280	300		GS2847V0	
290	290	310		290	310		GS2848V0	
300	300	320		300	320		GS2849V0	
310	310	330		310	330		GS2850V0	
320	320	340		320	340		GS2851V0	
330	330	350		330	350		GS2852V0	
340	340	360		340	360		GS2853V0	
350	350	370		350	370		GS2854V0	
360	360	380		360	380		GS2855V0	
370	370	390	370	390	GS2856V0			
380	380	400	380	400	GS2857V0			

SPN_{TYPE}

SPECIAL PACKINGS FOR ROD SEALS
RAREFLON (PTFE) + NITRILE RUBBER (NBR)



F

- Please designate NOK Part number and type & size on your order.

(Example) • Type Dimensions SPN 18 27 4.3

└─ Type Sign

└─ Nominal Size of Packing
described in order of inner diameter(d), outer diameter(D), and height(h)

• Part Number GS2301V0

- Please check the application range on pages D-2 and 3 before selecting the type.

Material	NOK 19YF + NOK A980
-----------------	---------------------

SPN_{TYPE} SPECIAL PACKINGS FOR ROD SEALS

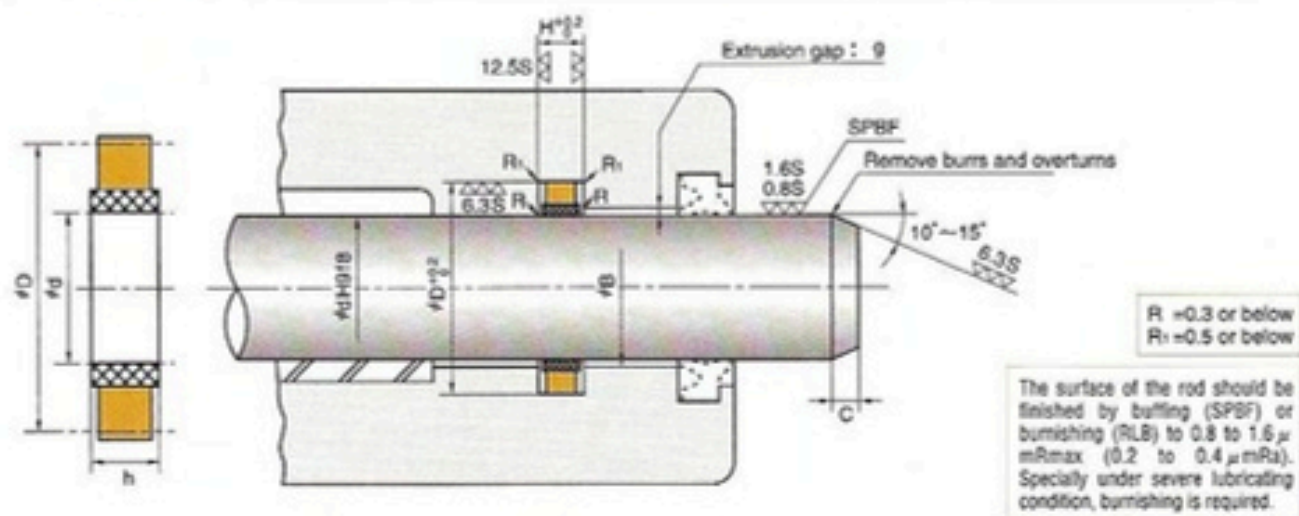

HOW TO DETERMINE B DIMENSION

To determine ϕB dimension, please refer to the graph in the right for the maximum extrusion gap (also refer page 26) considering the eccentricity of operating condition.

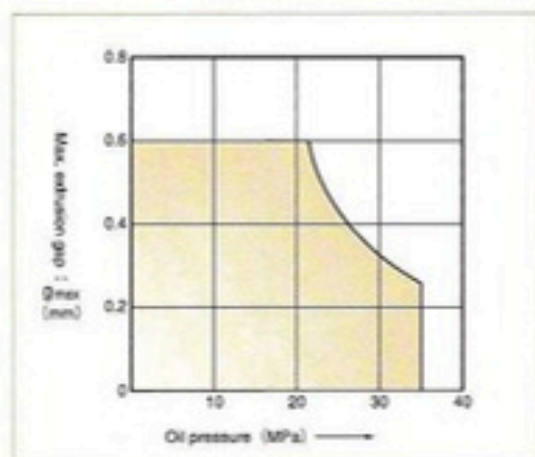

Nominal Number	Nominal Size of Packing			Housing dimensions				NOK Part Number
	d	D	h	ϕd	ϕD	H	C	
SPN 18	18	27	4.3	18	27	4.5	3.5	● GS2301V0
20	20	29		20	29			● GS2302V0
22	22	31		22	31			● GS2303V0
27	27	36		27	36			● GS2304V0
31.5	31.5	40.5		31.5	40.5			● GS2305V0
47	47	60	7.3	47	60	7.5	4	● GS2306V0
53	53	66		53	66			GS2307V0
60	60	73		60	73		GS2308V0	
65	65	78		65	78		GS2309V0	
70	70	83		70	83		GS2310V0	
75	75	88		75	88		GS2311V0	
80	80	93		80	93		GS2312V0	
90	90	103.4		90	103.4		GS2313V0	
100	100	113.4		100	113.4		GS2314V0	
105	105	118.4		105	118.4		GS2315V0	
110	110	123.4		110	123.4		GS2316V0	
120	120	133.4		120	133.4		GS2317V0	
130	130	143.4	140	130	143.4	6.5	GS2318V0	
140	140	153.4		140	153.4		GS2319V0	

Remarks: When using the packing with ●, provide separate grooves.

SPNC_{TYPE}

SPECIAL PACKINGS FOR ROD SEALS
RAREFLON (PTFE) + NITRILE RUBBER (NBR)



- Please designate NOK Part number and type & size on your order.

(Example) • Type Dimensions SPNC 3 6 2.3

Type Sign

Nominal Size of Packing
described in order of inner diameter(d), outer diameter(D), and height(h)

• Part Number GS2000F0

- Please check the application range on pages D-2 and 3 before selecting the type.

Material	NOK 31BF + NOK A305
----------	---------------------

SPNC_{TYPE} SPECIAL PACKINGS FOR ROD SEALS

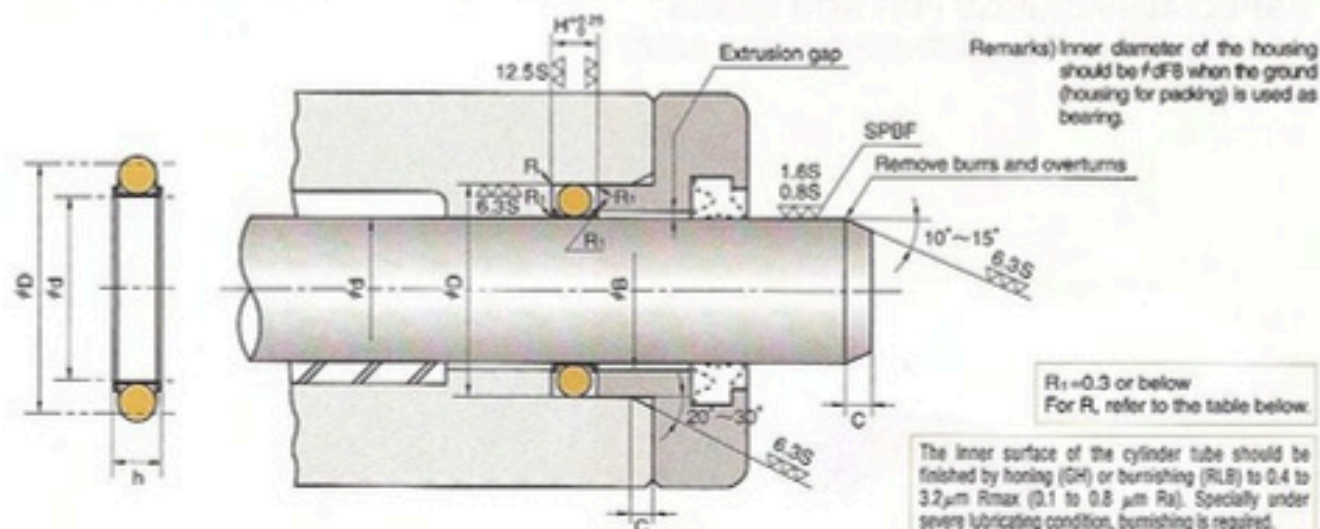

Nominal Number	Nominal Size of Packing			Housing dimensions								NOK Part Number
				For general hydraulic use				For pneumatic and hydraulic low-friction applications				
	d	D	h	φd	φD	φd	φD	H	R	C		
SPNC 3	3	6	2.3	3	6	3	6.5	2.5	0.3以下	3~4	GS2000F0	
4	4	7		4	7	4	7.5				GS2001F0	
5	5	8		5	8	5	8.5				GS2002F0	
6	6	9		6	9	6	9.5				GS2003F0	
7	7	10		7	10	7	10.5				GS2004F0	
8	8	11		8	11	8	11.5				GS2005F0	
9	9	12		9	12	9	12.5				GS2006F0	
10	10	13		10	13	10	13.5				GS2007F0	
10A	10	14		10	14	10	14.6				GS2008F0	
11	11	15		11	15	11	15.6				GS2009F0	
11.2	11.2	15.2	11.2	15.2	11.2	15.8	GS2010F0					
12	12	16	3	12	16	12	16.6	3.2	0.4以下	4~5	GS2011F0	
12.5	12.5	16.5		12.5	16.5	12.5	17.1				GS2012F0	
14	14	18		14	18	14	18.6				GS2013F0	
15	15	19		15	19	15	19.6				GS2014F0	
16	16	20		16	20	16	20.6				GS2015F0	
18	18	22		18	22	18	22.6				GS2016F0	
20	20	24		20	24	20	24.6				GS2017F0	
21	21	25		21	25	21	25.6				GS2018F0	
22	22	26		22	26	22	26.6				GS2020F0	
22A	22	28		22	28	22	28.6				GS2019F0	
22.4	22.4	28.4	22.4	28.4	22.4	29	GS2021F0					
24	24	30	4.4	24	30	24	30.6	4.7	0.7以下	5~6	GS2022F0	
25	25	31		25	31	25	31.6				GS2023F0	
25.5	25.5	31.5		25.5	31.5	25.5	32.1				GS2024F0	
26	26	32		26	32	26	32.6				GS2025F0	
28	28	34		28	34	28	34.6				GS2026F0	
29	29	35		29	35	29	35.6				GS2027F0	
29.5	29.5	35.5		29.5	35.5	29.5	36.1				GS2028F0	
30	30	36		30	36	30	36.6				GS2029F0	
31	31	37		31	37	31	37.6				GS2030F0	
31.5	31.5	37.5		31.5	37.5	31.5	38.1				GS2031F0	
32	32	38	32	38	32	38.6	GS2032F0					
34	34	40	34	40	34	40.6	GS2033F0					
35	35	41	35	41	35	41.6	GS2034F0					
35.5	35.5	41.5	35.5	41.5	35.5	42.1	GS2035F0					
36	36	42	36	42	36	42.6	GS2036F0					
38	38	44	38	44	38	44.6	GS2037F0					
39	39	45	39	45	39	45.6	GS2038F0					
40	40	46	40	46	40	46.6	GS2039F0					

HOW TO DETERMINE B DIMENSION

To determine ϕB dimension, please make the maximum extrusion gap (also refer page 26) 0.4mm or below considering the eccentricity of operating condition.

Nominal Number	Nominal Size of Packing			Housing dimensions								NOK Part Number
				For general hydraulic use				For pneumatic and hydraulic low-friction applications				
	d	D	h	ϕd	ϕD	ϕd	ϕD	H	R	C		
SPNC 41	41	47	4.4	41	47	41	47.6	4.7	0.7以下	5~6	GS2040F0	
42	42	48		42	48	42	48.6				GS2041F0	
44	44	50		44	50	44	50.6				GS2042F0	
45	45	51		45	51	45	51.6				GS2043F0	
46	46	52		46	52	46	52.6				GS2044F0	
48	48	54		48	54	48	54.6				GS2046F0	
49	49	55		49	55	49	55.6				GS2047F0	
50	50	56		50	56	50	56.6				GS2049F0	
48A	48	58		48	58	48	58.6				GS2045F0	
50A	50	60		50	60	50	60.6				GS2048F0	
52	52	62	7.0	52	62	52	62.6	7.5	0.8以下	6~8	GS2050F0	
53	53	63		53	63	53	63.6				GS2051F0	
55	55	65		55	65	55	65.6				GS2052F0	
56	56	66		56	66	56	66.6				GS2053F0	
58	58	68		58	68	58	68.6				GS2054F0	
60	60	70		60	70	60	70.6				GS2055F0	
62	62	72		62	72	62	72.6				GS2056F0	
63	63	73		63	73	63	73.6				GS2057F0	
65	65	75		65	75	65	75.6				GS2058F0	
67	67	77		67	77	67	77.6				GS2059F0	
70	70	80		70	80	70	80.6				GS2060F0	
71	71	81		71	81	71	81.6				GS2061F0	
75	75	85		75	85	75	85.6				GS2062F0	
80	80	90		80	90	80	90.6				GS2063F0	
85	85	95		85	95	85	95.6				GS2064F0	
90	90	100		90	100	90	100.6				GS2065F0	
95	95	105		95	105	95	105.6				GS2066F0	
100	100	110		100	110	100	110.6				GS2067F0	
102	102	112		102	112	102	112.6				GS2068F0	
105	105	115		105	115	105	115.6				GS2069F0	
110	110	120	110	120	110	120.6	GS2070F0					
112	112	122	112	122	112	122.6	GS2071F0					
115	115	125	115	125	115	125.6	GS2072F0					
120	120	130	120	130	120	130.6	GS2073F0					
125	125	135	125	135	125	135.6	GS2074F0					
130	130	140	130	140	130	140.6	GS2075F0					
132	132	142	132	142	132	142.6	GS2076F0					
135	135	145	135	145	135	145.6	GS2077F0					
140	140	150	140	150	140	150.6	GS2078F0					
145	145	155	145	155	145	155.6	GS2079F0					
150	150	160	150	160	150	160.6	GS2081F0					

SPNC_{TYPE} SPECIAL PACKINGS FOR ROD SEALS

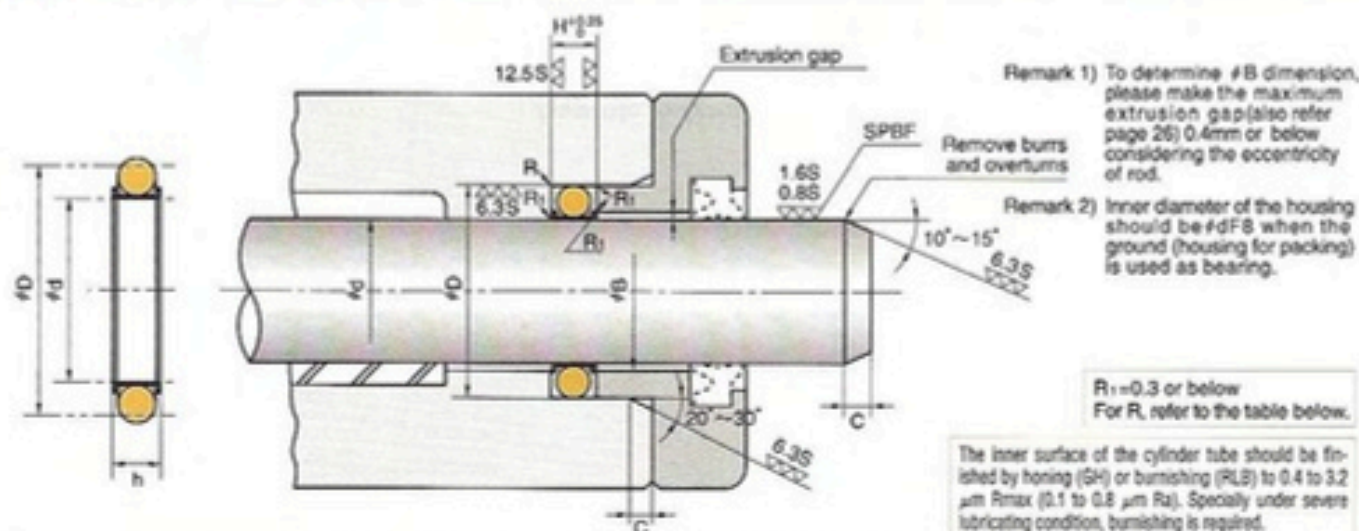

Nominal Number	Nominal Size of Packing			Housing dimensions				H	R	C	NOK Part Number	
				For general hydraulic use		For pneumatic and hydraulic low-friction applications						
	d	D	h	#d	#D	#d	#D					
SPNC 150A	150	165		150	165	150	165.6				GS2080F0	
155	155	170		155	170	155	170.6				GS2082F0	
160	160	175		160	175	160	175.6				GS2083F0	
165	165	180		165	180	165	180.6				GS2084F0	
170	170	185		170	185	170	185.6				GS2085F0	
175	175	190		175	190	175	190.6				GS2086F0	
180	180	195		180	195	180	195.6				GS2087F0	
185	185	200		185	200	185	200.6				GS2088F0	
190	190	205		190	205	190	205.6				GS2089F0	
195	195	210		195	210	195	210.6				GS2090F0	
200	200	215		200	215	200	215.6				GS2091F0	
205	205	220		205	220	205	220.6				GS2092F0	
209	209	224		209	224	209	224.6				GS2093F0	
210	210	225		210	225	210	225.6				GS2094F0	
215	215	230		215	230	215	230.6				GS2095F0	
220	220	235		220	235	220	235.6				GS2096F0	
225	225	240		225	240	225	240.6				GS2097F0	
230	230	245		230	245	230	245.6				GS2098F0	
235	235	250		235	250	235	250.6				GS2099F0	
240	240	255	10.5	240	255	240	255.6	±0.1	11.0	0.8 or below	8~12	GS2100F0
245	245	260		245	260	245	260.6					GS2101F0
250	250	265		250	265	250	265.6					GS2102F0
255	255	270		255	270	255	270.6					GS2103F0
260	260	275		260	275	260	275.6					GS2104F0
265	265	280		265	280	265	280.6					GS2105F0
270	270	285		270	285	270	285.6					GS2106F0
275	275	290		275	290	275	290.6					GS2107F0
280	280	295		280	295	280	295.6					GS2108F0
285	285	300		285	300	285	300.6					GS2109F0
290	290	305		290	305	290	305.6					GS2110F0
295	295	310		295	310	295	310.6					GS2111F0
300	300	315		300	315	300	315.6					GS2112F0
315	315	330		315	330	315	330.6					GS2113F0
320	320	335		320	335	320	335.6					GS2114F0
335	335	350		335	350	335	350.6					GS2115F0
340	340	355		340	355	340	355.6					GS2116F0
355	355	370		355	370	355	370.6					GS2117F0
360	360	375		360	375	360	375.6					GS2118F0
375	375	390		375	390	375	390.6					GS2119F0
385	385	400		385	400	385	400.6					GS2120F0

UPI_{TYPE}

PACKINGS FOR BOTH PISTON AND ROD SEALS
NOXLAN (AU)



- Please designate NOK Part number and type & size on your order.

(Example) • Type Dimensions

UPI 6.3 16.3 8

Type Sign

Nominal Size of Packing
described in order of inner diameter(d), outer diameter(D), and height(h)

• Part Number

FU0024D0

- Please check the application * D-2 and 3 before selecting the type.

Material	NOK U801
-----------------	----------

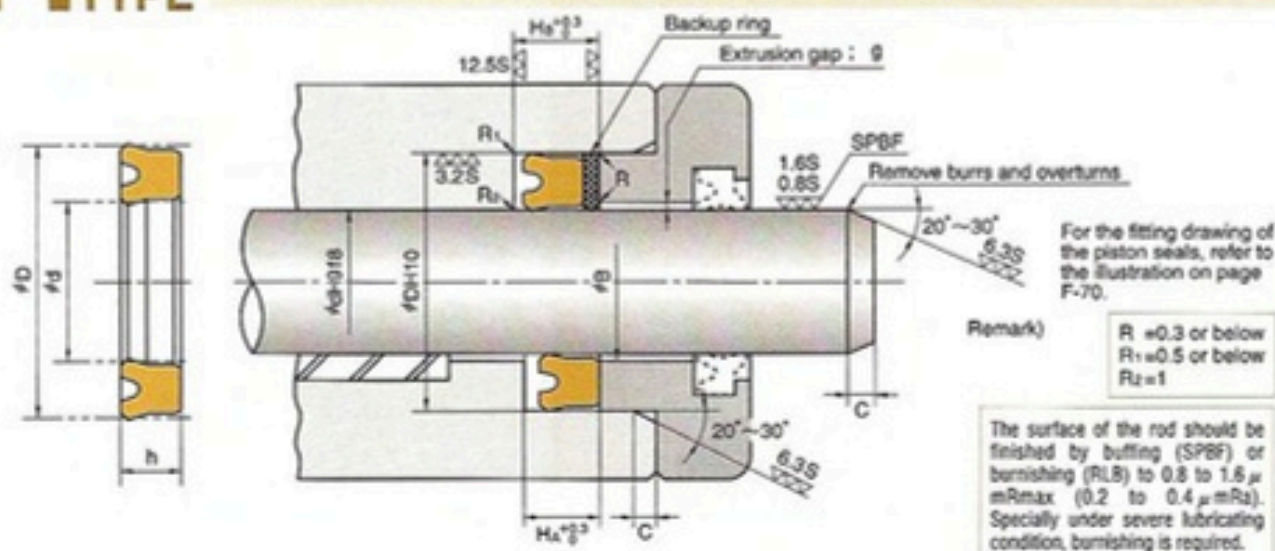

Nominal Size of Packing			Housing dimensions						NOK
d	D	h	#d	#D	#D ₁	H _A	H _B	C	Part Number
6.3	16.3	8	6.3	16.3	15.3	9	11	2.5	FU0024D0
7.1	17.1	8	7.1	17.1	16.1				FU0030D0
8	18	8	8	18	17				FU0043D0
9	19	8	9	19	18				FU0054D0
10	20	8	10	20	19				FU0069D0
11.2	21.2	8	11.2	21.2	20.2				FU0081D0
12	25	8	12	25	24				FU0093D0
12.5	22.5	8	12.5	22.5	21.5				FU0102D0
14	24	8	14	24	23				FU0122D0
15	25	8	15	25	24				FU0135D0
16	26	8	16	26	25				FU0157D0
	32	10	16	32	31				11
18	28	8	18	28	27	9	11	FU0182D0	
	31	10	18	31	30	11	13	FU0186D0	
20	30	8	20	30	29	9	11	FU0215D0	
	33	10	20	33	32	11	13	FU0221D0	
	35	10	20	35	34			FU0224D0	
21.5	31.5	8	21.5	31.5	30.5	9	11	FU0239D0	
22	32	8	22	32	31	11	13	FU0246D0	
	35	10	22	35	34			FU0249D0	
22.4	30	5	22.4	30	29	5.7	7.7	FU0260D0	
	32.4	8	22.4	32.4	31.4			FU0263D0	
25	35	8	25	35	34	9	11	FU0282D0	
	38	8	25	38	37			FU0287D0	
	40	10	25	40	39	11	13	FU0292D0	
	45	12	25	45	44	13	15	FU0301D0	
25.5	35.5	8	25.5	35.5	34.5	9	11	FU0309D1	
28	35.5	5	28	35.5	34.5	5.7	8.7	FU0320D1	
	40	10	28	40	39			FU0330D0	
	43	10	28	43	42			FU0340D0	
30	45	10	30	45	44	11	14	FU0368D0	
	46	10	30	46	45			FU0369D0	
31.5	46.5	10	31.5	46.5	45.5			FU0387D0	
32	46	10	32	46	45			FU0403D0	
35	50	10	35	50	49			FU0437D0	
35.5	45	6	35.5	45	44			7	10
	50.5	10	35.5	50.5	49.5			FU0456D0	
38	52	10	38	52	51	11	14	FU0470D0	
40	55	10	40	55	54			FU0505D0	
	56	10	40	56	55			FU0508D0	
	60	12	40	60	59			13	16
41	56	10	41	56	55	11	14	FU0523D0	

HOW TO DETERMINE B DIMENSION

■ When using backup ring

Please determine B dimension according to the table below. If you require smaller B dimension (in case of piston seals) or larger B dimension (in case of rod seals) because of the cylinder configuration, please consult NOK.

Maximum Service Pressure		14MPa	21MPa	35MPa	35MPa
Material of Backup ring		19YF			80NP
Dimension	For rod	$B \leq \phi d + 1.0$	$B \leq \phi d + 0.5$	$B \leq \phi d + 0.2$	$B \leq \phi d + 0.8$
	For piston	$B \geq \phi D - 1.0$	$B \geq \phi D - 0.5$	$B \geq \phi D - 0.2$	$B \geq \phi D - 0.8$

■ When not using backup ring

To determine ϕB dimension, please refer to the graph in the right for the maximum extrusion gap (also refer page 26) considering the eccentricity of operating condition.

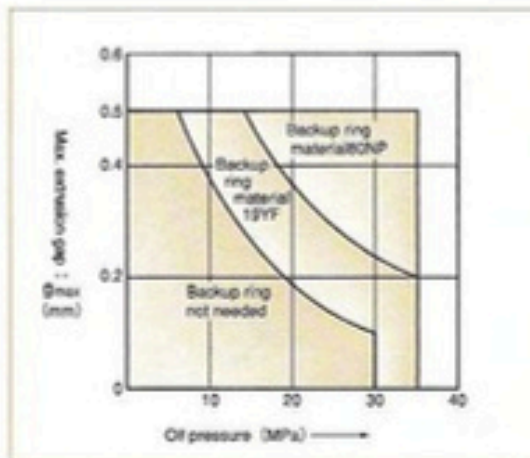

Nominal Size of Packing			Housing dimensions					C	NOK Part Number		
d	D	h	ϕd	ϕD	ϕD_1	H _k	H _b				
45	56	7	45	56	55	8	11	4	FU0572D1		
	60	10	45	60	59				11	14	FU0577D0
	61	10	45	61	60						FU0579D0
46	60	10	46	60	59	13	16		FU0588D0		
48	63	10	48	63	62				FU0601D0		
50	65	10	50	65	64				16	19	FU0631D0
	66	12	50	66	65	FU0635D0					
	70	12	50	70	69	FU0639D0					
51	71	12	51	71	70	13	16		FU0669D0		
53	73	12	53	73	72			FU0683D0			
55	71	12	55	71	70			16	19	FU0704D0	
	75	12	55	75	74	FU0708D0					
	80	15	55	80	79	FU0712D0					
56	72	12	56	72	71	13	16	FU0727D0			
	76	12	56	76	75			FU0728D0			
58	78	12	58	78	77	8	11	FU0736D0			
60	71	7	60	71	70			13	16	FU0750D0	
	80	12	60	80	79					FU0761D0	
62	82	12	62	82	81	13	16	FU0777D0			
63	83	12	63	83	82			FU0793D0			
65	85	12	65	85	84			FU0819D0			
67	87	12	67	87	86	7	10	FU0831D0			
70	90	12	70	90	89			FU0862D0			
71	80	6	71	80	79			13	16	FU0879D1	
	91	12	71	91	90	FU0884D0					
75	95	12	75	95	94	16	19	FU0910D0			
80	100	12	80	100	98			10	13	FU0948D0	
	100	15	80	100	98					FU0949D0	
85	100	9	85	100	98	13	16	FU0984D1			
	105	12	85	105	103			FU0989D0			
90	110	12	90	110	108	16	19	FU1030D0			
92	112	12	92	112	110			FU1042D0			
95	115	12	95	115	113			10	13	FU1056D0	
	120	15	95	120	118	FU1061D0					
98	112	9	98	112	110	13	16	FU1068D0			
	120	12	100	120	118			FU1089D0			
100	125	15	100	125	123	17	20	FU1096D0			
105	125	15	105	125	123			FU1129D0			
106	120	8.5	106	120	118			9.5	12.5	FU1135D1	
	126	15	106	126	124	FU1138D0					
110	130	15	110	130	128	17	20	FU1165D0			
112	132	15	112	132	130			FU1182D0			

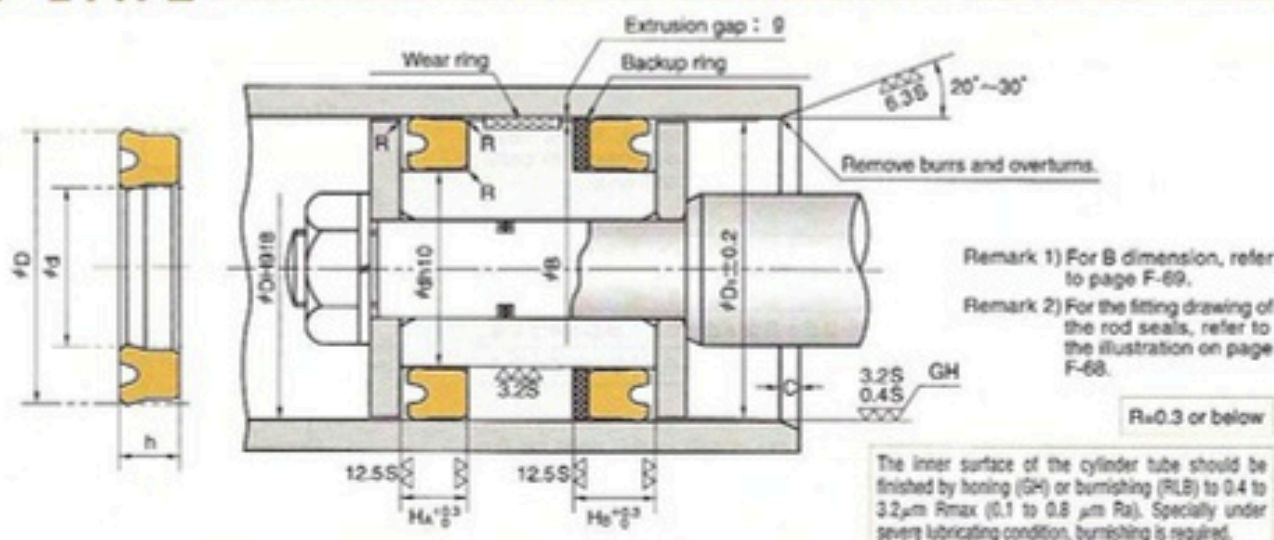

Nominal Size of Packing			Housing dimensions						NOK Part Number		
d	D	h	ϕd	ϕD	ϕD_1	H_A	H_B	C			
115	135	15	115	135	133	17	20	5	FU1198D0		
118	132	9	118	132	130	10	13		FU1932D0		
	138	15	118	138	136				FU1207D0		
120	140	15	120	140	138				17	20	FU1224D0
125	145	15	125	145	143						FU1257D0
130	150	15	130	150	148						FU1284D0
132	152	15	132	152	150						FU1292D0
135	155	15	135	155	153						FU1305D0
136	150	9	136	150	148						10
140	160	15	140	160	158				17	20	
	165	15	140	165	163			FU1330D0			
145	165	15	145	165	163	FU1344D0					
150	170	15	150	170	168	17	21	FU1363D0			
	175	15	150	175	173			FU1365D0			
155	180	15	155	180	178			FU1391D0			
160	185	15	160	185	183			FU1413D0			
165	190	15	165	190	188			FU1431D0			
170	195	15	170	195	193			FU1448D0			
175	200	15	175	200	198			FU1461D0			
180	205	15	180	205	203			20	24	FU1490D0	
185	210	15	185	210	208					FU1504D0	
190	215	15	190	215	213					FU1519D0	
199	224	15	199	224	222	FU1532D0					
200	225	15	200	225	223	20	24			FU1547D0	
	225	18	200	225	223					FU1549D0	
205	235	18	205	235	233					FU1565D0	
210	235	18	210	235	233					FU1579D0	
212	237	18	212	237	235					FU1584D0	
220	245	18	220	245	243					FU1599D0	
224	249	18	224	249	247			FU1612D0			
225	250	18	225	250	248			FU1625D0			
230	254	18	230	254	252			20	24	FU1639D0	
	255	18	230	255	253					FU1641D0	
236	261	18	236	261	259	FU1648D0					
240	265	18	240	265	263	FU1662D0					
250	275	18	250	275	273	FU1682D0					
260	290	18	260	290	288	8	FU1706D0				
265	295	18	265	295	293		FU1713D0				
270	300	18	270	300	298		FU1722D0				
280	310	18	280	310	308		FU1735D0				
290	320	18	290	320	318		FU1750D0				
300	330	18	300	330	328		FU1764D0				

UPI TYPE PACKINGS FOR BOTH PISTON AND ROD SEALS Large size dimension table

■ When using packings on this large size dimension table, please consult NOK.

Nominal Size of Packing			Housing dimensions					C	NOK Part Number	
d	D	h	φd	φD	φD ₁	H ₁	H ₂			
310	340	22	310	340	338	24	28	10	FU1773D0	
315	345	22	315	345	343	24	28		FU1775D0	
320	350	15	320	350	348	17	21		FU1778D0	
	350	18	320	350	348	20	24		FU1779D0	
	350	22	320	350	348	24	28		FU1780D0	
	360	25	320	360	358	27	31		FU1781D0	
323	355	24	323	355	353	26	30		FU1784D0	
330	360	20	330	360	358	22	26		FU1788D0	
	360	22	330	360	358	24	28		FU1789D0	
	370	28	330	370	368	30	34		FU1791D0	
340	370	22	340	370	368	24	28		FU1795D0	
350	380	22	350	380	378		30		34	FU1799D0
	390	28	350	390	388	34			FU2016D0	
355	385	22	355	385	383	24	28		FU1801D0	
370	400	22	370	400	398				FU1809D0	
375	405	22	375	405	403				FU1812D0	
380	410	22	380	410	408				FU1816D0	
385	415	22	385	415	413				FU1993D0	
390	420	22	390	420	418				FU1818D0	
400	425	22	400	425	423				FU1822D0	
	430	22	400	430	428			FU1823D0		
405	440	25	405	440	438			27	32	FU1827D0
410	445	25	410	445	443					37
	460	35	410	460	458	FU1830D0				
415	450	25	415	450	448	27	32	FU1831D0		
420	455	25	420	455	453			FU1833D0		
425	460	25	425	460	458			FU2223D0		
430	460	22	430	460	458	24	29	FU1977D0		
	465	25	430	465	463	27	32	FU2013D0		
431	457.2	18	431	457.2	455	20	25	FU1839D0		
435	470	25	435	470	468	27	32	FU1841D0		
440	470	19	440	470	468	21	26	FU1842D0		
440	475	28	440	475	473	30	35	FU1976D0		
445	480	25	445	480	478	27	32	FU2428D0		
450	485	25	450	485	483	27	32	FU1845D0		

F

**UPI TYPE
PACKINGS FOR BOTH PISTON AND ROD SEALS**
Large size dimension table

■ When using packings on this large size dimension table, please consult NOK.

Nominal Size of Packing			Housing dimensions					C	NOK Part Number
d	D	h	φd	φD	φD ₁	H _a	H _b		
456	490	30	456	490	488	32	37	15	FU1847D1
460	495	25	460	495	493	27	32		FU1849D0
465	500	26.5	465	500	498	28.5	33.5		FU2648D0
470	505	25	470	505	503	27	32		FU1851D0
475	510	25	475	510	508				FU1854D0
480	515	25	480	515	513				FU2025D0
490	530	25	490	530	528				FU1855D0
500	535	25	500	535	533	30	35		FU1856D0
	540	25	500	540	538				FU1857D0
507	547	28	507	547	545	30	35		FU1858D0
525	565	28	525	565	563	27	32		FU2743D0
530	570	25	530	570	568	27	32		FU2718D0
540	575	23	540	575	573	25	30		FU2376D0
560	600	28	560	600	598	30	35		FU1865D0
595	640	28	595	640	638			FU1986D0	
600	650	32	600	650	648	34	39	FU2017D0	
650	690	25	650	690	688	27	32	FU2003D0	
660	700	32	660	700	698	34	39	FU1870D0	
680	720	32	680	720	718			FU1871D0	
695	745	32	695	745	743			FU2398D0	
700	750	35	700	750	748			37	42
730	750	30	730	750	748	32	37	FU2078D0	
755	800	32	755	800	798	34	39	FU1876D0	
800	830	20	800	830	828	22	27	FU1978D0	
	850	35	800	850	848	37	42	FU1881D0	
850	900	35	850	900	898			FU2219D0	
870	900	20	870	900	898	22	27	FU1979D0	
920	970	35	920	970	968	37	42	FU1888D1	
1050	1100	30	1050	1100	1098	32	37	FU2391D0	
1096	1146	30	1096	1146	1144			FU2558D0	
1150	1200	30	1150	1200	1198			FU2229D0	
1380	1430	30	1380	1430	1428			FU2392D0	

USI TYPE

PACKINGS FOR BOTH PISTON AND ROD SEALS
NOXLAN (AU)



- Please designate NOK Part number and type & size on your order.

(Example) • Type Dimensions

USI 10 18 5

Type Sign

Nominal Size of Packing
described in order of inner diameter(d), outer diameter(D), and height(h)

• Part Number FU0064S0

- Please check the application range on pages D-2 and 3 before selecting the type.

Material	NOK U593
----------	----------

USI TYPE PACKINGS FOR BOTH PISTON AND ROD SEALS (INSTALLED IN INTERNAL GROOVE)

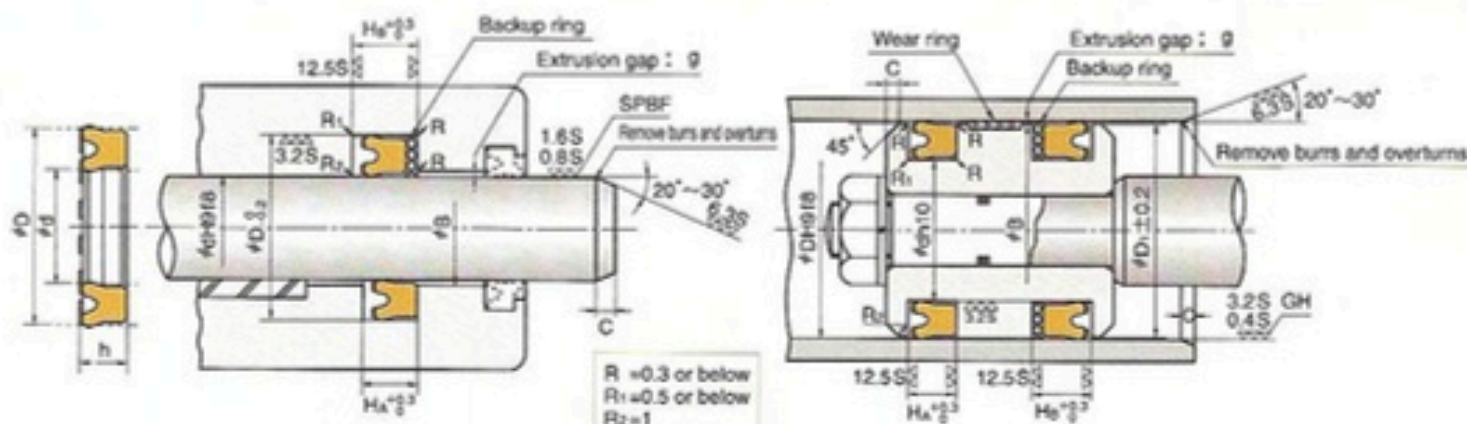

The surface of the rod should be finished by buffing (SPBF) or burnishing (RLB) to 0.8 to 1.6 μm Rmax (0.2 to 0.4 μm Ra). Specially under severe lubricating condition, burnishing is required.

The inner surface of the cylinder tube should be finished by honing (GH) or burnishing (RLB) to 0.4 to 3.2 μm Rmax (0.1 to 0.8 μm Ra). Specially under severe lubricating condition, burnishing is required.

Nominal Size of Packing			Housing dimensions						NOK Part Number	
d	D	h	#d	#D	#D ₁	H _k	H _b	C		
10	18	5	10	18	17	5.7	7.7	2	● FU0064S0	
12	20	5	12	20	19				○ FU0116S0	
12.5	20	5	12.5	20	19				○ FU0150S0	
14	22	5	14	22	21				○ FU2466S0	
16	24	5	16	24	23				○ FU0180S0	
17	25	5	17	25	24				○ FU0212S0	
18	26	5	18	26	25				○ FU0214S0	
20	28	5	20	28	27				○ FU2467S0	
	30	6	20	30	29	7	9	○ FU0260S0		
22	30	5	22	30	29	5.7	7.7	○ FU0267S0		
22.4	30	5	22.4	30	29			○ FU2468S0		
23.5	31.5	5	23.5	31.5	30.5			○ FU0276S0		
24	32	5	24	32	31			○ FU0279S0		
25	33	5	25	33	32			7	9	○ FU2469S0
	35	6	25	35	34			○ FU2470S0		
26	34	5	26	34	33			5.7	8.7	○ FU0320S0
27	35	5	27	35	34					○ FU0321S0
28	35.5	5	28	35.5	34.5	○ FU0355S0				
	36	5	28	36	35	○ FU0357S0				
30	38	5	30	38	37	7	10			○ FU0382S0
	40	6	30	40	39					○ FU2055S0
31.5	41.5	6	31.5	41.5	40.5					○ FU2471S0
32	42	6	32	42	41					○ FU2263S0
33	43	6	33	43	42			○ FU0424S0		
34	44	6	34	44	43			○ FU0451S0		
35	45	6	35	45	44			○ FU0452S0		
35.5	45	6	35.5	45	44			○ FU2472S0		
	45.5	6	35.5	45.5	44.5	○ FU2240S0				
36	46	6	36	46	45	8	11	○ FU0497S0		
38	48	6	38	48	47			○ FU0567S0		
40	50	6	40	50	49			○ FU0572S0		
45	55	6	45	55	54			7	10	○ FU2662S0
	56	7	45	56	55					○ FU0619S0
46	56	6	46	56	55					○ FU0679S0
50	60	6	50	60	59					○ FU0694S0
53	63	6	53	63	62					○ FU0722S0
55	65	6	55	65	64	○ FU2473S0				
56	66	6	56	66	65	○ FU0746S0				
58	68	6	58	68	67	○ FU0750S0				
60	70	6	60	70	69	8	11	○ FU2474S0		
	71	7	60	71	70			○ FU0750S0		
61	71	6	61	71	70	7	10	○ FU2474S0		

Remark) When using packings with mark ● as rod packing, provide separate grooves.
When using packings with marks ●○ as piston packing, provide separate grooves.

HOW TO DETERMINE B DIMENSION

■ When using backup ring

Please determine B dimension according to the table below. If you require smaller B dimension (in case of piston seals) or larger B dimension (in case of rod seals) because of the cylinder configuration, please consult NOK.

Maximum Service Pressure		14MPa	21MPa
Material of Backup ring		19YF	
B Dimension	For rod	$B \leq \phi d + 1.0$	$B \leq \phi d + 0.5$
	For piston	$B \geq \phi D - 1.0$	$B \geq \phi D - 0.5$

■ When not using backup ring

To determine ϕB dimension, please refer to the graph in the right for the maximum extrusion gap (also refer page 26) considering the eccentricity of operating condition.

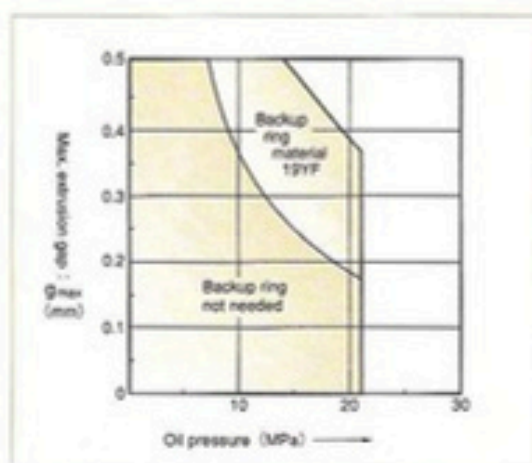

Nominal Size of Packing			Housing dimensions						NOK Part Number	
d	D	h	ϕd	ϕD	ϕD_1	H_A	H_B	C		
63	73	6	63	73	72	7	10	2.5	FU0786S0	
65	75	6	65	75	74				FU0809S0	
67	77	6	67	77	76				FU0828S0	
70	80	6	70	80	79				FU0849S0	
71	80	6	71	80	79				FU0879S0	
75	85	6	75	85	84				FU0901S0	
80	90	6	80	90	89				FU0939S0	
	95	9	80	95	94	10	13	FU0942S0		
85	95	6	85	95	94	7	10	FU2475S0		
	100	9	85	100	99	10	13	FU0984S0		
86	100	8.5	86	100	99	9.5	12.5	FU2476S0		
89	104	9	89	104	103	10	13	FU2372S0		
90	100	6	90	100	99	7	10	FU1021S0		
	105	9	90	105	104	10	13	FU1024S0		
95	110	9	95	110	109			FU1051S0		
96	111	9	96	111	110	10	13	FU2477S0		
98	112	8.5	98	112	111			9.5	12.5	FU1067S0
100	115	9	100	115	113			10	13	FU1082S0
105	120	9	105	120	118			9.5	12.5	FU1125S0
106	120	8.5	106	120	118			9.5	12.5	FU1135S0
110	125	9	110	125	123			10	13	FU1157S0
112	125	9	112	125	123					FU1179S0
115	130	9	115	130	128	9.5	12.5	FU1195S0		
118	132	8.5	118	132	130			FU1204S0		
125	140	9	125	140	138			10	13	FU1252S0
132	145	8.5	132	145	143	9.5	12.5	FU1291S0		
136	150	8.5	136	150	148			FU1306S0		
145	160	9	145	160	158			10	13	FU1343S0

F

UPH_{TYPE}

PACKINGS FOR BOTH PISTON AND ROD SEALS
NITRILE RUBBER (NBR)
FLUORORUBBER (FKM)



- Please designate NOK Part number and type & size on your order.

(Example) • Type Dimensions UPH 6.3 16.3 7.5

Type Sign

Nominal Size of Packing
described in order of inner diameter(d), outer diameter(D), and height(h)

• Part Number CU3308D0

- Please check the application range on pages D-2 and 3 before selecting the type.

Material	Standard : NOK A505 Heat resistant type : NOK F357
-----------------	---

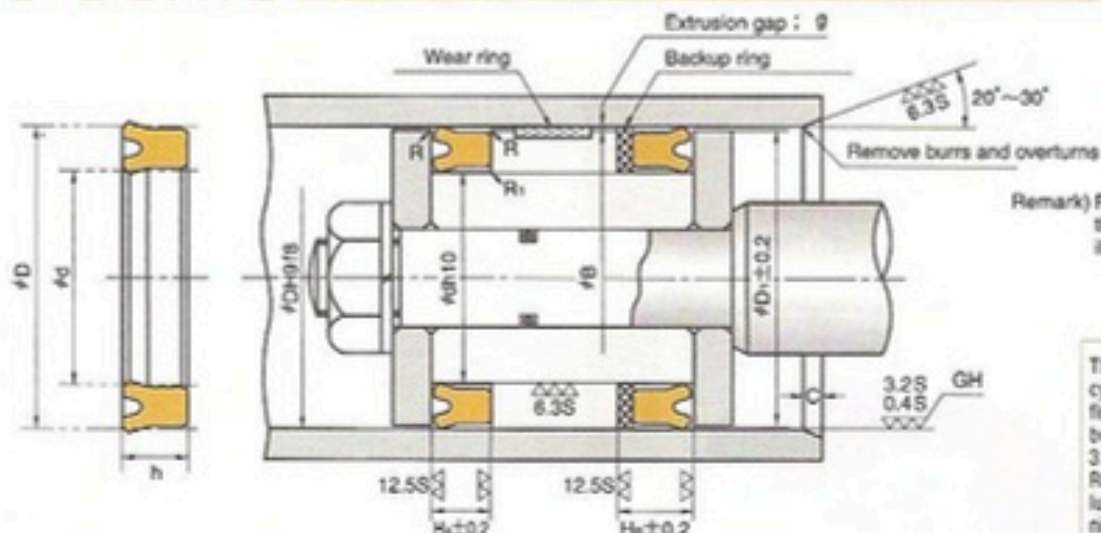

Remark) For the fitting drawing of the rod seals, refer to the illustration on page F-60.

R = 0.3 or below
R₁ = 0.5 or below

The inner surface of the cylinder tube should be finished by honing (GH) or burnishing (RLB) to 0.4 to 3.2 μm Rmax (0.1 to 0.8 μm Ra). Specially under severe lubricating condition, burnishing is required.

Nominal Size of Packing			Housing dimensions					C	Standard (A505)		Heat resistant (F357)	
d	D	h	φd	φD	φD ₁	H ₁	H ₂		NOK Part Number	Nominal number	NOK Part Number	Nominal number
6.3	16.3	7.5	6.3	16.3	15.3	8.5	10.5	2.5	CU3308D0	UPH-6.3		
	16.3	8	6.3	16.3	15.3	9	11		CU0024D0	UPH-6.3A		
7.1	17.1	7.5	7.1	17.1	16.1	8.5	10.5		CU3309D0	UPH-7.1		
	17.1	8	7.1	17.1	16.1	9	11		CU0030D0	UPH-7.1A		
8	18	7.5	8	18	17	8.5	10.5		CU0042D0	UPH-8		
	18	8	8	18	17	9	11		CU0043D1	UPH-8A	CU0043D2	UPH-8AF
9	19	7.5	9	19	18	8.5	10.5		CU3310D0	UPH-9		
	19	8	9	19	18	9	11		CU0054D0	UPH-9A		
10	20	7.5	10	20	19	8.5	10.5		CU0068D0	UPH-10		
	20	8	10	20	19	9	11		CU0069D1	UPH-10A		
11.2	21.2	7.5	11.2	21.2	20.2	8.5	10.5		CU3311D0	UPH-11.2		
	21.2	8	11.2	21.2	20.2	9	11		CU0081D0	UPH-11.2A		
12	25	8	12	25	24	9	11		CU0093D0	UPH-12	CU0093D3	UPH-12F
12.5	22.5	7.5	12.5	22.5	21.5	8.5	10.5		CU3312D0	UPH-12.5		
	22.5	8	12.5	22.5	21.5	9	11		CU0102D0	UPH-12.5A		
14	24	7.5	14	24	23	8.5	10.5		CU0121D0	UPH-14		
	24	8	14	24	23	9	11		CU0122D0	UPH-14A	CU0122D3	UPH-14AF
15	25	8	15	25	24	9	11		CU0135D0	UPH-15A		
	28	10	15	28	27	11	13		CU0137D0	UPH-15		
16	26	7.5	16	26	25	8.5	10.5		CU0156D0	UPH-16	CU0156D2	UPH-16F
	26	8	16	26	25	9	11		CU0157D1	UPH-16A		
	32	10	16	32	31	11	13		CU0161D0	UPH-16B		
18	28	8	18	28	27	9	11		CU0182D0	UPH-18A	CU0182D4	UPH-18AF
	31	10	18	31	30	11	13		CU0186D0	UPH-18		
	33	10	18	33	32	11	13	CU2196D0	UPH-18B			
18.5	31.5	10	18.5	31.5	30.5	11	13	CU3313D0	UPH-18.5			
20	30	8	20	30	29	9	11	CU0215D1	UPH-20A	CU0215D2	UPH-20AF	
	33	10	20	33	32	11	13	CU0221D0	UPH-20			
	35	10	20	35	34	11	13	CU0224D0	UPH-20B			
21.5	31.5	8	21.5	31.5	30.5	9	11	CU0239D0	UPH-21.5			
22	35	10	22	35	34	11	13	CU0249D0	UPH-22			
22.4	32.4	8	22.4	32.4	31.4	9	11	CU0263D0	UPH-22.4A	CU0263D3	UPH-22.4AF	
	35.4	10	22.4	35.4	34.4	11	13	CU0265D1	UPH-22.4			
25	35	8	25	35	34	9	11	CU0282D2	UPH-25A	CU0282D3	UPH-25AF	
	38	10	25	38	37	11	13	CU0288D0	UPH-25			
	40	10	25	40	39	11	13	CU0292D0	UPH-25B	CU0292D4	UPH-25BF	
	45	12	25	45	44	13	15	CU0301D0	UPH-25C			
25.5	35.5	8	25.5	35.5	34.5	9	12	CU0309D0	UPH-25.5			
27	40	10	27	40	39	11	14	CU2347D0	UPH-27			
28	40	10	28	40	39	11	14	CU0330D2	UPH-28A	CU0330D6	UPH-28AF	
	41	10	28	41	40	11	14	CU0335D0	UPH-28			
	43	10	28	43	42	11	14	CU0340D0	UPH-28B			

Remark) The Part number and the one stamped on the product might be different in case of heat resistant type.

HOW TO DETERMINE B DIMENSION

■ When using backup ring

Please determine B dimension according to the table below. If you require smaller B dimension (in case of piston seals) or larger B dimension (in case of rod seals) because of the cylinder configuration, please consult NOK.

Maximum Service Pressure	15MPa	32MPa
Material of Backup ring	19YF	
For rod	$B \leq \phi d + 1.0$	$B \leq \phi d + 0.5$
For piston	$B \geq \phi D - 1.0$	$B \geq \phi D - 0.5$

■ When not using backup ring

To determine ϕB dimension, please refer to the graph in the right for the maximum extrusion gap (also refer page 26) considering the eccentricity of operating condition.

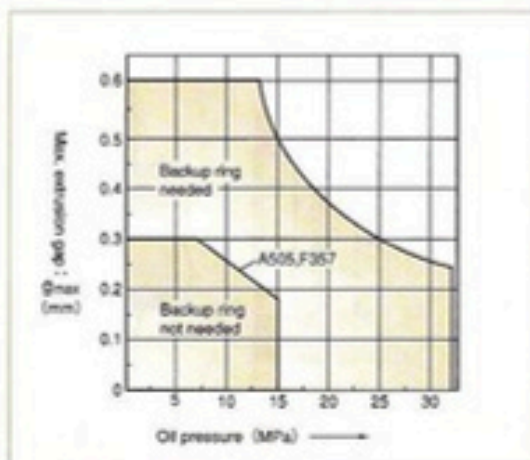

Nominal Size of Packing			Housing dimensions					Standard (A505)		Heat resistant (F357)		
d	D	h	ϕd	ϕD	ϕD_1	H_A	H_B	C	NOK Part Number	Nominal number	NOK Part Number	Nominal number
30	43	10	30	43	42	11	14	3.5	CU0364D0	UPH-30	CU0364D2	UPH-30F
	45	10	30	45	44	11	14		CU0368D2	UPH-30A	CU0368D8	UPH-30AF
31.5	44.5	10	31.5	44.5	43.5	11	14		CU0385D0	UPH-31.5		
	46.5	10	31.5	46.5	45.5	11	14		CU0387D1	UPH-31.5A		
32	45	10	32	45	44	11	14		CU2451D0	UPH-32		
	46	10	32	46	45	11	14		CU0403D0	UPH-32A		
	48	10	32	48	47	11	14		CU0404D0	UPH-32B		
34	50	12	34	50	49	13	16		CU0408D0	UPH-34		
	35	50	10	35	50	49	11		14	CU0437D4	UPH-35B	CU0437D5
50		12	35	50	49	13	16		CU0438D0	UPH-35		
51		12	35	51	50	13	16		CU0441D0	UPH-35A		
35.5	50.5	10	35.5	50.5	49.5	11	14		CU0456D2	UPH-35.5A	CU0456D6	UPH-35.5AF
	51.5	12	35.5	51.5	50.5	13	16	CU0458D0	UPH-35.5	CU0458D2	UPH-35.5F	
38	52	10	38	52	51	11	14	CU0470D1	UPH-38			
40	55	10	40	55	54	11	14	CU0505D3	UPH-40A	CU0505D2	UPH-40AF	
	56	10	40	56	55	11	14	CU0508D0	UPH-40B			
	56	12	40	56	55	13	16	CU0509D0	UPH-40			
	60	12	40	60	59	13	16	CU0514D0	UPH-40C			
41	56	10	41	56	55	11	14	CU0523D0	UPH-41			
45	60	10	45	60	59	11	14	CU0577D5	UPH-45A	CU0577D9	UPH-45AF	
	60	12	45	60	59	13	16	CU0578D0	UPH-45B			
	61	12	45	61	60	13	16	CU0580D0	UPH-45	CU0580D3	UPH-45F	
47	63	12	47	63	62	13	16	CU0591D0	UPH-47			
48	63	10	48	63	62	11	14	CU0601D1	UPH-48	CU0601D4	UPH-48F	
	65	10	50	65	64	11	14	CU0631D2	UPH-50A	CU0631D7	UPH-50AF	
	66	12	50	66	65	13	16	CU0635D0	UPH-50	CU0635D3	UPH-50F	
	70	12	50	70	69	13	16	CU0639D3	UPH-50B	CU0639D4	UPH-50BF	
51	71	12	51	71	70	13	16	CU0669D0	UPH-51			
	53	69	12	53	69	68	13	16	CU3317D0	UPH-53		
73		12	53	73	72	13	16	CU0683D0	UPH-53A			
55		71	12	55	71	70	13	16	CU0704D1	UPH-55		
	75	12	55	75	74	13	16	CU0708D2	UPH-55A	CU0708D6	UPH-55AF	
	80	15	55	80	79	16	19	CU0712D0	UPH-55B			
56	72	12	56	72	71	13	16	CU0727D0	UPH-56	CU0727D2	UPH-56F	
	76	12	56	76	75	13	16	CU0728D1	UPH-56A	CU0728D4	UPH-56AF	
60	76	12	60	76	75	13	16	CU0757D1	UPH-60			
	80	12	60	80	79	13	16	CU0761D1	UPH-60A	CU0761D6	UPH-60AF	
63	79	12	63	79	78	13	16	CU0791D0	UPH-63			
	83	12	63	83	82	13	16	CU0793D1	UPH-63A	CU0793D3	UPH-63AF	
64	80	12	64	80	79	13	16	CU2123D1	UPH-64	CU2123D2	UPH-64F	
65	81	12	65	81	80	13	16	CU3318D0	UPH-65			
	85	12	65	85	84	13	16	CU0819D1	UPH-65A	CU0819D2	UPH-65AF	

Remark) The Part number and the one stamped on the product might be different in case of heat resistant type.

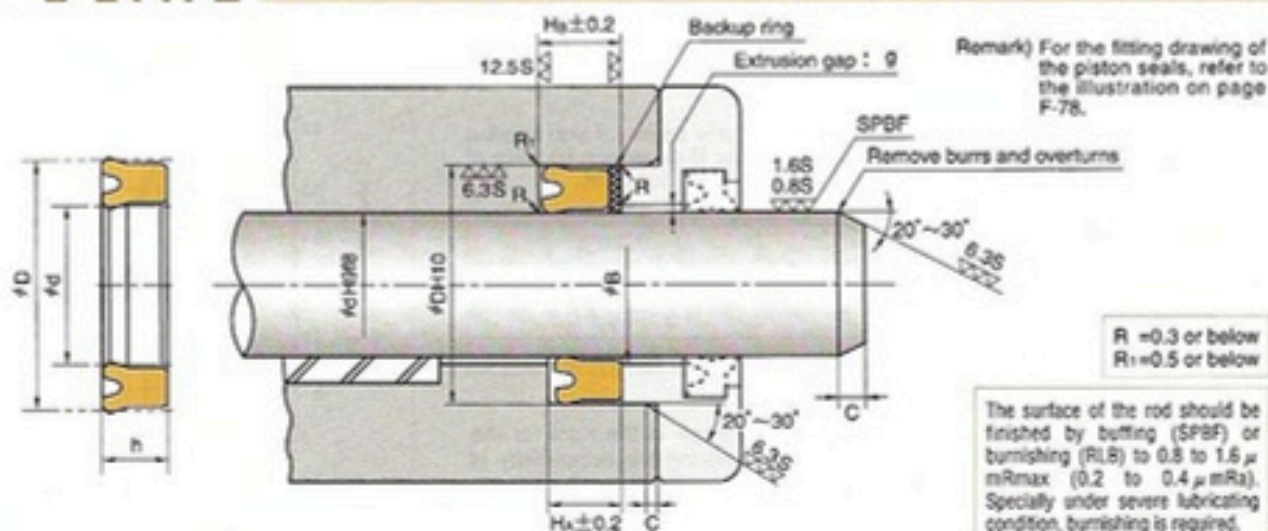

Nominal Size of Packing			Housing dimensions					Standard (A505)		Heat resistant (F357)		
d	D	h	φd	φD	φD ₁	H _k	H _b	C	NOK Part Number	Nominal number	NOK Part Number	Nominal number
67	87	12	67	87	86	13	16	5	CU0831D0	UPH-67A	CU0831D3	UPH-67AF
	87	15	67	87	86	16	19		CU3319D0	UPH-67		
70	90	12	70	90	89	13	16		CU0862D1	UPH-70A	CU0862D4	UPH-70AF
	90	15	70	90	89	16	19		CU0864D0	UPH-70	CU0864D2	UPH-70F
71	91	12	71	91	90	13	16		CU0884D1	UPH-71A	CU0884D3	UPH-71AF
	91	15	71	91	90	16	19		CU0885D0	UPH-71		
75	95	12	75	95	94	13	16		CU0910D1	UPH-75A		
	95	15	75	95	94	16	19		CU0911D1	UPH-75	CU0911D2	UPH-75F
80	100	12	80	100	99	13	16		CU0948D1	UPH-80A	CU0948D9	UPH-80AF
	100	15	80	100	99	16	19		CU0949D2	UPH-80	CU0949D3	UPH-80F
85	105	12	85	105	104	13	16		CU0989D1	UPH-85A	CU0989D3	UPH-85AF
	105	15	85	105	104	16	19		CU0990D0	UPH-85		
90	110	12	90	110	109	13	16		CU1030D3	UPH-90A	CU1030D7	UPH-90AF
	110	15	90	110	109	16	19		CU1031D0	UPH-90	CU1031D3	UPH-90F
92	112	12	92	112	111	13	16		CU1042D1	UPH-92A		
	112	15	92	112	111	16	19		CU2132D1	UPH-92	CU2132D2	UPH-92F
95	115	12	95	115	114	13	16		CU1056D0	UPH-95A	CU1056D4	UPH-95AF
	115	15	95	115	114	16	19		CU1057D1	UPH-95	CU1057D3	UPH-95F
100	120	15	95	120	118	16	19		CU1061D0	UPH-95B		
	120	12	100	120	118	13	16		CU1089D3	UPH-100A	CU1089D7	UPH-100AF
	120	15	100	120	118	16	19	CU1091D0	UPH-100	CU1091D3	UPH-100F	
105	125	15	105	125	123	16	19	CU1096D0	UPH-100B	CU1096D3	UPH-100BF	
	125	15	105	125	123	16	19	CU1129D2	UPH-105	CU1129D4	UPH-105F	
106	126	15	106	126	124	16	19	CU1138D0	UPH-106			
110	130	15	110	130	128	16	19	CU1165D1	UPH-110	CU1165D4	UPH-110F	
112	132	15	112	132	130	16	19	CU1182D0	UPH-112	CU1182D3	UPH-112F	
115	135	15	115	135	133	16	19	CU1198D0	UPH-115			
118	138	15	118	138	136	16	19	CU1207D0	UPH-118	CU1207D2	UPH-118F	
120	140	15	120	140	138	16	19	CU1224D2	UPH-120	CU1224D1	UPH-120F	
125	145	15	125	145	143	16	19	CU1257D0	UPH-125A			
	150	19	125	150	148	20	23	CU1933D0	UPH-125	CU1933D2	UPH-125F	
130	150	15	130	150	148	16	19	CU1284D2	UPH-130A	CU1284D4	UPH-130F	
	155	19	130	155	153	20	23	CU3320D0	UPH-130			
132	152	15	132	152	150	16	19	CU1292D0	UPH-132A			
	157	19	132	157	155	20	23	CU2703D1	UPH-132	CU2703D2	UPH-132F	
135	155	15	135	155	153	16	19	CU1305D0	UPH-135B			
	160	15.7	135	160	158	17	20	CU3322D0	UPH-135A			
140	160	19	135	160	158	20	23	CU1960D0	UPH-135			
	160	15	140	160	158	16	19	CU1327D1	UPH-140A	CU1327D4	UPH-140F	
145	165	19	140	165	163	20	23	CU1332D2	UPH-140			
	165	15	145	165	163	16	19	CU1344D0	UPH-145A			
	170	19	145	170	168	20	23	CU2348D0	UPH-145	CU2348D1	UPH-145F	

Remark) The Part number and the one stamped on the product might be different in case of heat resistant type.

HOW TO DETERMINE B DIMENSION

■ When using backup ring

Please determine B dimension according to the table below. If you require smaller B dimension (in case of piston seals) or larger B dimension (in case of rod seals) because of the cylinder configuration, please consult NOK.

Maximum Service Pressure	15MPa	32MPa
Material of Backup ring	19YF	
For rod	$B \leq \phi d + 1.0$	$B \leq \phi d + 0.5$
For piston	$B \geq \phi D - 1.0$	$B \geq \phi D - 0.5$

■ When not using backup ring

To determine ϕB dimension, please refer to the graph in the right for the maximum extrusion gap (also refer page 26) considering the eccentricity of operating condition.

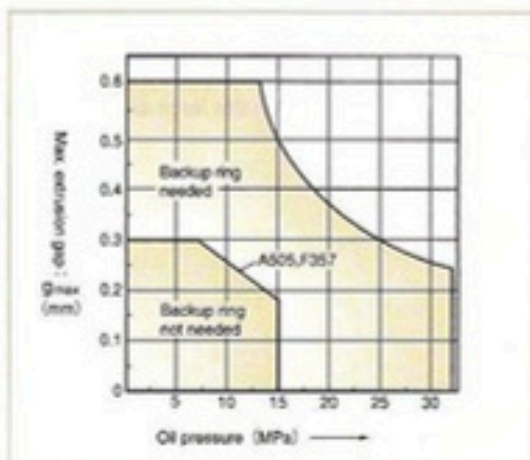

Nominal Size of Packing			Housing dimensions					Standard (A505)		Heat resistant (F357)		
d	D	h	ϕd	ϕD	ϕD_1	H _A	H _B	C	NOK Part Number	Nominal number	NOK Part Number	Nominal number
150	170	15	150	170	168	16	19	6.5	CU1363D2	UPH-150A	CU1363D3	UPH-150AF
	175	19	150	175	173	20	23		CU1367D0	UPH-150		
155	180	15	155	180	178	16	20		CU1391D2	UPH-155B	CU1391D4	UPH-155BF
	180	15.7	155	180	178	17	21		CU3323D0	UPH-155A		
160	180	19	155	180	178	20	24		CU1393D0	UPH-155		
	185	15	160	185	183	16	20		CU1413D0	UPH-160A		
165	185	19	160	185	183	20	24		CU2349D0	UPH-160		
	190	15	165	190	188	16	20		CU1431D0	UPH-165A		
170	190	19	165	190	188	20	24		CU3324D0	UPH-165		
	195	15	170	195	193	16	20		CU1448D1	UPH-170A		
175	195	19	170	195	193	20	24		CU3325D0	UPH-170		
	200	15	175	200	198	16	20		CU1461D2	UPH-175B	CU1461D3	UPH-175ABF
	200	15.7	175	200	198	17	21		CU3326D0	UPH-175A		
180	200	19	175	200	198	20	24		CU1463D1	UPH-175		
	205	15	180	205	203	16	20		CU1490D0	UPH-180A		
	205	19	180	205	203	20	24		CU1492D0	UPH-180		
185	210	15	185	210	208	16	20		CU1504D0	UPH-185		
190	215	15	190	215	213	16	20		CU1519D0	UPH-190A	CU1519D2	UPH-190AF
	215	19	190	215	213	20	24		CU3327D0	UPH-190		
199	224	15	199	224	222	16	20		CU1532D0	UPH-199B		
	224	15.7	199	224	222	17	21	CU3329D0	UPH-199A			
	224	19	199	224	222	20	24	CU1535D0	UPH-199			
200	225	15	200	225	223	16	20	CU1547D0	UPH-200A	CU1547D4	UPH-200AF	
	225	19	200	225	223	20	24	CU2350D0	UPH-200			
210	235	18	210	235	233	19	23	CU1579D0	UPH-210			
212	237	19	212	237	235	20	24	CU1585D0	UPH-212			
224	249	19	224	249	247	20	24	CU2926D0	UPH-224			
225	250	18	225	250	248	19	23	CU1625D0	UPH-225A			
	250	19	225	250	248	20	24	CU1626D0	UPH-225			
236	261	19	236	261	259	20	24	CU1649D1	UPH-236			
250	275	19	250	275	273	20	24	CU1683D1	UPH-250	CU1694D3	UPH-255F	
255	280	19	255	280	278	20	24	CU1694D0	UPH-255			
265	297	24	265	297	295	26	30	CU1714D0	UPH-265			
	300	18	270	300	298	19	23	CU1722D0	UPH-270A			
270	300	24	270	300	298	26	30	CU1725D0	UPH-270			
	310	22	280	310	308	24	28	CU2774D0	UPH-280A			
280	312	24	280	312	310	26	30	CU2166D0	UPH-280			
	315	24	283	315	313	26	30	CU1918D0	UPH-283			
290	320	18	290	320	318	19	23	CU1750D0	UPH-290A			
	320	22	290	320	318	24	28	CU1752D0	UPH-290			
300	332	24	300	332	330	26	30	CU2351D0	UPH-300			

Remark) The Part number and the one stamped on the product might be different in case of heat resistant type.

TYPE PACKINGS FOR BOTH PISTON AND ROD SEALS

Large size dimension table

■ When using packings on this large size dimension table, please consult NOK.

Nominal Size of Packing			Housing dimensions					Standard (A505)		Heat resistant (F357)		
d	D	h	φd	φD	φD ₁	H ₁	H ₂	C	NOK Part Number	Nominal number	NOK Part Number	Nominal number
310	340	18	310	340	338	19	23	10	CU1772D0	UPH-310A		
	340	22	310	340	338	24	28		CU1773D0	UPH-310		
315	347	24	315	347	345	26	30		CU3064D0	UPH-315		
320	340	12	320	340	338	13	17		CU2101D0	UPH-320A		
	350	22	320	350	348	24	28		CU1780D0	UPH-320		
323	355	24	323	355	353	26	30		CU1784D0	UPH-323		
330	355	16	330	355	353	17	21		CU1786D0	UPH-330A		
	356	20	330	356	354	22	26		CU1787D0	UPH-330B		
	360	22	330	360	358	24	28		CU1789D0	UPH-330		
335	355	14	335	355	353	15	19		CU1793D1	UPH-335A		
	367	24	335	367	365	26	30		CU2197D0	UPH-335		
340	370	22	340	370	368	24	28		CU1795D0	UPH-340		
345	365	14	345	365	363	15	19		CU2243D0	UPH-345		
350	370	14	350	370	368	15	19		CU2302D0	UPH-350A		
	380	22	350	380	378	24	28		CU1799D2	UPH-350		
355	385	22	355	385	383	24	28		CU1801D0	UPH-355A		
	387	24	355	387	385	26	30		CU1916D0	UPH-355		
360	390	22	360	390	388	24	28		CU1803D0	UPH-360		
365	395	22	365	395	393	24	28		CU1805D0	UPH-365		
368	400	24	368	400	398	26	30		CU1807D0	UPH-368		
370	400	23	370	400	398	25	29		CU1810D0	UPH-370A		
	400	25	370	400	398	27	31		CU1811D0	UPH-370		
371	396	16	371	396	394	17	21		CU2303D0	UPH-371		
375	407	24	375	407	405	26	30		CU3357D0	UPH-375		
380	400	15	380	400	398	16	20		CU1813D0	UPH-380A		
	410	15	380	410	408	16	20		CU1815D0	UPH-380B		
	420	30	380	420	418	32	36		CU2162D0	UPH-380		
390	420	22	390	420	418	24	28		CU1818D0	UPH-390		
395	425	22	395	425	423	24	28		CU1819D0	UPH-395		
400	430	22	400	430	428	24	28		CU1823D0	UPH-400A		
	430	25	400	430	428	27	31		CU2007D0	UPH-400B		
	432	24	400	432	430	26	30		CU3358D0	UPH-400		

Nominal Size of Packing			Housing dimensions					Standard (A505)		Heat resistant (F357)		
d	D	h	φd	φD	φD ₁	H _a	H _b	C	NOK Part Number	Nominal number	NOK Part Number	Nominal number
420	455	25	420	455	453	27	32	10	CU1833D0	UPH-420		
425	457	24	425	457	455	26	31		CU1917D0	UPH-425		
430	470	20	430	470	468	22	27		CU1837D0	UPH-430		
435	470	25	435	470	468	27	32		CU1841D0	UPH-435		
440	480	35	440	480	478	37	42		CU1843D0	UPH-440		
445	470	18	445	470	468	19	24		CU2244D0	UPH-445		
450	480	22	450	480	478	24	29		CU1844D0	UPH-450A		
	482	24	450	482	480	26	31		CU3359D0	UPH-450		
460	500	20	460	500	498	22	27		CU1850D0	UPH-460		
475	507	24	475	507	505	26	31		CU1853D0	UPH-475		
480	505	18	480	505	503	19	24		CU2245D0	UPH-480A		
490	530	25	490	530	528	27	32		CU1855D0	UPH-490		
520	550	17	520	550	548	18	23		CU2189D0	UPH-520A		
525	555	15	525	555	553	16	21		CU1860D0	UPH-525		
530	570	20	530	570	568	22	27		CU2084D0	UPH-530A		
540	560	14	540	560	558	15	20		CU2037D0	UPH-540		
570	600	17	570	600	598	18	23		CU2190D0	UPH-570A		
600	630	20	600	630	628	22	27		CU2160D0	UPH-600A		
	630	28	600	630	628	30	35		CU2036D0	UPH-600B		
	640	30	600	640	638	32	37		CU1868D0	UPH-600		
640	685	25	640	685	683	27	32	CU2284D0	UPH-640			
700	730	15	700	730	728	16	21	CU1873D0	UPH-700A			
760	800	34	760	800	798	36	41	CU1877D0	UPH-760			
768	800	30	768	800	798	32	37	CU1878D0	UPH-768			
818	850	24	818	850	848	26	31	CU1882D1	UPH-818			
825	850	15.5	825	850	848	16.5	21.5	CU1883D0	UPH-825A			
	860	27	825	860	858	29	34	CU2124D0	UPH-825			
925	950	14	925	950	948	15	20	CU2325D0	UPH-925			
950	980	20	950	980	978	22	27	CU1892D0	UPH-950			
1020	1050	18	1020	1050	1048	19	24	CU1894D0	UPH-1020A			
1025	1055	15	1025	1055	1053	16	21	CU1895D0	UPH-1025			
1100	1140	20	1100	1140	1138	22	27	CU2192D0	UPH-1100			
1220	1280	30	1220	1280	1278	32	37	CU1899D0	UPH-1220			
1560	1600	20	1560	1600	1598	22	27	CU2191D0	UPH-1560			
1620	1680	30	1620	1680	1678	32	37	CU1904D0	UPH-1620			

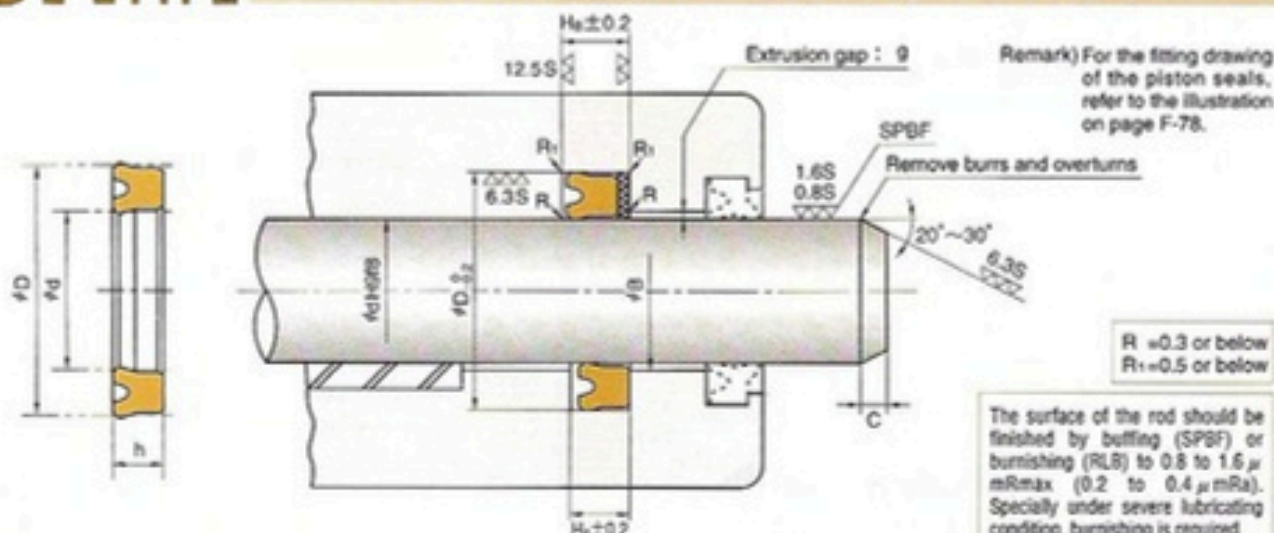

Nominal Size of Packing			Housing dimensions					Standard (A505)		Heat resistant (F357)		
d	D	h	#d	#D	#D ₁	H _h	H _g	C	NOK Part Number	Nominal number	NOK Part Number	Nominal number
14	22	5	14	22	21	5.7	7.7	2	● CU2692K0	USH-14		
16	24	5	16	24	23	5.7	7.7		● CU2548K0	USH-16	● CU2548K2	USH-16F
18	26	5	18	26	25	5.7	7.7		CU0180K0	USH-18	CU0180K6	USH-18F
20	28	5	20	28	27	5.7	7.7		CU0212K0	USH-20	CU0212K4	USH-20F
22	30	5	22	30	29	5.7	7.7		CU3017K0	USH-22		
22.4	30	5	22.4	30	29	5.7	7.7		CU0260K0	USH-22.4	CU0260K3	USH-22.4F
23.5	31.5	5	23.5	31.5	30.5	5.7	7.7		CU0267K0	USH-23.5		
24	32	5	24	32	31	5.7	7.7		CU2971K0	USH-24		
25	33	5	25	33	32	5.7	7.7		CU0276K0	USH-25	CU0276K3	USH-25F
27	35	5	27	35	34	5.7	8.7		CU3187K0	USH-27		
28	35.5	5	28	35.5	34.5	5.7	8.7		CU0320K0	USH-28	CU0320K2	USH-28F
	36	5	28	36	35	5.7	8.7		CU2536K0	USH-28A		
30	40	6	30	40	39	7	10		CU0357K0	USH-30	CU0357K6	USH-30F
31.5	41.5	6	31.5	41.5	40.5	7	10		CU0382K0	USH-31.5	CU0382K1	USH-31.5F
32	42	6	32	42	41	7	10		CU2819K0	USH-32		
35	45	6	35	45	44	7	10		CU0424K0	USH-35	CU0424K3	USH-35F
35.5	45	6	35.5	45	44	7	10		CU0451K0	USH-35.5	CU0451K1	USH-35.5F
	45.5	6	35.5	45.5	44.5	7	10		CU3253K0	USH-35.5A		
36	46	6	36	46	45	7	10	CU3040K1	USH-36			
40	50	6	40	50	49	7	10	CU0497K0	USH-40	CU0497K3	USH-40F	
45	55	6	45	55	54	7	10	CU0567K0	USH-45	CU0567K4	USH-45F	
	56	7	45	56	55	8	11	CU0572K0	USH-45A	CU0572K1	USH-45AF	
50	60	6	50	60	59	7	10	CU0619K0	USH-50	CU0619K4	USH-50F	
53	63	6	53	63	62	7	10	CU0679K0	USH-53	CU0679K4	USH-53F	
55	65	6	55	65	64	7	10	CU0694K0	USH-55			
56	66	6	56	66	65	7	10	CU0722K0	USH-56	CU0722K2	USH-56F	
58	68	6	58	68	67	7	10	CU3255K0	USH-58			
60	70	6	60	70	69	7	10	CU0746K0	USH-60	CU0746K3	USH-60F	
	71	7	60	71	70	8	11	CU0750K0	USH-60A			
63	73	6	63	73	72	7	10	CU0786K0	USH-63	CU0786K2	USH-63F	
65	75	6	65	75	74	7	10	CU0809K0	USH-65	CU0809K2	UPH-65F	
67	77	6	67	77	76	7	10	CU0828K0	USH-67			
70	80	6	70	80	79	7	10	CU0849K0	USH-70	CU0849K4	USH-70F	
71	80	6	71	80	79	7	10	CU0879K0	USH-71	CU0879K1	USH-71F	
75	85	6	75	85	84	7	10	CU0901K0	USH-75			

Remark) When using packings with mark ● as rod packing, provide separate grooves.

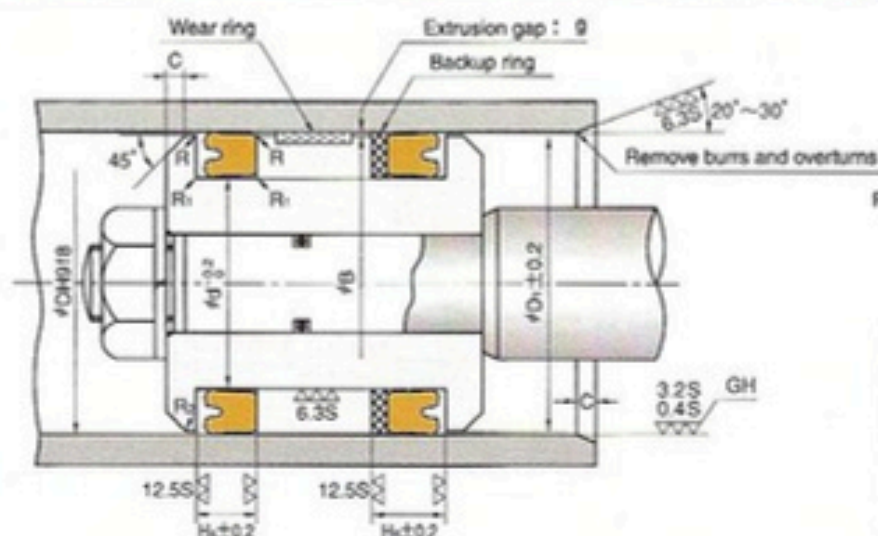

Remark) For B dimension, refer to page F-17.

$R = 0.3$ or below
 $R_1 = 0.5$ or below
 $R_2 = 1$

The inner surface of the cylinder tube should be finished by honing (GH) or burnishing (RLB) to 0.4 to 3.2 μm Rmax (0.1 to 0.8 μm Ra). Specially under severe lubricating condition, burnishing is required.

Nominal Size of Packing			Housing dimensions					Standard (A505)		Heat resistant (F357)			
d	D	h	ϕd	ϕD	ϕD_1	H_A	H_B	C	NOK Part Number	Nominal number	NOK Part Number	Nominal number	
80	90	6	80	90	89	7	10	2.5	CU0939K0	USH-80	CU0939K3	USH-80F	
85	95	6	85	95	94	7	10		CU1959K0	USH-85A			
	100	9	85	100	98	10	13		CU0984K0	USH-85	CU0984K4	USH-85F	
90	105	9	90	105	103	10	13		CU1024K0	USH-90	CU1024K4	USH-90F	
95	110	9	95	110	108	10	13		CU1051K0	USH-95	CU1051K3	USH-95F	
98	112	8.5	98	112	110	9.5	12.5		CU1067K0	USH-98	CU1067K2	USH-98F	
100	115	9	100	115	113	10	13		CU1082K0	USH-100	CU1082K3	USH-100F	
106	120	8.5	106	120	118	9.5	12.5		CU1135K0	USH-106			
	125	8.5	112	125	123	9.5	12.5		CU1178K0	USH-112	CU1178K1	USH-112F	
112	125	9	112	125	123	10	13		CU1179K0	USH-112A			
	132	8.5	118	132	130	9.5	12.5		CU1204K0	USH-118			
125	140	9	125	140	138	10	13		4	CU1252K0	USH-125	CU1252K2	USH-125F
130	145	9	130	145	143	10	13			CU1280K0	USH-130		
132	145	8.5	132	145	143	9.5	12.5			CU1291K0	USH-132		
136	150	8.5	136	150	148	9.5	12.5			CU1306K0	USH-136	CU1306K3	USH-136F
140	155	9	140	155	153	10	13			CU1323K0	USH-140	CU1323K1	USH-140F
145	160	9	145	160	158	10	13			CU1343K0	USH-145	CU1343K2	USH-145F
150	165	9	150	165	163	10	13			CU1359K0	USH-150	CU1359K1	UPH-150F
155	170	9	155	170	168	10	14	CU3261K0		USH-155			
160	175	9	160	175	173	10	14	CU1406K0		USH-160			
165	180	9	165	180	178	10	14	CU1429K0		USH-165	CU1429K2	USH-165F	
175	190	9	175	190	188	10	14	CU3038K0		USH-175			
180	200	12	180	200	198	13	17	CU1483K0		USH-180	CU1483K2	UPH-180F	
190	210	12	190	210	208	13	17	CU2516K0		USH-190			
200	220	12	200	220	218	13	17	CU1543K0		USH-200	CU1543K1	USH-200F	
204	224	12	204	224	222	13	17	CU1563K0		USH-204			
224	244	12	224	244	242	13	17	CU1609K0		USH-224			
230	250	12	230	250	248	13	17	5		CU1637K0	USH-230		
240	260	12	240	260	258	13	17			CU1657K0	USH-240		
250	270	12	250	270	268	13	17	CU1678K0	USH-250				
260	280	14	260	280	278	15	19	CU1702K0	USH-260	CU1702K1	UPH-260F		
280	300	14	280	300	298	15	19	CU1962K0	USH-280				
295	315	14	295	315	313	15	19	CU1756K0	USH-295				

V99F_{TYPE}

PACKINGS FOR BOTH PISTON AND ROD SEALS
FABRIC REINFORCED NITRILE RUBBER



● Please designate NOK Part number and type & size on your order.

(1) In case of V packing only

VP F 6.3 CV0002C0
 V packing Nominal number Part Number

(2) In case of adapter

VM1- 6.3 CP3673A0
 Nominal number Part Number

(3) In case of the combination of V packing and adapter
(In this case, the part number does not need to be designated.)

VPF 6.3 - 3 1 1
 V packing Nominal number Number of V packings in use Type of male adapter Type of female adapter
 1... fabric reinforced nitrile rubber 2... equivalent to BC3

● Please check the application range on pages D-2 and 3 before selecting the type.

Material	V packing only	NOK 21AG (fabric reinforced nitrile rubber)																			
	Adapter	Type 1 : NOK 21AG (fabric reinforced nitrile rubber) Type 2 : equivalent to BC3 (bronze)																			
Caution for application	<p>1. Initial tightening torque After fitting into the groove, adjust the tightening torque by using shims according to the below instruction. These figures do not mean the final tightening torque.</p> <p>Initial tightening torque (reference value) (mm)</p> <table border="1"> <thead> <tr> <th rowspan="2">Nominal number</th> <th colspan="3">Number of packings</th> </tr> <tr> <th>3</th> <th>4</th> <th>5</th> </tr> </thead> <tbody> <tr> <td>F6.3~250</td> <td>0.45</td> <td>0.60</td> <td>0.75</td> </tr> <tr> <td>F265~500</td> <td>0.75</td> <td>1.00</td> <td>1.25</td> </tr> <tr> <td>F530~650</td> <td>1.20</td> <td>1.60</td> <td>2.00</td> </tr> </tbody> </table>		Nominal number	Number of packings			3	4	5	F6.3~250	0.45	0.60	0.75	F265~500	0.75	1.00	1.25	F530~650	1.20	1.60	2.00
	Nominal number	Number of packings																			
3		4	5																		
F6.3~250	0.45	0.60	0.75																		
F265~500	0.75	1.00	1.25																		
F530~650	1.20	1.60	2.00																		
<p>2. About the material of adapter If the operation pressure exceeds 8MPa, use the material of BC equivalent.</p>																					

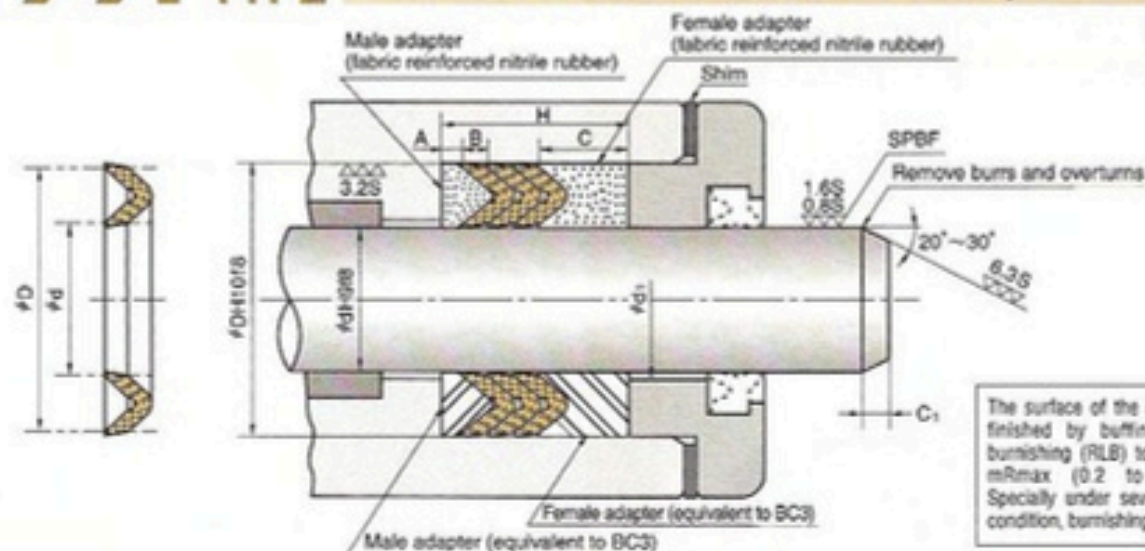

The surface of the rod should be finished by buffing (SPBF) or burnishing (RLB) to 0.5 to 1.6 μm Rmax (0.2 to 0.4 μm Ra). Specially under severe lubricating condition, burnishing is required.

Nominal Number	Nominal Size of Packing			NOK Part Number	Adapter size		Installation length H			C ₁	φd ₁	φD ₁	
	d	D	B		A	C	Number of packings						
F 6.3	6.3	16.3	3 ^{+0.02} _{-0.02}	CV0002C0						2	d+1	D-1	
F 7.1	7.1	17.1		CV0006C0									
F 8	8	18		CV0011C0									
F 9	9	19		CV0019C0	5	17	20	23	2.5				
F 10	10	20		CV0028C0									
F 11.2	11.2	21.2		CV0038C0									
F 12.5	12.5	22.5		CV0047C0									
F 14	14	24		CV0057C0									
F 16	16	26		CV0085C0									
F 15	15	28		CV0071C0	6.5	18.5	21.5	24.5	3.5				
F 18	18	31		CV0109C0									
F 18.5	18.5	31.5		CV0114C0									
F 20	20	33		CV0132C0									
F 22.4	22.4	35.4		CV0163C0									
F 25	25	38		CV0176C0									
F 27	27	40		CV0220C0									
F 28	28	41		CV0231C0									
F 31.5	31.5	44.5		CV0280C0									
F 32	32	45	CV0293C0										
F 34	34	50	CV0309C0	8						23	27	31	4
F 35.5	35.5	51.5	CV0339C0										
F 40	40	56	CV0370C0										
F 45	45	61	CV0418C0										
F 47	47	63	CV0441C0										
F 50	50	66	CV0457C0										
F 53	53	69	CV0503C0										
F 55	55	71	CV0518C0										
F 56	56	72	CV0539C0										
F 60	60	76	CV0562C0										
F 63	63	79	CV0599C0										
F 64	64	80	CV0620C0		10	28	33	38	5				
F 67	67	87	CV0651C0										
F 70	70	90	CV0674C0										
F 71	71	91	CV0701C0										
F 75	75	96	CV0711C0										
F 80	80	100	CV0755C0										
F 85	85	105	CV0793C0										
F 90	90	110	CV0827C0										
F 92	92	112	CV0850C0										
F 95	95	115	CV0855C0										
F 100	100	120	CV0873Y0										

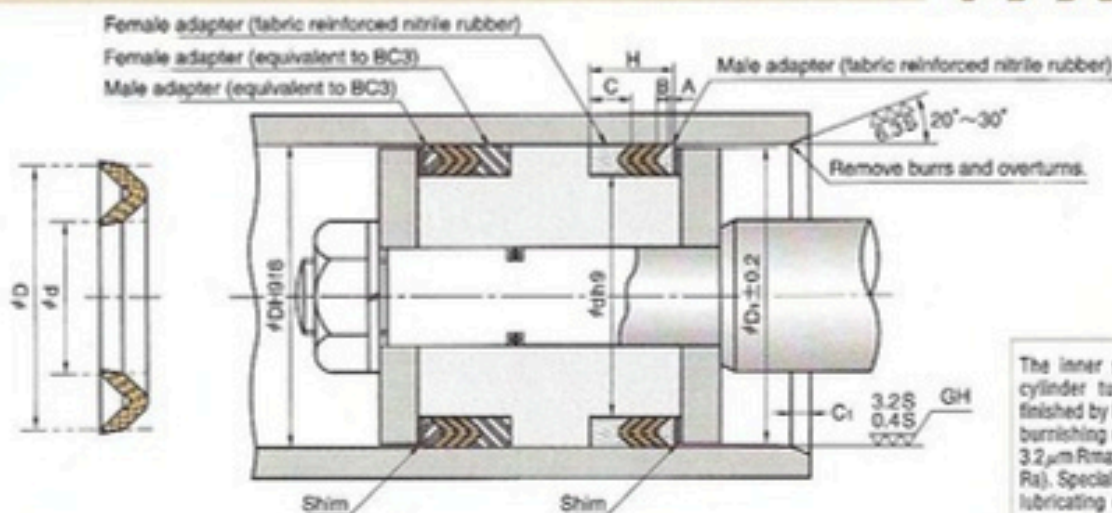

Fabric reinforced nitrile rubber adapter				Metal (equivalent to BC3) adapter			
Male		Female		Male		Female	
Nominal number	NOK Part Number	Nominal number	NOK Part Number	Nominal number	NOK Part Number	Nominal number	NOK Part Number
VM1- 6.3	CP3673A0	VF1- 6.3	CP0839A0	VM2- 6.3	CP3673B0	VF2- 6.3	CP0840B0
VM1- 7.1	CP3044A0	VF1- 7.1	CP0051A0	VM2- 7.1	CP3044B0	VF2- 7.1	CP0841B0
VM1- 8	CP3081A0	VF1- 8	CP0775A0	VM2- 8	CP3081B0	VF2- 8	CP0091B0
VM1- 9	CP3646A0	VF1- 9	CP0842A0	VM2- 9	CP3646B0	VF2- 9	CP0776B0
VM1- 10	CP3080A0	VF1- 10	CP0777A0	VM2- 10	CP3080B0	VF2- 10	CP0778B0
VM1- 11.2	CP3674A0	VF1- 11.2	CP0843A0	VM2- 11.2	CP3674B0	VF2- 11.2	CP0844B0
VM1- 12.5	CP3077A0	VF1- 12.5	CP0821A0	VM2- 12.5	CP3077B0	VF2- 12.5	CP0086B0
VM1- 14	CP3055A0	VF1- 14	CP0063A0	VM2- 14	CP3055B0	VF2- 14	CP0779B0
VM1- 16	CP3247A0	VF1- 16	CP0780A0	VM2- 16	CP3247B1	VF2- 16	CP0781B0
VM1- 15	CP3082A0	VF1- 15	CP0092A0	VM2- 15	CP3082B0	VF2- 15	CP0093B0
VM1- 18	CP3115A0	VF1- 18	CP0782A0	VM2- 18	CP3115B0	VF2- 18	CP0137B0
VM1- 18.5	CP3647A0	VF1- 18.5	CP0845A0	VM2- 18.5	CP3647B0	VF2- 18.5	CP0783B0
VM1- 20	CP3056A0	VF1- 20	CP0064A0	VM2- 20	CP3056B0	VF2- 20	CP0094B0
VM1- 22.4	CP3083A0	VF1- 22.4	CP0095A0	VM2- 22.4	CP3083B0	VF2- 22.4	CP0784B0
VM1- 25	CP3084A0	VF1- 25	CP0097A0	VM2- 25	CP3084B0	VF2- 25	CP0096B0
VM1- 27	CP3648A0	VF1- 27	CP0785A0	VM2- 27	CP3648B0	VF2- 27	CP0786B0
VM1- 28	CP3070A0	VF1- 28	CP0098A0	VM2- 28	CP3070B0	VF2- 28	CP0079B0
VM1- 31.5	CP3053A0	VF1- 31.5	CP0787A0	VM2- 31.5	CP3053B0	VF2- 31.5	CP0061B0
VM1- 32	CP3078A0	VF1- 32	CP0099A0	VM2- 32	CP3078B0	VF2- 32	CP0087B0
VM1- 34	CP3085A0	VF1- 34	CP0100A0	VM2- 34	CP3085B0	VF2- 34	CP0100B0
VM1- 35.5	CP3649A0	VF1- 35.5	CP0788A0	VM2- 35.5	CP3649B0	VF2- 35.5	CP0788B0
VM1- 40	CP3060A0	VF1- 40	CP0101A0	VM2- 40	CP3060B0	VF2- 40	CP0101B0
VM1- 45	CP3086A0	VF1- 45	CP0102A0	VM2- 45	CP3086B0	VF2- 45	CP0102B0
VM1- 47	CP3650A0	VF1- 47	CP0199A0	VM2- 47	CP3650B0	VF2- 47	CP0199B0
VM1- 50	CP3064A0	VF1- 50	CP0072A0	VM2- 50	CP3064B0	VF2- 50	CP0072B0
VM1- 53	CP3087A0	VF1- 53	CP0103A0	VM2- 53	CP3087B0	VF2- 53	CP0103B0
VM1- 55	CP3651A0	VF1- 55	CP0789A0	VM2- 55	CP3651B0	VF2- 55	CP0789B0
VM1- 56	CP3652A0	VF1- 56	CP0790A0	VM2- 56	CP3652B0	VF2- 56	CP0790B0
VM1- 60	CP3088A0	VF1- 60	CP0104A0	VM2- 60	CP3088B0	VF2- 60	CP0104B0
VM1- 63	CP3089A0	VF1- 63	CP0105A0	VM2- 63	CP3089B0	VF2- 63	CP0105B0
VM1- 64	CP3059A0	VF1- 64	CP0067A0	VM2- 64	CP3090B0	VF2- 64	CP0106B0
VM1- 67	CP3091A0	VF1- 67	CP0107A0	VM2- 67	CP3091B0	VF2- 67	CP0791B0
VM1- 70	CP3051A0	VF1- 70	CP0029A1	VM2- 70	CP3051B0	VF2- 70	CP0059B0
VM1- 71	CP3653A0	VF1- 71	CP0792A0	VM2- 71	CP3653B0	VF2- 71	CP0793B0
VM1- 75	CP3092A0	VF1- 75	CP0109A0	VM2- 75	CP3092B0	VF2- 75	CP0108B0
VM1- 80	CP3007A0	VF1- 80	CP0055A0	VM2- 80	CP3093B0	VF2- 80	CP0009B1
VM1- 85	CP3094A0	VF1- 85	CP0110A0	VM2- 85	CP3094B0	VF2- 85	CP0794B0
VM1- 90	CP3095A0	VF1- 90	CP0111A0	VM2- 90	CP3095B0	VF2- 90	CP0313B0
VM1- 92	CP3675A0	VF1- 92	CP0846A0	VM2- 92	CP3675B0	VF2- 92	CP0847B0
VM1- 95	CP3096A0	VF1- 95	CP0113A0	VM2- 95	CP3096B0	VF2- 95	CP0112B0
VM1-100	CP3008A0	VF1- 100	CP0114A0	VM2-100	CP3008B0	VF2- 100	CP0010B1

V99F TYPE PACKINGS FOR BOTH PISTON AND ROD SEALS (EQUIVALENT TO JIS B 2403)

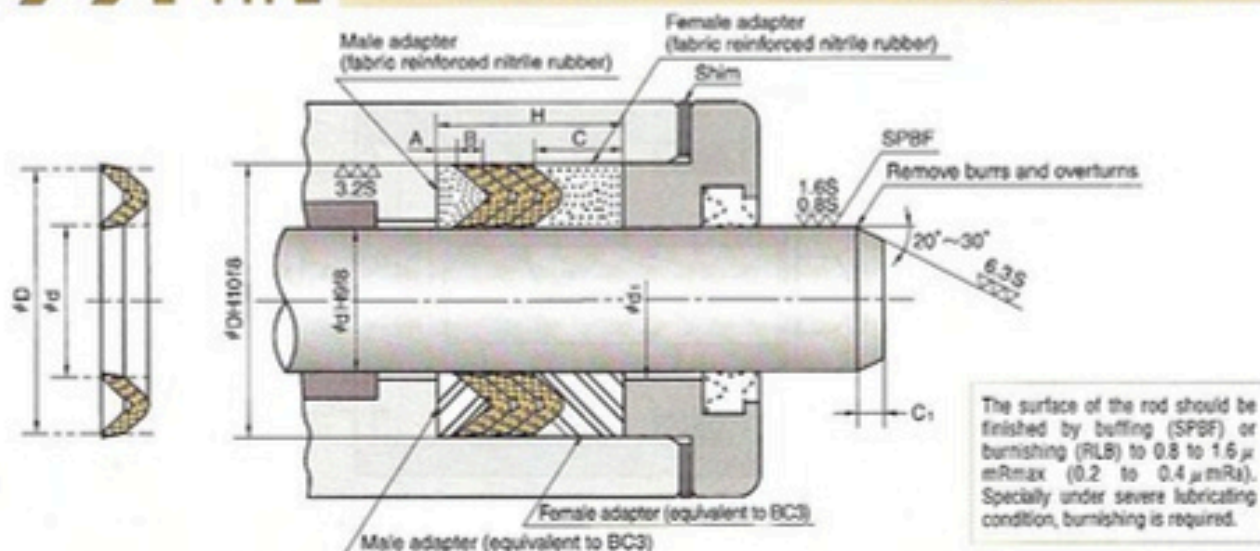

Nominal Number	Nominal Size of Packing			NOK Part Number	Adapter size		Installation length H			C_1	ϕd_1	ϕD_1
	d	D	B		A	C	Number of packings					
							3	4	5			
F 105	105	125	5 $\pm_{-0.05}^{+0.05}$	CV0928C0	10	28	33	38	5	d+2	D-2	
F 106	106	126		CV0940C0								
F 112	112	132		CV0967C0								
F 118	118	138		CV0990C0								
F 120	120	140		CV0994C0								
F 125	125	150		CV1018C0								
F 132	132	157		CV1054C0								
F 135	135	160		CV1063C0								
F 140	140	165		CV1088C0								
F 145	145	170		CV1117C0								
F 150	150	175	CV1144C0	12.5	33.5	39.5	45.5	6.5	d+2	D-2		
F 155	155	180	CV1177C0									
F 160	160	185	CV1184C0									
F 165	165	190	CV1204C0									
F 170	170	195	CV1216C0									
F 175	175	200	CV1236C0									
F 180	180	205	CV1261C0									
F 190	190	215	CV1287C0									
F 199	199	224	CV1309C0									
F 200	200	225	CV1316C0									
F 212	212	237	CV1351C0	3	40	47	54	7.5	d+3	D-3		
F 224	224	249	CV1385C0									
F 225	225	250	CV1393C0									
F 236	236	261	CV1417C0									
F 250	250	275	CV1446C0									
F 265	265	297	CV1487C0									
F 280	280	312	CV1513C0									
F 300	300	332	CV1540C0									
F 315	315	347	CV1570C0									
F 335	335	367	CV1593C0									
F 355	355	387	CV1608C0	16	47	55	63	10	d+3	D-3		
F 375	375	407	CV1631A0									
F 400	400	432	CV1642C0									
F 425	425	457	CV1665C0									
F 450	450	482	CV1889C0									
F 475	475	507	CV1681C0									
F 500	500	532	CV1692C0									
F 530	530	570	CV1701C0									
F 560	560	600	CV1890C0									
F 600	600	640	CV1827C0									
F 630	630	670	CV1729C0	20	47	55	63	10	d+3	D-3		

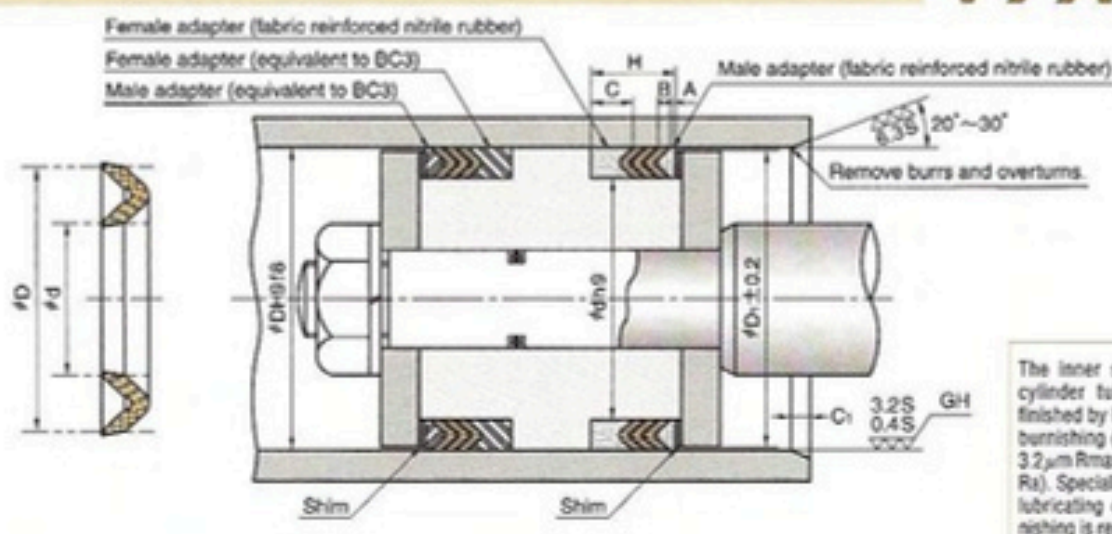

Fabric reinforced nitrile rubber adapter				Metal (equivalent to BC3) adapter			
Male		Female		Male		Female	
Nominal number	NOK Part Number	Nominal number	NOK Part Number	Nominal number	NOK Part Number	Nominal number	NOK Part Number
VM1-105	CP3097A0	VF1-105	CP0116A0	VM2-105	CP3097B0	VF2-105	CP0115B0
VM1-106	CP3098A0	VF1-106	CP0117A0	VM2-106	CP3098B0	VF2-106	CP0795B0
VM1-112	CP3099A0	VF1-112	CP0118A0	VM2-112	CP3099B0	VF2-112	CP0796B0
VM1-118	CP3655A0	VF1-118	CP0848A0	VM2-118	CP3655B0	VF2-118	CP0797B0
VM1-120	CP3100A0	VF1-120	CP0119A0	VM2-120	CP3100B0	VF2-120	CP0120B0
VM1-125	CP3101A0	VF1-125	CP0121A0	VM2-125	CP3101B0	VF2-125	CP0011B1
VM1-132	CP3656A0	VF1-132	CP0798A0	VM2-132	CP3656B0	VF2-132	CP0799B0
VM1-135	CP3343A0	VF1-135	CP0800A0	VM2-135	CP3343B0	VF2-135	CP0402B0
VM1-140	CP3102A0	VF1-140	CP0211A0	VM2-140	CP3102B0	VF2-140	CP0122B0
VM1-145	CP3103A0	VF1-145	CP0123A0	VM2-145	CP3010B0	VF2-145	CP0012B1
VM1-150	CP3104A0	VF1-150	CP0124A0	VM2-150	CP3104B0	VF2-150	CP0438B0
VM1-155	CP3105A0	VF1-155	CP0125A0	VM2-155	CP3105B0	VF2-155	CP0801B0
VM1-160	CP3039A0	VF1-160	CP0071A0	VM2-160	CP3039B0	VF2-160	CP0126B0
VM1-165	CP3025A0	VF1-165	CP0802A0	VM2-165	CP3025B0	VF2-165	CP0463B0
VM1-170	CP3657A0	VF1-170	CP0803A0	VM2-170	CP3657B0	VF2-170	CP0013B1
VM1-175	CP3061A0	VF1-175	CP0068A0	VM2-175	CP3061B0	VF2-175	CP0638B0
VM1-180	CP3013A0	VF1-180	CP0804A0	VM2-180	CP3013B0	VF2-180	CP0015B1
VM1-190	CP3413A0	VF1-190	CP0805A0	VM2-190	CP3413B0	VF2-190	CP0806B0
VM1-199	CP3069A0	VF1-199	CP0807A0	VM2-199	CP3069B0	VF2-199	CP0078B0
VM1-200	CP3106A0	VF1-200	CP0127A0	VM2-200	CP3106B0	VF2-200	CP0128B0
VM1-212	CP3676A0	VF1-212	CP0062A0	VM2-212	CP3676B0	VF2-212	CP0524B0
VM1-224	CP3658A0	VF1-224	CP0808A0	VM2-224	CP3658B0	VF2-224	CP0809B0
VM1-225	CP3677A0	VF1-225	CP0070A0	VM2-225	CP3677B0	VF2-225	CP0539B1
VM1-236	CP3107A0	VF1-236	CP0810A0	VM2-236	CP3107B0	VF2-236	CP0129B0
VM1-250	CP3062A0	VF1-250	CP0069A0	VM2-250	CP3062B0	VF2-250	CP0563B1
VM1-265	CP3108A0	VF1-265	CP0130A0	VM2-265	CP3108B0	VF2-265	CP0583B1
VM1-280	CP3057A0	VF1-280	CP0065A0	VM2-280	CP3057B0	VF2-280	CP0595B1
VM1-300	CP3048A0	VF1-300	CP0056A0	VM2-300	CP3048B0	VF2-300	CP0612B1
VM1-315	CP3015A0	VF1-315	CP0811A0	VM2-315	CP3015B0	VF2-315	CP0017B1
VM1-335	CP3109A0	VF1-335	CP0131A0	VM2-335	CP3109B0	VF2-335	CP0812B0
VM1-355	CP3524A0	VF1-355	CP0813A0	VM2-355	CP3524B0	VF2-355	CP0636B1
VM1-375	CP3016A0	VF1-375	CP0814A0	VM2-375	CP3016B0	VF2-375	CP0018B1
VM1-400	CP3045A0	VF1-400	CP0815A0	VM2-400	CP3045B0	VF2-400	CP0052B0
VM1-425	CP3659A0	VF1-425	CP0849A0	VM2-425	CP3659B0	VF2-425	CP0820B0
VM1-450	CP3660A0	VF1-450	CP0850A0	VM2-450	CP3660B0	VF2-450	CP0816B0
VM1-475	CP3556A0	VF1-475	CP0671A0	VM2-475	CP3556B0	VF2-475	CP0851B0
VM1-500	CP3661A0	VF1-500	CP0817A0	VM2-500	CP3661B0	VF2-500	CP0818B0
VM1-530	CP3662A0	VF1-530	CP0819A0	VM2-530	CP3662B0	VF2-530	CP0852B0
VM1-560	CP3110A0	VF1-560	CP0132A0	VM2-560	CP3110B0	VF2-560	CP0133B0
VM1-600	CP3040A0	VF1-600	CP0853A0	VM2-600	CP3040B0	VF2-600	CP0046B0
VM1-630	CP3678A0	VF1-630	CP0854A0	VM2-630	CP3678B0	VF2-630	CP0855B0

F

V96H_{TYPE}

PACKINGS FOR BOTH PISTON AND ROD SEALS
NITRILE RUBBER (NBR)



● Please designate NOK Part number and type & size on your order.

(1) In case of V packing only

VP H 6.3 CV0001F0
 V packing Nominal number Part Number

(2) In case of adapter

VM1-6.3 CP3673A0
 Nominal number Part Number

(3) In case of the combination of V packing and adapter
(In this case, the part number does not need to be designated.)

VPH 6.3 - 3 1 1
 V packing Nominal number Number of V packings in use Type of male adapter Type of female adapter
 1... fabric reinforced nitrile rubber 1... fabric reinforced nitrile rubber
 2... equivalent to BC3 2... equivalent to BC3

● Please check the application range on pages D-2 and 3 before selecting the type.

Material	V packing only	NOK A505
	Adapter	Type 1 : NOK 21AG (fabric reinforced nitrile rubber) Type 2 : equivalent to BC3 (bronze)
Special order	If you require packings having dimensions not listed in this dimension table or made of materials (rubber) other than the standard, new mold might be necessary. In this case, we will submit to you our quotation for such packings.	
Caution for application	1. After fitting into the groove, no initial tightening is necessary. 2. About the material of adapter If the operation pressure exceeds 8MPa, use the material of BC equivalent.	

V96H TYPE PACKINGS FOR BOTH PISTON AND ROD SEALS (EQUIVALENT TO JIS B 2403)

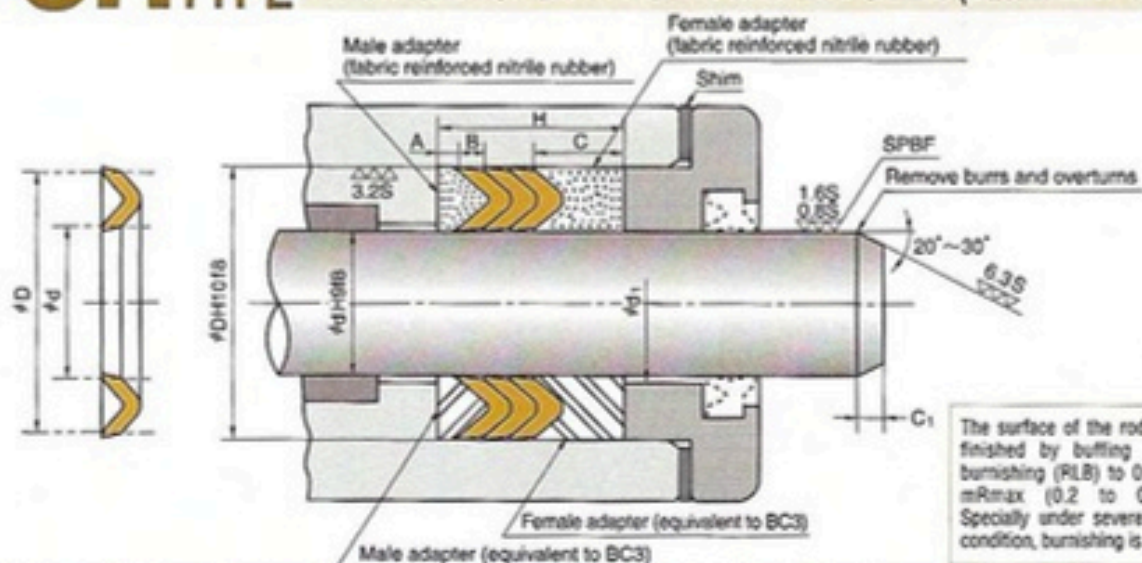

Nominal Number	Nominal Size of Packing			NOK Part Number	Adapter size		Installation length H			C ₁	d ₁	D ₁
	d	D	B		A	C	Number of packings					
H 6.3	6.3	16.3	2.5 ± 0.3	CV0001F0	5	15.5	18	20.5	2.5	2	d+1	D-1
H 7.1	7.1	17.1		CV0005F0								
H 8	8	18		CV0010F0								
H 9	9	19		CV0018F0								
H 10	10	20		CV0027F0								
H 11.2	11.2	21.2		CV0037F0								
H 12.5	12.5	22.5		CV0046F0								
H 14	14	24		CV0056F0								
H 16	16	26		CV0084F0								
H 15	15	28		CV0071F0								
H 18	18	31	CV0109F0	6.5	18.5	21.5	24.5	3.5	3	d+1	D-1	
H 18.5	18.5	31.5	CV0114F0									
H 20	20	33	CV0132F0									
H 22.4	22.4	35.4	CV0163F0									
H 25	25	38	CV0176F0									
H 27	27	40	CV0220F0									
H 28	28	41	CV0231F0									
H 31.5	31.5	44.5	CV0280F0									
H 32	32	45	CV0293F0									
H 34	34	50	CV1893F0									
H 35.5	35.5	51.5	CV0338F0	8	21.5	25	28.5	4	3	d+1	D-1	
H 40	40	56	CV0369F0									
H 45	45	61	CV0417F0									
H 47	47	63	CV0440F0									
H 50	50	66	CV0456F0									
H 53	53	69	CV0502F0									
H 55	55	71	CV0517F0									
H 56	56	72	CV0538F0									
H 60	60	76	CV0561F0									
H 63	63	79	CV0598F0									
H 64	64	80	CV0619F0	10	25	29	33	5	3	d+2	D-2	
H 67	67	87	CV0650F0									
H 70	70	90	CV0673F0									
H 71	71	91	CV0700F1									
H 75	75	95	CV0710F0									
H 80	80	100	CV0754F0									
H 85	85	105	CV0792F0									
H 90	90	110	CV0826F0									
H 92	92	112	CV0849F0									
H 95	95	115	CV0854F0									

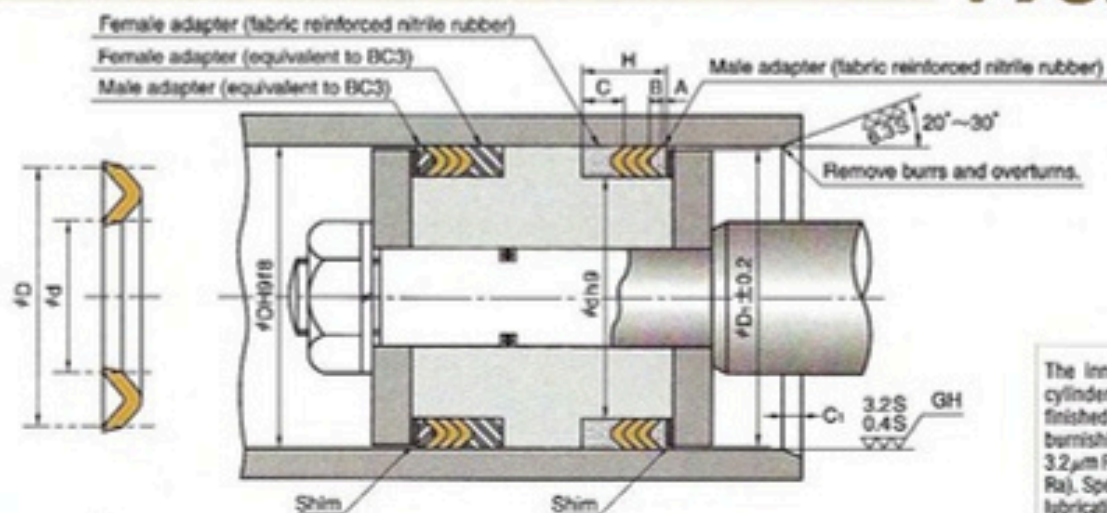

The inner surface of the cylinder tube should be finished by honing (GH) or burnishing (RLB) to 0.4 to 3.2 μm Rmax (0.1 to 0.8 μm Ra). Specially under severe lubricating condition, burnishing is required.

Fabric reinforced nitrile rubber adapter				Metal (equivalent to BC3) adapter			
Male		Female		Male		Female	
Nominal number	NOK Part Number	Nominal number	NOK Part Number	Nominal number	NOK Part Number	Nominal number	NOK Part Number
VM1- 6.3	CP3673A0	VF1- 6.3	CP0839A0	VM2- 6.3	CP3673B0	VF2- 6.3	CP0840B0
VM1- 7.1	CP3044A0	VF1- 7.1	CP0051A0	VM2- 7.1	CP3044B0	VF2- 7.1	CP0841B0
VM1- 8	CP3081A0	VF1- 8	CP0775A0	VM2- 8	CP3081B0	VF2- 8	CP0091B0
VM1- 9	CP3646A0	VF1- 9	CP0842A0	VM2- 9	CP3646B0	VF2- 9	CP0776B0
VM1- 10	CP3080A0	VF1- 10	CP0777A0	VM2- 10	CP3080B0	VF2- 10	CP0778B0
VM1- 11.2	CP3674A0	VF1- 11.2	CP0843A0	VM2- 11.2	CP3674B0	VF2- 11.2	CP0844B0
VM1- 12.5	CP3077A0	VF1- 12.5	CP0821A0	VM2- 12.5	CP3077B0	VF2- 12.5	CP0086B0
VM1- 14	CP3055A0	VF1- 14	CP0063A0	VM2- 14	CP3055B0	VF2- 14	CP0779B0
VM1- 16	CP3247A0	VF1- 16	CP0780A0	VM2- 16	CP3247B1	VF2- 16	CP0781B0
VM1- 15	CP3082A0	VF1- 15	CP0092A0	VM2- 15	CP3082B0	VF2- 15	CP0093B0
VM1- 18	CP3115A0	VF1- 18	CP0782A0	VM2- 18	CP3115B0	VF2- 18	CP0137B0
VM1- 18.5	CP3647A0	VF1- 18.5	CP0845A0	VM2- 18.5	CP3647B0	VF2- 18.5	CP0783B0
VM1- 20	CP3056A0	VF1- 20	CP0064A0	VM2- 20	CP3056B0	VF2- 20	CP0094B0
VM1- 22.4	CP3083A0	VF1- 22.4	CP0095A0	VM2- 22.4	CP3083B0	VF2- 22.4	CP0784B0
VM1- 25	CP3084A0	VF1- 25	CP0097A0	VM2- 25	CP3084B0	VF2- 25	CP0096B0
VM1- 27	CP3648A0	VF1- 27	CP0785A0	VM2- 27	CP3648B0	VF2- 27	CP0786B0
VM1- 28	CP3070A0	VF1- 28	CP0098A0	VM2- 28	CP3070B0	VF2- 28	CP0079B0
VM1- 31.5	CP3053A0	VF1- 31.5	CP0787A0	VM2- 31.5	CP3053B0	VF2- 31.5	CP0061B0
VM1- 32	CP3078A0	VF1- 32	CP0099A0	VM2- 32	CP3078B0	VF2- 32	CP0087B0
VM1- 34	CP3085A0	VF1- 34	CP0100A0	VM2- 34	CP3085B0	VF2- 34	CP0100B0
VM1- 35.5	CP3649A0	VF1- 35.5	CP0788A0	VM2- 35.5	CP3649B0	VF2- 35.5	CP0788B0
VM1- 40	CP3060A0	VF1- 40	CP0101A0	VM2- 40	CP3060B0	VF2- 40	CP0101B0
VM1- 45	CP3086A0	VF1- 45	CP0102A0	VM2- 45	CP3086B0	VF2- 45	CP0102B0
VM1- 47	CP3650A0	VF1- 47	CP0199A0	VM2- 47	CP3650B0	VF2- 47	CP0199B0
VM1- 50	CP3064A0	VF1- 50	CP0072A0	VM2- 50	CP3064B0	VF2- 50	CP0072B0
VM1- 53	CP3087A0	VF1- 53	CP0103A0	VM2- 53	CP3087B0	VF2- 53	CP0103B0
VM1- 55	CP3651A0	VF1- 55	CP0789A0	VM2- 55	CP3651B0	VF2- 55	CP0789B0
VM1- 56	CP3652A0	VF1- 56	CP0790A0	VM2- 56	CP3652B0	VF2- 56	CP0790B0
VM1- 60	CP3088A0	VF1- 60	CP0104A0	VM2- 60	CP3088B0	VF2- 60	CP0104B0
VM1- 63	CP3089A0	VF1- 63	CP0105A0	VM2- 63	CP3089B0	VF2- 63	CP0105B0
VM1- 64	CP3059A0	VF1- 64	CP0067A0	VM2- 64	CP3090B0	VF2- 64	CP0106B0
VM1- 67	CP3091A0	VF1- 67	CP0107A0	VM2- 67	CP3091B0	VF2- 67	CP0791B0
VM1- 70	CP3051A0	VF1- 70	CP0029A1	VM2- 70	CP3051B0	VF2- 70	CP0059B0
VM1- 71	CP3653A0	VF1- 71	CP0792A0	VM2- 71	CP3653B0	VF2- 71	CP0793B0
VM1- 75	CP3092A0	VF1- 75	CP0109A0	VM2- 75	CP3092B0	VF2- 75	CP0108B0
VM1- 80	CP3007A0	VF1- 80	CP0055A0	VM2- 80	CP3093B0	VF2- 80	CP0009B1
VM1- 85	CP3094A0	VF1- 85	CP0110A0	VM2- 85	CP3094B0	VF2- 85	CP0794B0
VM1- 90	CP3095A0	VF1- 90	CP0111A0	VM2- 90	CP3095B0	VF2- 90	CP0313B0
VM1- 92	CP3675A0	VF1- 92	CP0846A0	VM2- 92	CP3675B0	VF2- 92	CP0847B0
VM1- 95	CP3096A0	VF1- 95	CP0113A0	VM2- 95	CP3096B0	VF2- 95	CP0112B0

V96H TYPE PACKINGS FOR BOTH PISTON AND ROD SEALS (EQUIVALENT TO JIS B 2403)

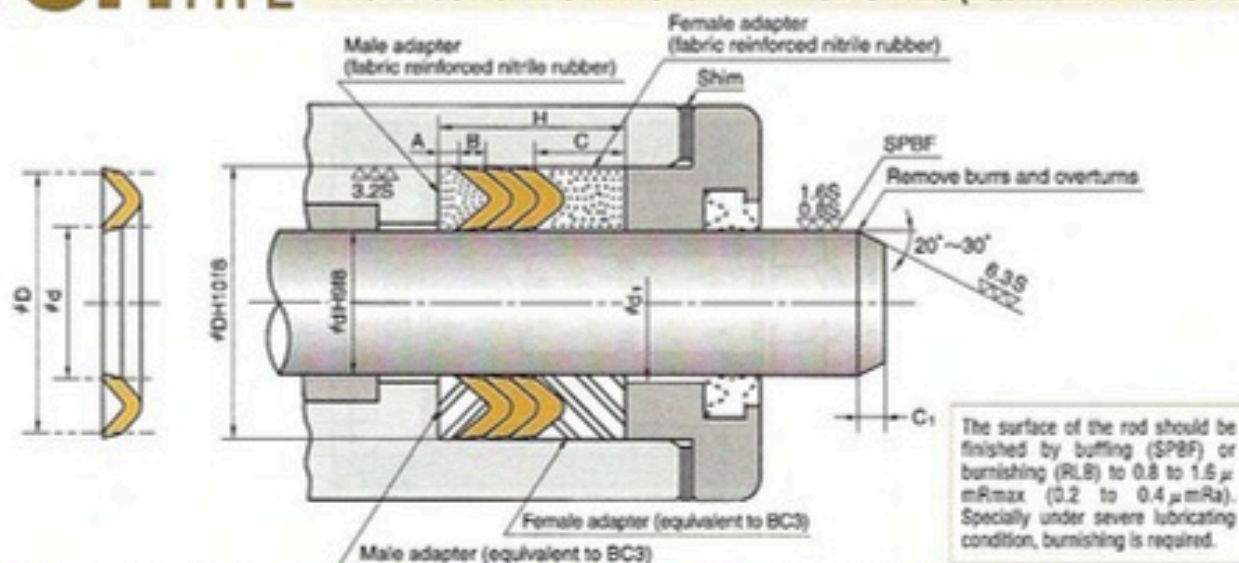

Nominal Number	Nominal Size of Packing			NOK Part Number	Adapter size		Installation length H			C ₁	φd ₁	φD ₁
	d	D	B		A	C	Number of packings					
H 100	100	120	4.0 ± 0.3	CV0872F0	10	25	29	33	5	d+2	D-2	
H 105	105	125		CV0927F0								
H 106	106	126		CV0939F0								
H 112	112	132		CV0966F0								
H 118	118	138		CV1896F0								
H 120	120	140		CV0993F0								
H 125	125	150		CV1017F0								
H 132	132	157		CV1053F0								
H 135	135	160		CV1062F0								
H 140	140	165		CV1087F0								
H 145	145	170	CV1116F0	3	12.5	30.5	35.5	40.5	6.5	d+2	D-2	
H 150	150	175	CV1143F0									
H 155	155	180	CV1176F0									
H 160	160	185	CV1183C0									
H 165	165	190	CV1203F0									
H 170	170	195	CV1215F0									
H 175	175	200	CV1235F0									
H 180	180	205	CV1260F0									
H 190	190	215	CV1286F0									
H 199	199	224	CV1308F0									
H 200	200	225	CV1315F0	6 ± 0.4	16	37	43	49	7.5	d+3	D-3	
H 212	212	237	CV1350F0									
H 224	224	249	CV1384F0									
H 225	225	250	CV1392F0									
H 236	236	261	CV1416F0									
H 250	250	275	CV1445F0									
H 265	265	297	CV1486F0									
H 280	280	312	CV1512F0									
H 300	300	332	CV1539F0									

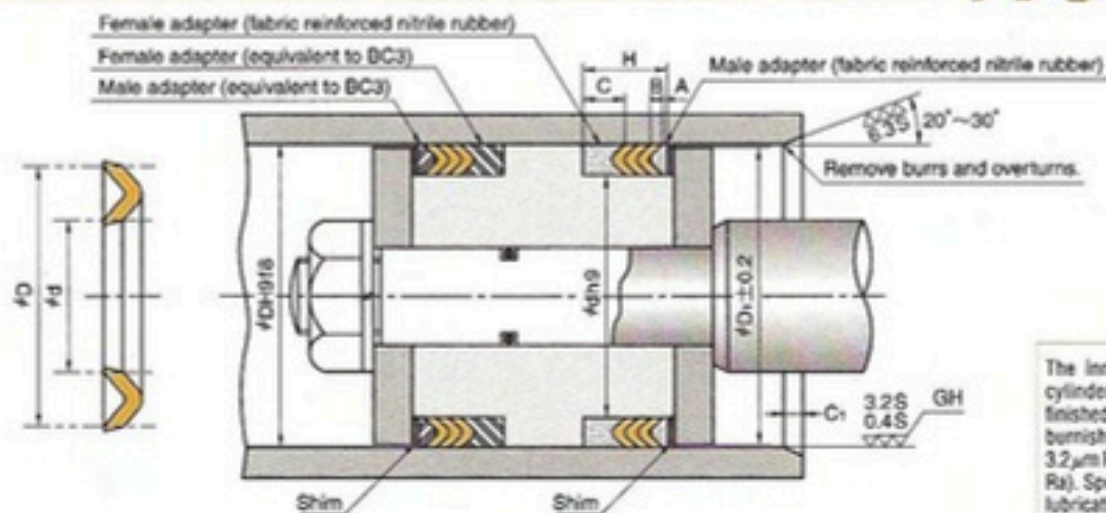

The inner surface of the cylinder tube should be finished by honing (GH) or burnishing (RLB) to 0.4 to 3.2 μm Rmax (0.1 to 0.8 μm Ra). Specially under severe lubricating condition, burnishing is required.

Fabric reinforced nitrile rubber adapter				Metal (equivalent to BC3) adapter			
Male		Female		Male		Female	
Nominal number	NOK Part Number	Nominal number	NOK Part Number	Nominal number	NOK Part Number	Nominal number	NOK Part Number
VM1-100	CP3008A0	VF1-100	CP0114A0	VM2-100	CP3008B0	VF2-100	CP0010B1
VM1-105	CP3097A0	VF1-105	CP0116A0	VM2-105	CP3097B0	VF2-105	CP0115B0
VM1-106	CP3098A0	VF1-106	CP0117A0	VM2-106	CP3098B0	VF2-106	CP0795B0
VM1-112	CP3099A0	VF1-112	CP0118A0	VM2-112	CP3099B0	VF2-112	CP0796B0
VM1-118	CP3655A0	VF1-118	CP0848A0	VM2-118	CP3655B0	VF2-118	CP0797B0
VM1-120	CP3100A0	VF1-120	CP0119A0	VM2-120	CP3100B0	VF2-120	CP0120B0
VM1-125	CP3101A0	VF1-125	CP0121A0	VM2-125	CP3101B0	VF2-125	CP0011B1
VM1-132	CP3656A0	VF1-132	CP0798A0	VM2-132	CP3656B0	VF2-132	CP0799B0
VM1-135	CP3343A0	VF1-135	CP0800A0	VM2-135	CP3343B0	VF2-135	CP0402B0
VM1-140	CP3102A0	VF1-140	CP0211A0	VM2-140	CP3102B0	VF2-140	CP0122B0
VM1-145	CP3103A0	VF1-145	CP0123A0	VM2-145	CP3010B0	VF2-145	CP0012B1
VM1-150	CP3104A0	VF1-150	CP0124A0	VM2-150	CP3104B0	VF2-150	CP0438B0
VM1-155	CP3105A0	VF1-155	CP0125A0	VM2-155	CP3105B0	VF2-155	CP0801B0
VM1-160	CP3039A0	VF1-160	CP0071A0	VM2-160	CP3039B0	VF2-160	CP0126B0
VM1-165	CP3025A0	VF1-165	CP0802A0	VM2-165	CP3025B0	VF2-165	CP0463B0
VM1-170	CP3657A0	VF1-170	CP0803A0	VM2-170	CP3657B0	VF2-170	CP0013B1
VM1-175	CP3061A0	VF1-175	CP0068A0	VM2-175	CP3061B0	VF2-175	CP0638B0
VM1-180	CP3013A0	VF1-180	CP0804A0	VM2-180	CP3013B0	VF2-180	CP0015B1
VM1-190	CP3413A0	VF1-190	CP0805A0	VM2-190	CP3413B0	VF2-190	CP0806B0
VM1-199	CP3069A0	VF1-199	CP0807A0	VM2-199	CP3069B0	VF2-199	CP0078B0
VM1-200	CP3106A0	VF1-200	CP0127A0	VM2-200	CP3106B0	VF2-200	CP0128B0
VM1-212	CP3676A0	VF1-212	CP0062A0	VM2-212	CP3676B0	VF2-212	CP0524B0
VM1-224	CP3658A0	VF1-224	CP0808A0	VM2-224	CP3658B0	VF2-224	CP0809B0
VM1-225	CP3677A0	VF1-225	CP0070A0	VM2-225	CP3677B0	VF2-225	CP0539B1
VM1-236	CP3107A0	VF1-236	CP0810A0	VM2-236	CP3107B0	VF2-236	CP0129B0
VM1-250	CP3062A0	VF1-250	CP0069A0	VM2-250	CP3062B0	VF2-250	CP0563B1
VM1-265	CP3108A0	VF1-265	CP0130A0	VM2-265	CP3108B0	VF2-265	CP0583B1
VM1-280	CP3057A0	VF1-280	CP0065A0	VM2-280	CP3057B0	VF2-280	CP0595B1
VM1-300	CP3048A0	VF1-300	CP0056A0	VM2-300	CP3048B0	VF2-300	CP0612B1

DKI_{TYPE}

DUST SEALS FOR RECIPROCAL MOVEMENT
NOXLAN (AU)



- Please designate NOK Part number and type & size on your order.

(Example) • Type Dimensions DKI 6.3 16 5 7

Type Sign

Nominal Size of Dust Seal
described in order of inner diameter(d), outer diameter(D), thickness(t)
and height(h)

• Part Number FD0064A0

- Please check the application range on pages D-2 and 3 before selecting the type.

Material	NOK U801 + Metal seal ring (SPCC)
-----------------	-----------------------------------

DKI_{TYPE} DUST SEALS FOR RECIPROCAL MOVEMENT

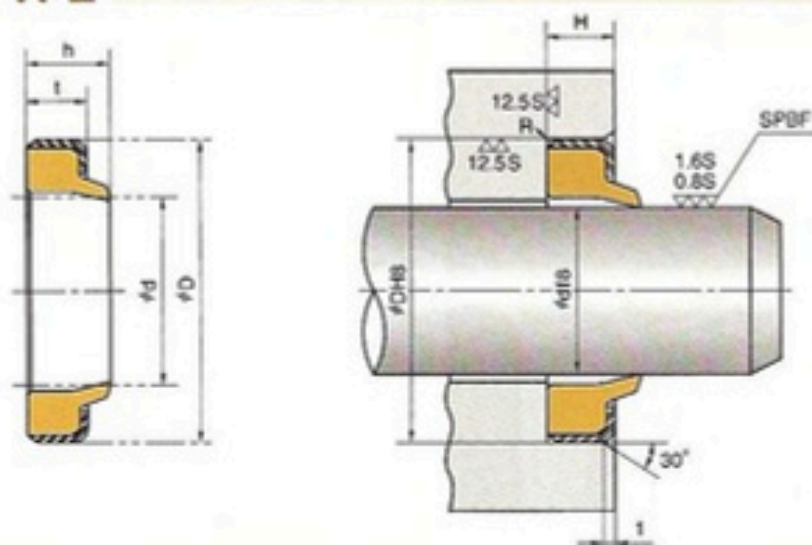

R = 0.3 or below

The surface of the rod should be finished by buffing (SPBF) or burnishing (RLB) to 0.8 to 1.6 μ m Rmax (0.2 to 0.4 μ m Ra). Specially under severe lubricating condition, burnishing is required.

Nominal Size of Dust Seal				Housing dimensions			NOK Part Number
d	D	t	h	ϕd	ϕD	H	
6.3	16	5	7	6.3	16	5 $\frac{H}{11}$	FD0064A0
7.1	17			7.1	17		FD0095A0
8	18			8	18		FD0142A0
9	19			9	19		FD0199A0
10	20			10	20		FD0258A0
11.2	21			11.2	21		FD0332A0
12.5	23			12.5	23		FD0412A0
14	24			14	24		FD0513A0
15	25			15	25		FD0586A0
16	26			16	26		FD0677A0
18	30	6	9	18	30	6 $\frac{H}{11}$	FD0815A0
20	32			20	32		FD0995A0
22.4	34.4			22.4	34.4		FD1203A0
25	37			25	37		FD1301A0
27	39			27	39		FD1503A0
28	40			28	40		FD1536A0
30	42			30	42		FD1664A0
31.5	44			31.5	44		FD1803A0
32	44			32	44		FD1870A0
35	47			35	47		FD2041A0
35.5	47.5	7	10	35.5	47.5	7 $\frac{H}{11}$	FD2149A0
38	50			38	50		FD2217A0
40	52			40	52		FD2342A0
45	57			45	57		FD2633A0
47	59			47	59		FD2729A0
50	62			50	62		FD2831A0
53	67			53	67		FD2985A0
55	69			55	69		FD3033A0
56	70			56	70		FD3089A0
60	74			60	74		FD3187A0
63	77	8	11	63	77	8 $\frac{H}{11}$	FD3313A0
64	78			64	78		FD3366A0
65	79			65	79		FD3381A0
67	81			67	81		FD3447A0
70	84			70	84		FD3493A0
71	85			71	85		FD3546A0
75	89			75	89		FD3596A0
80	94			80	94		FD3720A0
85	99			85	99		FD3828A0
90	104			90	104		FD3913A0

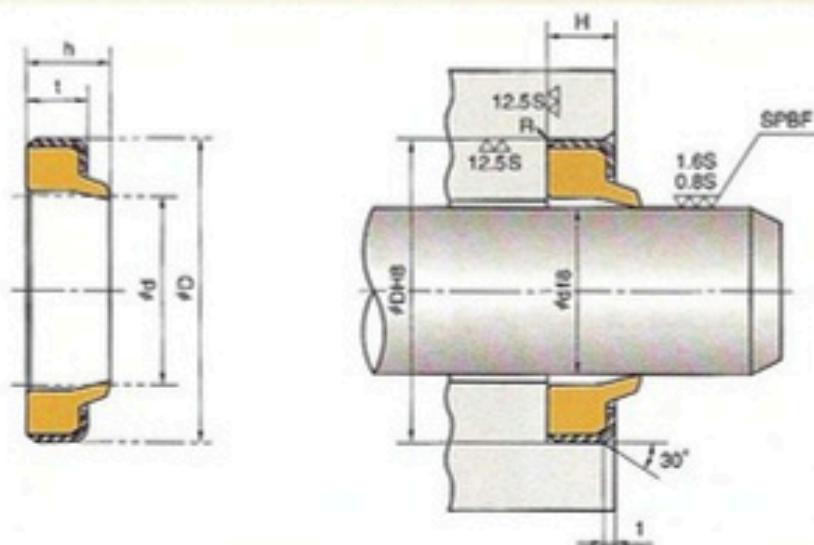

R = 0.3 or below

The surface of the rod should be finished by buffing (SPBF) or burnishing (RLS) to 0.8 to 1.6 μ mRmax (0.2 to 0.4 μ mRa). Specially under severe lubricating condition, burnishing is required.

Nominal Size of Dust Seal				Housing dimensions			NOK Part Number
d	D	t	h	#d	#D	H	
92	106	8	11	92	106	8 \pm 0.1	FD3957A0
95	109			95	109		FD3976A0
100	114			100	114		FD4046A0
105	121	9	12	105	121	9 \pm 0.1	FD4142A0
106	122			106	122		FD4168A0
108	125			108	125		FD4167E0
110	126			110	126		FD4196A0
112	128			112	128		FD4232A0
115	131			115	131		FD4272E0
118	134			118	134		FD4317A0
120	136			120	136		FD4326A0
125	141			125	141		FD4393A0
130	146			130	146		FD4438A0
132	148	10	14	132	148	10 \pm 0.1	FD4476A0
135	155			135	155		FD4492A0
140	160			140	160		FD4533A0
145	165			145	165		FD4578A0
150	170			150	170		FD4615A0
155	175			155	175		FD4663E0
160	180			160	180		FD4704A0
165	185			165	185		FD4733A0
170	190			170	190		FD4785A0
175	195			175	195		FD4839A0
180	205	12	17	180	205	12 \pm 0.1	FD4890A0
185	210			185	210		FD4941E0
190	215			190	215		FD4969A0
200	225			200	225		FD5048A0
210	235			210	235		FD5129E0
212	237			212	237		FD5151A0
220	245			220	245		FD5200A0
224	249			224	249		FD5237A0
225	250			225	250		FD5245F0
230	255			230	255		FD5277A0
236	261	16	22	236	261	16 \pm 0.1	FD5326A0
240	265			240	265		FD5336A0
245	270			245	270		FD5379E0
250	275			250	275		FD5396A0
260	285			260	285		FD5451E0
265	290			265	290		FD5480A0
280	310			280	310		FD5556A0
290	320			290	320		FD5584E0
300	330			300	330		FD5622A0

DWI TYPE DUST SEALS FOR RECIPROCAL MOVEMENT

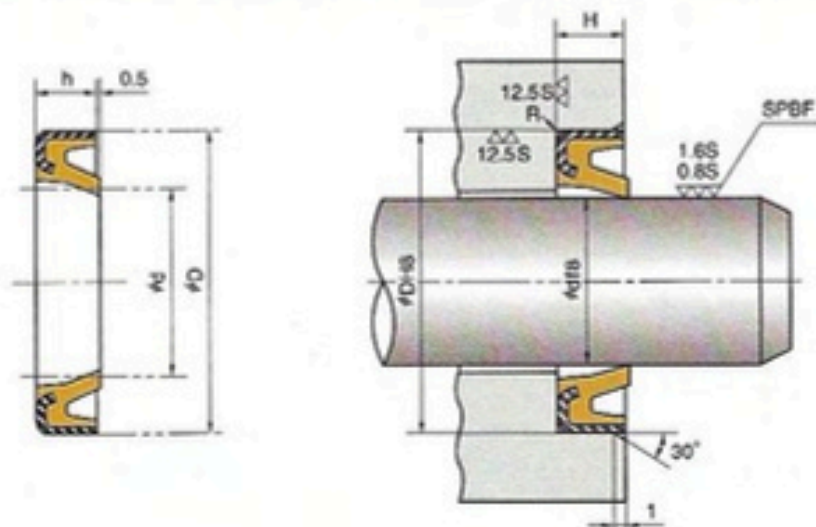

R ≤ 0.3 or below

The surface of the rod should be finished by buffing (SPBF) or burnishing (RLB) to 0.8 to 1.6 μ mRmax (0.2 to 0.4 μ mRa). Specially under severe lubricating condition, burnishing is required.

Nominal Size of Dust Seal			Housing dimensions			NOK Part Number
d	D	h	ϕd	ϕD	H	
40	52	7	40	52	7 ± 0.1	FD2342G0
45	57		45	57		FD2633H0
50	62		50	62		FD2831F0
55	69	8	55	69	8 ± 0.1	FD3033F0
60	74		60	74		FD3187H0
61	74		61	74		FD6782E0
63	77		63	77		FD3313E0
65	79		65	79		FD3381I0
70	84		70	84		FD3493I0
75	89		75	89		FD3596F0
80	94		80	94		FD3720G0
85	99		85	99		FD3828H0
90	104		90	104		FD3913F0
100	114	9	100	114	9 ± 0.1	FD4046F0
110	126		110	126		FD4196F0
120	136		120	136		FD4326F0
130	146		130	146		FD4438G0
140	160	10	140	160	10 ± 0.1	FD4533G0

F

DWIR型

DUST SEALS FOR RECIPROCAL MOVEMENT
NOXLAN (AU)



F

- Please designate NOK Part number and type & size on your order.

(Example) • Type Dimensions DWIR 25 37 6 6.9

Type Sign

Nominal Size of Dust Seal
described in order of inner diameter(d), outer diameter(D), thickness(t)
and height(h)

• Part Number FD1301G0

- Please check the application range on pages D-2 and 3 before selecting the type.

Material	NOK U801 + Metal seal ring (SPCC)
----------	-----------------------------------

DWIR_{TYPE} DUST SEALS FOR RECIPROCAL MOVEMENT

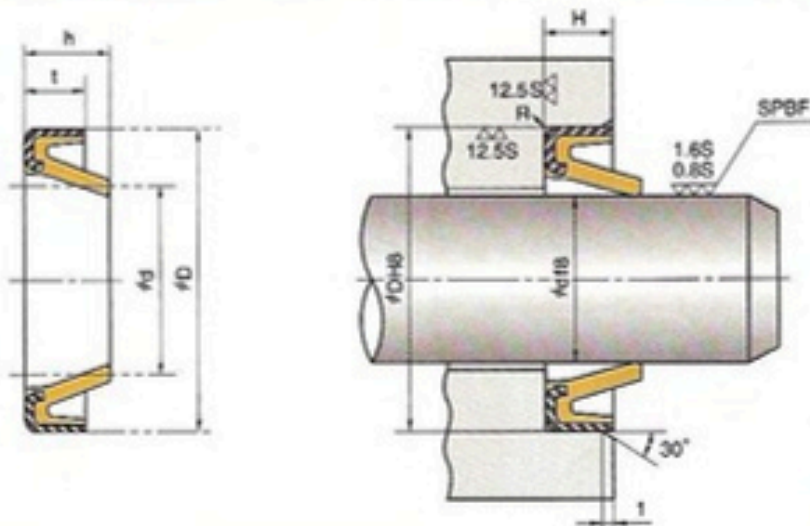

R = 0.3 or below

The surface of the rod should be finished by buffing (SPBF) or burnishing (RLB) to 0.8 to 1.6 μ mR_{max} (0.2 to 0.4 μ mRa). Specially under severe lubricating condition, burnishing is required.

Nominal Size of Dust Seal				Housing dimensions			NOK Part Number
d	D	t	h	ϕ d	ϕ D	H	
25	37	6	6.9	25	37	6 \pm 0.01	FD1301G0
30	42			30	42		FD1664 I0
35	47			35	47		FD2041 J0
40	52	7	7.9	40	52	7 \pm 0.01	FD2342H0
45	57			45	57		FD2633 J0
55	69			55	69		FD3033 I0
60	74	8	11.3	60	74	8 \pm 0.01	FD3187G0
65	79			65	79		FD3381G0
70	84			70	84		FD3493K0
75	89			75	89		FD3596 I0
80	94			80	94		FD3720K0
85	99			85	99		FD3828M0
90	104			90	104		FD3913G0
95	109			95	109		FD3976K0
100	114	9	12.3	100	114	9 \pm 0.01	FD4046G0
105	121			105	121		FD4142H0
110	126			110	126		FD4196G0
120	136			120	136		FD4326G0
130	146			130	146		FD4438H0
140	160	10	13.3	140	160	10 \pm 0.01	FD4533H0

F

DKBI_{TYPE}

DUST SEALS FOR RECIPROCAL MOVEMENT
NOXLAN (AU)



F

- Please designate NOK Part number and type & size on your order.

(Example) • Type Dimensions DKBI 20 32 6 9

Type Sign

Nominal Size of Dust Seal
described in order of inner diameter(d), outer diameter(D), thickness(t)
and height(h)

• Part Number FD0995F0

- Please check the application range on pages D-2 and 3 before selecting the type.

Material	NOK U801 + Metal seal ring (SPCC)
-----------------	-----------------------------------

DKBI TYPE DUST SEALS FOR RECIPROCAL MOVEMENT

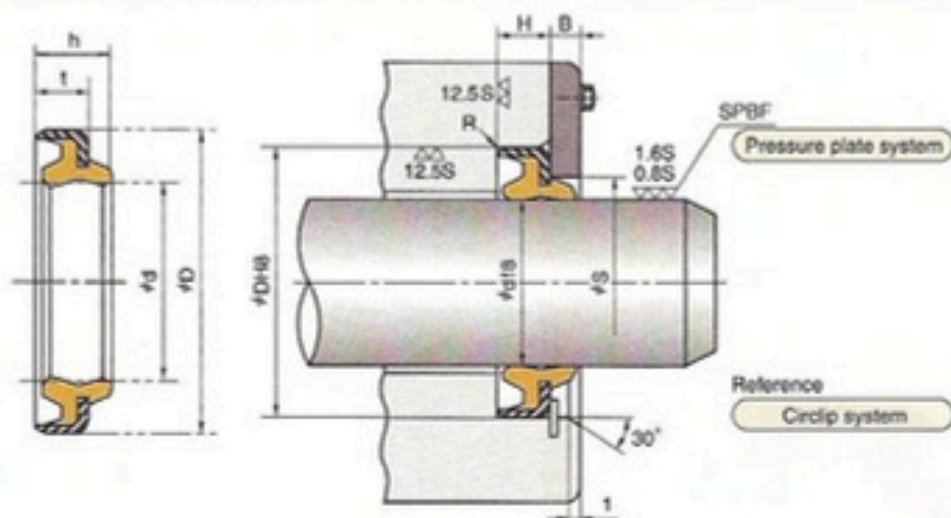

R = 0.3 or below

The surface of the rod should be finished by buffing (SPBF) or burnishing (RL/B) to 0.8 to 1.6 μm Rmax (0.2 to 0.4 μm Ra). Specially under severe lubricating condition, burnishing is required.

Nominal Size of Dust Seal				Housing dimensions					NOK Part Number
d	D	t	h	φd	φD	φS	H	B	
20	32	6	9	20	32	27	6 ±0.01	4	FD0995F0
25	37			25	37	32			FD1301E0
30	42			30	42	37			FD1664E0
32	44	7	10	32	44	39	7 ±0.01		FD1870E0
34	46			34	46	41			FD1962E1
35	47			35	47	42			FD2041E1
38	50			38	50	45			FD9940E0
40	52			40	52	47			FD2342F0
45	57			45	57	52			FD2633G0
50	62	8	11	50	62	57	8 ±0.01		FD2831E0
55	69			55	69	62			FD3033E1
60	74			60	74	67			FD3187E0
65	79			65	79	72		FD3381E0	
70	84			70	84	77		FD3493E0	
75	89			75	89	82		FD3596E0	
80	94	9	12	80	94	87	9 ±0.01	FD3720E0	
85	99			85	99	92		FD3828G0	
90	104			90	104	97		FD3913E0	
95	109			95	109	102		FD3976E0	
100	114			100	114	107		FD4046E1	
105	121			105	121	113		FD6722E0	
110	126	9	12	110	126	118	9 ±0.01	FD4196E0	
115	131			115	131	123		FD4272 I0	
120	136			120	136	128		FD4326E0	
130	146			130	146	138		FD4438F0	
140	160	10	14	140	160	150	10 ±0.01	5	FD4533E0

F

DKB_{TYPE}

DUST SEALS FOR RECIPROCAL MOVEMENT
NITRILE RUBBER (NBR)



F

- Please designate NOK Part number and type & size on your order.

(Example) • Type Dimensions DKB 14 24 5 7

Type Sign

Nominal Size of Dust Seal
described in order of inner diameter(d), outer diameter(D), thickness(t)
and height(h)

• Part Number AR0513F5

- Please check the application range on pages D-2 and 3 before selecting the type.

Material	NOK A795 + Metal seal ring (SPCC)
-----------------	-----------------------------------

DKB TYPE DUST SEALS FOR RECIPROCAL MOVEMENT

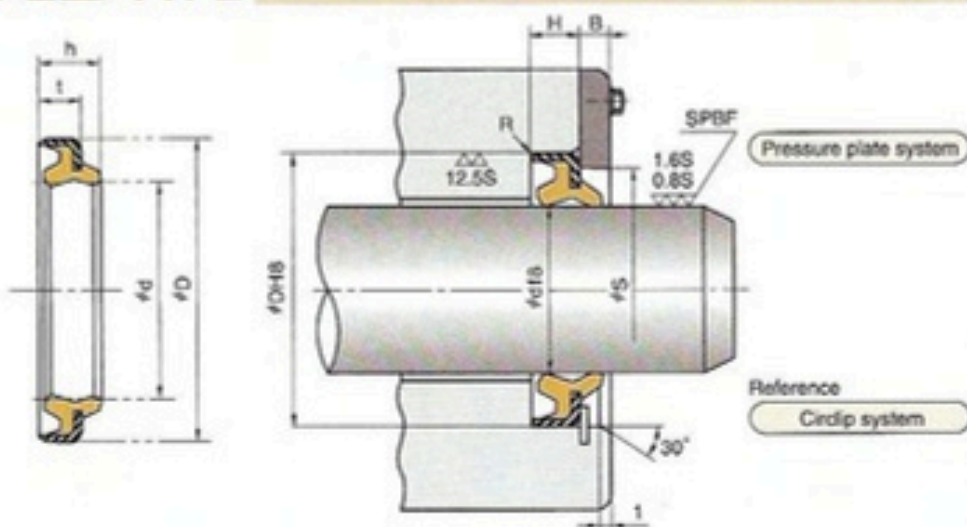

The surface of the rod should be finished by buffing (SPBF) or burnishing (RLB) to 0.8 to 1.6 μ mRmax (0.2 to 0.4 μ mRa). Specially under severe lubricating condition, burnishing is required.

Nominal Size of Dust Seal				Housing dimensions					NOK Part Number
d	D	t	h	φd	φD	φS	H	B	
14	24	5	7	14	24	19	5 \pm 0.03	4	AR0513 F5
16	26			16	26	21			AR0677 E5
18	30			18	30	25			AR0815 F5
20	32			20	32	27			AR0995 E1
22	34	6	9	22	34	29	6 \pm 0.03	4	AR1121 F5
22.4	34.4			22.4	34.4	29			AR1203 F5
25	37			25	37	32			AR1301 H5
28	40			28	40	35			AR1536 F5
30	42			30	42	37			AR1664 F5
31.5	44			31.5	44	38.5			AR1803 G5
32	44	7	10	32	44	39	7 \pm 0.03	4	AR1870 F5
35	47			35	47	42			AR2041 E5
35.5	47.5			35.5	47.5	42.5			AR2149 F5
36	48			36	48	43			BR1418 E5
40	52			40	52	47			AR2342 E5
45	57			45	57	52			AR2633 G5
50	62			50	62	57			AR2831 F5
55	69			55	69	62			AR3033 F5
56	70	8	11	56	70	63	8 \pm 0.03	4	AR3089 G5
60	74			60	74	67			AR3187 G5
63	77			63	77	70			AR3313 F5
65	79			65	79	72			AR3381 F5
70	84			70	84	77			AR3493 F5
75	89			75	89	82			AR3596 G5
80	94			80	94	87			AR3720 I5
85	99			85	99	92			AR3828 F5
90	104			90	104	97			AR3913 E0
95	109			95	109	102			AR3976 G5
100	114	100	114	107	AR4046 G5				

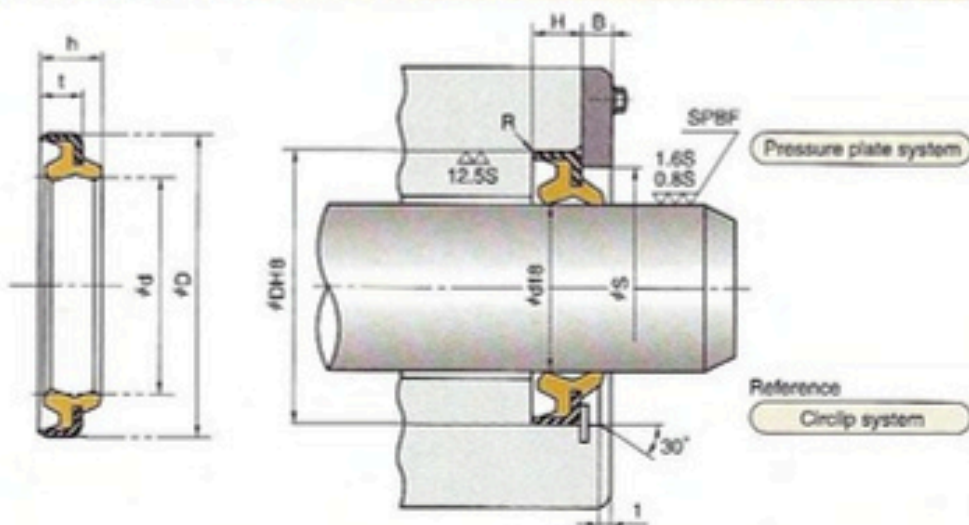

R = 0.3 or below

The surface of the rod should be finished by buffing (SPBF) or burnishing (RLB) to 0.8 to 1.6 μ m Rmax (0.2 to 0.4 μ m Ra). Specially under severe lubricating condition, burnishing is required.

Nominal Size of Dust Seal				Housing dimensions					NOK Part Number
d	D	t	h	$\varnothing d$	$\varnothing D$	$\varnothing S$	H	B	
105	121	9	12	105	121	113	9 $\frac{+0.015}{0}$	5	AR4142F5
110	126			110	126	118			AR4196F5
112	128			112	128	120			AR4232F5
120	136			120	136	128			AR4326E5
125	141			125	141	133			AR4393F5
140	160	10	14	140	160	150	10 $\frac{+0.015}{0}$		AR4533G5
145	165			145	165	155			AR4578E5
150	170			150	170	160			AR4615E5
155	175			155	175	165			AR4663E5
160	180			160	180	170			AR4704G5
170	190	12	17	170	190	180	12 $\frac{+0.015}{0}$	AR4785E5	
175	195			175	195	185		AR4839F5	
180	205			180	205	191		AR4890G5	
200	225			200	225	212		AR5048G5	
225	250			225	250	237		AR5245F5	
250	275			250	275	262	6	AR5396F5	

DKH_{TYPE}

DUST SEALS FOR RECIPROCAL MOVEMENT
NITRILE RUBBER (NBR)



- Please designate NOK Part number and type & size on your order.

(Example) • Type Dimensions DKH 10 20 5 7

Type Sign

Nominal Size of Dust Seal
described in order of inner diameter(d), outer diameter(D), thickness(t)
and height(h)

• Part Number AR0258E5

- Please check the application range on pages D-2 and 3 before selecting the type.

Material	NOK A795 + Metal seal ring (SPCC) : Outer diameter 300mm or less NOK A104 + Metal seal ring (SPCC) : Outer diameter more than 300mm
-----------------	--

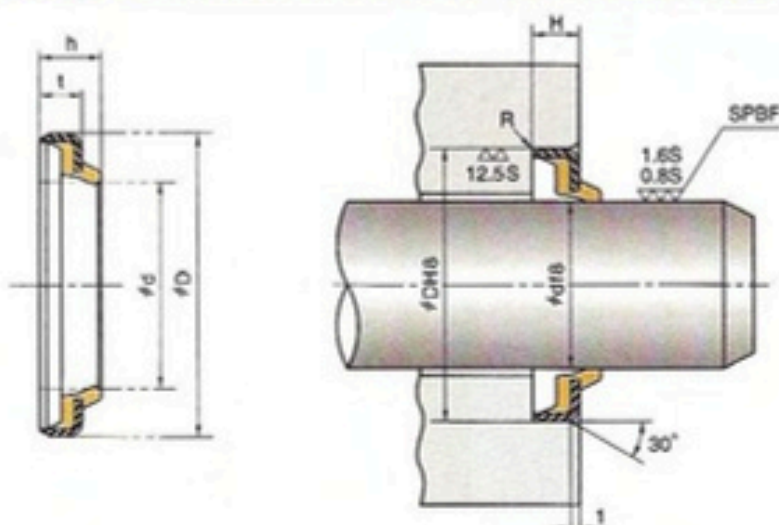

R ≈ 0.3 or below

The surface of the rod should be finished by buffing (SPBF) or burnishing (RLB) to 0.8 to 1.6 μm Rmax (0.2 to 0.4 μm Ra). Specially under severe lubricating condition, burnishing is required.

Nominal Size of Dust Seal				Housing dimensions			NOK Part Number
d	D	t	h	φd	φD	H	
10	20	5	7	10	20	5	AR0258E5
15	25			15	25		AR0586E5
20	32	6	9	20	32	6	AR0995F5
22.4	34.4			22.4	34.4		AR1203G5
25	37			25	37		AR1301F5
28	40			28	40		AR1536G5
30	42			30	42		AR1664G5
35	47			35	47		AR2041F5
35.5	47.5	7	10	35.5	47.5	7	AR2149J5
40	52			40	52		AR2342F5
45	57			45	57		AR2633J5
50	62			50	62		AR2891H5
55	69	8	11	55	69	8	AR3033G5
60	74			60	74		AR3187J5
65	79			65	79		AR3381G5
80	94			80	94		AR3720H5
85	99			85	99		AR3828G5
90	104			90	104		AR3913F5
95	109			95	109		AR3976H5
100	114			100	114		AR4046E5
105	121	9	12	105	121	9	AR4142E5
120	136			120	136		AR4326H5
130	146			130	146		AR4438E5
155	175	10	14	155	175	10	AR4663F5
210	235	12	17	210	235	12	AR5129E5
230	255			230	255		AR5277E5
240	265			240	265		AR5336E5
250	275			250	275		AR5396E5
265	290			265	290		AR5480E5
300	330	16	22	300	330	16	AR5622B5
310	340			310	340		AR5668B5
315	345			315	345		AR5685B5
330	360			330	360		AR5741B5
335	365			335	365		AR5761B5
440	480	18	24	440	480	18	AR6021B5
460	490	20	25	460	490	20	AR6073B5
470	510			470	510		AR6094B5
500	530			500	530		AR6140B5

DSI_{TYPE}

DUST SEALS FOR RECIPROCAL MOVEMENT
NOXLAN (AU)



F

- Please designate NOK Part number and type & size on your order.

(Example) • Type Dimensions DSI 6.3 14.3 4.5 6

Type Sign

Nominal Size of Dust Seal
described in order of inner diameter(d), outer diameter(D), thickness(t)
and height(h)

• Part Number FQ0000D0

- Please check the application range on pages D-2 and 3 before selecting the type.

Material	NOK U801
----------	----------

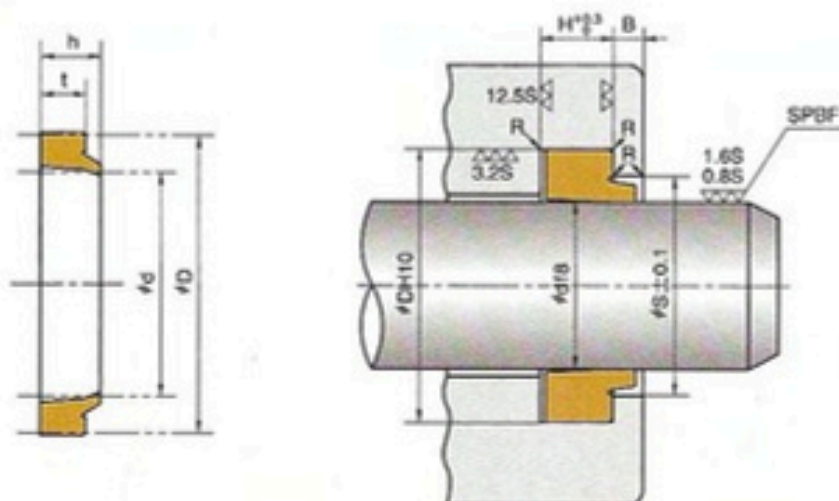

R = 0.3 or below

The surface of the rod should be finished by buffing (SPBF) or burnishing (RLB) to 0.8 to 1.6 μmRmax (0.2 to 0.4 μmRz). Specially under severe lubricating condition, burnishing is required.

Nominal Size of Dust Seal				Housing dimensions					NOK Part Number
d	D	t	h	φd	φD	φS	H	B	
6.3	14.3	4.5	6	6.3	14.3	10.3	5		FQ0000D0
8	16			FQ0002D0					
9	17			FQ0003D0					
10	18			FQ0004D0					
11.2	19.2			FQ0005D0					
12.5	20.5			FQ0006D0					
14	22			FQ0007D0					
15	23			FQ0008D0					
16	24			FQ0011D0					
18	26			FQ0013D0					
20	28			FQ0014D0					
22.4	30.4			FQ0016D0					
23.5	31.5			FQ0017D0					
25	33			FQ0018D0					
28	36	FQ0023D0							
30	38	5	6.5	30	38	34	6	2	FQ0025D0
31.5	39.5			FQ0027D0					
35	43			FQ0031D0					
35.5	43.5			FQ0034D0					
40	48			FQ0035D0					
45	53			FQ0039D0					
45.5	53.5			FQ0064D0					
50	58			FQ0041D0					
53	61			FQ0044D0					
54.5	62.5			FQ00857D0					
55	63			FQ0045D0					
56	64			FQ0048D0					
60	68			FQ0049D0					
62	70			FQ00856D0					
63	71	FQ0054D0							
65	73	FQ0057D0							
67	75	FQ0058D0							
70	80	6	8	70	80	75	7	3	FQ0059D0
71	81			FQ0062D0					
75	85			FQ0063D0					
76	86			FQ0250D0					
80	90			FQ0064D0					
85	95			FQ0066D0					
90	100			FQ0070D0					
95	105			FQ0071D0					
97	107			FQ0251D0					
100	110			FQ0072D0					
105	115			FQ0075D0					
106	116			FQ0078D0					
110	120			FQ0079D0					

DSI TYPE DUST SEALS FOR RECIPROCAL MOVEMENT (INSTALLED IN INTERNAL GROOVE)

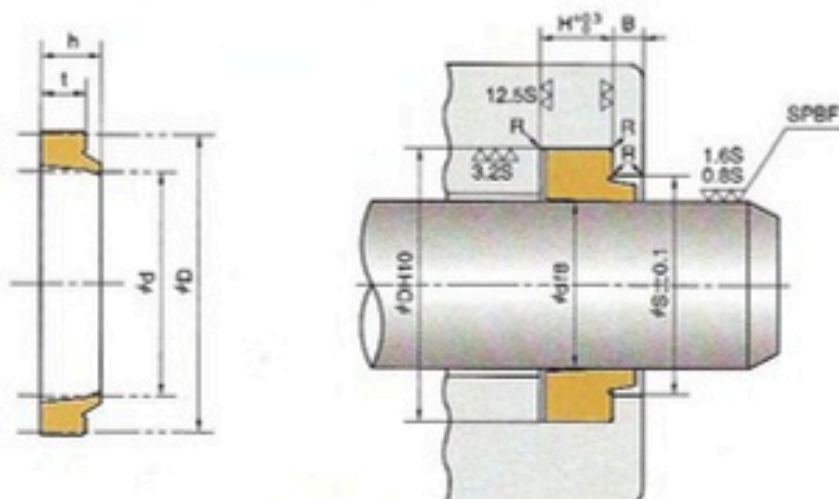

R = 0.3 or below

The surface of the rod should be finished by buffing (SPBF) or burnishing (RLB) to 0.8 to 1.6 μ mRmax (0.2 to 0.4 μ mRz). Specially under severe lubricating condition, burnishing is required.

Nominal Size of Dust Seal				Housing dimensions					NOK Part Number
d	D	t	h	ϕd	ϕD	ϕS	H	B	
112	122	6	8	112	122	117	7		FQ0082D0
118	128			118	128	123			FQ0085D0
120	130			120	130	125			FQ0087D0
125	138			125	138	132			FQ0091D0
130	143	7	9.5	130	143	137	8	4	FQ0093D0
132	145			132	145	139			FQ0095D0
140	153			140	153	147			FQ0097D0
145	158			145	158	152			FQ0099D0
150	163			150	163	157			FQ0101D0
155	168			155	168	162			FQ0103D0
160	173			160	173	167			FQ0105D0
170	183			170	183	177			FQ0106D0
175	188			175	188	182			FQ0108D0
180	193			180	193	187			FQ0111D0
185	198			185	198	192			FQ0114D0
190	203			190	203	197			FQ0115D0
199	212			199	212	206			FQ0116D0
200	213			200	213	207			FQ0117D0
204	217			204	217	211			FQ0119D0
210	223			210	223	217			FQ0120D0
215	228	215	228	222	FQ0408D1				
220	233	220	233	227	FQ0123D0				
224	237	224	237	231	FQ0124D0				
225	238	225	238	232	FQ0125D0				
230	243	230	243	237	FQ0127D0				
240	253	240	253	247	FQ0129D0				
250	263	250	263	257	FQ0130D0				
260	275	9	12	260	275	268	10	5	FQ0134D0
270	285			270	285	278			FQ0135D0
280	295			280	295	288			FQ0136D0
290	305			290	305	298			FQ0138D0
300	315			300	315	308			FQ0139D0

LBI TYPE

DUST SEALS FOR RECIPROCAL MOVEMENT
NOXLAN (AU)



- Please designate NOK Part number and type & size on your order.

(Example) • Type Dimensions LBI 18 26 4.5 6

Type Sign

Nominal Size of Dust Seal
described in order of inner diameter(d), outer diameter(D), thickness(t)
and height(h)

• Part Number FQ0013C0

- Please check the application range on pages D-2 and 3 before selecting the type.

Material	NOK U593
----------	----------

LBI TYPE DUST SEALS FOR RECIPROCAL MOVEMENT (INSTALLED IN INTERNAL GROOVE)

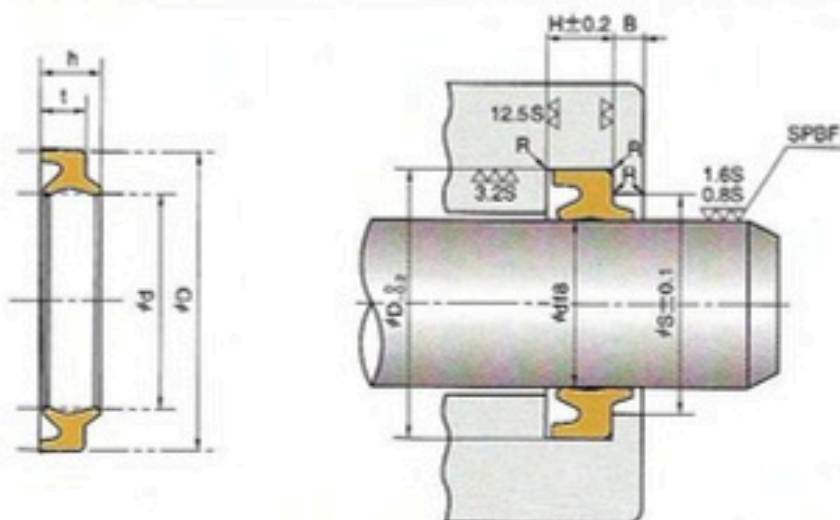

R ≤ 0.3 or below
R_z ≤ 0.5 or below

The surface of the rod should be finished by buffing (SPBF) or burnishing (RLB) to 0.8 to 1.6 μm R_{max} (0.2 to 0.4 μm R_a). Specially under severe lubricating condition, burnishing is required.

Nominal Size of Dust Seal				Housing dimensions					NOK Part Number			
d	D	t	h	φd	φD	φS	H	B				
18	26	4.5	6	18	26	22.3	5		FQ0013C0			
20	28			FQ0014C0								
22	30			FQ00651C0								
22.4	30.4			FQ0016C0								
25	33			FQ0018C0								
26	34			FQ00841C0								
28	36			FQ0023C0								
30	38			FQ0025C1								
31.5	39.5			FQ0027C0								
32	40			FQ0568C1								
34	42	5	6.5	34	42	38	6	2	FQ0285C0			
35	43			35	43	39			FQ0031C1			
35.5	43.5			35.5	43.5	39.5			FQ0034C0			
38	46			38	46	42			FQ0281C1			
40	48			40	48	44			FQ0035C1			
45	53			45	53	49			FQ0039C1			
48	56			48	56	52			FQ0272C0			
50	58			50	58	54			FQ0041C0			
55	63			55	63	59			FQ0045C1			
56	64			56	64	60			FQ0048C1			
58	66	58	66	62	FQ0286C0							
60	68	60	68	64	FQ0049C1							
63	71	63	71	67	FQ0054C0							
65	73	65	73	69	FQ0057C1							
70	80	6	8	70	80	75	7	3	FQ0059C0			
71	81			71	81	76			FQ0062C0			
75	85			75	85	80			FQ0063C0			
80	90			80	90	85			FQ0064C0			
85	95			85	95	90			FQ0066C0			
90	100			90	100	95			FQ0070C0			
95	105			95	105	100			FQ0071C0			
100	110			100	110	105			FQ0072C0			
105	115			105	115	110			FQ0075C0			
112	122			112	122	117			FQ0082C0			
125	138	7	9.5	125	138	132	8		FQ0091C0			
140	153			140	153	147			FQ0097C0			
150	163			150	163	157			FQ0101C0			
180	193			180	193	187			FQ0111C0			
185	198			185	198	192			FQ0114C0			
200	213			200	213	207			FQ0117C0			
210	223			210	223	217			FQ0120C0			
250	265			9	11.5	250			265	258	10	FQ0131C0

LBH TYPE

DUST SEALS

NITRILE RUBBER (NBR)

FLUORORUBBER (FKM)



- Please designate NOK Part number and type & size on your order.

(Example) · Type Dimensions LBH 12.5 20.5 4.5 6

Type Sign

Nominal Size of Dust Seal described in order of inner diameter(d), outer diameter(D), thickness(t) and height(h)

· Part Number CL0447C1

- Please check the application range on pages D-2 and 3 before selecting the type.

Material	Standard : NOK A505 Heat resistant type : NOK F357
-----------------	---

LBH_{TYPE} DUST SEALS (INSTALLED IN INTERNAL GROOVE)

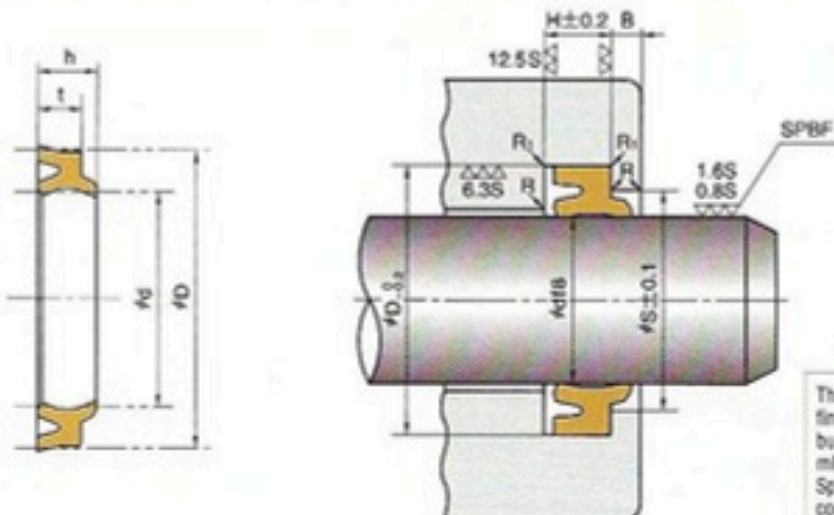

Nominal Size of Dust Seal				Housing dimensions				Standard (A505)		Heat resistant (F357)		
d	D	t	h	φd	φD	φS	H	B	NOK Part Number	Nominal number	NOK Part Number	Nominal number
12.5	20.5	4.5	6	12.5	20.5	16.8	5		CL0447C1	LBH-12.5		
14	22			14	22	18.3			CL0432C0	LBH-14		
16	24			16	24	20.3			CL0293C0	LBH-16	CL0293C3	LBH-16F
18	26			18	26	22.3			CL0011C0	LBH-18	CL0011C6	LBH-18F
20	28			20	28	24.3			CL0017C0	LBH-20	CL0017C4	LBH-20F
22	30			22	30	26.3			CL0240C0	LBH-22		
22.4	30.4			22.4	30.4	26.7			CL0026C3	LBH-22.4	CL0026C6	LBH-22.4F
25	33			25	33	29.3			CL0031C0	LBH-25	CL0031C2	LBH-25F
28	36			28	36	32.3			CL0042C0	LBH-28	CL0042C4	LBH-28F
30	38			30	38	34			CL0050C0	LBH-30	CL0050C3	LBH-30F
31.5	39.5	5	6.5	31.5	39.5	35.5	6	2	CL0054C0	LBH-31.5	CL0054C3	LBH-31.5F
32	40			32	40	36			CL0363C0	LBH-32	CL0363C3	LBH-32F
35	43			35	43	39			CL0066C1	LBH-35	CL0066C4	LBH-35F
35.5	43.5			35.5	43.5	39.5			CL0072C0	LBH-35.5	CL0072C4	LBH-35.5F
36	44			36	44	40			CL0335C1	LBH-36		
40	48			40	48	44			CL0077C2	LBH-40	CL0077C4	LBH-40F
45	53			45	53	49			CL0085C0	LBH-45	CL0085C4	LBH-45F
50	58			50	58	54			CL0087C3	LBH-50	CL0087C5	LBH-50F
53	61			53	61	57			CL0100C0	LBH-53	CL0100C2	LBH-53F
55	63			55	63	59			CL0104C0	LBH-55	CL0104C2	LBH-55F
56	64	56	64	60	CL0105C1	LBH-56	CL0105C4	LBH-56F				
60	68	60	68	64	CL0107C0	LBH-60	CL0107C2	LBH-60F				
63	71	63	71	67	CL0109C1	LBH-63	CL0109C3	LBH-63F				
65	73	65	73	69	CL0115C0	LBH-65	CL0115C2	LBH-65F				
67	75	67	75	71	CL0118C1	LBH-67						
70	80	6	8	70	80	75	7	3	CL0121C0	LBH-70	CL0121C3	LBH-70F
71	81			71	81	76			CL0125C0	LBH-71	CL0125C2	LBH-71F
75	85			75	85	80			CL0127C0	LBH-75	CL0127C2	LBH-75F
80	90			80	90	85			CL0138C1	LBH-80	CL0138C3	LBH-80F
85	95			85	95	90			CL0142C0	LBH-85	CL0142C3	LBH-85F
90	100			90	100	95			CL0149C0	LBH-90	CL0149C4	LBH-90F
95	105			95	105	100			CL0152C0	LBH-95	CL0152C3	LBH-295F

Remark) The Part number and the one stamped on the product might be different in case of the heat resistant type.

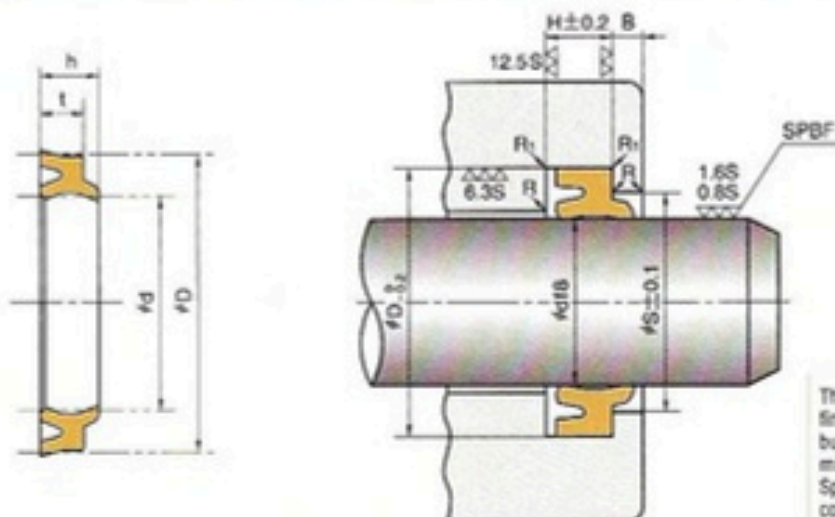

R = 0.3 or below
R₁ = 0.5 or below

The surface of the rod should be finished by buffing (SPBF) or burnishing (RLB) to 0.8 to 1.6 μm R_{max} (0.2 to 0.4 μm R_a). Specially under severe lubricating condition, burnishing is required.

Nominal Size of Dust Seal				Housing dimensions					Standard (A505)		Heat resistant (F357)	
d	D	t	h	φd	φD	φS	H	B	NOK Part Number	Nominal number	NOK Part Number	Nominal number
100	110	6	8	100	110	105	7	3	CL0154C2	LBH-80	CL0154C4	LBH-80F
105	115			105	115	110			CL0476C0	LBH-85A		
108	116			106	116	111			CL0162C0	LBH-85		
110	120			110	120	115			CL0448C0	LBH-90	CL0448C2	LBH-90F
112	122			112	122	117			CL0166C2	LBH-95	CL0166C3	LBH-95F
115	125			115	125	120			CL0478C0	LBH-98		
118	128	7	9.5	118	128	123	8	3	CL0466C0	LBH-100		
125	138			125	138	132			CL0171C0	LBH-106	CL0171C3	LBH-100F
132	145			132	145	139			CL0174C0	LBH-112		
140	153			140	153	147			CL0179C1	LBH-112A	CL0179C4	LBH-112F
145	158			145	158	152			CL0182C0	LBH-118		
150	163			150	163	157			CL0185C0	LBH-125		
160	173	11	14	160	173	167	12	5	CL0188C1	LBH-130	CL0188C3	LBH-125F
165	178			165	178	172			CL0487C0	LBH-132		
170	185			170	185	178			CL0190C0	LBH-136		
175	188			175	188	182			CL0191C0	LBH-140		
180	193			180	193	187			CL0193C0	LBH-145		
180	194			180	194	187			CL0196C1	LBH-150	CL0196C4	LBH-150F
200	213	7	9.5	200	213	207	8	3	CL0489C0	LBH-155		
205	218			205	218	212			CL0199C1	LBH-160	CL0199C3	LBH-145F
210	223			210	223	217			CL0446C0	LBH-165		
224	237			224	237	231			CL0324C1	LBH-175		
240	256			240	256	248			CL0204C1	LBH-180	CL0204C2	LBH-160F
250	266			250	266	258			CL0300C0	LBH-190		
250	266	10	13	250	266	258	11	4	CL0207C0	LBH-200		
280	296			280	296	288			CL0267C0	LBH-204		
355	375			355	375	365			CL0212C0	LBH-224	CL0212C2	LBH-200F
500	520	11.5	15.5	500	520	510	12.5	5	CL0301C0	LBH-230		
				500	520	510			CL0460C0	LBH-240		

Remark) The Part number and the one stamped on the product might be different in case of the heat resistant type.

HBY TYPE

BUFFER RING

NOXLAN (AU) + POLYAMIDE RESIN (PA)



- Please designate NOK Part number and type & size on your order.

(Example) • Type Dimensions HBY 35.5 51 6

Type Sign

Nominal Size of Buffer Ring
described in order of inner diameter(d), outer diameter(D), and height(h)

• Part Number FQ0795F0

- Please check the application range on pages D-2 and 3 before selecting the type.

Material	NOK U801 + NOK 80NP
----------	---------------------

HBTYPE BUFFER RING

HOW TO DETERMINE B DIMENSION

Please determine B dimension according to the table below. If you require larger B dimension because of the cylinder configuration, please consult NOK.

Working Service Pressure	35MPa	42MPa	50MPa
B Dimension	$d + 0.8$	$d + 0.4$	$d + 0.25$

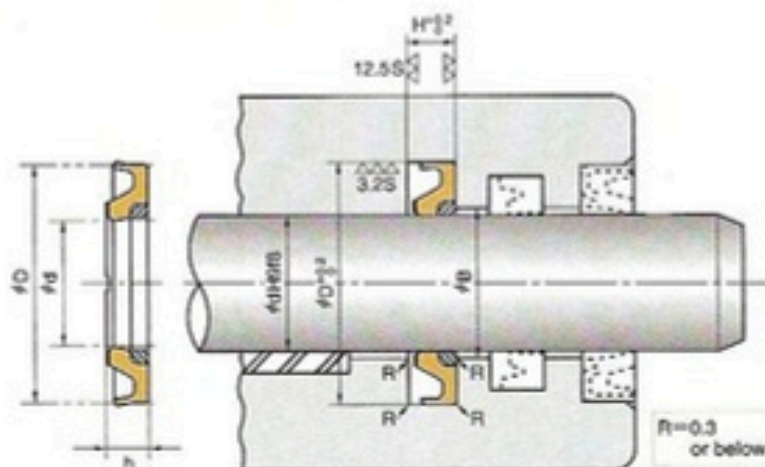

Nominal Size of Buffer Ring			Housing dimensions			NOK Part Number
d	D	h	#d	#D	H	
35.5	51	6	35.5	51	6.3	FQ0795F0
40	55.5		FQ0253F1			
45	60.5		FQ0254F1			
50	65.5		FQ0255F1			
55	70.5		FQ0256F1			
60	75.5		FQ0257F1			
65	80.5		FQ0258F1			
70	85.5		FQ0244F1			
75	90.5		FQ0245F1			
80	95.5		FQ0246F1			
85	100.5		FQ0259F1			
90	105.5		FQ0260F1			
95	110.5		FQ0575F0			
100	115.5		FQ0261F1			
105	120.5		FQ0629F0			
110	125.5		FQ0262F1			
115	130.5		FQ0868F0			
120	135.5		FQ0263F1			
125	140.5		FQ0842F0			
130	145.5		FQ0264F1			
132	147.5		FQ0784F1			
135	150.5		FQ0904F0			
140	155.5		FQ0265F1			
150	165.5	FQ0871F1				
160	175.5	FQ0433F1				
170	185.5	FQ0603F0				
180	195.5	FQ0451F0				
190	205.5	FQ0646F0				
200	221	7.7	200	221	8	FQ0830F0
210	231		210	231		FQ0824F0

HBTS_{TYPE}

BUFFER RING

RAREFLON (PTFE) + NITRILE RUBBER (NBR)



- Please designate NOK Part number and type & size on your order.

(Example) · Type Dimensions HBTS 40 55.5 5.9

Type Sign

Nominal Size of Buffer Ring
described in order of inner diameter(d), outer diameter(D), and height(h)

· Part Number GS0707V2

- Please check the application range on page D-4 before selecting the type.

Material	NOK 19YF + NOK A626
-----------------	---------------------

HBTS TYPE BUFFER RING

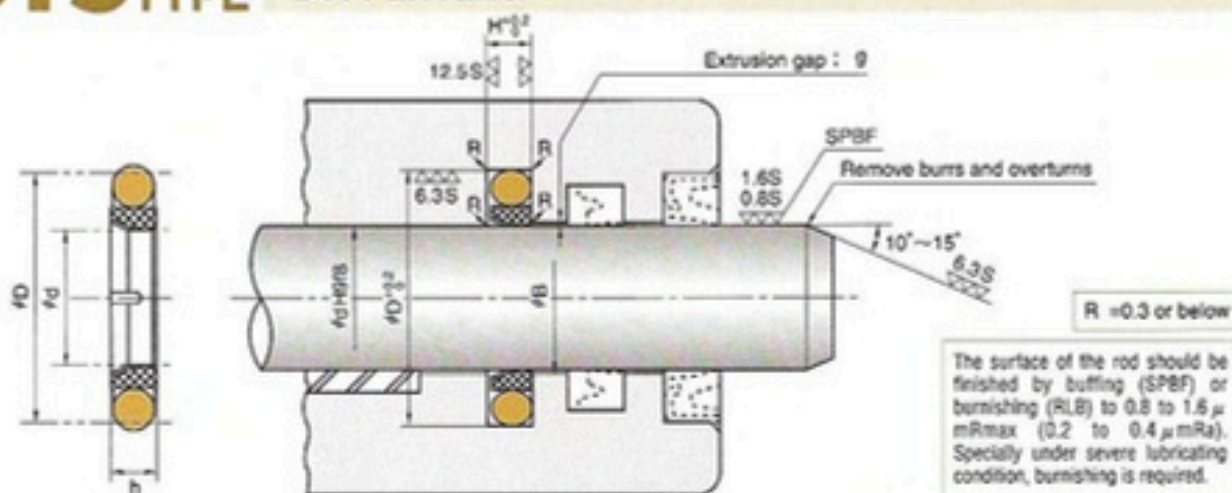

HOW TO DETERMINE B DIMENSION

To determine ϕB dimension, please refer to the graph in the right for the maximum extrusion gap (also refer page 26) considering the eccentricity of operating condition.

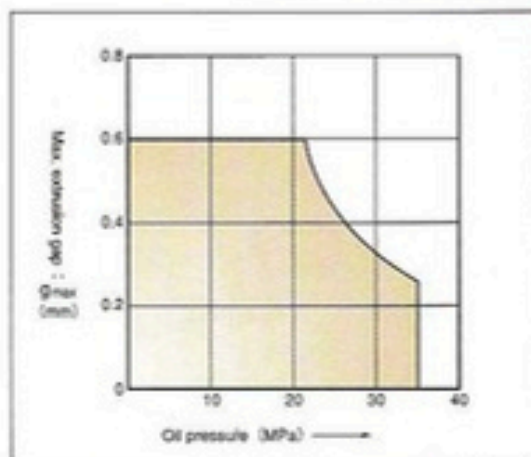

Extrusion Limit

Nominal Number	Nominal Size of Buffer Ring			Housing dimensions			NOK Part Number
	d	D	h	ϕd	ϕD	H	
HBTS 40	40	55.5	5.9	40	55.5	6.3	GS0707V2
45	45	60.5		45	60.5		GS0708V2
50	50	65.5		50	65.5		GS0709V2
55	55	70.5		55	70.5		GS0710V2
60	60	75.5		60	75.5		GS0711V2
65	65	80.5		65	80.5		GS0712V2
70	70	85.5		70	85.5		GS0713V2
75	75	90.5		75	90.5		GS0714V2
80	80	95.5		80	95.5		GS0715V2
85	85	100.5		85	100.5		GS0716V2
90	90	105.5		90	105.5		GS0717V2
100	100	115.5		100	115.5		GS0718V2
110	110	125.5		110	125.5		GS0719V2
120	120	135.5		120	135.5		GS0720V2
130	130	145.5	130	145.5	GS0721V2		
140	140	155.5	140	155.5	GS0722V2		

RYT_{TYPE}

WEAR RING
RAREFLON (PTFE)



- Please designate NOK Part number and type & size on your order.

(Example) • Type Dimensions

RYT 2 8

Type Sign

Nominal Size of Wear Ring
described in order of thickness(t) and height(h)

• Part Number GZ1291V0

- Please check the application range on page D-4 before selecting the type.

Material	NOK 05ZF
----------	----------

RYT TYPE WEAR RING

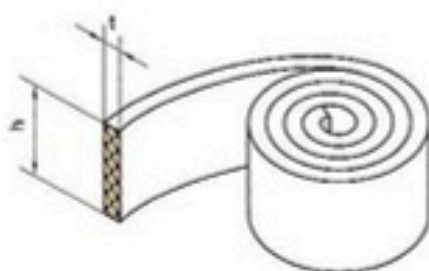

One roll length is 10 m.

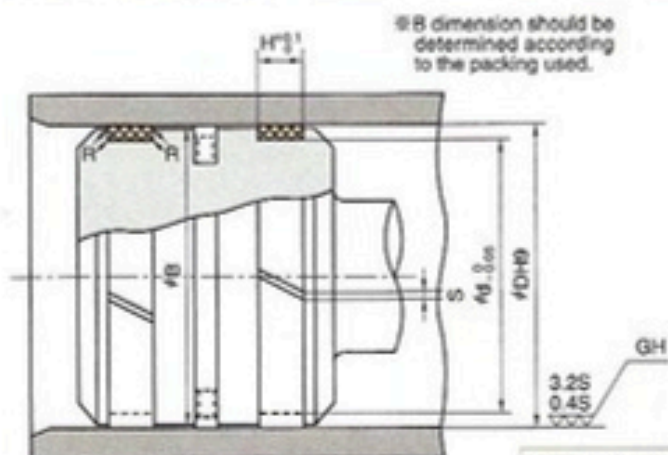

The inner surface of the cylinder tube should be finished by honing (GH) or burnishing (RLB) to 0.4 to 3.2 μm Rmax (0.1 to 0.8 μm Ra). Specially under severe lubricating condition, burnishing is required.

(Remark) Determine the length of wear ring = L according to the formula below.

$$L = \pi \cdot (D - t) - S$$

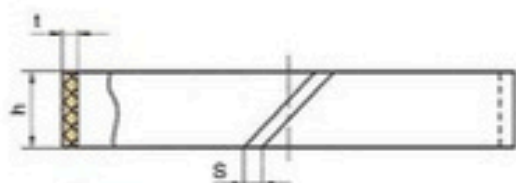

Nominal Number	Nominal Size of Wear Ring			Housing dimensions			NOK Part Number
	t	h	S	ϕD	ϕd	H	
RYT 8	2	8	1~1.5	18~63	D-4	8	GZ1291V0
10		10	1~2	33~80		10	GZ1292V0
15		15	1.5~3	41~130		15	GZ1293V0
20		20	2~4	65~160		20	GZ1294V0
25		25	2~6	85~225		25	GZ1295V0
30	2.5	30	3~6.5	112~250	D-5	30	GZ1296V0
35		35	3.5~8	132~300		35	GZ1297V0
40		40	4~9	150~350		40	GZ1298V0
45		45	4~10	165~400		45	GZ1299V0
50		50	5~11	205~450		50	GZ1300V0
55	3	55	6~13	230~500	D-6	55	GZ1301V0
60		60	7~15	260~600		60	GZ1302V0
60		60	7~15	260~600		60	GZ1302V0
70		70	8~28	290~1000		70	GZ1303V0

RYT type wear ring of other dimensions than the above can be available on demand.

WR_{TYPE}

WEAR RING
FABRIC REINFORCED PHENOLIC RESIN



- Please designate NOK Part number and type & size on your order.

(Example) • Type Dimensions

WR 14 18 8

Type Sign

Nominal Size of Wear Ring
described in order of inner diameter(d), outer diameter(D), and height(h)

• Part Number GW0241P0

- Please check the application range on page D-4 before selecting the type.

Material	NOK 12RS
-----------------	----------

WR_{TYPE} WEAR RING (FOR U TYPE PACKINGS)

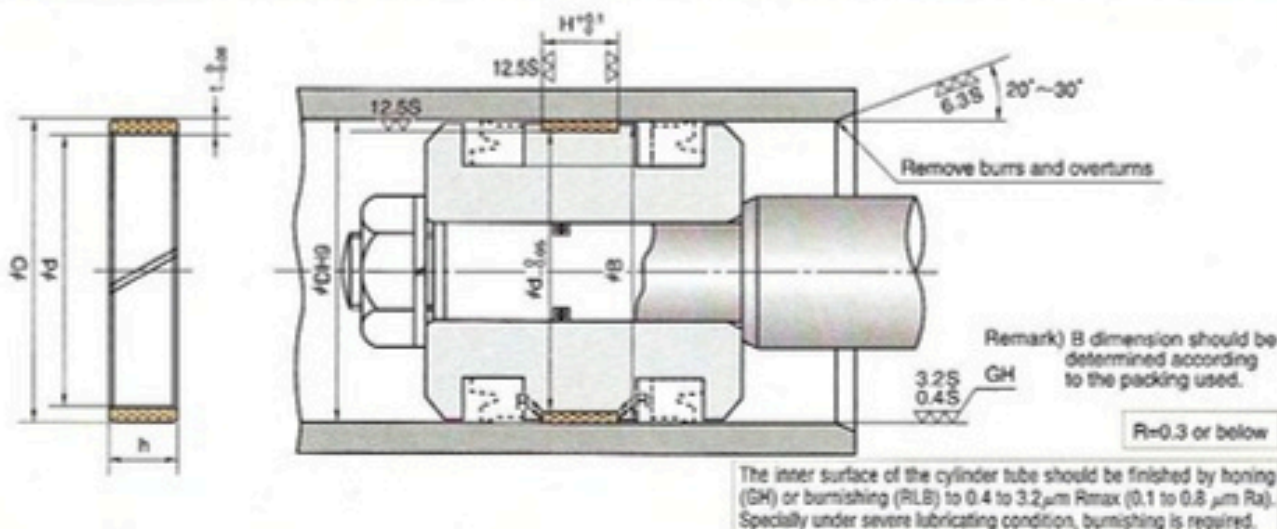

Nominal Number	Nominal Size of Wear Ring				Housing dimensions			NOK Part Number
	d	D	h	t	ϕd	ϕD	H	
WR 18	14	18	8	2	14	18	8	GW0241P0
19.2	15.2	19.2			GW0242P0			
20	16	20			GW0243P0			
22	18	22			GW0244P0			
24	20	24			GW0245P0			
25	21	25			GW0246P0			
26	22	26			GW0247P0			
28	24	28			GW0248P0			
30	26	30			GW0249P0			
31	27	31			GW0250P0			
31.5	27.5	31.5			GW0251P0			
33	29	33			10	2		29
35	31	35	GW0253P0					
35.4	31.4	35.4	GW0254P0					
35.5	31.5	35.5	GW0255P0					
38	34	38	GW0256P0					
40	36	40	GW0257P0					
41	37	41	15	2.5	37	41	15	GW0258P0
43	38	43			GW0259P0			
44.5	39.5	44.5			GW0260P0			
45	40	45			GW0261P0			
50	45	50			GW0006P1			
51.5	46.5	51.5			GW0263P0			
55	50	55			GW0264P0			
58	51	56			GW0010P1			
60	55	60			GW0012P1			
61	56	61			GW0267P0			
63	58	63			GW0268P0			
65	60	65			20	2.5		60
68	61	66	GW0270P0					
69	64	69	GW0271P0					
70	65	70	GW0019P1					
71	66	71	GW0192P1					
75	70	75	GW0021P1					
76	71	76	GW0746P0					
80	75	80	GW0027P1					
85	79	85	25	3	79	85	25	GW0030P1
90	84	90			GW0036P1			
95	89	95			GW0167P1			
100	94	100			GW0041P3			

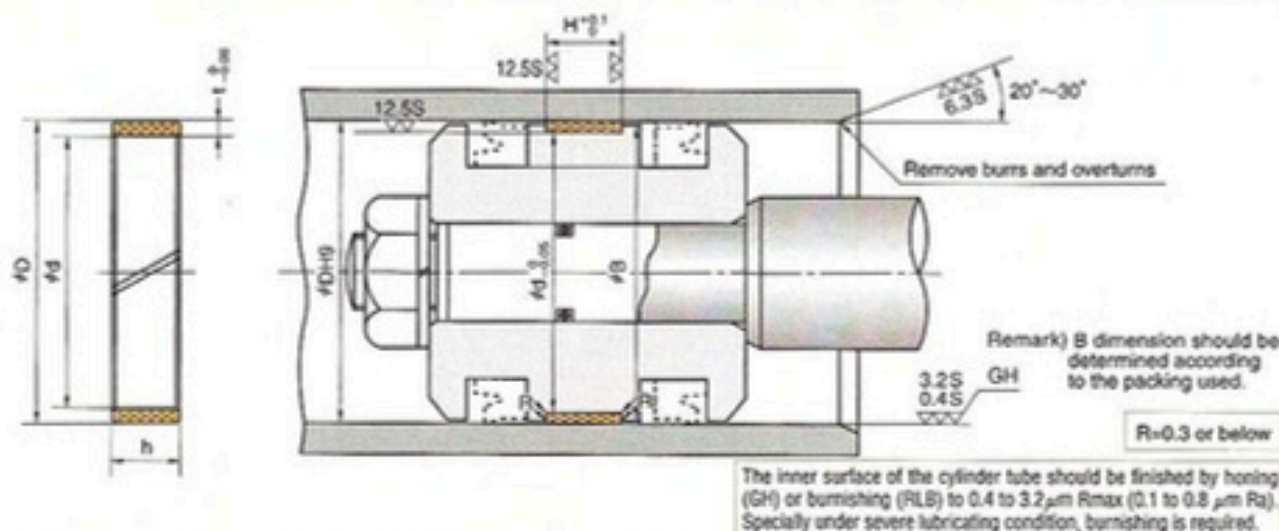

Nominal Number	Nominal Size of Wear Ring				Housing dimensions			NOK Part Number
	d	D	h	t	#d	#D	H	
WR 105	99	105	25	3	99	105	25	GW0278P0
110	104	110			104	110		GW0051P1
112	106	112	30		106	112	GW0280P0	
115	109	115			109	115	GW0055P2	
120	114	120			114	120	GW0059P1	
125	119	125			119	125	GW0283P0	
130	123	130	35	3.5	123	130	GW0065P1	
132	125	132			125	132	GW0285P0	
140	133	140			133	140	GW0075P1	
150	143	150			143	150	GW0086P1	
157	150	157	40		150	157	GW0287P0	
160	153	160			153	160	GW0093P2	
165	157	165	45	4	157	165	GW0289P0	
170	162	170			162	170	GW0290P0	
180	172	180			172	180	GW0104P1	
185	177	185			177	185	GW0292P0	
190	182	190	50		182	190	GW0293P0	
200	192	200			192	200	GW0109P1	
205	197	205			197	205	GW0181P0	
210	202	210			202	210	GW0296P0	
220	212	220	55		212	220	GW0297P0	
224	216	224			216	224	GW0298P0	
225	217	225			217	225	GW0115P1	
230	222	230			222	230	GW0300P0	
240	232	240	60	232	240	GW0301P0		
250	242	250		242	250	GW0122P1		
260	252	260		252	260	GW0303P0		
270	262	270		262	270	GW0304P0		
275	267	275	70	267	275	GW0305P0		
290	282	290		282	290	GW0307P0		
297	289	297		289	297	GW0308P0		
300	292	300		292	300	GW0309P0		
312	304	312	70	304	312	GW0310P0		
332	324	332		324	332	GW0311P0		

WR_{TYPE} WEAR RING (FOR PACKINGS OF SPG AND SPGW TYPE)

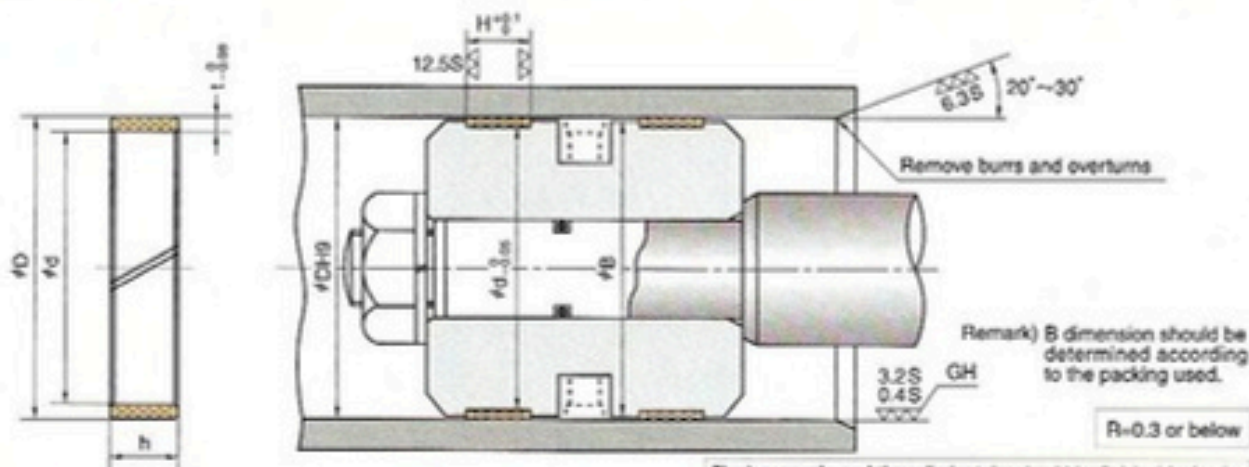

The inner surface of the cylinder tube should be finished by honing (GH) or burrishing (RLB) to 0.4 to 3.2 μ m Rmax (0.1 to 0.8 μ m Ra). Specially under severe lubricating condition, burrishing is required.

Nominal Number	Nominal Size of Wear Ring				Housing dimensions			NOK Part Number	
	d	D	h	t	#d	#D	H		
WR 30W	26	30	8	2	26	30	8	GW0249P0	
31.5W	27.5	31.5			27.5	31.5		GW0251P0	
32W	28	32			28	32		GW0314P0	
35W	31	35			31	35		GW0315P0	
35.5W	31.5	35.5			31.5	35.5		GW0316P0	
40W	36	40		2.5	2	36		40	GW0317P0
45W	40	45				40		45	GW0318P0
50W	45	50				45		50	GW0279P0
55W	50	55				50		55	GW0319P0
56W	51	56				51		56	GW0320P0
60W	55	60	55		60	GW0321P0			
63W	58	63	10		2.5	58	63	GW0322P0	
65W	60	65				60	65	GW0323P0	
69W	64	69				64	69	GW0324P0	
70W	65	70				65	70	GW0018P1	
71W	66	71		66		71	GW0326P0		
75W	70	75		70	75	GW0327P0			
80W	75	80		15	3	75	80	GW0025P1	
85W	79	85				79	85	GW0329P0	
90W	84	90				84	90	GW0330P0	
95W	89	95				89	95	GW0331P0	
100W	94	100	94			100	GW0332P0		
108W	102	108	20		3	102	108	GW0333P0	
110W	104	110				104	110	GW0334P0	
112W	106	112				106	112	GW0335P0	
120W	114	120				114	120	GW0336P0	
125W	119	125				119	125	GW0337P0	
130W	123	130		25	3.5	123	130	GW0338P0	
140W	133	140				133	140	GW0339P0	
150W	143	150				143	150	GW0340P0	
160W	153	160				153	160	GW0341P0	
170W	162	170				162	170	GW0342P0	
180W	172	180	30		4	172	180	GW0343P0	
190W	182	190				182	190	GW0344P0	
200W	192	200				192	200	GW0345P0	
204W	196	204				196	204	GW0346P0	
210W	202	210				202	210	GW0347P0	
224W	216	224		30	4	216	224	GW0348P0	
225W	217	225				217	225	GW0349P0	
230W	222	230				222	230	GW0350P0	
240W	232	240				232	240	GW0351P0	
250W	242	250				242	250	GW0352P0	

KZT TYPE CONTAMI SEALS

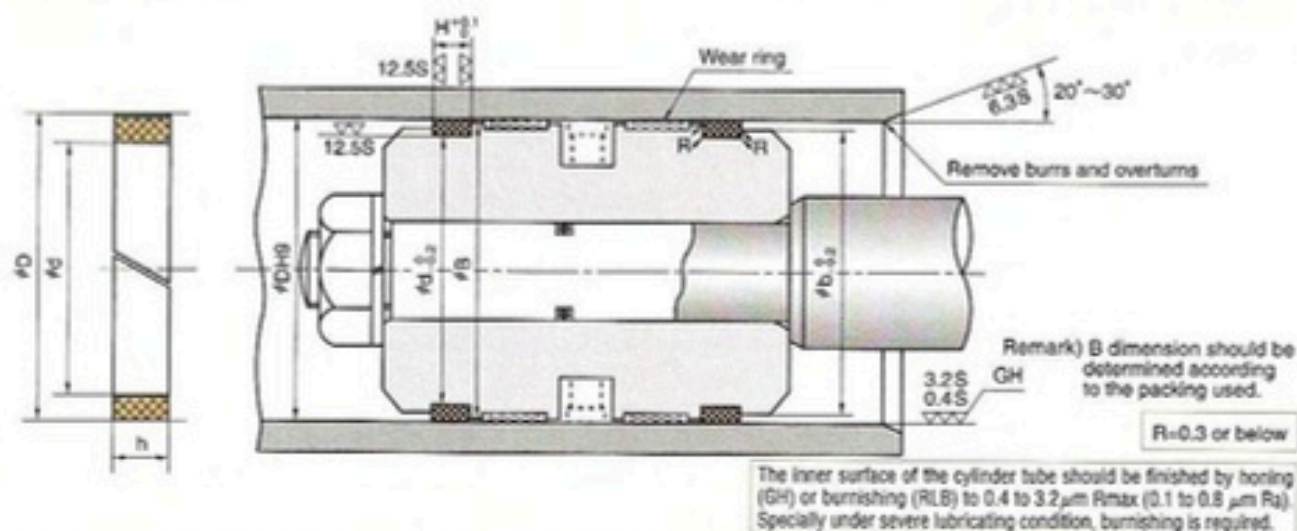

Nominal Number	Nominal Size of Contami Seal			Housing dimensions				NOK Part Number		
	d	D	h	#d	#D	#b	H			
KZT 20	14	20	5	14	20	18	5.2	GZ3000V0		
25	19	25		19	25	23		GZ3001V0		
30	24	30		24	30	28		GZ3002V0		
31.5	25.5	31.5		25.5	31.5	29.5		GZ3003V0		
32	26	32		26	32	30		GZ3004V0		
35	29	35		29	35	33		GZ3005V0		
35.5	29.5	35.5		29.5	35.5	33.5		GZ3006V0		
40	34	40		34	40	38		GZ3007V0		
45	39	45		39	45	43		GZ3008V0		
50	44	50		44	50	48		GZ3009V0		
53	47	53		47	53	51		GZ3010V0		
55	49	55		49	55	53		GZ3011V0		
56	50	56		50	56	54		GZ3012V0		
60	54	60		54	60	58		GZ3013V0		
63	55	63		6	55	63		61	6.2	GZ3014V0
65	57	65			57	65		63		GZ3015V0
70	62	70	62		70	68	GZ3016V0			
71	63	71	63		71	69	GZ3017V0			
75	67	75	67		75	73	GZ3018V0			
80	72	80	72		80	78	GZ3019V0			
85	77	85	77		85	83	GZ3020V0			
90	82	90	82		90	88	GZ3021V0			
95	87	95	87		95	93	GZ3022V0			
100	92	100	92		100	98	GZ3023V0			
105	97	105	97		105	103	GZ3024V0			

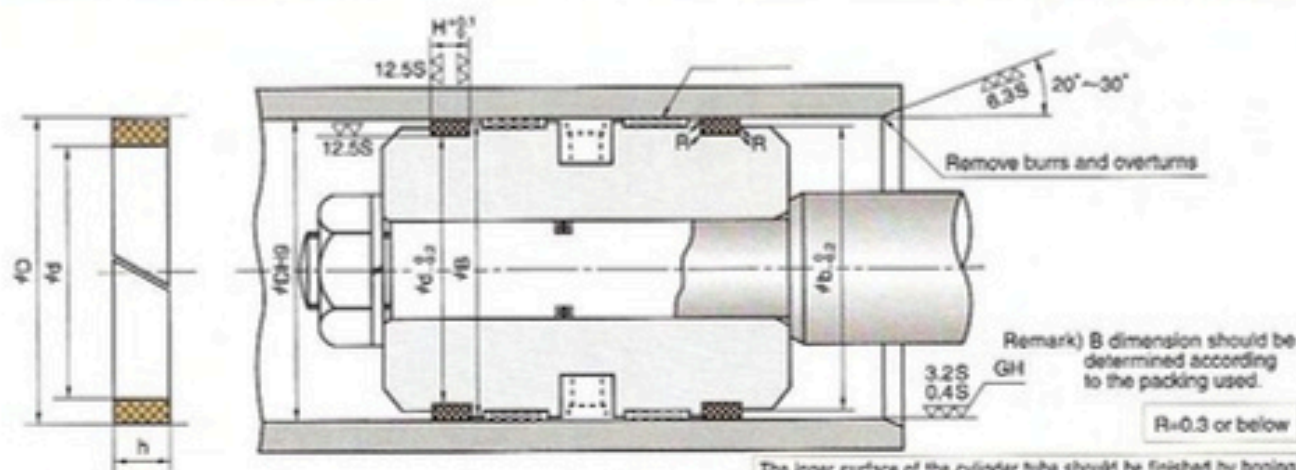

The inner surface of the cylinder tube should be finished by honing (GH) or burnishing (RLB) to 0.4 to 3.2 μm Ra (0.1 to 0.8 μm Rz). Specially under severe lubricating condition, burnishing is required.

Nominal Number	Nominal Size of Contami Seal			Housing dimensions				NOK Part Number
	d	D	h	φd	φD	φb	H	
KZT 110	102	110	6	102	110	108	6.2	GZ3025V0
112	104	112		104	112	110		GZ3026V0
115	107	115		107	115	113		GZ3027V0
120	112	120		112	120	118		GZ3028V0
125	117	125		117	125	123		GZ3029V0
130	122	130		122	130	128		GZ3030V0
135	127	135		127	135	133		GZ3031V0
140	132	140		132	140	138		GZ3032V0
150	142	150		142	150	148		GZ3033V0
160	152	160		152	160	158		GZ3034V0
170	162	170		162	170	168		GZ3035V0
180	172	180		172	180	178		GZ3036V0
190	182	190		182	190	188		GZ3037V0
200	192	200		192	200	198		GZ3038V0
210	202	210	202	210	208	GZ3039V0		
220	212	220	212	220	218	GZ3040V0		
224	216	224	216	224	222	GZ3041V0		
230	222	230	222	230	228	GZ3042V0		
240	232	240	232	240	238	GZ3043V0		
250	242	250	8	242	250	248	8.2	GZ3044V0
260	252	260		252	260	258		GZ3045V0
270	262	270		262	270	268		GZ3046V0
280	272	280		272	280	278		GZ3047V0
290	282	290		282	290	288		GZ3048V0
300	292	300		292	300	298		GZ3049V0
310	302	310		302	310	308		GZ3050V0
320	312	320		312	320	318		GZ3051V0
340	332	340		332	340	338		GZ3052V0
350	342	350		342	350	348		GZ3053V0
360	352	360		352	360	358		GZ3054V0

BRT2_{TYPE} BRT3_{TYPE}

BACKUP RING
RAREFLON (PTFE)

BRN2_{TYPE} BRN3_{TYPE}

POLYAMIDE RESIN (PA)



F

- Please designate NOK Part number and type & size on your order.

(Example) • Type Dimensions BRT2 8 18 2

Type Sign

Nominal Size of Backup Ring
described in order of inner diameter(d), outer diameter(D), and thickness(t)

• Part Number GN4773V0

- Please check the application range on page D-4 before selecting the type.

Material	BRT2 AND 3 TYPE :	NOK 19YF
		NOK 31BF
	BRN2 AND 3 TYPE :	NOK 80NP

BRT2_{TYPE}, **BRT3**_{TYPE} (MATERIAL: NOK RAREFLON)
BRN2_{TYPE}, **BRN3**_{TYPE} (MATERIAL: NOK POLYAMIDE RESIN)

BACKUP RING

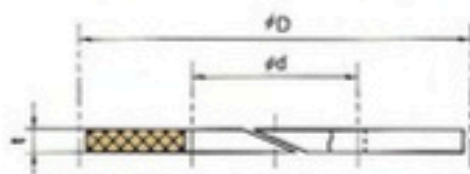

(Biascut)

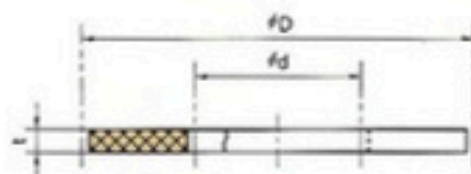

(Endless)

Type of cut			Biascut			Endless		
NOK type			BRT2	BRT2	BRN2	BRT3	BRT3	BRN3
NOK material sign			19YF	31BF	80NP	19YF	31BF	80NP
Nominal Size of Backup Ring			NOK	NOK	NOK	NOK	NOK	NOK
d	D	t	Part Number	Part Number	Part Number	Part Number	Part Number	Part Number
8	18	2	GN4773V0	GN4773F0	GN9101O0	GN0725V0	GN0725F0	GN9101O1
10	20		GN4774V0	GN4774F0	GN9102O0	GN0733V0	GN0733F0	GN9102O1
14	24		GN4775V0	GN4775F0	GN9103O0	GN0745V0	GN0745F0	GN9103O1
15	28		GN4776V0	GN4776F0	GN9104O0	GN6445V0	GN6445F0	GN9104O1
16	26		GN4777V0	GN4777F0	GN9105O0	GN0751V0	GN0751F0	GN9105O1
18			GN4778V0	GN4778F0	GN9106O0	GN6377V0	GN6377F0	GN9106O1
20	31		GN4779V0	GN4779F0	GN9107O0	GN6446V0	GN6446F0	GN9107O1
	28		GN4780V0	GN4780F0	GN9108O0	GN6447V0	GN6447F0	GN9108O1
	30		GN4781V0	GN4781F0	GN9109O0	GN0762V0	GN0762F0	GN9109O1
22	33		GN4782V0	GN4782F0	GN9110O0	GN6448V0	GN6448F0	GN9110O1
	35		GN4783V0	GN4783F0	GN9111O0	GN6449V0	GN6449F0	GN9111O1
	22.4		30	GN4784V0	GN4784F0	GN9112O0	GN6450V0	GN6450F0
23.5	33		GN4785V0	GN4785F0	GN9113O0	GN6451V0	GN6451F0	GN9113O1
	31.5		GN4786V0	GN4786F0	GN9114O0	GN6452V0	GN6452F0	GN9114O1
25	35		GN4787V0	GN4787F0	GN9115O0	GN0781V0	GN0781F0	GN9115O1
	38		GN4788V0	GN4788F0	GN9116O0	GN6453V0	GN6453F0	GN9116O1
25.5	35.5		GN4789V0	GN4789F0	GN9117O0	GN6454V0	GN6454F0	GN9117O1
27	40		GN4790V0	GN4790F0	GN9118O0	GN6455V0	GN6455F0	GN9118O1
28	35.5	GN4791V0	GN4791F0	GN9119O0	GN6456V0	GN6456F0	GN9119O1	
	40	GN4792V0	GN4792F0	GN9120O0	GN6457V0	GN6457F0	GN9120O1	
	41	GN4793V0	GN4793F0	GN9121O0	GN6458V0	GN6458F0	GN9121O1	
30	40	GN4794V0	GN4794F0	GN9122O0	GN6361V0	GN6361F0	GN9122O1	
	43	GN4795V0	GN4795F0	GN9123O0	GN6459V0	GN6459F0	GN9123O1	
31.5	41.5	GN4796V0	GN4796F0	GN9124O0	GN6460V0	GN6460F0	GN9124O1	
	44.5	GN4797V0	GN4797F0	GN9125O0	GN6461V0	GN6461F0	GN9125O1	
34	50	GN4798V0	GN4798F0	GN9126O0	GN6462V0	GN6462F0	GN9126O1	
35	45	GN4799V0	GN4799F0	GN9127O0	GN6463V0	GN6463F0	GN9127O1	
	50	GN4800V0	GN4800F0	GN9128O0	GN0816V0	GN0816F0	GN9128O1	
35.5	45	GN4801V0	GN4801F0	GN9129O0	GN6464V0	GN6464F0	GN9129O1	
	51.5	GN4802V0	GN4802F0	GN9130O0	GN6330V0	GN6330F0	GN9130O1	
40	50	GN4050V0	GN4050F0	GN9131O0	GN6465V0	GN6465F0	GN9131O1	
	56	GN4803V0	GN4803F0	GN9132O0	GN6466V0	GN6466F0	GN9132O1	
45	55	GN4804V0	GN4804F0	GN9133O0	GN6467V0	GN6467F0	GN9133O1	
	56	GN4805V0	GN4805F0	GN9134O0	GN6468V0	GN6468F0	GN9134O1	
47	61	GN4806V0	GN4806F0	GN9135O0	GN6469V0	GN6469F0	GN9135O1	
	63	GN4807V0	GN4807F0	GN9136O0	GN6470V0	GN6470F0	GN9136O1	
50	60	GN4808V0	GN4808F0	GN9137O0	GN6471V0	GN6471F0	GN9137O1	
	66	GN4335V0	GN4335F0	GN9138O0	GN6302V0	GN6302F0	GN9138O1	
53	66	GN4809V0	GN4809F0	GN9139O0	GN6329V0	GN6329F0	GN9139O1	
	63	GN4693V0	GN4693F0	GN9140O0	GN6413V0	GN6413F0	GN9140O1	

F

BRT2_{TYPE}, **BRT3**_{TYPE} (MATERIAL: NOK RAREFLON)

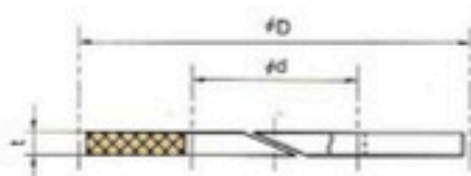
BACKUP RING
BRN2_{TYPE}, **BRN3**_{TYPE} (MATERIAL: NOK POLYAMIDE RESIN)

(Biascut)

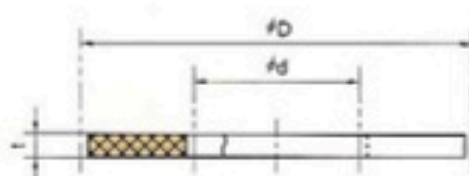

(Endless)

Type of cut			Biascut			Endless		
NOK type			BRT2	BRT2	BRN2	BRT3	BRT3	BRN3
NOK material sign			19YF	31BF	80NP	19YF	31BF	80NP
Nominal Size of Backup Ring			NOK	NOK	NOK	NOK	NOK	NOK
d	D	t	Part Number	Part Number	Part Number	Part Number	Part Number	Part Number
55	65	3	GN4810V0	GN4810F0	GN9141O0	GN6472V0	GN6472F0	GN9141O1
	71		GN4811V0	GN4811F0	GN9142O0	GN6473V0	GN6473F0	GN9142O1
56	66		GN4766V0	GN4766F0	GN9143O0	GN6474V0	GN6474F0	GN9143O1
60	70		GN4676V0	GN4676F0	GN9144O0	GN6444V0	GN6444F0	GN9144O1
	71		GN4812V0	GN4812F0	GN9145O0	GN6475V0	GN6475F0	GN9145O1
	76		GN4813V0	GN4813F0	GN9146O0	GN6476V0	GN6476F0	GN9146O1
63	73		GN4814V0	GN4814F0	GN9147O0	GN6477V0	GN6477F0	GN9147O1
64	80		GN4815V0	GN4815F0	GN9148O0	GN6478V0	GN6478F0	GN9148O1
65	75		GN4816V0	GN4816F0	GN9149O0	GN6479V0	GN6479F0	GN9149O1
67	77		GN4697V0	GN4697F0	GN9150O0	GN6480V0	GN6480F0	GN9150O1
70	80		GN4651V0	GN4651F0	GN9092O0	GN6362V0	GN6362F0	GN9092O1
	90		GN4817V0	GN4817F0	GN9151O0	GN0910V0	GN0910F0	GN9151O1
71	80		GN4818V0	GN4818F0	GN9152O0	GN6481V0	GN6481F0	GN9152O1
	81		GN4819V0	GN4819F0	GN9153O0	GN6482V0	GN6482F0	GN9153O1
75	95		GN4524V0	GN4524F0	GN9154O0	GN0920V0	GN0920F0	GN9154O1
80	90		GN4820V0	GN4820F0	GN9155O0	GN6483V0	GN6483F0	GN9155O1
	100		GN4095V1	GN4095F0	GN9156O0	GN0927V0	GN0927F0	GN9156O1
85	100		GN4687V0	GN4687F0	GN9091O0	GN6484V0	GN6484F0	GN9091O1
	105		GN4821V0	GN4821F0	GN9157O0	GN0932V0	GN0932F0	GN9157O1
90	105		GN4698V0	GN4698F0	GN9158O0	GN6485V0	GN6485F0	GN9158O1
	110	GN4109V0	GN4109F0	GN9159O0	GN0939V0	GN0939F0	GN9159O1	
95	115	GN4822V0	GN4822F0	GN9160O0	GN6486V0	GN6486F0	GN9160O1	
	112	GN4823V0	GN4823F0	GN9161O0	GN0945V0	GN0945F0	GN9161O1	
98	112	GN4824V0	GN4824F0	GN9162O0	GN6487V0	GN6487F0	GN9162O1	
100	115	GN4512V0	GN4512F0	GN9163O0	GN6488V0	GN6488F0	GN9163O1	
	120	GN4119V0	GN4119F0	GN9164O0	GN0952V0	GN0952F0	GN9164O1	
105	125	GN4825V0	GN4825F0	GN9165O0	GN0959V0	GN0959F0	GN9165O1	
106	120	GN4826V0	GN4826F0	GN9166O0	GN6489V0	GN6489F0	GN9166O1	
112	125	GN4827V0	GN4827F0	GN9167O0	GN6490V0	GN6490F0	GN9167O1	
	132	GN4828V0	GN4828F0	GN9168O0	GN0970V0	GN0970F0	GN9168O1	
120	140	GN4132V0	GN4132F0	GN9169O0	GN0982V0	GN0982F0	GN9169O1	
125	140	GN4481V0	GN4481F0	GN9170O0	GN6491V0	GN6491F0	GN9170O1	
	150	GN4401V0	GN4401F0	GN9171O0	GN6135V0	GN6135F0	GN9171O1	
135	160	GN4829V0	GN4829F0	GN9172O0	GN6492V0	GN6492F0	GN9172O1	
136	150	GN4830V0	GN4830F0	GN9173O0	GN6493V0	GN6493F0	GN9173O1	
140	165	GN4831V0	GN4831F0	GN9174O0	GN6494V0	GN6494F0	GN9174O1	
145	160	GN4551V0	GN4551F0	GN9175O0	GN6495V0	GN6495F0	GN9175O1	
	170	GN4832V0	GN4832F0	GN9176O0	GN6496V0	GN6496F0	GN9176O1	
150	165	GN4833V0	GN4833F0	GN9177O0	GN6497V0	GN6497F0	GN9177O1	
155	170	4	GN4834V0	GN4834F0	GN9178O0	GN6498V0	GN6498F0	GN9178O1

BRT2_{TYPE}, BRT3_{TYPE} BRN2_{TYPE}, BRN3_{TYPE}

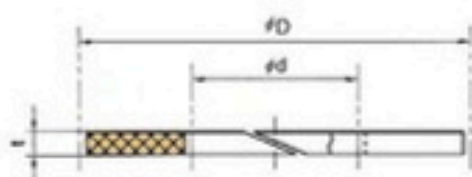

(Biascut)

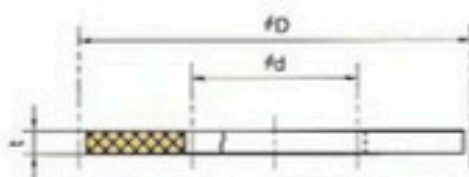

(Endless)

Type of cut			Biascut			Endless		
NOK type			BRT2	BRT2	BRN2	BRT3	BRT3	BRN3
NOK material sign			19YF	31BF	80NP	19YF	31BF	80NP
Nominal Size of Backup Ring			NOK	NOK	NOK	NOK	NOK	NOK
d	D	t	Part Number	Part Number	Part Number	Part Number	Part Number	Part Number
155	180	4	GN4157V0	GN4157F0	GN9179O0	GN1016V0	GN1016F0	GN9179O1
160	175		GN4835V0	GN4835F0	GN9180O0	GN6499V0	GN6499F0	GN9180O1
	185		GN4540V0	GN4540F0	GN9181O0	GN1020V0	GN1020F0	GN9181O1
165	180		GN4836V0	GN4836F0	GN9182O0	GN6500V0	GN6500F0	GN9182O1
170			GN4837V0	GN4837F0	GN9183O0	GN6501V0	GN6501F0	GN9183O1
	200		GN4838V0	GN4838F0	GN9184O0	GN6502V0	GN6502F0	GN9184O1
175	190		GN4839V0	GN4839F0	GN9185O0	GN6503V0	GN6503F0	GN9185O1
	200		GN4460V0	GN4460F0	GN9186O0	GN1031V0	GN1031F0	GN9186O1
180			GN4470V0	GN4470F0	GN9187O0	GN6372V0	GN6372F0	GN9187O1
	205		GN4427V0	GN4427F0	GN9188O0	GN1035V0	GN1035F0	GN9188O1
190	200		GN4840V0	GN4840F0	GN9189O0	GN6504V0	GN6504F0	GN9189O1
	210		GN4841V0	GN4841F0	GN9190O0	GN6505V0	GN6505F0	GN9190O1
200	220		GN4385V0	GN4385F0	GN9191O0	GN6276V0	GN6276F0	GN9191O1
	225		GN4560V0	GN4560F0	GN9192O0	GN1050V0	GN1050F0	GN9192O1
204	224		GN4842V0	GN4842F0	GN9193O0	GN6506V0	GN6506F0	GN9193O1
205	220		GN4843V0	GN4843F0	GN9194O0	GN6507V0	GN6507F0	GN9194O1
210	230		GN4627V0	GN4627F0	GN9195O0	GN6352V0	GN6352F0	GN9195O1
220	240		GN4444V0	GN4444F0	GN9196O0	GN6508V0	GN6508F0	GN9196O1
225	245		GN4844V0	GN4844F0	GN9197O0	GN6509V0	GN6509F0	GN9197O1
	250		GN4416V0	GN4416F0	GN9045O0	GN1065V0	GN1065F0	GN9045O1
230			GN4835V0	GN4835F0	GN9047O0	GN6510V0	GN6510F0	GN9047O1
240	260		GN4845V0	GN4845F0	GN9198O0	GN6511V0	GN6511F0	GN9198O1
250	270		GN4459V0	GN4459F0	GN9199O0	GN6512V0	GN6512F0	GN9199O1
	275		GN4191V0	GN4191F0	GN9200O0	GN1078V0	GN1078F0	GN9200O1
255	280		GN4846V0	GN4846F0	GN9201O0	GN6513V0	GN6513F0	GN9201O1
260	285		GN4847V0	GN4847F0	GN9202O0	GN6514V0	GN6514F0	GN9202O1
265	290		GN4848V0	GN4848F0	GN9203O0	GN6318V0	GN6318F0	GN9203O1
	297		GN4849V0	GN4849F0	GN9204O0	GN6515V0	GN6515F0	GN9204O1
270	295	GN4850V0	GN4850F0	GN9205O0	GN6516V0	GN6516F0	GN9205O1	
	300	GN4851V0	GN4851F0	GN9206O0	GN1089V0	GN1089F0	GN9206O1	
275		GN4852V0	GN4852F0	GN9207O0	GN6517V0	GN6517F0	GN9207O1	
280	305	GN4410V0	GN4410F0	GN9208O0	GN6518V0	GN6518F0	GN9208O1	
	312	GN4853V0	GN4853F0	GN9209O0	GN6519V0	GN6519F0	GN9209O1	
290	315	GN4854V0	GN4854F0	GN9210O0	GN6520V0	GN6520F0	GN9210O1	
300	325	GN4855V0	GN4855F0	GN9211O0	GN6521V0	GN6521F0	GN9211O1	
	332	GN4856V0	GN4856F0	GN9212O0	GN6522V0	GN6522F0	GN9212O1	

DLI2TYPE

DUST SEALS FOR OSCILLATING MOVEMENT
NOXLAN (AU)



F

- Please designate NOK Part number and type & size on your order.

(Example) • Type Dimensions DLI2 35 45 4

Type Sign

Nominal Size of Dust Seal
described in order of inner diameter(d), outer diameter(D), and height(h)

• Part Number FD2032F0

- Please check the application range on page D-4 before selecting the type.

Material	NOK U451 + Metal seal ring (SPCC)
-----------------	-----------------------------------

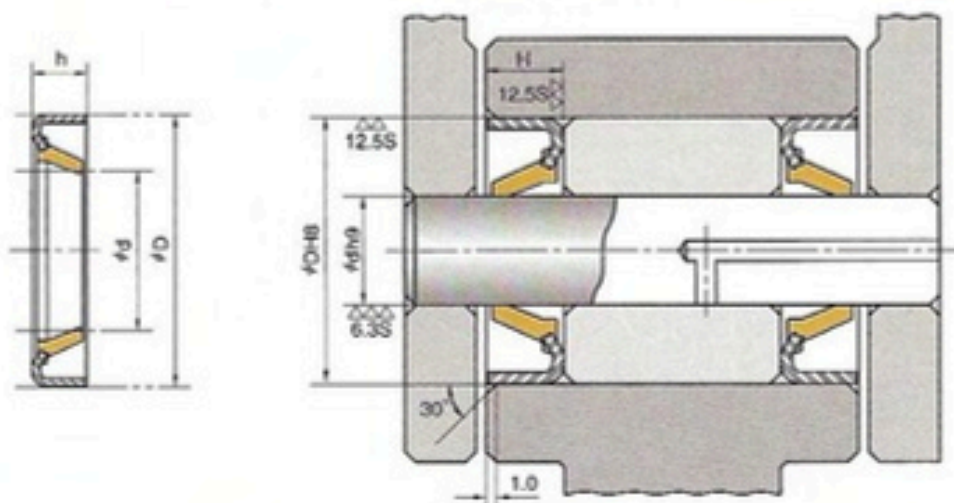

Nominal Size of Dust Seal			Housing dimensions			NOK Part Number
d	D	h	$\varnothing d$	$\varnothing D$	H	
35	45	4	35	45	4 ± 0.1	FD2032F0
40	50	5	40	50	5 ± 0.1	FD9991E1
50	60		50	60		FD9990E1
55	68	6	55	68	6 ± 0.1	FD9996E1
60	75	8	60	75	8 ± 0.1	FD3192E1
65	80		65	80		FD9994E1
70	85		70	85		FD9922E1
75	90		75	90		FD3598E1
85	100		85	100		FD9989E1
95	110		95	110		FD3978F1
110	125		110	125		FD9993E1
120	135		120	135		FD9938E1
125	140		125	140		FD9995E1
140	155		140	155		FD6714E1
145	160	145	160	FD6713E1		

DLI_{TYPE}

DUST SEALS FOR OSCILLATING MOVEMENT
NOXLAN (AU)



- Please designate NOK Part number and type & size on your order.

(Example) • Type Dimensions DLI 140 170 10

Type Sign

Nominal Size of Dust Seal
described in order of inner diameter(d), outer diameter(D), and height(h)

• Part Number FD9969E0

- Please check the application range on page D-4 before selecting the type.

Material	NOK U593 + Metal seal ring (SPCC)
----------	-----------------------------------

DLI TYPE DUST SEALS FOR OSCILLATING MOVEMENT

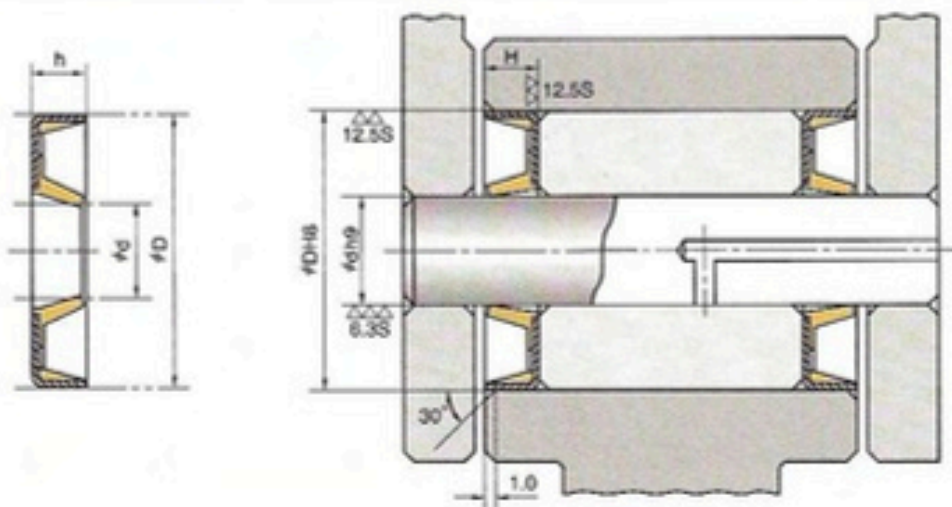

Nominal Size of Dust Seal			Housing dimensions			NOK Part Number
d	D	h	#d	#D	H	
140	170	10	140	170	10 ±0.1	FD9969E0
150	180	11	150	180	11 ±0.1	FD9956E0
160	180	8	160	180	8 ±0.1	FD6712E0
160	190		160	190		FD6710E0
160	190	13	160	190	13 ±0.1	FD4710E0
170	200		170	200		FD4792E0
175	205	8	175	205	8 ±0.1	FD6711E0
180	200		180	200		FD6727E0
180	210	13	180	210	13 ±0.1	FD6759E0
190	210		190	210		FD6728E0
200	220	8	200	220	8 ±0.1	FD6729E0
200	230		200	230		FD6730E0
200	230	13	200	230	13 ±0.1	FD6723E0
220	250		220	250		FD9975E0
220	255	14	220	255	14 ±0.1	FD6774E0
230	255		230	255		FD6793E0
240	270	13	240	270	13 ±0.1	FD6724E0
240	275	14	240	275	14 ±0.1	FD6763E0
250	280	13	250	280	13 ±0.1	FD6725E0

F



HANDLING OF NOK PACKINGS

REMARKS FOR DESIGNING
CYLINDERS G-2

INSTALLATION
OF PACKINGS G 3-9

INSTALLATION
OF DUST SEALS G-9

REMARKS ON ASSEMBLING
CYLINDERS G-10

REMARKS OF STORAGE G-11

G. HANDLING OF NOK PACKINGS

1. REMARKS FOR DESIGNING CYLINDERS

■ CYLINDER TUBE MATERIAL

Use cylinder tube materials specified by the Japan Industrial Standards Hydraulic Cylinder (JIS B 8354). Aluminum alloy, bronze, brass, Monel metal and soft stainless steel may be used for low-pressure applications depending on circumstances. They are not recommended for use over long periods of time due to poor wear resistance. The following table shows the materials specified by JIS.

<Table G-1>

Kinds	Material
Material for tubes	JIS G 3473 (Carbon steel pipe for cylinder tubes.)
	JIS G 3445 (Carbon steel pipe for mechanical structures.)
Material for rods	JIS G 4051 (Carbon steel material for mechanical structures.)

■ INSIDE CYLINDER FACE FINISH AND ROUGHNESS

Generally, a honed finish and a burnishing finish are recommended for the inside face of the cylinder tube. Avoid finishing the face with a pattern aligned in a lateral direction. Specially, under severe lubricating application, burnishing is required.

NOK uses $0.4 - 3.2\mu\text{m Rmax}$ ($0.1 - 0.8\mu\text{m Ra}$) as the inside face finish on a cylinder tube as standard.

■ ROD SURFACE AND ROUGHNESS

$0.8 \sim 1.6\mu\text{m Rmax}$ ($0.2 \sim 0.4\mu\text{m Ra}$) with buff finish, after heat treatment, plating the steel with hard chrome is recommended for rod surface. Never use decorative nickel plating or chrome.

Cylinder rod used for construction machinery is likely to be scored by sands or pebbles, so minimum hardness should be 60 (HrC)

■ ROUGHNESS OF INSIDE FACE OF FITTING GROOVE

Since a rough inside face of the fitting groove affects the sealing of a packing, use a finish value mentioned on the Dimensional Table. In fitting the packing, it is easily scratched, so finish the top end of the groove completely removing any burrs, sharp edges and scars.

■ BEARING CLEARANCE AND EXTRUSION GAP

Since bearing clearance and extrusion gap greatly affect the packing performance, make them as small as possible. (See Dimensional Table for bearing clearance and extrusion gap) Never use a packing in such a way that the packing replaces a bearing.

<Fig. G-1>

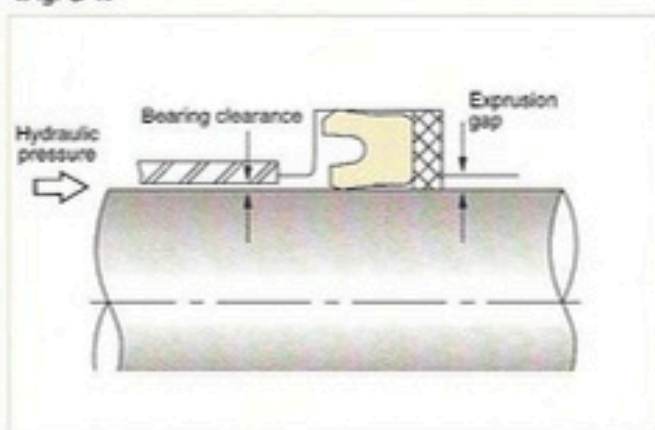

■ DESIGN OF PACKING INSERTION PORT

There is an interference on the I.D. and O.D. of the packing to achieve sealing performance. When installing a packing in a cylinder, the lip of the packing, its most important part, is easily damaged, if the size and construction of the chamfered edge of the insertion port are poor. Especially, apply stepped design to any threaded part as shown in Fig. G-2. (See Dimensional Table for size).

※ Key grooves, splines, etc.

<Fig. G-2>

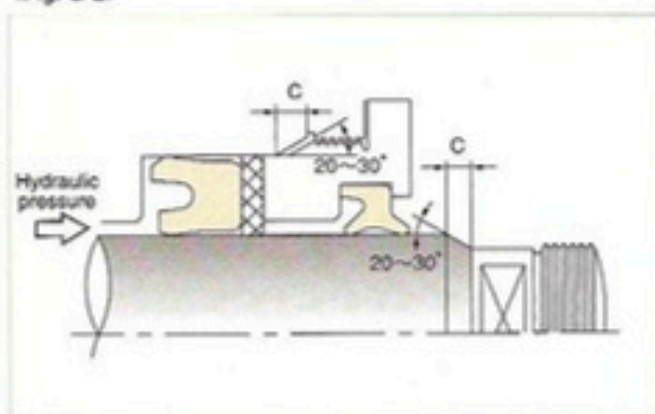

2. INSTALLATION OF PACKINGS

When installing packings, fitting construction differs from one to another depending on the type of packing. The installation method will also vary. It is possible to install a packing with a small profile design and a combination seal in

<table G-2> List of installation methods

Kind	Construction of groove	Noxlan U packing	Nitrile rubber packing	Combined seal	Other packing
Packings for piston seals (Example of installation 2-1)	Integral groove <small>(Note)</small>	Installation method A (Page G-3)	Installation method B (Page G-3)	Installation method C (Page G-4-6)	C packing : Installation example 23 (Page G-8)
	Split groove	A packing can be installed easily. Installation method D (Page G-6)			V packing : Installation example 24 (Page G-8)
Packings for rod seals (Example of installation 2-2)	Integral groove <small>(Note)</small>	Installation method E (Page G-6)	Installation method F (Page G-7)	Installation method G (Page G-7)	Buffer ring : Installation example 25 (Page G-9)
	Split groove	A packing can be installed easily. Installation method H (Page G-7)			

(Example of structure of fitting groove for piston packing)

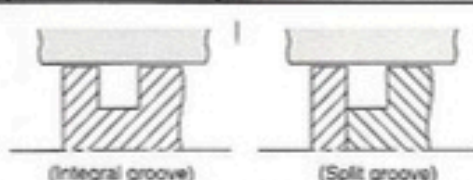

(Example of structure of fitting groove for rod packing)

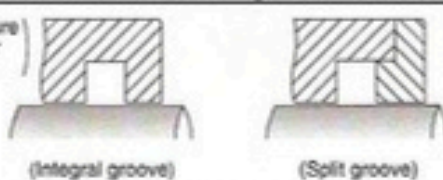

(Note 1) Some of the parts with a small diameter cannot be installed in an integral groove. Kindly check with Dimensional Table.

(Note 2) Install the U packing in such a direction that its lip comes to oil pressure side as it is shown on Fig. G-1 and Fig. G-2 at page G-2.

INSTALLATION EXAMPLE 2-1 PACKINGS FOR PISTON SEALS

METHOD A: INSTALLATION OF A U PACKING IN AN INTEGRAL GROOVE

(MAIN APPLICABLE TYPES: OSI, OUIS, USI)

Some of the parts with a small diameter cannot be installed in an integral groove. Refer to the Dimension Table.

INSTALLATION METHOD

- ① Prepare a pivot with arm which corresponds to the diameter of the piston rod.
- ② First of all, be sure to apply hydraulic oil to ensure easy installation of the packing on the piston rod.

<Fig G-4>

<Fig G-3>



- ③ Fit part of a packing into the installation groove as shown in Fig. G-3.
- ④ Hold the packing with the thumb, then install the pivot into the hole as shown in Fig. G-4.
- ⑤ Rotate the packing once pressing down the arm handle as shown in Fig. G-5.

<Fig G-5>



METHOD B: INSTALLATION OF A NITRILE RUBBER U PACKING IN AN INTEGRAL GROOVE

(MAIN APPLICABLE TYPES: OUHRI, USH)

Some of the parts with a small diameter cannot be installed in an integral groove. Refer to the Dimension Table.

INSTALLATION METHOD

The packing can be easily installed by inserting it in one side of the groove and stretching the other side of the packing to fit in place. (Fig. G-6)

<Fig G-6>



METHOD C: INSTALLATION OF COMBINATION SEALS IN AN INTEGRAL GROOVE
(MAIN APPLICABLE TYPES: OUHRI, USH)

In case of combined seals, correction of Rareflon ring is necessary after installing the back ring and the Rareflon ring into the integral groove. Installation method and correction method are explained below.

INSTALLATION METHOD

<Fig. G-7>

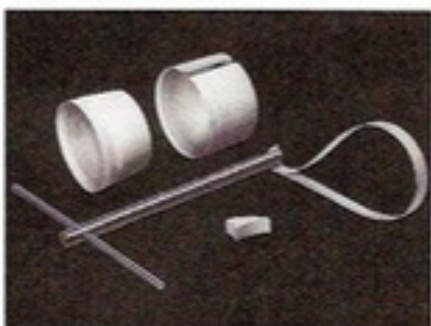

① Prepare a slide tool and push-in tools shown in the figure. Flush clean the inside face of the cylinder and the fitting groove before installation.

<Fig. G-8>



② Install the back ring into the fitting groove. Never over stretch or over bend the back ring when installing it.

<Fig. G-9>

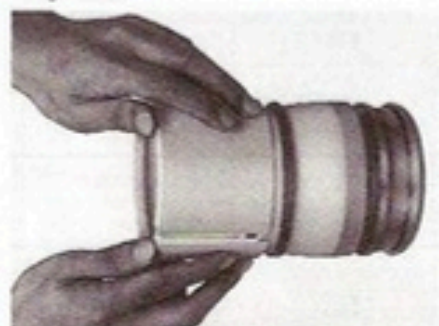

③ Fit the slide tool in the piston. Then quickly push in the Rareflon ring using push-in tool.

[INSTALLATION TOOLS FOR RAREFLON RING]

Shapes of tools used for installation and correction of the Rareflon ring are as follows. Sizes for each part of the push-in and slide tools are according to the sizes of the Rareflon ring (D, T, h) and the piston (φ A, B, H).

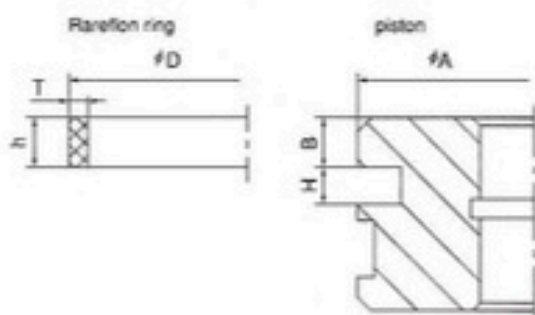

SPG PACKING				SPGO PACKING		SPGW PACKING	
φD	T	φD	T	φD	T	φD	T
30~35.5	1.6	251~400	3.8	20~25	1.0	50~60	2.3
36~60	1.9	401~630	4.1	30~60	1.25	61~120	2.5
61~100	2.4	631~1000	4.5	61~160	2.0	121~240	3.5
101~160	2.9	1001~1500	7.0	161~400	2.5	241~400	4.5
161~250	3.5	1501~1700	8.0	—	—	—	—

<Fig. G-10> Push-in tool (Rareflon)

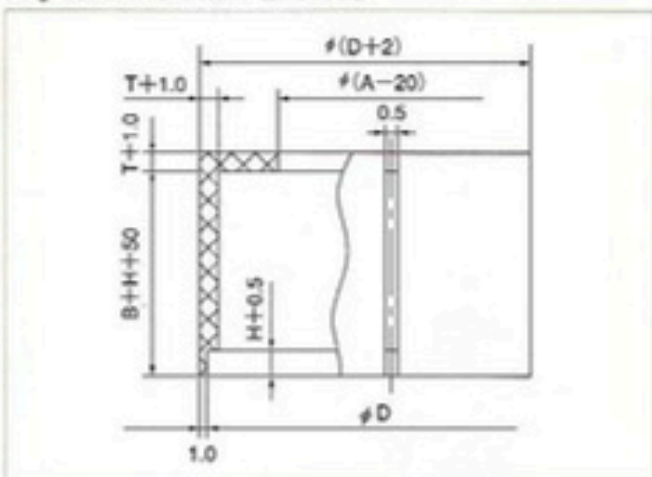

<Fig. G-11> Slide tool (Rareflon or metallic)

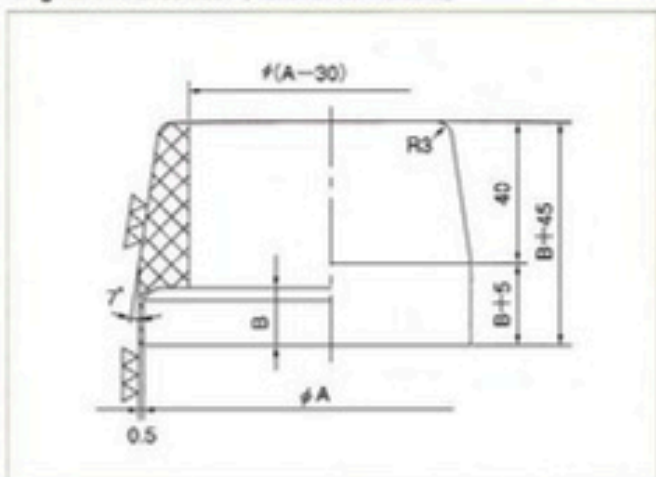

● CORRECTION METHOD OF RAREFLON RING

CORRECTION METHOD 1.

For combination seals, correct the Rareflon ring after installing the back ring and the Rareflon ring in the fitting groove. For

SPGW packings, carry out the correction. On the other hand, carry out correction according to the correction method 2 for packings whose nominal numbers exceed 400.

<Fig. G-12>

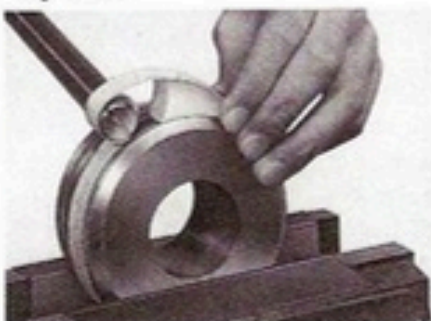

① Prepare a twist bar and adapter as shown in the figure. Set the twist bar and adapter as shown, then set the Rareflon ring in the center of the band.

<Fig. G-13>

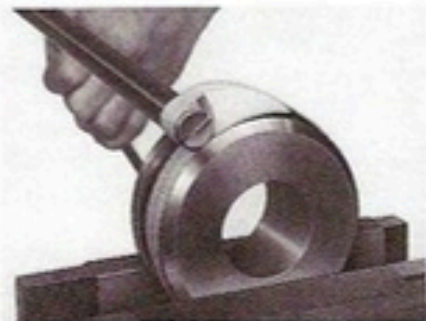

② Hold for 10 seconds or more.

<Fig. G-14>



③ Installation is completed by the above steps. The internal and external circumference faces of the Rareflon ring affect sealing performance, so be careful not to scratch the ring.

[JIG FOR CORRECTION METHOD 1]

<Fig. G-15> Adapter (Rareflon)

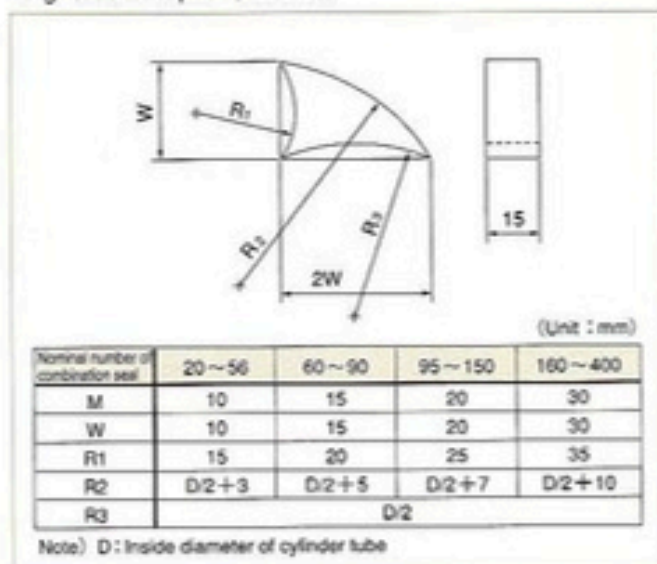

<Fig. G-16> Twist bar (Metal and Polyester band with canvas)

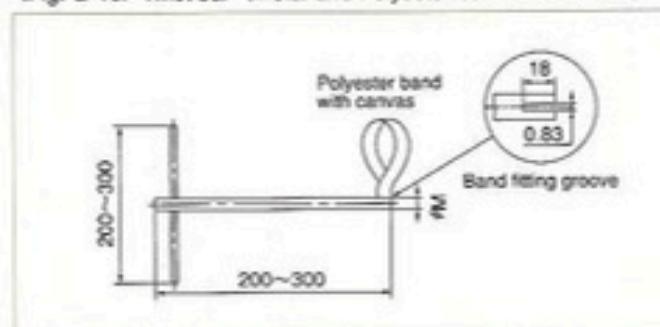

Push-in jig, slide jig and adapter are manufactured by NOK. Kindly place order with us.

CORRECTION METHOD 2.

<Fig. G-17>

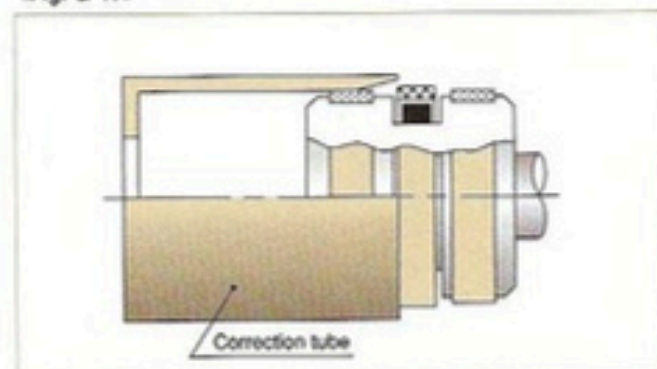

- ① Prepare a correction tube shown in Fig. G-17
- ② Insert a piston after applying hydraulic oil (oil actually used on the engine) and pull the piston mount after having left it there for about 10 seconds.

<Fig. G-18> Correction tube (metal)

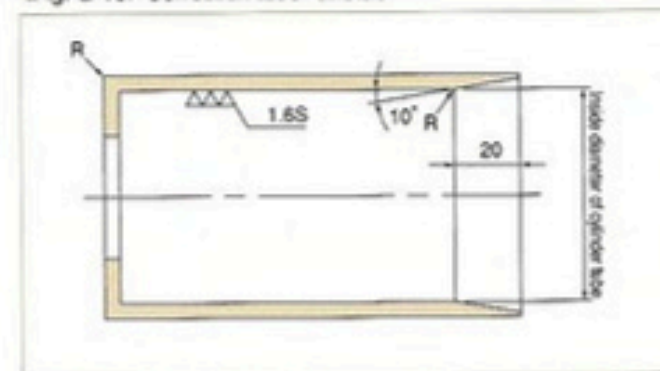

● SPGC TYPE PACKINGS

For SPGC packings having inside diameter below $\phi 50$, use divided grooves generally. When the divided groove is not available or for inside diameter of the cylinder type $\phi 50$ or more, first install O-ring in the fitting groove and then install the Rareflon ring with a tool shown in the figure.

D	F
-Below 56	1.3
58-160	1.5
165-400	2.0

<Fig. G-19>

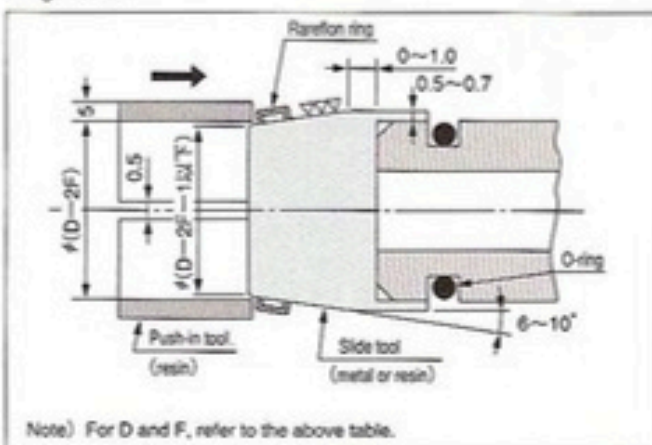

● SPGI TYPE PACKINGS

SPGI packings can be installed easily by hand in the same way as nitrile rubber U-packings. (Refer to INSTALLATION METHOD B on Page G-3.)

■ METHOD D: INSTALLATION INTO DIVIDED GROOVE

No special tool is required for installation into a divided groove. Packings can be easily installed by hand.

Be careful not to scratch the packing by the fitting groove or angle.

EXAMPLE OF INSTALLING 2-2 PACKINGS FOR ROD SEALS

■ METHOD E: INSTALLATION OF NOXLAN U PACKING INTO INTEGRAL GROOVE (MAIN APPLICABLE TYPES: ISI, USI)

Some of the parts with a small diameter cannot be installed in an integral groove. Refer to the Dimension Table.

INSTALLATION METHOD

- ① When using a backup ring together, first install the buffer ring into the fitting groove as shown in Fig. G-20.
- ② Prepare special plugs and push-in rods suitable for respective diameters. Use soft resin for material and it is necessary to make the upper parts of the tools slide into the packings smoothly. Fit the packing by hand as shown on Fig. G-21.
- ③ When the uppermost part of the packing is pushed in with a special push-in rod, the packing can be installed easily in the fitting groove, making a "Click" noise.

Processes shown in Fig. G-21 and Fig. G-22 should be completed as quickly as possible in order to prevent a permanent deformation of the packing. Be careful not to stop or interrupt the operation in the middle.

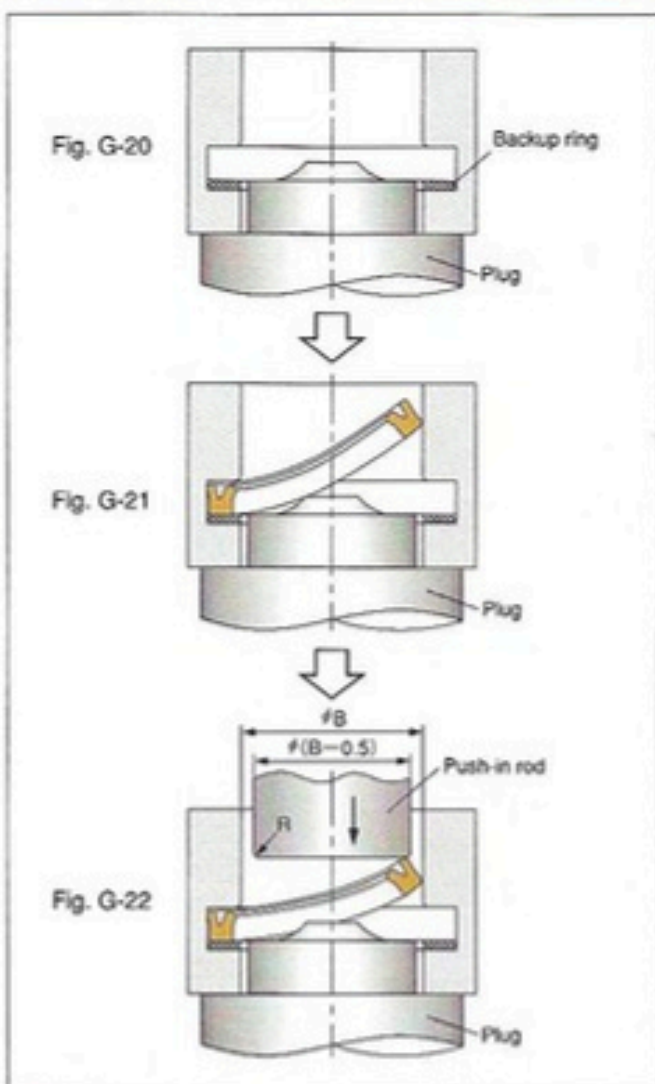

METHOD F: INSTALLATION OF NITRILE RUBBER U PACKING INTO INTEGRAL GROOVE

(MAIN APPLICABLE TYPES: IUH, USH)

Some of the packings with a small diameter cannot be installed into an integral groove. Kindly check it with the Dimensional Table.

INSTALLATION METHOD

- ① Deform the packing into a heart-shape with the fingers as shown in Fig G-23. At this moment, be careful not to "scratch" the packing with "nails".

Install the packing as quickly as possible in order to prevent permanent deformation.

- ② The packing inserted in the fitting groove may get a little warped, so correct it with a finger or spatula.

<Fig. G-23>



METHOD G: INSTALLATION OF COMBINATION SEAL INTO INTEGRAL FITTING GROOVE

(MAIN APPLICABLE TYPES: SPN, SPNO)

The combination seal cannot be installed into an integral groove on a rod having its rod diameter below $\phi 50$.

In the case where the rod diameter exceeds $\phi 50$, take the following steps to install the combination seal.

INSTALLATION METHOD

- ① Insert the back ring into the fitting groove.
- ② Prepare special plugs and push-in rods suitable for respective diameters.
- ③ Install the Rareflon ring into one side of the fitting groove as shown in the Fig. G-24 and push it in with the push-in rod.

Do not twist or deform the Rareflon ring into a heart shape.

<Fig. G-24>

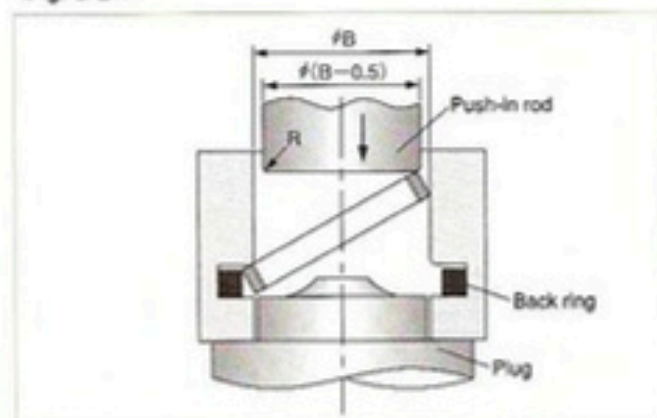

METHOD H: INSTALLATION IN SPLIT GROOVE

(Applicable to packings for rod seals in general)

U PACKINGS

No special tools are required to install U packings from the heel. All packings are easily inserted. When installing U packings from the lip, be particularly careful not to scratch them with the top end of the fitting groove. U packing can be installed by another method using a bushing for assembly and a push-in rod as shown in the Fig. G-25.

INSTALLATION OF COMBINATION SEAL

For installation of SPNC packing, pre-assemble the back ring (O-ring) and Rareflon ring before installation.

The back ring and rareflon ring can be installed separately with SPN and SPNO types.

<Fig. G-25>

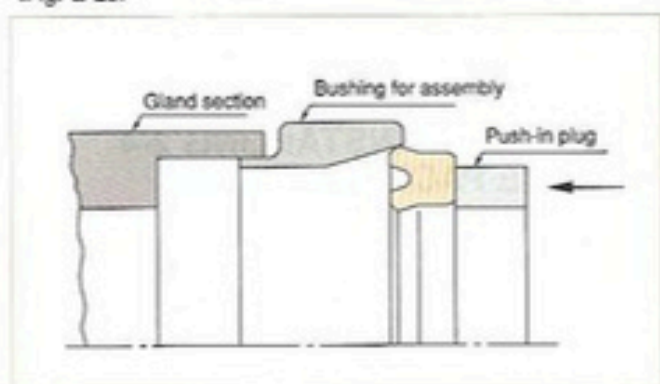

EXAMPLE OF INSTALLING 2-3 C-SHAPE PACKINGS

(Applicable types: CPI, CPH)

Design fitting groove of C-shape packing so that the packing is tightened properly as shown in the Figs. G-25-1 (a), (b) and (c). Deformation as shown in Fig. G-26-2 occurs when the packing is over tightened.

<Fig. G-26-1>

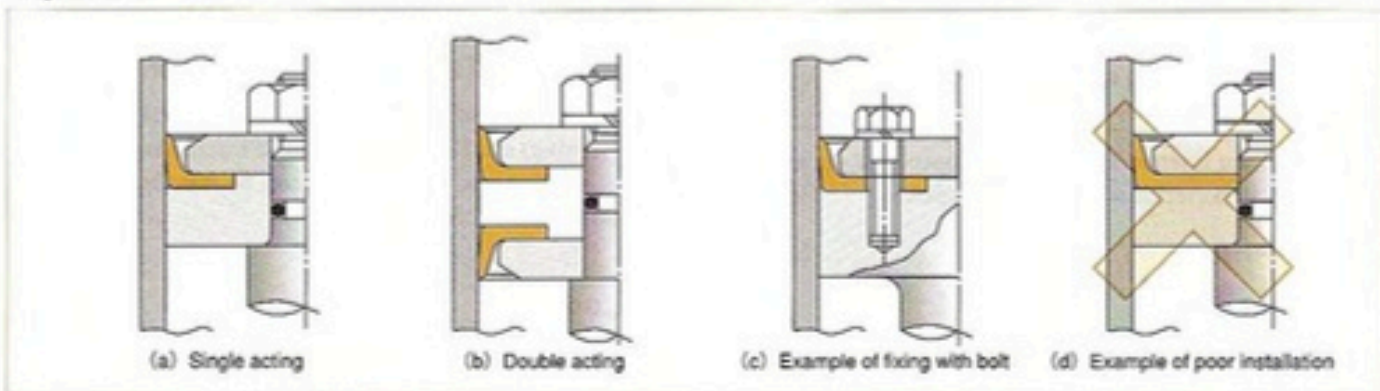

<Fig. G-26-2>

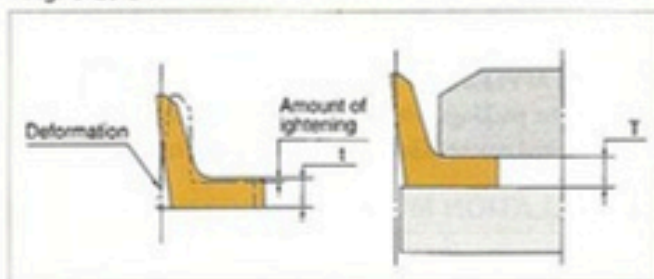

EXAMPLE OF INSTALLING 2-4 V-SHAPE PACKINGS

(Main applicable types: V99F, V96H)

Some of the parts with a small diameter cannot be installed in an integral groove. Refer to the Dimension Table.

INSTALLATION METHOD

- ① Clean inside the gland well and apply grease or hydraulic oil lightly.
- ② Apply grease or hydraulic oil on the packing face, securely insert packings one by one to avoid twisting or warping.
- ③ When glands of V-shape packings for rod seals are as shown on the Fig. G-27, be careful not to "scratch" the top end of the lip by threads or chamfered part. Make sure there is no "turnover" or "burrs" on the chamfered part and then insert the packing.

- ④ Tighten the "packing holder" just enough to fix the packing. Over tightening will increase friction and wear of the packing and shorten its life.
- ⑤ The fabric reinforced V-shape packing may be compressed by service pressure while in use and shift in the gland to cause leakage. Apply additional tightening of the packing holder and then make adjustment. The amount of tightening must be within the limit given in Fig. G-28. When only using rubber V-shape packing, do not apply additional packing.

<Fig. G-28> Max. allowable tightening

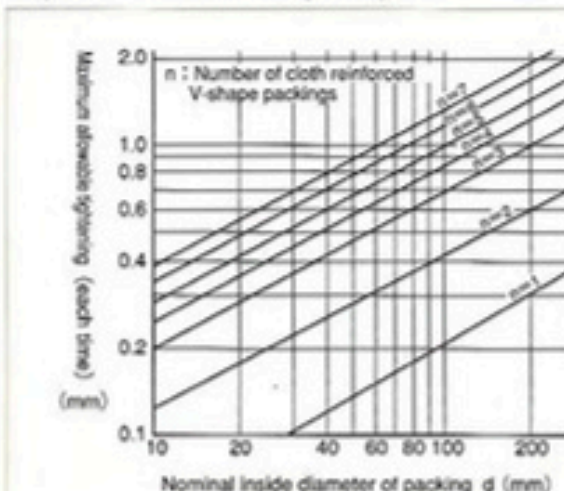

<Fig. G-27>

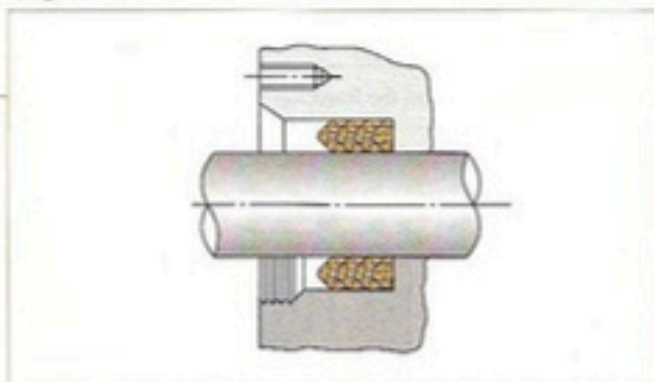

- When fabric reinforced rubber V-shape packing is used in combination with rubber V-shape packing, do not count the number of rubber V-shape packings.

EXAMPLE OF INSTALLING 2-5 BUFFER RINGS

(Applicable types: HBTS, HBY)

Buffer rings can be installed into integral grooves.

● HBTS

As same steps for SPN packing installation, install HBTS packings following to the installation method in page G-7.

Pay attention to the direction of the Rareflon ring as shown in Fig. G-29.

<Fig. G-29>

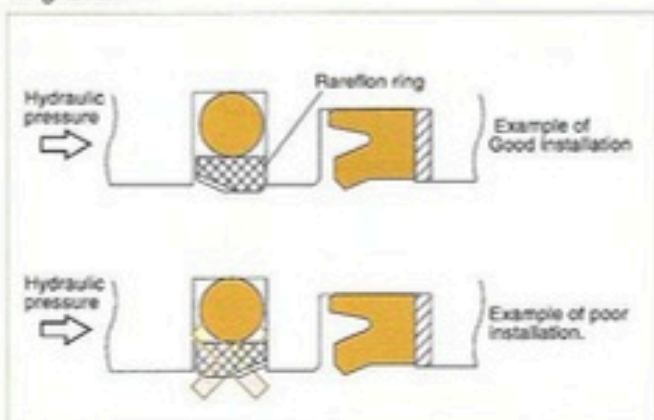

● HBY

Install the packing as deforming into a heart-shape with fingers. Then assembled the back ring.

Pay attention to the direction of the Rareflon backup ring as shown in Fig. G-30.

<Fig. G-30>

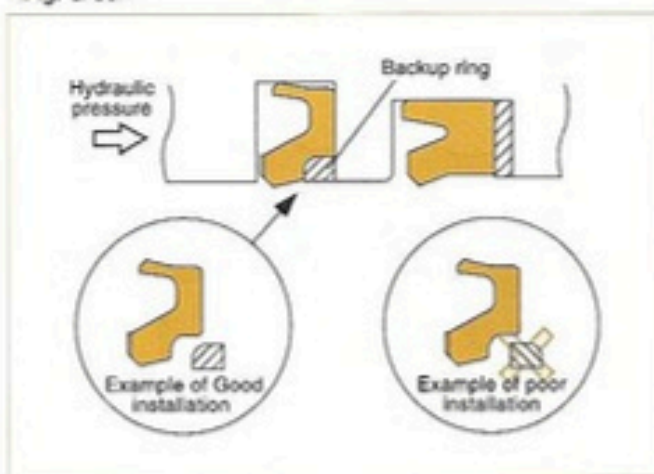

3. INSTALLATION OF DUST SEALS

(Applicable to dust-seals in general)

● DSI, LBI, LBH

As a dust seal is a single part, deform it into a heart shape and install it carefully being careful not to "scratch" it with "fingers".

● DKI, DWI, DWIR, DKBI, DKH, DKB

Dust seals are pressed in a fitting groove. Prepare press-in tools as shown in the following figure.

INSTALLATION METHOD

- ① Set the dust seal horizontally to the housing hole.
- ② With a press, carefully push in the dust seal using installation tools so as not to deform the dust seal lip nor to incline the dust seal.

<Fig. G-31>

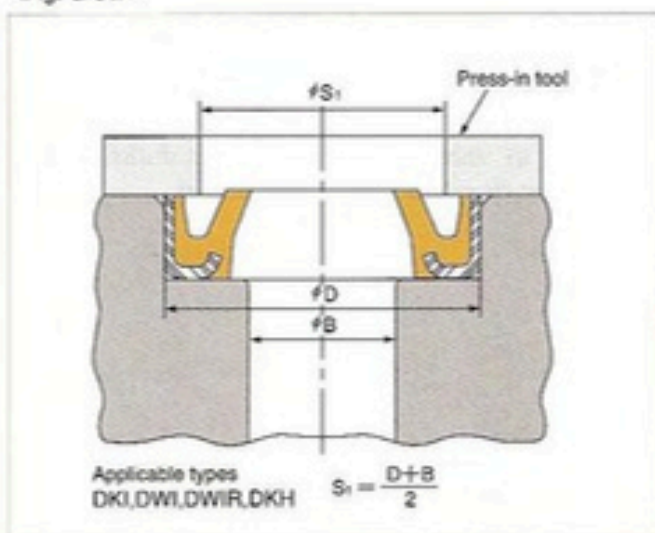

<Fig. G-32>

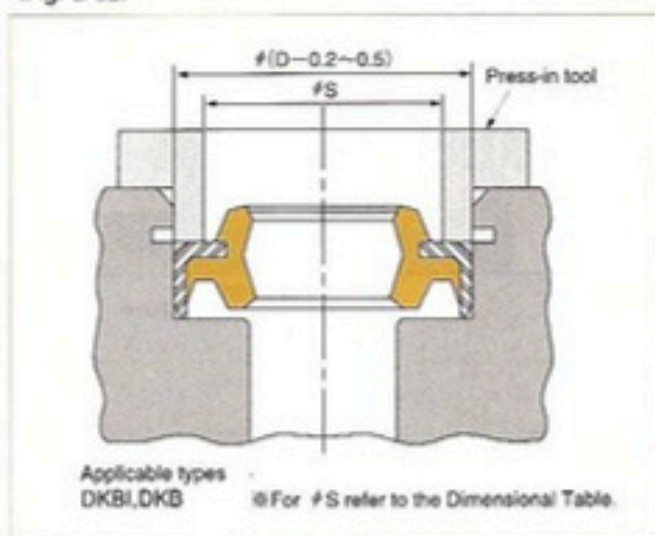

4. REMARKS ON ASSEMBLING CYLINDERS

Sealing performance of a packing is greatly influenced by the method of assembling a cylinder. Please check the following points.

1. Eliminate foreign materials from the internal face of the cylinder tube and interior of pipes.
2. When using packings from storage, do not use those that have foreign material such as dust, sand, etc., as this will cause leakage.
3. Apply hydraulic oil (the same oil used in the machine) to the packing, gland, rod surface and internal face of the cylinder, then assemble the cylinder.
4. Put a protective cover over the lip of the packing so that it does not directly contact the "thread" and steps.
5. When it is necessary to let the lip of the packing pass through a hydraulic pressure port as in Fig. G-34, lightly push the lip with a spatula (resin). This prevents damage to the lip of the packing by the chamfer of the port. Chamfer as shown in Fig. G-35 when drilling a hole directly on the cylinder for a hydraulic port.

<Fig. G-34>

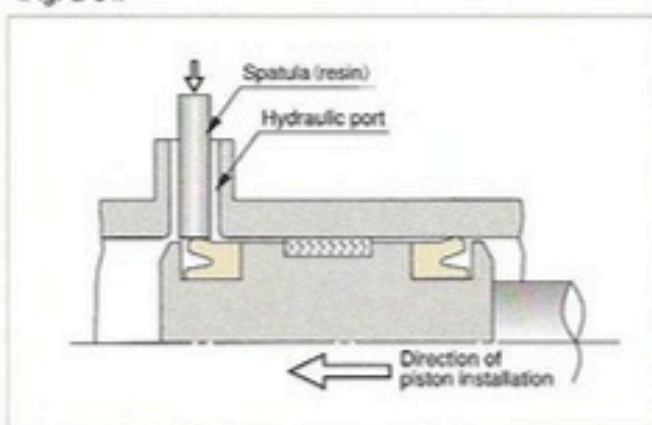

<Fig. G-35>

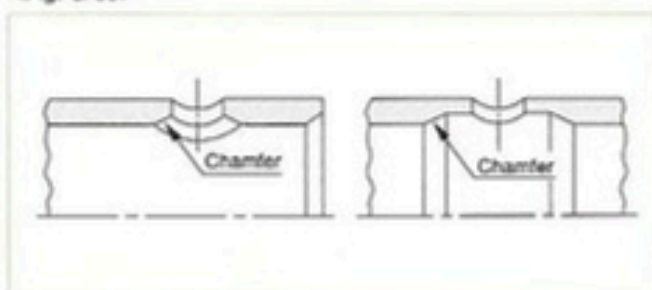

<Fig. G-33>

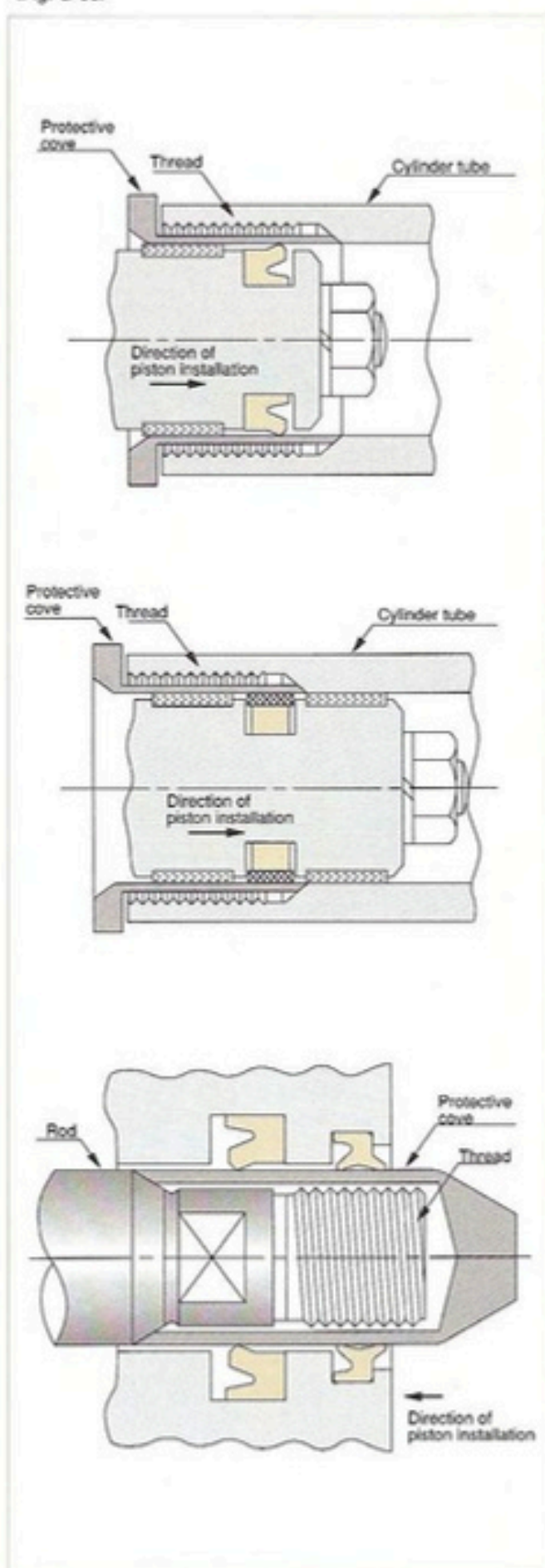

5. REMARKS OF STORAGE

When storing packings, please check the following points.

1. Do not open the packing unnecessarily. "Dust" may stick to the packing or scratch it.
2. Avoid exposure to direct sunlight and store in a cool place. Ultraviolet light and humidity may sometimes promote deterioration and dimensional change of rubber and resin material.
3. When storing products already unpacked, be careful that foreign materials do not stick or become embedded. Store them in their original condition, in tightly sealed polyamide to prevent dimensional change resulting from humidity.
4. Do not replace packings near any heat source such as a boiler, stove, etc. Heat may deteriorate the material.
5. Do not place packings near electric motors or equipment generating ozone.
6. Avoid hanging packings with a nail, wire or suspending them with a string as this may cause deformation and scratches on the top end of the lip.
7. Sometimes, color changes or white powder appears on the surface of packings (blooming phenomenon). This will not affect the function of the packing.
8. Rareflon rings of combination seals may be easily scratched if dropped or impacted by an external force. Be careful when handling.

G

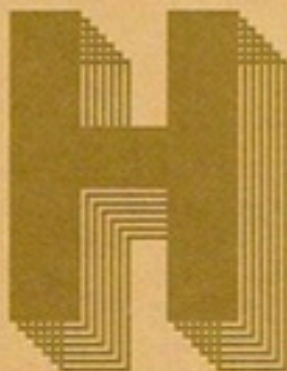

WHEN LEAKAGE OCCURS

Cause of Leakage H 2-3

Failure Mode and
Countermeasures H 4-12

H WHEN LEAKAGE OCCURRED

CAUSE OF LEAKAGE

In this chapter, we will introduce the main causes of oil leakage from the sealing and examples of countermeasure. When oil leakage is observed, first check where the leakage occurred. Sometimes a deposit of grease is mistaken for oil leakage. If leakage from the seal is confirmed, see if there is any abnormalities with the seal contact area. The following examples of leakage are classified into two groups: Cases where there is no abnormalities with the seal contact area. And cases where abnormalities are observed with the seal contact area.



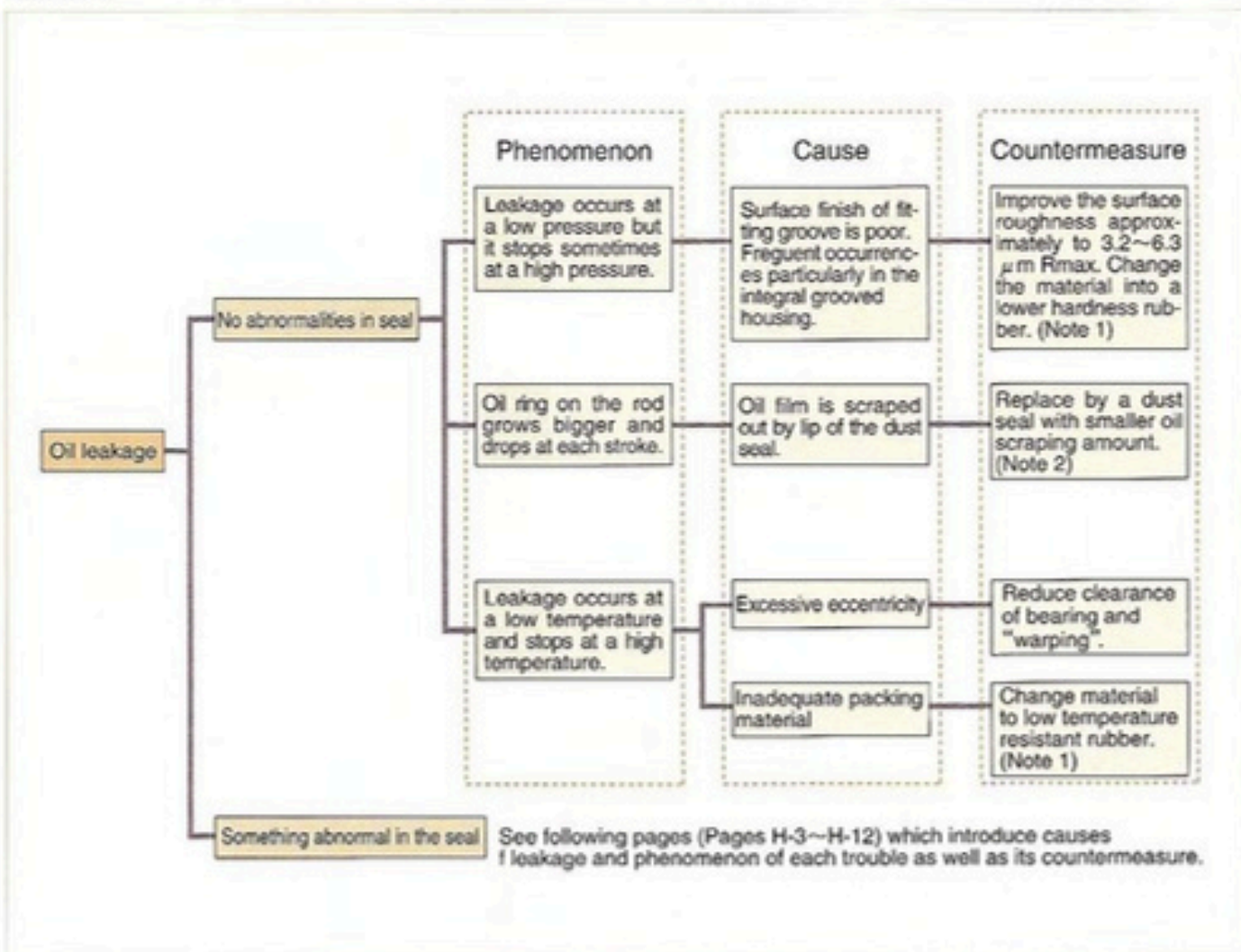







<Table H-1>











Note 1) As it is necessary to take other conditions into account, kindly consult with NOK separately.

Note 2) As anti-dust performance and sealing performance are of contradictory nature, it is necessary to take a balance according to their respective importance.



NITRILE RUBBER PACKINGS

Appearance		Cause	Countermeasure
Fact	Condition		
Hardening	  <p>Hardening of the whole sliding face. Glazing and cracks on the surface. Push with a finger and cracks appear.</p>	<ul style="list-style-type: none"> ● Heat generation by high speed or excessive internal pressure 	<ul style="list-style-type: none"> ● In case of a piston, change to SPG (SPGW). ● In case of rod, use buffer ring together.
	  <p>The whole packin hardens and lip deflects greatly and when bent with a finger, cracks appear.</p>	<ul style="list-style-type: none"> ● High oil temperature <hr/> <ul style="list-style-type: none"> ● Influence of oil <ul style="list-style-type: none"> ● Incompatibility of oil and rubber material ● Deterioration of oil 	<ul style="list-style-type: none"> ● Lower oil temperature or change to heat resistant material (fluorine rubber) <hr/> <ul style="list-style-type: none"> ● Change to oil resistant rubber material ● Renew oil.
Wear	  <p>The sliding surface shows wear with gloss.</p>	<ul style="list-style-type: none"> ● Sliding was extremely short stroke and caused insufficient lubrication. <hr/> <ul style="list-style-type: none"> ● Roughness of sliding face is inappropriate (too good) 	<ul style="list-style-type: none"> ● In case of a piston, change to SPG (SPGW). ● In case of rod, use buffer ring together. <hr/> <ul style="list-style-type: none"> ● Change to recommended roughness.
	  <p>The lip contact width continuously differs on the circumference, and the position of maximum and minimum width are roughly symmetrical.</p>	<ul style="list-style-type: none"> ● Eccentricity of rod and cylinder head and cylinder and piston head. 	<ul style="list-style-type: none"> ● Make eccentricity of installation within the tolerance of packings.
	  <p>Abnormal wear observed at one portion of the circumference of the sliding lip (matching the direction of lateral load).</p>	<ul style="list-style-type: none"> ● Abnormal wear of wear ring (piston) and bearing by excessive lateral load. 	<ul style="list-style-type: none"> ● Change wear ring and bearing material to those which can withstand a heavy load.





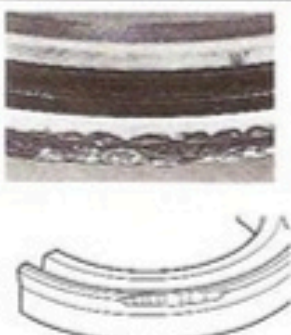
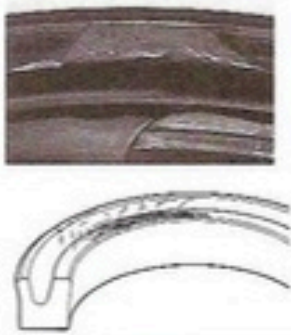
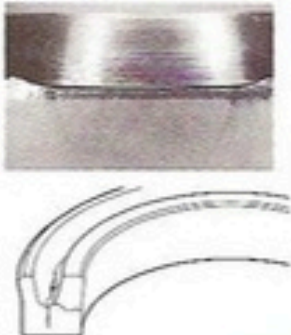

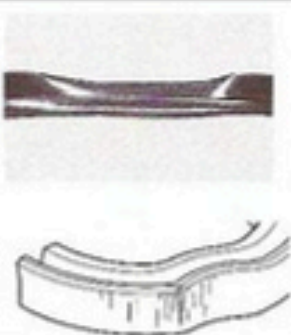

NITRILE RUBBER PACKINGS

Appearance		Cause	Countermeasure
Fact	Condition		
Scratch	 <p>Partial cut, dent on the edge of the lip</p> 	<ul style="list-style-type: none"> ● By external force such as by hanging on a nail or wire for storage. ● Insufficient chamfering of the mating material when fitting. ● By driver, etc. when fitting 	<ul style="list-style-type: none"> ● Improvement to storage method ● Increase chamfering of the mating material and make it smooth so as not to cause overturn. ● Use fitting tool.
	 <p>Scratch on sliding face.</p> 	<ul style="list-style-type: none"> ● There was a scar on the mating sliding face. ● Due to "overturn" of chamfered part of the mating material at the time of fitting ● By embedded foreign material 	<ul style="list-style-type: none"> ● Check fully before fitting. ● Increase chamfering of the mating material and make it smooth so as not to cause "overturn". ● Make sure to clean.
	 <p>Whole packing is softened</p> 	<ul style="list-style-type: none"> ● Oil and rubber material are incompatible. ● Influence of cleaning liquid 	<ul style="list-style-type: none"> ● Change to oil resistant material. ● Change cleaning liquid. ● Remove cleaning liquid.
Dents	 <p>Small dents on sliding face.</p> 	<ul style="list-style-type: none"> ● Dust and cuttings embedded in the sliding face due to poor cleaning. ● Embedded foreign material or embedded oxidized products due to oxidation. 	<ul style="list-style-type: none"> ● Remove foreign materials sticking to the equipment. ● Renew oil.











NITRILE RUBBER PACKINGS

Appearance		Cause	Countermeasure
Fact	Condition		
Failure	 <p>A part of the packing lip is form in an arc shape (piston seal).</p>	<ul style="list-style-type: none"> ● Excessive back pressure occurs. 	<ul style="list-style-type: none"> ● Change to OUHR. ● Change to SPG (SPGW).
	 <p>The lip and groove are partly carbonized or melted.</p>	<ul style="list-style-type: none"> ● Burning by adiabatic compression of the residual air. 	<ul style="list-style-type: none"> ● Countermeasures shown at pages I-12 and I-13.
	 <p>Cracks grew from the groove of packing.</p>	<ul style="list-style-type: none"> ● Fatigue failure due to frequent impulse pressure. 	<ul style="list-style-type: none"> ● In case of a rod, use buffer ring together. ● In case of a piston, change to SPG (SPGW).
		<ul style="list-style-type: none"> ● Breaking due to starting at low temperature. 	<ul style="list-style-type: none"> ● Change to packing of low temperature resistant material.
	 <p>The whole part of the lip of the sliding part is broken.</p>	<ul style="list-style-type: none"> ● Deterioration of the packing material. 	<ul style="list-style-type: none"> ● Change to heat resistant and oil resistant rubber material
		<ul style="list-style-type: none"> ● Deterioration of oil 	<ul style="list-style-type: none"> ● Renew oil.
 <p>Broken at one or two places on the circumference of the packing.</p>	<ul style="list-style-type: none"> ● Packing installed as twisted. ● Assembled with improper packing installation. 	<ul style="list-style-type: none"> ● Improve the method and tools of installation. 	











NITRILE RUBBER PACKINGS

Fact	Appearance		Cause	Countermeasure	
	Condition				
Failure		Fine cracks on all over the packing surface.	<ul style="list-style-type: none"> ● Ozone cracks by exposing packing to air too long. 	<ul style="list-style-type: none"> ● Not to open package unnecessarily but to store it in a cold place as sealed. 	
				<ul style="list-style-type: none"> ● Ozone cracks by leaving installed with piston. 	<ul style="list-style-type: none"> ● Not to leave packing installed with piston but to assemble into cylinder as quickly as possible.
		The packing heel on the sliding side is worn off.	<ul style="list-style-type: none"> ● Extrusion gap was too big. 	<ul style="list-style-type: none"> ● Reduce extrusion gap ● Use a backup ring. 	
				<ul style="list-style-type: none"> ● Bearing worn too much causing a large gap. 	<ul style="list-style-type: none"> ● Change bearing material to an appropriate material.
			<ul style="list-style-type: none"> ● Too much pressure. 	<ul style="list-style-type: none"> ● Use a backup ring together and reselect the packing. ● Use buffer ring together. 	
		The packing heel at static side is torn off.	<ul style="list-style-type: none"> ● The construction of installation part is inappropriate 	<ul style="list-style-type: none"> ● Correct chamfering 	
				<ul style="list-style-type: none"> ● Gap generated due to insufficient rigidity of support plate. 	<ul style="list-style-type: none"> ● Improve rigidity of support plate
			<ul style="list-style-type: none"> ● Inappropriate backup ring. 	<ul style="list-style-type: none"> ● Correct the size of backup ring. ● Change backup ring material to appropriate one. 	
		Extrusion at both the packing heel and the backup ring.	<ul style="list-style-type: none"> ● Excessive extrusion gap 	<ul style="list-style-type: none"> ● Reduce extrusion gap 	
				<ul style="list-style-type: none"> ● Inappropriate backup ring 	<ul style="list-style-type: none"> ● Change backup ring to that of a more rigid material. ● Make thickness of the backup ring thicker. ● Use buffer ring together.



NOXLAN PACKINGS

Fact	Appearance		Cause	Countermeasure
	Condition			
Wear		Wear with gloss on the sliding surface.	● Sliding was extremely short stroke and caused insufficient lubrication.	● In case of piston, change to SPG.
			● Pressure higher than 3MPa is always exerted.	● In case of piston, change to SPG.
Wear		Abnormal wear at part of the circumference of the sliding lip (matching the direction of lateral load).	● Abnormal wear of wear ring (piston) and bearing by excessive lateral load.	● Change wear ring and bearing material to those which can withstand a heavy load.
				
Scars		Partial cut, dent on the edge of the lip	● By external force such as by hanging on a nail or wire for storage.	● Improvement to storage method
			● Cut and dent due to "overturn" of the mating material when fitting.	● Increase chamfering of the mating material and make it smooth so as not to cause "overturn".
		Scratches on sliding face.	● Cut and dent by driver, etc. when fitting	● Use fitting tool.
			● There was a "scar" on the mating sliding face.	● Check fully before fitting.
Scars		Generation of "scratches" at edge of the lip.	● Due to "overturn" of chamfered part of the mating material at the time of fitting	● Increase chamfering of the mating material and make it smooth so as not to cause "overturn".
			● By embedded foreign material	● Make sure to clean.
		Generation of "scratches" at edge of the lip.	● Due to "overturn" of chamfered part of the mating material at the time of fitting	● Chamfer the mating material according to the Dimensional Table and make it smooth so as not to cause "overturn".

NOXLAN PACKINGS

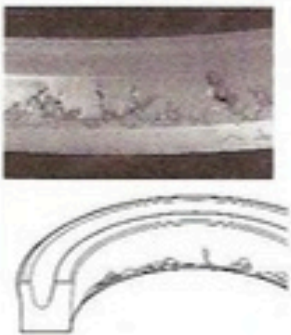

Fact	Appearance		Cause	Countermeasure
	Condition			
Deterioration		Gloss and cracks on the surface. Push with a finger and cracks appear.	● Excessive rise of oil temperature.	● Lower oil temperature or change to heat resistant material (fluorine rubber)
			● Incompatibility of oil and rubber material.	● Check oil resistance of the packing and change the material of the packing or the hydraulic oil.
		Rubber loses elasticity and breaking off.	● Deterioration of oil	● Renew oil.
			● Excessive rise of oil temperature.	● Change to rubber material with better heat and oil resistance.
Extrusion		Trace of small dent exists from the heel side of the sliding surface to the edge of the lip and a thin filmlike extrusion fraction is left on the heel part.	● Incompatibility of oil and rubber material.	● Check oil resistance of the packing and change the material of the packing or the hydraulic oil.
			● Deterioration of oil.	● Renew oil
		The heel part of the sliding side shows extrusion and change of color into red all over.	● Excessive extrusion gap	● Reduce the gap. ● Use backup ring together.
			● Excessive pressure	● Use backup ring together and re-select packing. ● Use buffer ring together
			● Excessive extrusion gap	● Reduce the extrusion gap. ● Use backup ring together.
		● Increase of bearing gap due to a significant wear of bearing.	● Change bearing material to an appropriate one.	
	The out side of the pure PTFE backup ring is partially torn off, from where packing has extruded and deformed.	● Excessive pressure	● Use backup ring together and re-select packing. ● Use buffer ring together.	
		● Change of color into red is due to coloring effect of the color of hydraulic oil and no change in material nature. Therefore, there is no problem to use it as it is.		
			● Insufficient strength and wear resistance of the backup ring.	● Change material of backup ring to 19YF or 80NP.

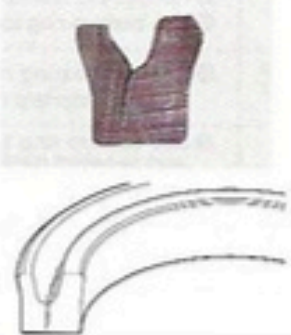
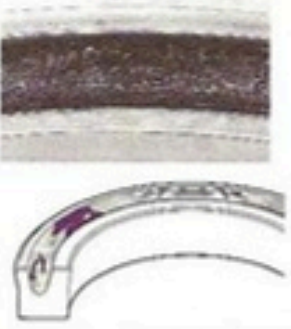
NOXLAN PACKINGS

Appearance		Cause	Countermeasure
Fact	Condition		
Failure	 <p>The whole part of the lip of the sliding part is torn off.</p>	<ul style="list-style-type: none"> ● Excessive rise of oil temperature. 	<ul style="list-style-type: none"> ● Change rubber material to the one with better heat resistance.
		<ul style="list-style-type: none"> ● Incompatibility of oil and rubber material Deterioration of oil. 	<ul style="list-style-type: none"> ● Check oil resistance of the packing and change the material of the packing or the hydraulic oil.
	 <p>Heel part on sliding side is torn off.</p>	<ul style="list-style-type: none"> ● Excessive extrusion gap. 	<ul style="list-style-type: none"> ● Reduce the gap. ● Use backup ring together.
		<ul style="list-style-type: none"> ● Increase of bearing gap due to great wear of bearing. 	<ul style="list-style-type: none"> ● Change bearing material to an appropriate one.
		<ul style="list-style-type: none"> ● Excessive pressure. 	<ul style="list-style-type: none"> ● Use backup ring together and re-select packing.
	 <p>The sliding lip of packing is extruded in an arc shape or torn off. (piston seal)</p>	<ul style="list-style-type: none"> ● Generation of excessive back pressure. 	<ul style="list-style-type: none"> ● In case of Noxlan packing, change to OUIS. ● Change to combination seal (SPG, SPGW).
	 <p>Generation of cracks starting from the groove of U packing.</p>	<ul style="list-style-type: none"> ● Fatigue failure due to frequent shock pressure. 	<ul style="list-style-type: none"> ● In case of a rod packing, use buffer ring together.
Burning	 <p>Groove of U packing is partially burned and carbonized.</p>	<ul style="list-style-type: none"> ● Burning by adiabatic compression of the residual air. 	<ul style="list-style-type: none"> ● Countermeasures shown at pages I-12 and I-13.













FAILURE MODE AND COUNTERMEASURES

NOXLAN PACKINGS

Appearance		Cause	Countermeasure
Fact	Condition		
Deformation	  <p>Deformation and cuts at 2 places on the out side of the packing.</p>	<ul style="list-style-type: none"> ● Poor installation in the integrated groove 	<ul style="list-style-type: none"> ● Shown at page G-6.

H

COMBINATION SEALS AND PARTS CONNECTED WITH SEALS

Appearance		Cause	Countermeasure
Fact	Condition		
	  Heavy scratches on sliding surface.	<ul style="list-style-type: none"> ● There was a "scar" on the mating sliding face. ● Due to "burr" and "overturn" of chamfered part of the mating material at the time of fitting. ● By embedded foreign material such as metal powder, etc. 	<ul style="list-style-type: none"> ● Check fully before fitting. ● Increase chamfering of the mating material according to Dimensional Table and make it smooth so as not to cause "bur" and "overturn". ● Remove foreign material. ● Provide contamination seals (KZT) on both sides of the packing.
	  Film-like extrusion on the sliding surface of the seal.	<ul style="list-style-type: none"> ● Excessive extrusion gap 	<ul style="list-style-type: none"> ● Reduce extrusion gap ● Change material to the one with higher rigidity ● Change to SPGW with backup ring.
Failure	  Thin film-like extrusion at the sliding surface of the backup ring.	<ul style="list-style-type: none"> ● Excessive extrusion gap ● High pressure 	<ul style="list-style-type: none"> ● Reduce extrusion gap ● Change the material of the backup ring to the one with higher rigidity.
	  A part of circumference of the seal is abnormally worn (matching with the direction of lateral load)	<ul style="list-style-type: none"> ● Eccentricity due to abnormal wear of wear ring and bearing caused by an excessive lateral load. ● Sliding face of the mating material is partly rough. 	<ul style="list-style-type: none"> ● Change the material of wear ring and of bearing to the one that can resist against the lateral load. ● Finish roughness uniformly (Recommended value: $0.4 \sim 3.2 \mu\text{m Rmax}$).
	  One side of the wear ring is carbonized.	<ul style="list-style-type: none"> ● Burning by adiabatic compression of the residual air. 	<ul style="list-style-type: none"> ● Shown at page I-12 and I-13.
Burning	  Foreign material is embedded in seal and backup ring.	<ul style="list-style-type: none"> ● Existence of foreign material in oil and in pipings. ● Production of metal powder as a result of seizure of piston and cylinder. 	<ul style="list-style-type: none"> ● Make sure to carry out washing. ● Change the material of wear ring and of bearing to the one that can resist against the lateral load.



TECHNICAL DATA

JIS STANDARDS FOR LEAKAGE AMOUNT	I-2
PISTON PACKING LEAKAGE AND WEAR	I-3
ROD PACKING LEAKAGE AND WEAR	I-4
MINIMUM SERVICE PRESSURE	I-5
SLIDING RESISTANCE	I 6-7
LOW TEMPERATURE RESISTANCE PACKINGS	I-8
BUFFER RINGS	I-9
PACKINGS FOR EXTREMELY SHORT STROKES	I 10-11
PHENOMENON OF BURNING	I 12-13
STICK/SLIP	I-14

TECHNICAL DATA

1. JIS STANDARDS FOR LEAKAGE AMOUNT (JIS B 8354)

PISTON PACKING (INTERNAL OIL LEAKAGE)

JIS (JAPAN INDUSTRIAL STANDARDS) states that, when the maximum pressure is applied to one side of an immobilized piston and the amount of oil leakage to the other side of the piston must be less than those listed in the Table 1-1, under the test condition shown in the right. With combined seals (SPG, SPGW), the amount of the internal oil leakage must be less than twice the figures in Table 1-1.

Testing Conditions

Oil used : Hydraulic oil, unless specified otherwise, shall be equivalent to 2 kinds of turbine oil specified by JIS K 2213 with viscosity grade ISO VG32 or VG46.
 Oil temperature : $50 \pm 5^\circ\text{C}$ unless specified otherwise.
 Piston speed : 0

<Table 1-1> Acceptable amount of internal oil leakage for piston packings

Unit : ml/10min

I.D. (mm)	Amount of oil leakage	I.D. (mm)	Amount of oil leakage	I.D. (mm)	Amount of oil leakage
32 (31.5)	0.2	100	2.0	200	7.8
40	0.3	125	2.8	220 (224)	10.0
50	0.5	140	3.0	250	11.0
63	0.8	160	5.0		
80	1.3	180	6.3		

● Acceptable leakage amount for combined seal is double of the listed value.

ROD PACKING (EXTERNAL OIL LEAKAGE)

JIS states "that there should be no leakage, except from the rod, under any operating condition, when piston makes reciprocating motion under the test condition as described below with regard to external oil leakage of hydraulic cylinder." Oil leakage from rod is classified into Type A, Type B and Type C as given in Fig. I-1.

<FIG. I-2> PISTON SPEED

Cylinder tube I.D. (mm)	Piston speed (mm/s)
32 40 50 63	8~400
80 100 125	8~300
140 160 180 200 220 250	8~200

<FIG. I-1> Acceptable external oil leakage

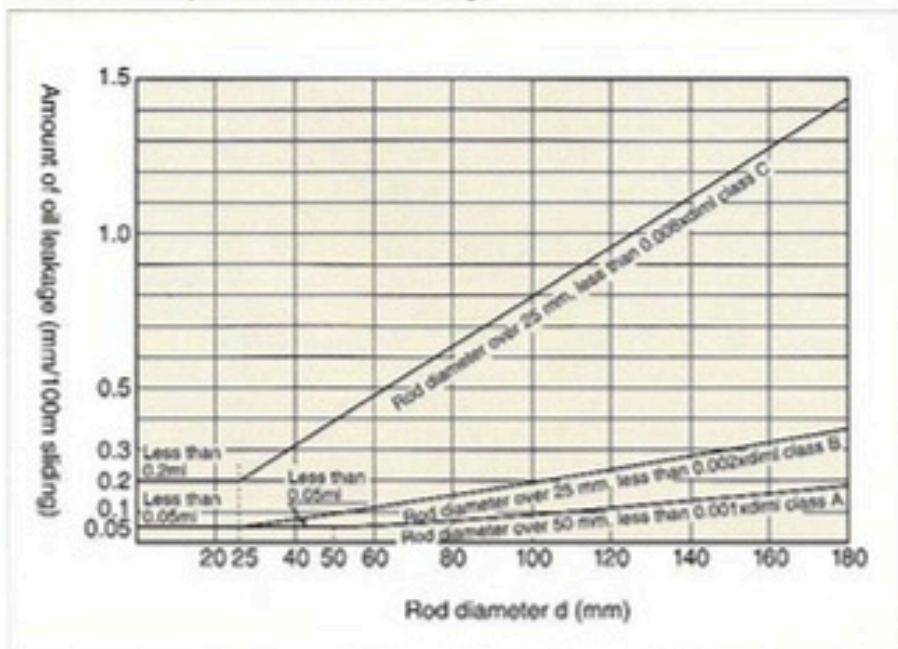

Test conditions

Oil used : 2 kinds of JIS K 2213 (Added turbine oil) hydraulic oil with viscosity ISO VG32 or VG46, unless otherwise specified.
 Temperature of oil : $50 \pm 5^\circ\text{C}$ unless otherwise specified
 Piston speed : To be decided according to the inside diameter of the cylinder tube. (Table 1-2)
 Internal pressure : Internal pressure generated in the cylinder shall not exceed, at any moment during the test, the maximum operating pressure except hydraulic pressure test.

2. AMOUNT OF OIL LEAKAGE AND WEAR OF PISTON PACKINGS

Relationship between internal surface roughness of the cylinder tube and amount of oil leakage

Fig. 1-2 shows the relationship between internal surface roughness of the cylinder tube and the amount of oil leakage for piston packings (SPG, SPGW, OSL, OUHR).

Test conditions

Pressure : 17.7MPa [180kgf/cm²]
(Constant)
Stroke : 100mm
Piston speed : 100mm/s
Oil used for test : Turbine oil grade 2
Temperature of oil : 60~70°C (In the tank)
Tube inside diameter : φ100
Sliding distance : 80km

<Fig. 1-2> Relation between Internal Surface Roughness of Cylinder Tube and Amount of oil leakage when sliding

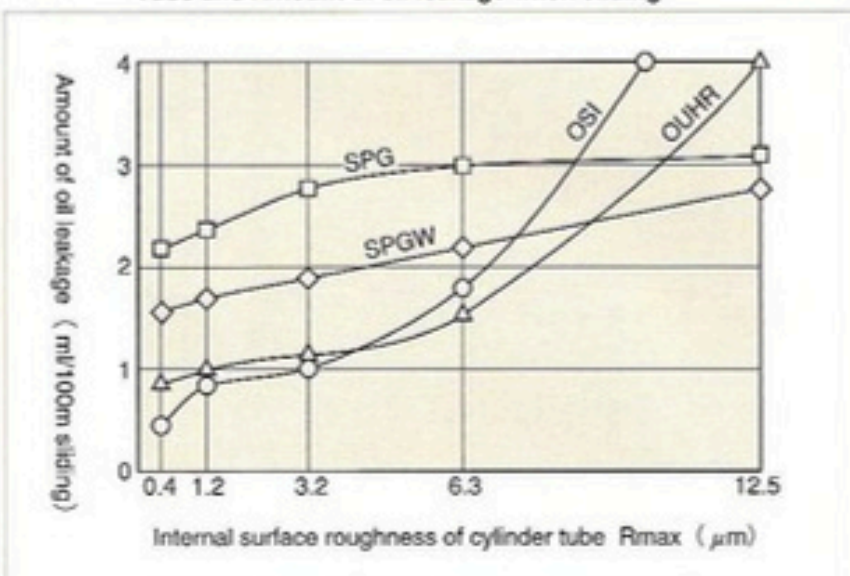

- JIS allows the internal oil leakage at static condition as shown in the Table 1-1, but no internal oil leakage has been found on any packings with this test.

Relationship between internal surface roughness of the cylinder tube and amount of wear

Fig. 1-3 shows the relationship between internal surface roughness of the cylinder tube and the amount of wear for piston packings (SPG, SPGW, OSL, OUHR).

Test conditions

Pressure : 17.7MPa [180kgf/cm²]
(Constant)
Stroke : 100mm
Piston speed : 100mm/s
Oil used for test : Turbine oil grade 2
Temperature of oil : 60~70°C (In the tank)
Tube inside diameter : φ100
Sliding distance : 80km

<Fig. 1-3> Internal surface roughness of cylinder tube and wear amount

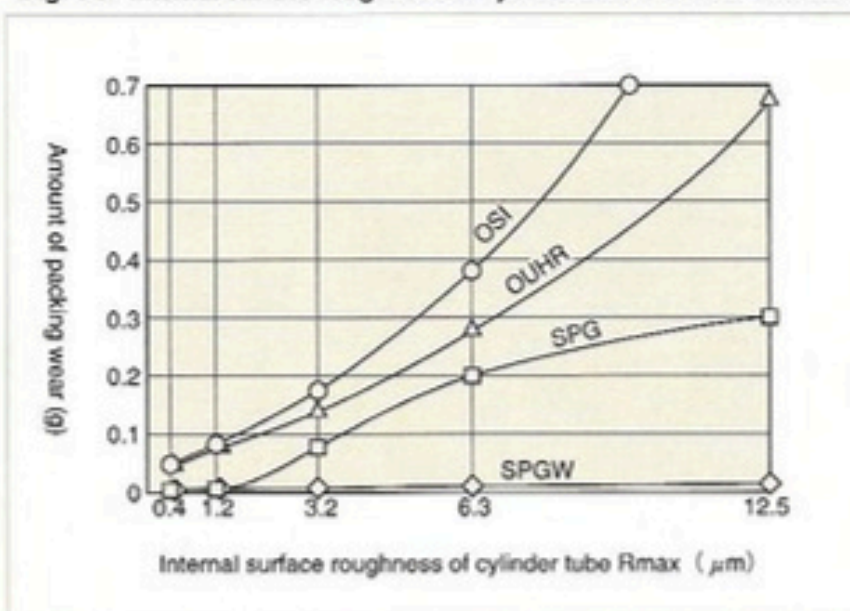

- Packings for high wear resistance such as SPG and SPGW are suitable for use with the types of hydraulic cylinders which can allow some internal oil leakage.
- It is recommended to finish the internal surface of cylinder tube to 0.4 - 3.2 μm R_{max} (0.1 - 0.8 μm R_a).

3.AMOUNT OF OIL LEAKAGE AND WEAR OF ROD PACKINGS

Relationship between rod surface roughness and amount of oil leakage

Fig. 1-4 shows the relationship between rod surface roughness and the amount of oil leakage for U packings (UPH, USI, and IDI).

Test conditions

Pressure	: 0 ~ 13.7MPa (0 ~ 140kgf/cm ²)
Stroke	: 200mm
Rod speed	: 500mm/s
Oil used for test	: Turbine oil grade 2
Temperature of oil	: 100°C
Rod diameter	: φ 50
Sliding distance	: 1000km

<Fig. 1-4> Rod surface roughness and amount of oil leakage

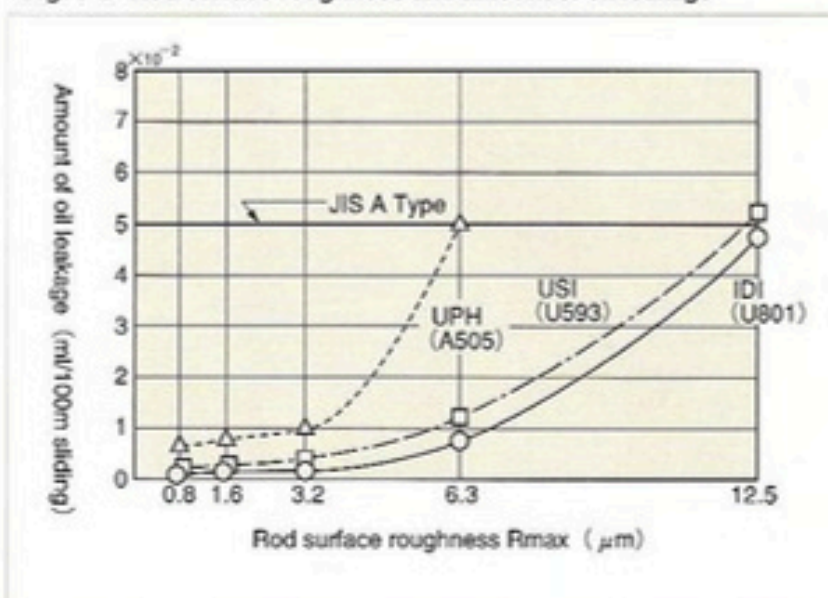

● As the rod surface roughness affects the oil leakage, it is suggested to finish to 0.8 ~ 1.6μm Rmax (0.2 ~ 0.4μm Ra)

Relation between Rod Surface Roughness and Amount of Wear

Fig. 1-5 shows the relationship between rod surface roughness and amount of wear of U packings (UPH, USI and IDI).

Test conditions

Pressure	: 0 ~ 13.7MPa (0 ~ 140kgf/cm ²)
Stroke	: 200mm
Rod speed	: 500mm/s
Oil used for test	: Turbine oil grade 2
Temperature of oil	: 100°C
Rod diameter	: φ 50
Sliding distance	: 1000km

<Fig. 1-5> Rod Surface Roughness and Amount of Wear

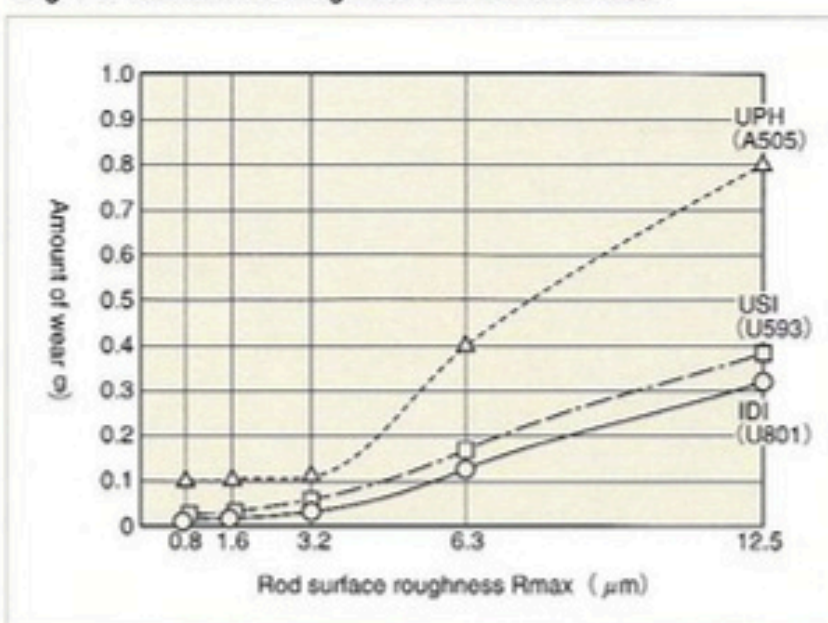

● When the rod surface is too rough, the amount of wear of rod packing will increase. Therefore, it is suggested to finish it to 0.8 ~ 1.6μm Rmax (0.2 ~ 0.4μm Ra)

4. MINIMUM SERVICE PRESSURE

Fig. 1-6 shows an example of actual measurement of the minimum service pressure of piston packings (ODI, UPI, UPH, OUHR and SPG).

Test conditions

Cylinder tube I.D. : $\phi 100$
 Rod diameter : $\phi 70$
 Rod packing : UPH 70 X 90 X 15
 Dust seal : DKB 70 X 84 X 8 X 11
 Pressurizing board : Cylinder head side

Cylinder operating conditions

Pressure : 0 ~ 16.7 MPa
 [0 ~ 170 kgf/cm²]
 Stroke : 650 mm
 Speed : 650 mm/s (Average)
 Oil used : Turbine oil grade 2
 Oil temperature : 80 °C (Maximum)

<Fig. 1-6> Example of actual measurement of the minimum service pressure

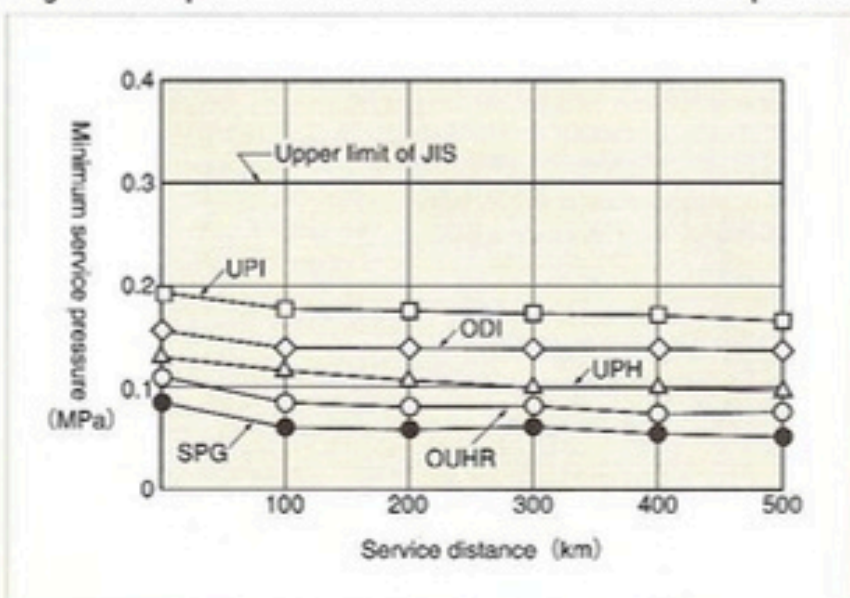

● As NOK Rareflon (NOK's brand name of polytetra-fluoro-ethylene, PTFE) is used for sliding material of SPG packing, and self-lubrication property of OUHR packing is improved, the service pressure for the both shows low values.

WHAT IS MINIMUM SERVICE PRESSURE?

The minimum pressure is required to ensure the operation of the cylinder. When the pressure is applied from the head side (H) or the rod side (R) of the cylinder without any load as shown in the Fig. 1-7, the minimum pressure required to allow a smooth operation of the piston at the minimum speed (8mm/sec) shown in the Table 1-2 is called the minimum service pressure. JAPAN INDUSTRIAL STANDARD JIS B 8354 (Hydraulic cylinder) prescribes this minimum service pressure. Table 1-3 shows the minimum service pressure in the case when the pressure is applied from the cylinder head side. According to JIS, "When the mini-

um service pressure is required lower than specified below, the said value can be modified under an agreement between the parties concerned for delivery".

<Fig. 1-7> Example of cylinder used for measuring the minimum service pressure.

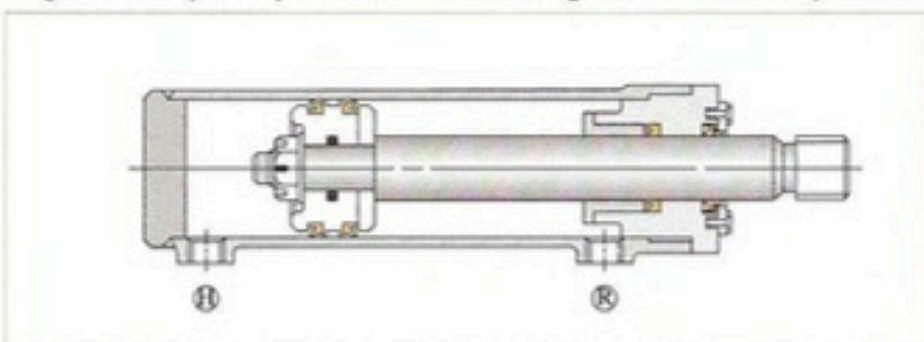

<Table 1-3> Example of JIS Minimum Service Pressure (when the pressure is applied from the cylinder head side).

Unit : MPa

Shape of piston packing	Nominal pressure	Shape of rod packing		Remark
		Other than V packing	V packing	
V packing	3.5 , 7	0.5	0.75	The minimum service pressure when the pressure, is applied from the rod side, is defined by the classification of rod diameter. For detail, kindly refer to JIS B 8354.
	14 , 21	Nominal pressure X 6%	Nominal pressure X 9%	
U.L Packing, X ring, O ring, combination seal	3.5 , 7	0.3	0.45	
	14 , 21	Nominal pressure X 4%	Nominal pressure X 6%	
Piston ring	3.5 , 7	0.1	0.15	
	14 , 21	Nominal pressure X 1.5%	Nominal pressure X 2.5%	

5.SLIDING RESISTANCE

Fig. 1-8 shows an example of actual measurement of sliding resistance of piston packings (SPG, UPH, OUHR).

Test conditions

I.D. of cylinder tube : $\phi 100$
 Piston speed : 300mm/s
 Oil used : Turbine oil grade 2 (ISO VG46)
 Oil temperature : 60°C

Test equipment

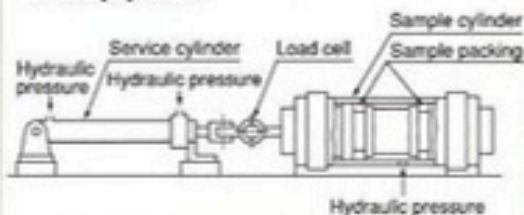

■ Shape of lip edge with U packing that affects frictional resistance and sealing performance.

Frictional resistance and sealing performance vary with the lip shape of U packings as shown in Fig. 1-9 and Fig. 1-10.

	OUHR ($\phi 120$) packing	USH ($\phi 120$) packing
Sample packing		

Measuring conditions of sliding resistance

Temperature : 80°C constant
 Pressure : 0, 2, 3.4, 4.9, 6.4MPa
 [0, 20, 35, 50, 65kgf/cm²]
 Speed : 75mm/s
 Stroke : 20mm
 Oil used : Turbine oil grade 2 (ISO VG46)

Impulse endurance test conditions

Temperature : 100°C
 Pressure : 0~24.5~36.8MPa
 [0~250~375kgf/cm²]
 Frequency of pressurization : 70c.p.m
 Number of pressurization : 600,000 times
 Speed : 150mm/s
 Stroke : 150mm
 Oil used : Turbine oil grade 2 (ISO VG46)

● Recommend to use OUHR packing with improved self-lubrication property as the piston U packing for low friction.

<Fig. 1-8> Frictional resistance and Pressure

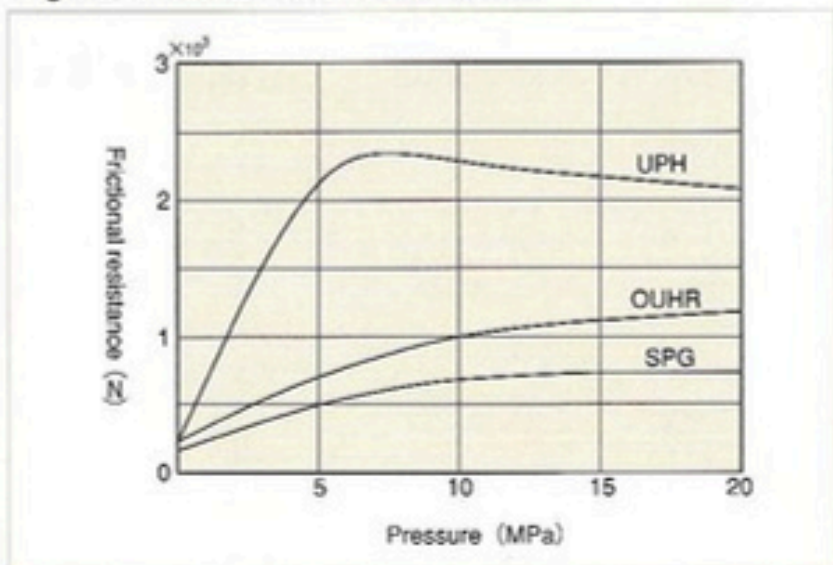

● Use SPG or SPGW for piston packing for low friction.

<Fig. 1-9> Frictional resistance and pressure

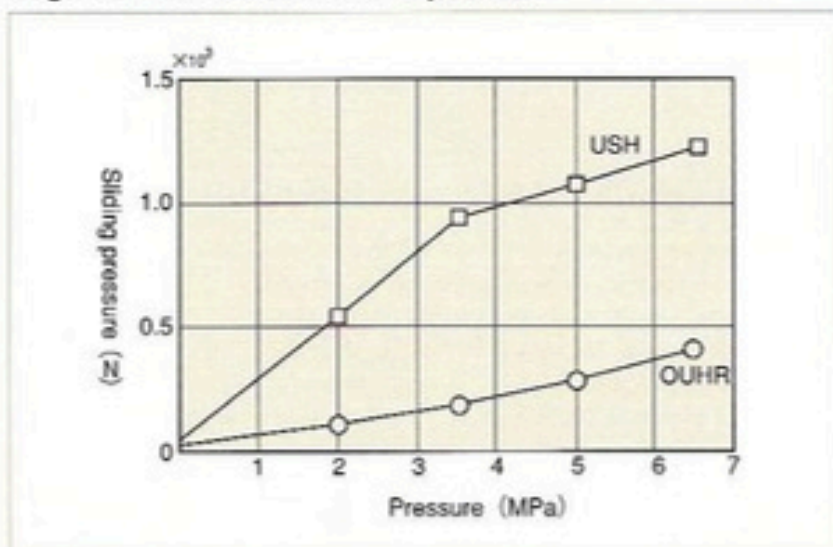

<Fig. 1-10> Number of pressurization and amount of oil leakage

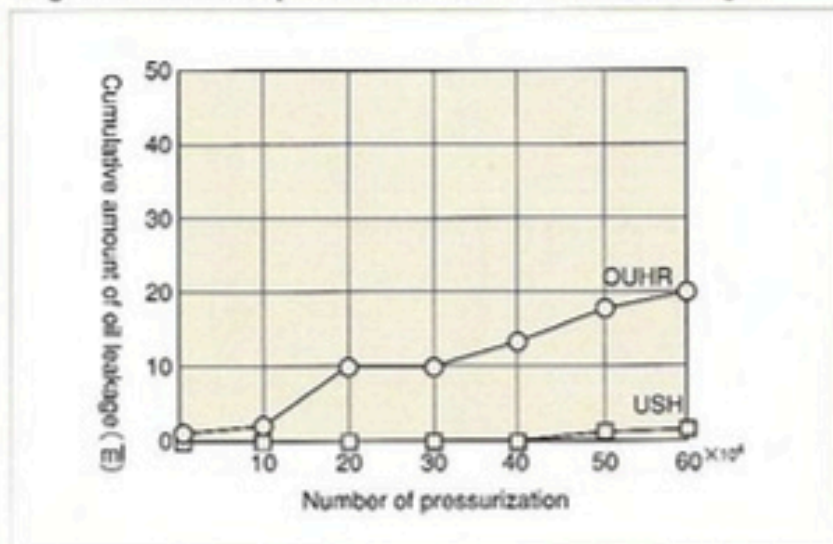

HOW TO CALCULATE FRICTIONAL RESISTANCE OF PACKINGS

Frictional resistance can be calculated from the following formula.

$$F = f \times Pr \quad \dots\dots\dots (5)$$

Where,

- F : Frictional resistance (N)
- f : Frictional coefficient
- Pr : Packing radial force (N)

Therefore, in order to find the frictional resistance, it is necessary to know the values of frictional coefficient and packing radial force. To obtain the friction coefficient *f*, use the non-dimensional characteristic diagram in Fig. 1-11, *G* in accordance with operating condition and read the value *f*.

Use Formula (6) to find out the radial force of a packing when pressure is applied.

$$Pr = \pi dbp + Pro \quad \dots\dots\dots (6)$$

Where,

- d : Rod diameter (cm)
- b : Contact width (cm)
- p : Applied pressure (Pa)
- Pro : Radial force of packing under ambient pressure (N)

The value *Pro* varies with the shape and material of packings. Fig. 1-12 shows, for your reference, an example of actual measurement of radial force of representative packings. As the applied pressure becomes higher, *Pro* becomes a negligible value in function to πdbp in the formula (6).

<Fig. 1-11> Dimensionless characteristic diagram

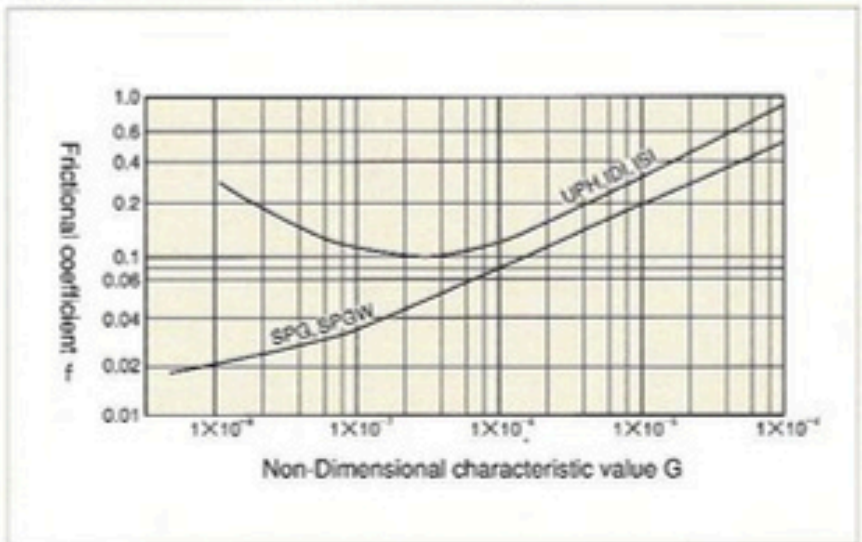

● Please refer to Page A-6 for calculating method of the dimensionless characteristic number *G*.

<Fig. 1-12> Radial force of packing (Under ambient pressure)

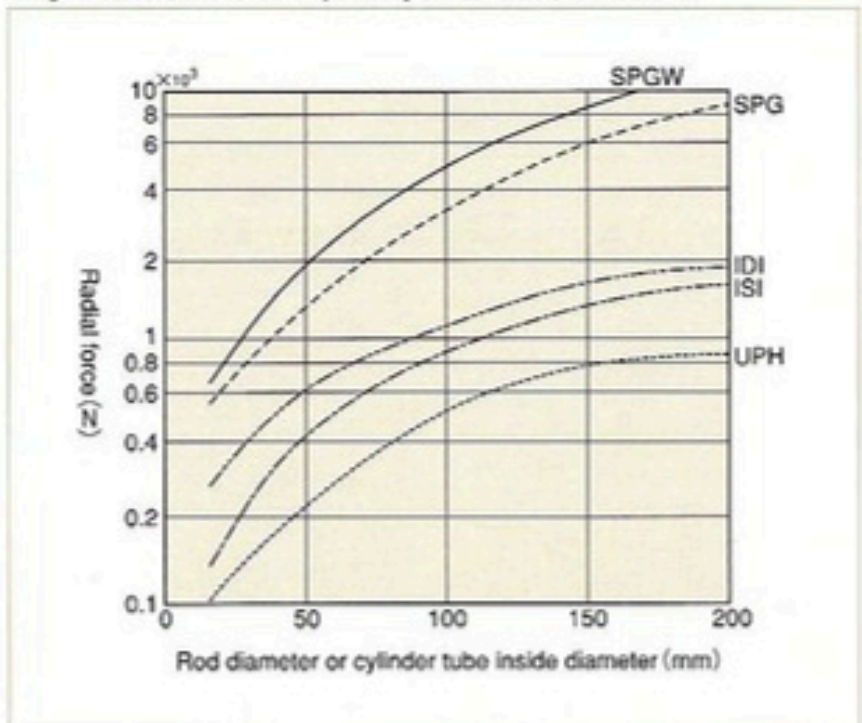

6. LOW TEMPERATURE RESISTANCE PACKINGS

The standard rubber material for NOK packings (material code A505, U801) aims at about -30°C as limit temperature for low temperature usage. In low temperature areas, the rubber packing material's elasticity decreases and its sealing performance becomes unstable. As the packing lip's ability to follow the eccentricity of the rod decreases, it becomes important to reduce the amount of eccentricity of the rod. When using packings in a low temperature area, minimize rod eccentricity, and apply a low temperature resistance packing.

Test conditions

Sample : U packing for rod diameter ϕ 75
(Dipped in oil at 100°C for 70H prior to the test)
Pressure : 2MPa [20kgf/cm²] (constant pressure)
Stroke : 20mm
Cycle : 1c.p.s
Oil used for test : Hydraulic oil for extra low temperature
Test duration : After leaving the test piece for 15 hours at each temperature, stroke for 15 minutes.

EFFECT OF ECCENTRICITY ON SEALING PERFORMANCE AT A LOW TEMPERATURE

Table 1-4 and Table 1-5 show an example of test results with low temperature resistant U packings and standard U packings.

As the eccentricity affects sealing performance at low temperature, use H9f8 fit for bush or bearing.

<Table 1-4> Cold resistant U packings

Sample packing	IUH 75 85 6 (A903) Low temperature resistant nitrile rubber					UNI 75 88 10 (①U801) (②S813)				
	-40	-45	-50	-55	-60	-40	-45	-50	-55	-60
Amount of eccentricity (TIR)										
0.15mm	○	○	○	○	△	○	○	○	○	△
0.30mm	○	○	○	○	△	○	○	△	△	●
0.45mm	○	○	△	△	●	△	△	△	●	●

<Table 1-5> Standard U packings

Sample packing	IUH 75 85 6 (A505)			ISI 75 85 6 (U801)	
	-15	-20	-25	-30	-35
Amount of eccentricity (TIR)					
0.15mm	○	○	○	○	△
0.30mm	○	○	○	○	△
0.45mm	○	○	△	△	●

○---No oil leakage △---Oil leakage while sliding ●---Oil leakage at static

EFFECT OF LOW TEMPERATURE HYDRAULIC OIL FOR INITIAL FRICTIONAL RESISTANCE

Some low temperature hydraulic oil increase the frictional resistance of packings. This is caused by remaining dried additives in oil. Fig. 1-13 shows an example of measuring the initial frictional resistance with low temperature oil.



<Fig. 1-13> Result of measurement of initial frictional resistance

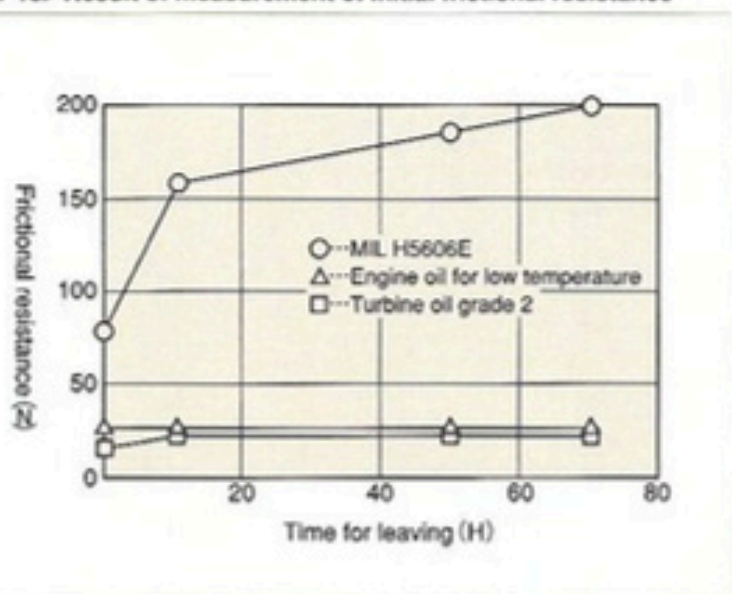

Test conditions

Temperature : 25°C
Pressure : Ambient pressure
Speed : 250mm/s
Stroke : 50mm
Oil used : ① MIL H 5606E
② Engine oil for low temperature
③ Turbine oil grade 2 (ISO VG32)

Time for leaving sample : 0, 12, 48, 72 (H)

Leaving conditions

By making rod to perform several stroke, let the oil film deposited on the rod surface and leave the packing as it is at room temperature.

7. BUFFER RINGS

Buffer rings (HBY and HBTS) are inserted in the pressure side of rod packings to protect and improve packing durability. Also, under extremely short stroke conditions, they help prevent abnormal wear of rod packings.

EXAMPLE OF BUFFERING EFFECT ON IMPACT PRESSURE

Test conditions	Construction (rod sealing system)	Conditions after test
Rod diameter : $\phi 70$ Pressure : $0 \sim 41.2 \text{ MPa}$ $[0 \sim 420 \text{ kgf/cm}^2]$ Speed : 530 mm/s Stroke : 900 mm Oil used : Turbine oil grade 2 (ISO VG46) Oil temperature : $90 \pm 5^\circ \text{C}$ (in the tank) Sliding distance : 250 km	With a buffer ring 	 HBY: Fine wear IUH: No wear BRT2: Extrusion
		 HBTS: Fine extrusion IUH: No wear BRT2: No extrusion
	Without a buffer ring 	 IUH: Wear BRT2: Extrusion

3 effects of buffer rings

- (1) To buffer the impact pressure generated on the rod side of a hydraulic cylinder.
- (2) To inhibit transmission of oil temperature to rod packings.
- (3) To reduce frictional resistance and generation of sliding heat of rod packings.

Buffer ring does not generate accumulated pressure between rod packings, because of back pressure relief property.

EXAMPLE OF REDUCTION OF TEMPERATURE AT SLIDING AREA

<Fig. 1-14> An example of measurement of temperature at sliding area
(For test conditions and temperature at (A), refer to the test condition.)

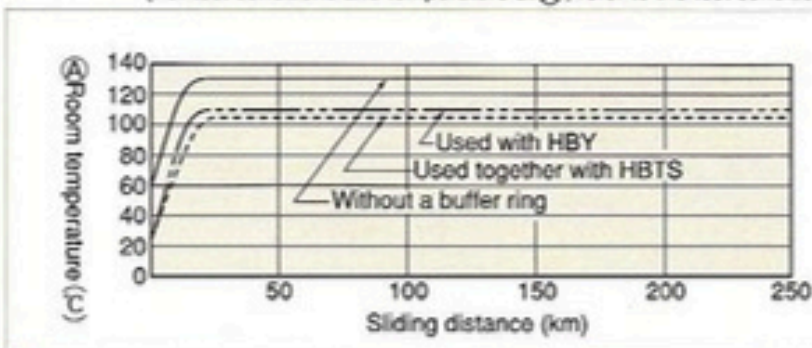

- When the impact pressure and the oil temperature are high, reduction of pressure and temperature of sliding part can be obtained by using a buffer ring.
- It is recommended to use packing and buffer ring together.

EXAMPLE OF REDUCTION OF FRICTIONAL RESISTANCE

<Fig. 1-15> Relation between hydraulic pressure and frictional resistance

Construction (Rod sealing system)



Test conditions

Pressure : $0 \sim 9.8 \text{ MPa}$
 $[0 \sim 100 \text{ kgf/cm}^2]$
 Speed : 30 mm/s
 Stroke : 100 mm
 Oil used : General purpose hydraulic oil
 Temperature : Constant temperature at 80°C

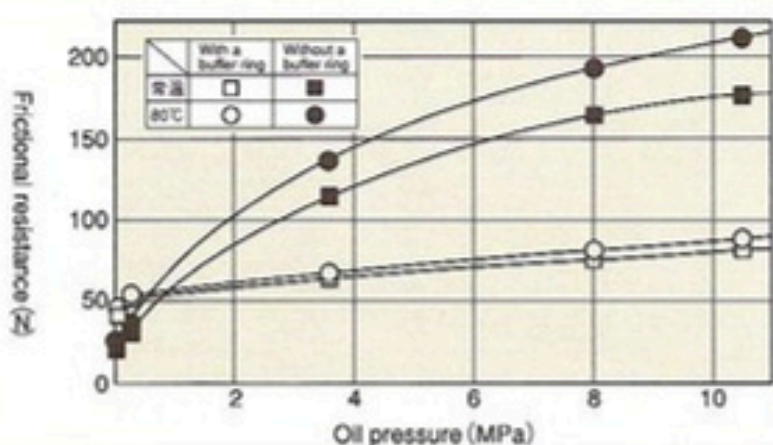

8.PACKINGS FOR EXTREMELY SHORT STROKE

When packings are used with extremely short strokes, breaking of oil film (out of lubricant) occurs, and abnormal wear of the packing may occur. To prevent this, the packing must be designed to allow an easy formation of the lubricant film and to use material with better wear resistance.

"The term of the extremely short stroke" is defined as strokes becomes less than the minimum stroke of 25mm which is specified in JIS B8354.

PISTON PACKINGS

Test method

In order to investigate the internal oil leakage amount, the test was conducted with the test condition below. The oil leakage was measured at 250,000, 500,000, 750,000 and 1,000,000 cycles of the test. The oil leakage was collected from the port (H) at the head side, while applying oil pressure 34.3MPa [350kgf/cm²], for ten minutes to the port (R) at the rod side.

Test equipment

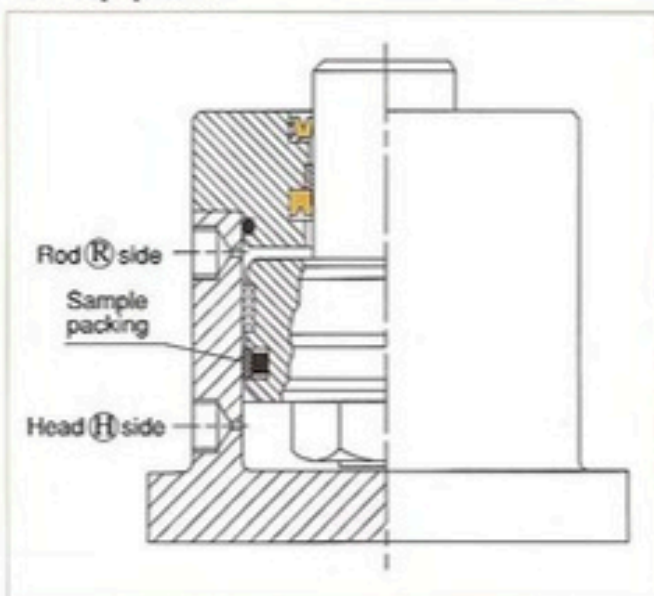

Sample packing

Cross section of seal	Type and size	Material
	SPG 94 110 7.3	①19YF ②A980
	OSI 110 95 9	U801
	OUHR 110 95 9 BRT2 95 110 3	①A903 ②19YF

Test condition

Oil used : General purpose hydraulic oil
 Pressure : Rod (R) side
 0~34.3MPa [0~350kgf/cm²]
 Head (H) side
 0~2MPa [0~20kgf/cm²]
 Stroke : 2mm
 Cycle : 16c.p.m (Average speed 4mm/s)
 Sliding cycle : 100 × 10⁴ times
 Temperature : 95 ± 5 °C (at cylinder internal surface)
 Roughness of cylinder internal surface : 3.2 μm Rmax







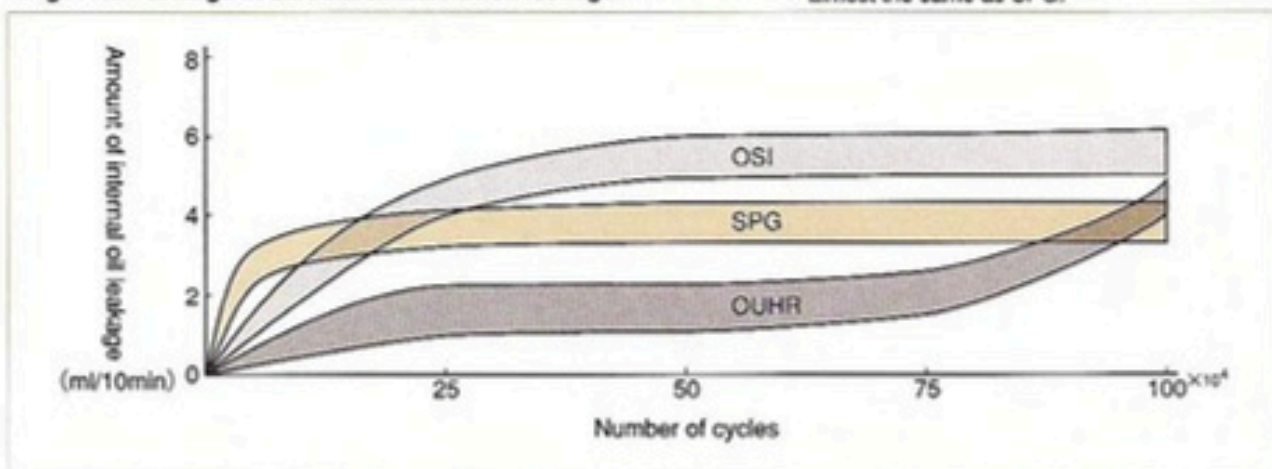





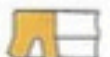

Test results

<Fig. 1-16> Change in amount of internal oil leakage

※ The amount of internal oil leakage for SPGW is almost the same as SPG.



<Fig. 1-17> Sliding surface condition after test









Type & size	Direction of photo	Surface condition	Remarks
SPG 94 110 7.3	 Head side  Rod side		No abnormalities are observed on the sliding face.
OSI 110 95 9	 Head side 		Wear and "sliding trace" are observed on the sliding face.
	 Rod side 		
OUHR 110 95 9	 Head side 		Wear and "heavy sliding trace" are observed on the sliding face.
	 Rod side 		

- For extremely short stroke, it is recommended to use combination seal (SPG or SPGW), using NOK Rareflon (NOK's brand name of polytetra-fluoro-ethylene, PTFE) as the sliding material.

ROD PACKINGS

Fig. 1-18 shows the condition of sliding surface after the extremely short stroke test.

<Fig. 1-18> Condition of sliding surface after test

Type & size (Material)	Direction of photo	Surface condition	
		When buffer ring is used together.	When buffer ring is not used together.
IUH 75 85 6 (A505)	 		
HBTS 75 90.5 5.9 (19YF_A626)	 		

- It is recommended to use the buffer ring (HBTS or HBY) as a part of the sealing system along with the packings, when extremely short stroke condition is expected.
Abnormal wear of rod packing may occur due to breakage of oil film without the buffer ring.

9. PHENOMENON OF BURNING

In some cases, piston packings or wear rings are burned and carbonized or melted. This is due to the high temperature resulting from sudden compression when air inside the hydraulic cylinder has not been completely exhausted.

For example, when a U packing is used as a piston packing, air tends to be accumulated in the pocket part of the U packing. When this air is not replaced by oil at starting movement, the air will be compressed quickly, resulting in high heat generation, at the U packing's pocket.

By this, the packing is partially burned and carbonized. With some material, it may actually melt.

When a rod is directed upward, air is accumulated at the pocket part of U packing A on the head side, and "damage by burning" can be seen in Fig. 1-20. Also, the wear ring may be burnt, as shown in Fig 1-21.

The phenomenon of burning tends to occur when starting a hydraulic cylinder, but seldom occurs during operation.

The heat generation due to adiabatic compression may reach 600 to 800 °C for a short period of time and instantaneously exceeds the heat resistant limit of packing material.

<Fig. 1-19> Example of damage by burning of U packing

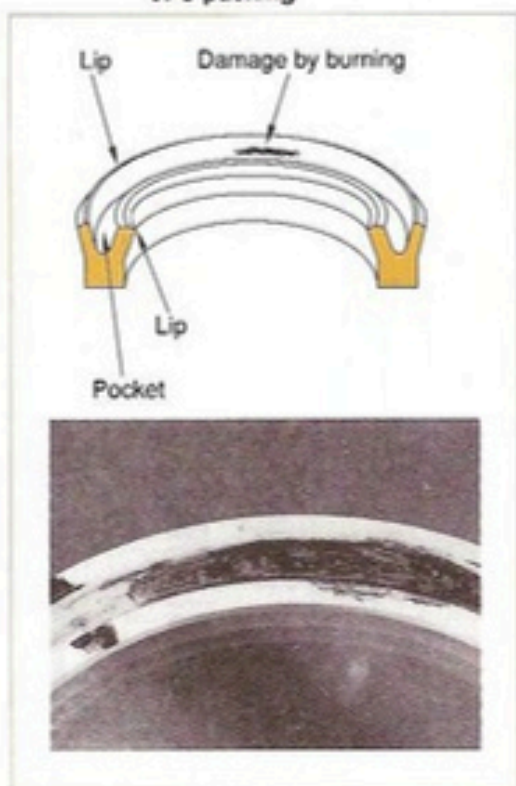

<Fig. 1-20> Example of locations of damage by burning

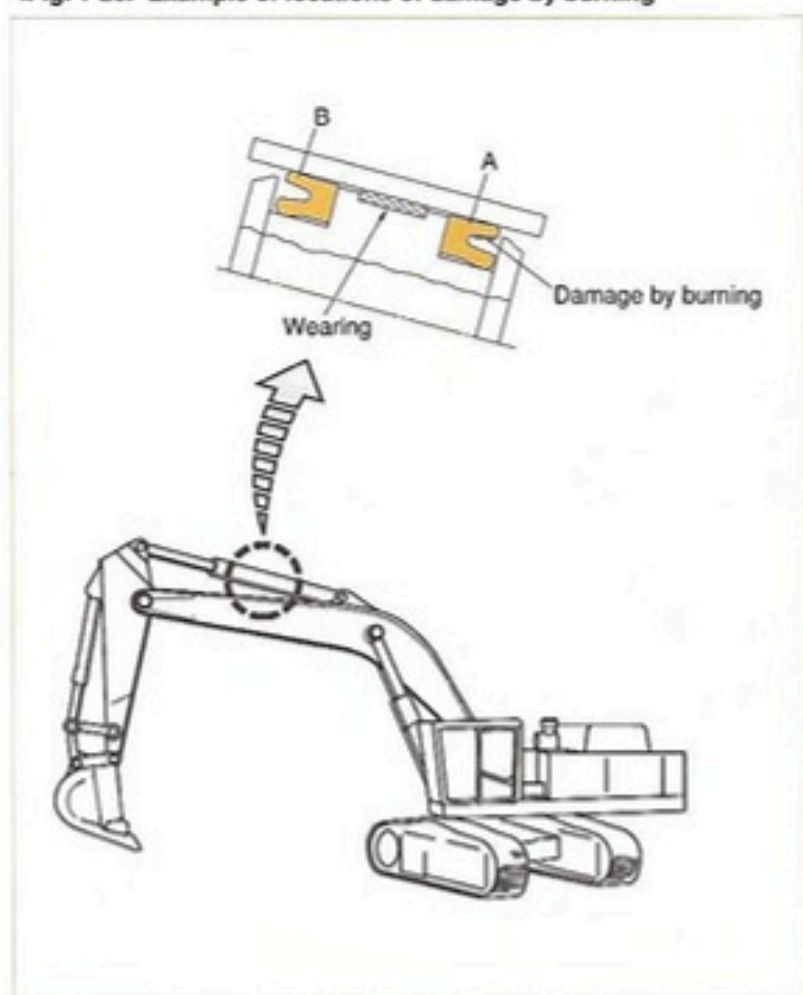

<Fig. 1-21> Example of damage by burning of wearing

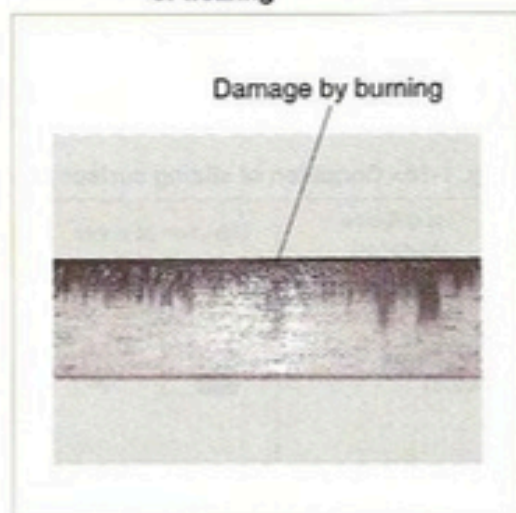

FORMULA FOR CALCULATING RISE OF TEMPERATURE BY ADIABATIC COMPRESSION

Although, in the case of an actual hydraulic cylinder, it cannot be said to be a perfect adiabatic compression due to the existence of heat conduction and dispersion, etc. from the rod surface or tube wall face, the rise of temperature can be calculated from the formula (7).

$$T_2 = T_1 \times \frac{P_2 \cdot V_2}{P_1 \cdot V_1} = T_1 \left(\frac{P_2}{P_1} \right)^{\frac{\kappa-1}{\kappa}} \quad \dots\dots\dots (7)$$

- T₁ : Absolute temperature before compression (°K)
- T₂ : Absolute temperature after compression (°K)
- P₁ : Pressure before compression (MPa)
- P₂ : Pressure after compression (MPa)
- V₁ : Volume of air before compression (cm³)
- V₂ : Volume of air after compression (cm³)
- κ : Adiabatic index (In case of air, κ = 1.4)

Now, let's calculate the heat generation by adiabatic compression by using this formula. Suppose the pressure in the hydraulic cylinder varies between 1 and 42MPa. For example, suppose the oil temperature is 80 °C when the pressure is 1MPa, then the absolute temperature T₂ by the adiabatic compression is

$$T_2 = (273 + 80) \times \left(\frac{42}{1} \right)^{\frac{1.4-1}{1.4}} \approx 1027 \text{ (°K)}$$

This temperature is equivalent to 754 °C. The value neglects the adiabatic efficiency and other loss in its calculation. Even if this were taken into consideration, the packing is instantaneously exposed to a high temperature.

PREVENTION OF DAMAGE BY BURNING

Remark the following points to prevent the damage of burning due to such adiabatic compression.

- (1) Bleed air from the hydraulic cylinder sufficiently before starting the hydraulic cylinder.
- (2) When starting the hydraulic cylinder, do not operate it quickly to its full stroke.
- (3) When using U packings, fill the pocket with grease to minimize the accumulation of air.
- (4) Design the construction of piston as shown in the Fig.1-22 and use Rareflon (NOK's brand name of 4 ethylene fluoride resin) seal (Type KZT, contamination seal) having a good heat resistance at the outside of the wearing (WR).

<Fig. 1-22> Example of countermeasure against damage by burning

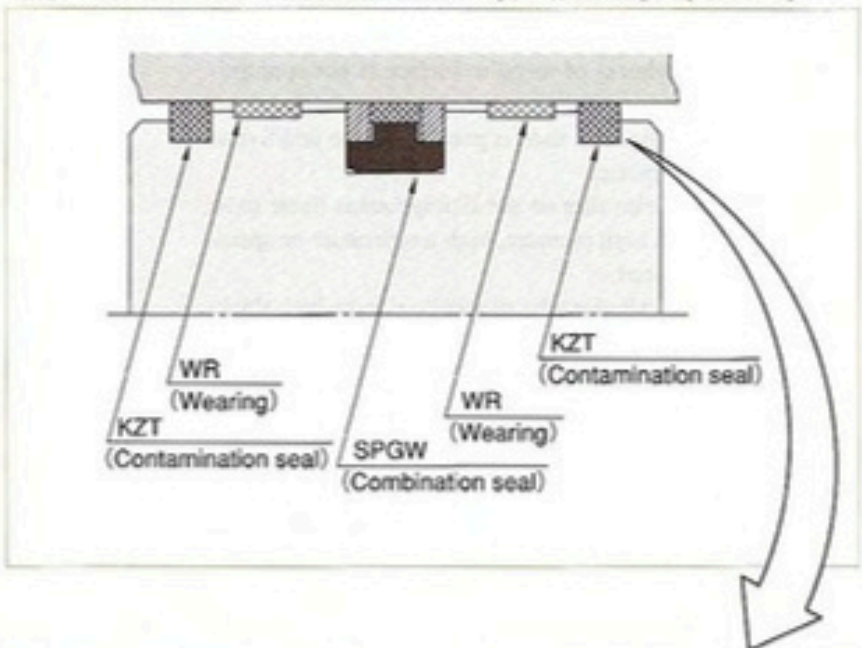

● Fig. 1-22 shows the most effective piston sealing system as a countermeasure against the damage by burning.

We recommend to use KZT (Contamination seal) to prevent entry of foreign materials in the oil and to prevent the damage by burning.

10. STICK-SLIP

Stick-slip is a phenomenon that a sliding surface has sticking and slipping condition periodically. In the case of packings, the stick-slip occurs at a contact face between a packing, an elastic body, and metal mating face, sometimes resulting in vibration and generating sound.

The stick-slip phenomenon in hydraulic cylinders is caused by complex factors including types of bearings, types of packings, fixing method of cylinder, amount of load, etc. Also, the sound generated by stick-slip varies from low to high frequency tones.

■ CONDITIONS CAUSE THE PHENOMENON

Vibrations and sound generation due to the stick-slip of a hydraulic cylinder have not been quantitatively clarified yet. It is qualitatively known, however, that they occur under the following conditions.

- (1) When a static friction coefficient of a packing or bearing material is high.
- (2) When the roughness of metallic surface is not appropriate.
- (3) When the quality of oil used is poor (when the additive to oil is not appropriate).
- (4) When the lubricant film on the sliding face is liable to be broken due to a high pressure, high temperature or operation in a low speed.
- (5) When using a cylinder tube or a hollow rod which thickness is extremely thin or when using a hydraulic hose with a low rigidity.

■ COUNTERMEASURES

As previously mentioned, it is not possible to make perfect countermeasures for stick-slip solely by a packing itself. However, use of a combination seal (SPG or SPGW) made from low-friction material such as Rareflon (NOK's brand name of PTFE) or use of the U packing (OUHR) improved self lubrication.

Also, additional use of a buffer ring with good lubricating characteristic (HBTS) as shown in Fig. 1-23(a) and/or filling grease between a rod packing and a dust seal will be effective in preventing oil film breakage, due to high pressure.

<Fig. 1-23> Example of countermeasure against stick-slip

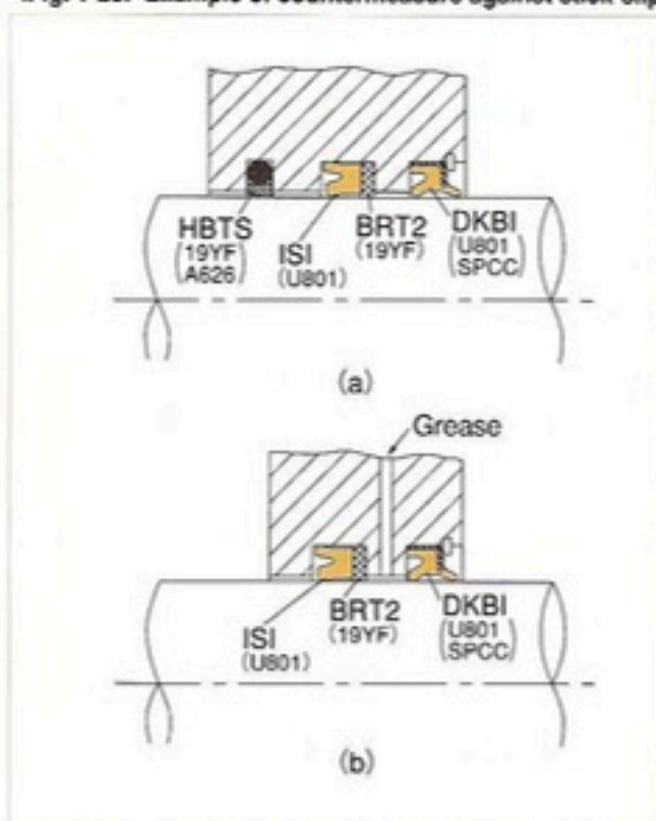



DATA FOR REFERENCE

OIL RESISTANCE AND CHEMICAL RESISTANCE OF NOK MATERIALS	J 2-11
FITTING TOLERANCE FOR SHAFT	J-12
FITTING TOLERANCE FOR BORE	J-13
STANDARD FITTING TOLERANCE FOR LARGE DIAMETER	J-14
TABLE OF MAJOR SI UNIT CONVERSION	J-14
TABLE OF HARDNESS CONVERSION	J-15
RANGE OF ROUGHNESS BY VARIOUS METHODS OF PROCESSING	J-15
TABLE OF ROUGHNESS CONVERSION	J-15
TABLE OF VISCOSITY CONVERSION	J-16
TABLE OF TEMPERATURE CONVERSION	J-17
NOK KLUEBER LUBRICANT FOR SEALS	J-18
LINE-UP OF NOK PRODUCTS	J 20-21

J .DATA FOR REFERENCE

OIL RESISTANCE AND CHEMICAL RESISTANCE OF NOK MATERIAL

This data is a summary of all the experimental data related to the materials and it gives a reference of material compatibility to each brand of oil or chemical. When selecting material, kindly check, referring to this collection of data, whether the material in question is compatible to the brand of oil or chemical which you are going to use. Please note, however, that they are representative values of actual measurement and not of guarantee.

This data includes nonstandard materials for each type of packing, due to the fact that the selection of material has been carried out in consideration of the sealing liquid in question.

When using materials other than standard, please consult with NOK.

[HOW TO READ THE TABLES]

The test method is in compliance with JIS K6301 "Physical Test Method for Sulfate Rubber (Dipping Test Method)". The table shows the test temperature, time and change in hardness, tensile strength, volume after test, and compatibility.

+ symbol before figure means the increase to the value of before test, while - symbol means the decrease to the one of before test. In any case, if the absolute values of these figures are smaller, the better are oil and chemical resistances.

Compatibility is the result from judgement supposing the case where the product has been continuously operated

for 500 hours at the temperature specified in the Table. If data exceeding 500 hours are available, compatibility for the said duration is also mentioned. Symbols used in the column of compatibility are as follows:

- : Resistant
- : Resistant except special cases*
- △ : Not resistant except special cases*
- × : Not resistant

In most cases, judgement is made based upon the data of change in hardness and volume. In some cases, however, the judgements show △ or × in spite of the small value with hardness and volume. The "compatibility" is judged by taking other factors into account, so they are not contradictory to the principle mentioned above. The compatibility of NOXLAN is judged mainly by change in tensile strength.

On the other hand, the test conditions applicable to these data are defined to examine the compatibility of each rubber material with the sealing liquid and not to guarantee the life of the liquid in question. For nature of the liquid, refer to the handbook for brands of lubricants.

*: When using this, please consult with NOK

OIL RESISTANCE DATA

NOK's material symbol A: Nitrile rubber F: Fluoro rubber G: Hydrogenated-nitrile rubber U: Noxlan (Polyurethane)
(-: No data available)

Brand name of sealing liquid (Manufacturer)	NOK's material symbol	Test temperature (°C)	Duration of test (H)	Change in hardness (points)	Change in tensile strength (%)	Change in volume (%)	Adapt able or not
Diesel engine oil	A105	80	70	- 5	-17	+ 4.6	○
			240	- 5	-13	+ 5.4	
		120	70	- 4	-25	+ 3.5	△
			240	- 2	-45	+ 2.9	
	A305	80	70	- 5	-14	+ 4.0	○
			240	- 6	-16	+ 5.2	
		120	70	- 5	-27	+ 4.0	△
			240	- 2	-44	+ 3.2	
	A505	80	70	- 4	- 6	+ 3.3	○
			240	- 3	- 2	+ 4.0	
		120	70	- 3	-15	+ 3.4	△
			240	- 1	-28	+ 3.3	
	A980	80	70	- 9	-10	+ 7.9	○
			240	- 8	-16	+ 7.7	
	120	70	- 8	-34	+ 9.0	△	
		240	- 6	-58	+ 9.0		
U593	100	500	- 2	-33	+ 5.5	○	
U641	100	500	0	- 8	+ 5.2	○	
U801	100	500	- 1	-18	+ 4.8	○	

OIL RESISTANCE DATA

Brand name of sealing fluid (Manufacturer)		NOK's material code	Test temperature (°C)	Duration of test (H)	Change in hardness (points)	Change in tensile strength (%)	Change in volume (%)	compatibility
Diesel engine oil	DELPAK 1210 (MOBIL)	U801	120	500	+ 1	-44	+ 0.3	○
	MOBIL PEGASUS 10W (MOBIL)	U641	100	1000	- 1	-24	+ 3.7	○
		U801	100	500	- 2	-17	+ 1.3	○
	WHITE PARROT SUPER S-3 OIL 10W (SHOWA-SHELL)	A105	1000	0	-73	+ 0.9	×	
			70	0	-23	- 0.9		
			240	+ 1	-35	- 1.5	△	
			500	+ 2	-48	- 1.8	△	
		A305	1000	+ 5	-73	- 2.6	×	
			70	- 3	-16	- 0.1		
			240	- 2	-38	- 0.9		
			500	0	-49	- 1.4	△	
		A505	1000	+ 4	-76	- 1.9	×	
			80	70	- 4	-12	+ 2.3	
			240	- 4	0	+ 2.2		
			500	- 3	- 1	+ 2.3	○	
	1000		- 2	- 5	+ 2.5	○		
	100		70	- 3	- 3	+ 2.2		
			240	- 1	-16	+ 1.4		
			500	0	-27	+ 1.1	○	
		1000	+ 2	-41	+ 1.1	△		
120	70	+ 1	- 8	- 0.1				
	240	+ 1	- 7	- 0.3				
	500	+ 2	-33	- 0.4	△			
	1000	+ 5	-67	- 0.9	×			
A980	120	100	- 4	- 1	+ 4.0			
	240	- 1	-36	+ 4.0				
	500	+ 1	-51	+ 3.6	×			
	1000	+ 4	-79	+ 3.1	×			
U641	120	500	+ 1	-41	+ 2.3	○		
U801	120	500	0	-45	+ 0.4	○		
Gear oil	APPOLLOIL GEAR-MISSION 80W-90 (IDEMITSU)	F201	100	70	- 1	- 4	+ 1.0	○
			120	70	0	-25	+ 1.2	○
			150	70	+ 5	-38	+ 1.7	△
		F480	100	70	- 1	- 6	+ 0.6	○
			120	70	0	-15	+ 0.7	○
			150	70	+ 1	-40	+ 1.0	△
	APPOLLOIL GEAR LSD 80W-90 (IDEMITSU)	F201	100	70	- 1	- 1	+ 0.8	○
			120	70	0	-20	+ 1.1	○
			150	70	+ 4	-30	+ 1.7	○
		F480	100	70	- 1	- 8	+ 0.5	○
			120	70	0	-22	+ 0.8	○
			150	70	+ 1	-35	+ 0.9	△
	GEARLUB SP90 (NISSEKI)	U652	100	336	0	-33	+ 1.5	○
		U801	70	1000	- 1	+ 4	+ 1.3	○
			100	200	0	-49	+ 1.7	×
	GELCO-OIL 6140 (SHOWA-SHELL)	F204	120	70	0	+ 4	+ 0.2	○
	GELCO-OIL No 1 [GL-3] (SHOWA-SHELL)	F204	120	70	0	-12	+ 0.6	○
	NISSAN GEAR OIL MP-G SPECIAL (NISSAN MOTOR GENUINE OIL)	F201	100	70	- 3	-16	+ 2.0	○
			120	70	- 3	-43	+ 3.5	○
			150	70	0	-45	+ 4.2	△
F357		100	70	- 1	- 5	+ 2.0	○	
		120	70	- 1	-40	+ 3.6	○	
		150	70	- 1	-36	+ 4.5	△	
F480		100	70	- 2	-13	+ 1.3	○	
		120	70	- 2	-34	+ 2.2	○	
		150	70	- 2	-38	+ 2.7	△	
NISSAN GEAR OIL HYPOID SUPER 80W-90 (NISSAN MOTOR GENUINE OIL)	G506	120	70	- 1	- 4	+ 2.7	○	
ATF	DEXIRON II (SHOWA-SHELL)	A505	100	70	- 3	+ 5	+ 2.2	○
		A903	100	70	0	+ 3	- 0.8	○
	PAN ATF AMENITI (NISSEKI)	F357	120	70	- 1	- 1	+ 0.5	
240	- 1		- 5	+ 1.0				
500	- 1		- 8	+ 1.2	○			

OIL RESISTANCE DATA

Brand name of sealing fluid (Manufacturer)		NOK's material code	Test temperature (°C)	Duration of test (H)	Change in hardness (points)	Change in tensile strength (%)	Change in volume (%)	compatibility	
A T F	PAN ATF AMENITI (NISSEKI)	F357	150	70	-1	-20	+1.2	○	
				240	-1	-34	+1.7		
				500	-1	-53	+1.8		
		F480	120	70	-1	-4	+0.6	○	
				240	-1	-7	+0.7		
				500	-1	-21	+0.8		
			150	70	-1	-20	+0.8	○	
				240	-1	-40	+1.0		
				500	-1	-53	+1.2		
	MOBIL ATF220 (MOBILE)	A104	100	70	-3	-4	+1.0	○	
				168	-3	-6	+0.8		
		A105	100	70	-4	-8	+3.0	○	
				168	-3	-10	+2.3		
		A305	100	70	-7	-3	+4.2	○	
				168	-5	-9	+3.4		
		A980	100	70	-5	+4	+5.1	○	
168				-5	+6	+5.0			
CASTLE AUTOFLUID SPECIAL W (TOYOTA MOTORS GENUINE OIL)	A505	100	70	-6	+7	+5.2	○		
			168	-5	+8	+4.2			
	A903	80	70	0	+10	-1.6	○		
			168	+1	+10	-2.3			
		100	70	+3	+4	-1.5	○		
			168	-6	+7	+5.3			
CASTLE HYDRAULIC OIL 32 (TOYOTA MOTOR GENUINE OIL)	A505	100	70	-2	+7	+0.4	○		
			168	0	+10	-0.3			
	A903	80	70	0	+10	-1.6	○		
			168	+1	+10	+2.3			
	U801	100	336	0	+6	0	○		
Brake oil	TOYOTA GENUINE BRAKE FLUID 2500H (TOYOTA)	F357	150	70	-28	-76	+44.6	×	
				168	-32	-85	+45.9		
G506		150	70	-13	-16	+24.4	△		
			168	-13	-19	+24.3			
Hydraulic oil	DAFFNEY HYDRAULIC FLUID 32 (IDEMITSU)	A795	100	200	+8	-	-5.4	○	
		F548	150	200	0	-	+0.9	○	
	DAFFNEY HYDRAULIC FLUID 44 (IDEMITSU)	A505	100	70	+1	+8	-0.9	○	
		A505	100	70	-6	+4	+5.4	○	
	HIGH LAND 26 (NISSEKI)	A903	100	70	-3	-5	+3.0	○	
		A104	120	70	+4	+4	-3.9	○	
	HYDRAX 56 (KYOSEKI)	A105	120	70	0	-13	-0.7	○	
		A305	120	70	0	-2	-0.7	○	
		A505	120	70	0	-12	-0.9	○	
		A626	120	70	+1	+1	-1.4	○	
		A980	120	70	-2	-14	+2.2	○	
		DIAMOND LUB RO32 (MITSUBISHI PETROL)	A505	100	70	+1	+10	-0.3	○
			U641	100	1000	+1	+2	+0.2	○
	U801		100	1000	0	-33	+1.3	○	
	TERASSE OIL C10 (SHOWA-SHELL)	A795	100	200	+4	-	-1.8	○	
		F548	150	200	-1	-	+2.7	○	
		U801	100	200	-1	+2	+2.6	○	
		A505	100	240	-1	+2	-0.5	○	
	MITSUI HITEC 150 (MITSUI PETROL)	A505	100	500	+1	+8	-0.5	○	
				1000	+3	+8	-0.4	○	
A980		100	240	+1	+6	-1.6	○		
			500	+3	+6	-1.8	○		
			1000	+5	0	-2.3	○		
U593		100	1000	+1	+2	+0.8	○		
U641	100	1000	0	-15	+1.9	○			
U801	100	1000	0	0	-0.1	○			
WEAR RESISTANT HYDRAULIC OIL	DAFFNEY SUPER HYDRAULIC FLUID 32 (IDEMITSU)	U593	100	168	+1	+7	+0.8	○	
		U801	100	168	+1	-5	-0.7	○	
	DAFFNEY SUPER HYDRO32 (IDEMITSU)	U801	100	600	0	+10	+0.5	○	
	DAFFNEY SUPER HYDRAULIC FLUID 46 (IDEMITSU)	G506	100	1000	+6	-11	-0.9	○	
				120	500	+5	-15	-0.8	○

OIL RESISTANCE DATA

Brand name of sealing fluid (Manufacturer)	NOK's material code	Test temperature (°C)	Duration of test (H)	Change in hardness (points)	Change in tensile strength (%)	Change in volume (%)	compatibility
DAFFNEY SUPER HYDRO 46 (IDEMITSU)	U593	100	500	0	-2	+1.0	○
	U801	100	500	0	+12	+0.4	○
DAFFNEY SUPER HYDRAULIC FLUID 56 (IDEMITSU)	A104	100	70	+1	+5	-4.4	○
	A105	100	70	0	-12	-1.0	○
	A305	100	70	-2	-3	-1.7	○
	A505	100	70	-1	-5	-0.8	○
	A626	100	70	0	+4	-4.3	○
	A980	100	70	+3	+3	-2.2	○
DAFFNEY SUPER HYDRAULIC FLUID 100 (IDEMITSU)	G506	100	1000	+7	-4	-2.8	○
		120	500	+5	-8	-2.8	○
DAFFNEY SUPER HYDROLW46 (IDEMITSU)	A305	100	70	-5	+3	-0.1	○
			240	-4	+1	-1.5	○
			500	-3	+1	-2.5	○
	A795	100	70	+6	-	-5.4	○
	A980	100	70	-1	+2	+0.2	○
			240	0	0	+0.2	○
			500	0	-8	+0.6	○
U641	100	1000	-1	-7	+0.2	○	
U801	100	1000	0	-4	-0.4	○	
DAFFNEY SUPER HYDROLW46H (IDEMITSU)	A105	100	70	0	-3	-0.8	○
			168	+1	-3	-1.0	○
	A305	100	70	-1	-4	-0.1	○
			168	-2	+1	-0.9	○
	A980	100	70	-2	-4	+1.8	○
			168	0	-5	+0.9	○
U593	100	168	0	+3	-0.7	○	
U801	100	1000	-1	-34	-0.8	○	
SUPER HIGH LAND 32 (NISSEKI)	A104	120	70	+3	-3	-2.5	○
	A105	120	70	-1	-10	+0.4	○
	A305	120	70	-1	+1	+0.5	○
	A505	120	70	-1	-9	-1.6	○
	A626	120	70	-1	-6	+0.9	○
	A980	120	70	-3	-11	+4.9	○
	U801	100	1800	0	+12	+0.8	○
	U801	100	1000	0	+2	+0.2	○
SUPER HIGH LAND 56 (NISSEKI)	A104	120	70	+4	+3	-3.9	○
	A105	120	70	-1	-9	-0.6	○
	A305	120	70	-2	-3	-0.4	○
	A505	120	70	+3	-4	-2.3	○
	A626	120	70	0	-15	-1.0	○
	A980	120	70	-2	-16	+2.8	○
	U641	100	1000	-1	+8	-0.3	○
	U801	100	1000	0	+2	+0.2	○
COSMO HYDRO AW32 (COSMO)	A305	100	70	-2	+1	-0.3	○
			168	-1	+1	-1.3	○
	A980	100	70	+1	+4	+0.6	○
			168	+2	-4	+0.1	○
	U593	100	168	0	-13	+0.9	○
U801	100	168	0	+14	-0.9	○	
COSMO HYDRO AW46 (COSMO)	A305	100	70	-3	-1	-0.7	○
			168	-2	-4	-1.8	○
	A980	100	70	+1	+3	-0.3	○
			168	+2	-1	-0.7	○
	U593	100	168	0	-10	+0.8	○
U801	100	168	0	+9	-1.1	○	
COSMO HYDRO AW68 (COSMO)	A305	100	70	-1	+1	-1.5	○
			168	0	-1	-2.3	○
	A980	100	70	+1	+5	-1.3	○
			168	+3	0	-1.7	○
	U593	100	168	0	-16	+0.4	○
U801	100	168	0	+12	-1.1	○	
COSMO HYDRO LF22 (COSMO)	A305	100	70	-4	-4	+3.4	○
			168	-4	-7	+2.4	○

Wear resistant hydraulic oil

OIL RESISTANCE DATA

Brand name of sealing fluid (Manufacturer)	NOK's material code	Test temperature (°C)	Duration of test (H)	Change in hardness (points)	Change in tensile strength (%)	Change in volume (%)	compatibility
COSMO HYDRO LF22 (COSMO)	A980	100	70	-6	-1	+8.2	○
			168	-4	-9	+7.9	
	U593	100	168	0	+4	+3.2	○
COSMO HYDRO AW56KS (COSMO)	U801	100	168	0	+1	+1.1	○
	U593	100	70	-1	-4	+0.8	○
	U641	100	70	0	+2	+0.3	○
COSMO HYDRO HV15 (COSMO)	U801	100	70	0	+1	-0.7	○
	A305	100	70	-4	-4	+2.5	○
			168	-3	+3	+1.5	
A980	100	70	-8	-7	+6.9	○	
KYOSEKI HYDRAX LT15 (KYOSEKI)	A903	80	70	-6	0	+7.2	○
			100	70	-7	+1	
	U593	100	500	-6	-56	+3.0	○
KYOSEKI HYDRAX LT32 (KYOSEKI)	U801	100	500	-1	-34	+0.2	○
			1000	-1	-71	+0.4	
	U801	100	1000	-1	-71	+0.4	×
DIAMOND HYDRO FLUID EP46 (MITSUBISHI PETROL)	A980	100	70	0	-1	-1.1	○
TERRASSE OIL 32 (SHOWA-SHELL)	U641	100	1000	0	-11	+0.8	○
	U801	100	1000	+1	-39	+0.2	○
TERRASSE OIL K32 (SHOWA-SHELL)	U801	100	500	0	+5	+0.8	○
TERRASSE OIL 45 (SHOWA-SHELL)	U641	100	1000	-1	-49	+1.7	○
			500	0	-10	+0.1	
	U801	100	1000	+1	-77	-1.5	×
TERRASSE OIL 46 (SHOWA-SHELL)	U641	100	144	-1	+4	+1.0	○
			120	144	-1	-4	
	U801	100	144	0	-7	-0.5	○
			120	144	0	-10	
TERRASSE OIL K46 (SHOWA-SHELL)	G506	100	168	0	-3	-2.0	○
			120	168	-1	-2	
TERRASSE OIL 56 (SHOWA-SHELL)	A104	120	70	+4	+1	-3.8	○
	A105	120	70	0	-21	-0.5	○
	A305	120	70	-1	-1	-0.5	○
	A505	120	70	+1	-20	-1.2	○
	A626	120	70	-2	-2	-1.2	○
	A980	120	70	-2	-6	+2.4	○
	U641	100	1500	0	-6	+1.4	○
	U801	100	1500	0	-42	-0.5	○
TERRASSE OIL K100 (SHOWA-SHELL)	G506	100	168	+1	+4	-1.5	○
			120	168	+2	-3	
NUTOHH15 (ESSO)	A305	100	70	-4	-5	+2.9	○
			168	-3	-1	+2.1	
	A980	100	70	-5	-4	+7.2	○
			168	-6	-15	+6.6	
	U593	100	168	-4	-14	+3.0	△
U801	100	168	-1	-8	+0.9	○	
NUTOHHP68 (ESSO)	A104	120	70	+4	+5	-3.1	○
	A105	120	70	-1	-7	+0.7	○
	A305	120	70	-2	+4	+0.4	○
	A505	120	70	-1	-8	+0.3	○
	A626	120	70	0	+2	-1.0	○
	A980	120	70	-2	-6	+1.8	○
UNIPOWER SQ32 (ESSO)	U593	100	168	+1	-4	+1.8	○
	U801	100	168	+1	-3	-0.1	○
UNIPOWER SQ48 (ESSO)	U593	100	168	+1	-1	+1.7	○
	U801	100	168	+1	0	-0.1	○
UNIPOWER SQ68 (ESSO)	U593	100	168	+1	-3	+1.3	○
	U801	100	168	+1	-6	-0.3	○
MOBIL DTE26 (MOBIL)	A104	120	70	+5	-5	-4.2	○
	A105	120	70	+1	-15	-0.9	○
	A305	120	70	0	-4	-1.1	○

Wear resistant hydraulic oil

OIL RESISTANCE DATA

Brand name of sealing fluid (Manufacturer)		NOK's material code	Test temperature (°C)	Duration of test (H)	Change in hardness (points)	Change in tensile strength (%)	Change in volume (%)	compatibility
Wear resistant hydraulic oil	MOBIL DTE 26 (MOBIL)	A505	120	70	+ 1	-15	- 1.8	○
		A626	120	70	0	-11	- 2.2	○
		A980	120	70	0	-19	- 0.8	○
		U801	100	1000	+ 1	+20	+ 0.6	○
	MITSUI HIDICK AW46 (MITSUI PETROL)	A505	100	240	+ 1	+ 3	- 0.7	○
			500	+ 1	+ 3	- 0.8	○	
			1000	+ 3	+ 3	- 0.8	○	
		A980	100	240	+ 1	- 2	+ 0.6	○
			500	+ 3	- 3	+ 0.4	○	
			1000	+ 5	- 8	+ 0.1	○	
U801	100	1000	0	- 1	- 0.4	○		
U593	100	1000	+ 1	+ 7	+ 0.2	○		
U641	100	1000	0	-11	+ 0.4	○		
Wear resistant hydraulic oil (with improved viscosity and temperature characteristics)	DAFFNEY SUPER HYDRO 22WR (IDEMITSU)	U593	100	168	+ 1	- 1	+ 3.1	○
		U801	100	168	+ 1	+ 6	+ 1.1	○
	DAFFNEY SUPER HYDRO 32WR (IDEMITSU)	A104	100	70	- 2	+10	- 2.6	○
		A105	100	70	- 1	-12	+ 0.5	○
		A305	100	70	- 3	- 2	+ 0.3	○
		A505	100	70	- 2	0	+ 0.9	○
		A626	100	70	- 3	+ 3	- 1.3	○
		A980	100	70	- 5	+ 6	+ 2.1	○
	DAFFNEY SUPER HYDRO 46WR (IDEMITSU)	U593	100	1000	0	- 8	+ 0.1	○
		U641	100	1000	0	+18	+ 0.1	○
		U801	100	1000	+ 1	+ 7	- 1.2	○
	HIGH LAND WIDE 15 (NISSEKI)	A305	100	70	- 6	- 6	+ 4.3	○
			168	- 5	- 5	+ 3.3	○	
		A980	100	70	-10	- 3	+10.1	○
			168	- 9	- 1	+ 9.6	○	
	U593	100	168	- 2	+ 5	+ 4.4	○	
	U801	100	168	- 1	- 6	+ 1.8	○	
	HIGH LAND AH15 (NISSEKI)	A505	100	70	- 4	- 2	+ 4.9	○
		A903	100	70	- 1	- 5	+ 1.8	○
	COSMO HYDRO DHV32 (COSMO)	U593	120	1000	- 1	-27	+ 0.2	○
		U801	120	1000	0	-45	- 1.6	○
	COSMO HYDRO DHV56 (COSMO)	U593	100	1000	- 4	-41	+ 0.8	○
		U801	100	1000	0	-43	- 0.9	○
	TERRASSE OIL KT32 (SHOWA-SHELL)	G506	120	168	0	+ 1	+ 0.6	○
	TERRASSE OIL R32 (SHOWA-SHELL)	U641	120	300	0	+ 3	+ 1.2	○
		U801	120	300	0	- 2	- 0.1	○
	DIAMOND HYDRO-FLUID W32 (MITSUBISHI PETROL)	U801	100	1130	0	+12	+ 0.6	○
	MOBIL DTE11 (MOBIL)	A305	100	70	- 4	-13	+ 2.1	○
			168	- 4	-10	+ 3.4	○	
		A980	100	70	- 5	- 4	+10.3	○
168			- 5	0	+10.6	○		
U593		100	168	- 2	- 4	+ 4.0	○	
U801	100	168	- 1	- 1	+ 2.0	○		
MOBIL DTE13 (MOBIL)	A104	120	70	+ 2	- 9	- 1.0	○	
	A105	120	70	- 1	-19	+ 1.6	○	
	A305	120	70	- 2	-11	+ 2.1	○	
	A505	120	70	0	-17	+ 0.5	○	
	A626	120	70	- 3	-21	+ 2.8	○	
	A980	120	70	- 5	-16	+ 7.5	○	
	U801	100	1000	0	+ 9	+ 2.0	○	
		168	- 6	- 8	+ 4.1	○		
Worn gear oil	OMARA OIL 150 (SHOWA-SHELL)	U801	100	168	0	0	0	○
	Flame resistant hydraulic oil (Phosphate)	HIGH LAND FRP46 (NISSEKI)	A795	100	200	-30	-	+97.4
F384			80	168	- 1	+ 6	+ 1.9	○
F548			100	200	- 4	-	+12.1	○
FIREQUEIL 220 (COSMO)	F384	80	168	- 1	+15	+ 1.2	○	
	SFR FLUID D46 (SHOWA-SHELL)	A505	100	70	-19	-67	+77.5	×
		F268	100	70	- 5	+ 3	+ 3.0	○
				168	- 6	- 8	+ 4.1	○

OIL RESISTANCE DATA

Brand name of sealing fluid (Manufacturer)		NOK's material code	Test temperature (°C)	Duration of test (H)	Change in hardness (points)	Change in tensile strength (%)	Change in volume (%)	compatibility	
Phosphate)	SFR FLUID D46 (NISSEKI)	F384	80	168	-1	+8	+1.3	○	
		F480	100	70	-1	-1	+2.5	○	
			168		-2	-11	+3.7	○	
	LEOLUBE HYD110 (SHOWA-SHELL)	F384	80	168	0	+7	+1.6	○	
	MOBIL BILOGUARD53 (MOBIL)	F384	80	168	-1	+9	+1.1	○	
	NEO-LUBE (MATSUMURA PETROL)	F384	80	168	-1	+8	+0.9	○	
	Fatty acid ester base)	COSMO LUBRIC HF130 (E.F. HORTON)	G506	100	70	-4	+2	+3.1	○
				240		-3	+2	+3.9	○
				500		-3	+1	+4.5	○
			120	70	-3	+1	+3.8	○	
				240	-3	+2	+4.1	○	
				500	-2	+8	+5.4	○	
		U641	80	500	0	+12	+2.2	○	
			100	500	0	-7	+2.4	○	
			120	500	0	-37	+2.8	○	
QUINTLEPLIC 822-200 (JAPAN QUAKER CHEMICAL)		F384	100	70	-4	+7	+7.1	○	
QUINTLEPLIC 822-300 (JAPAN QUAKER CHEMICAL)		A402	100	70	-8	-19	+9.1	○	
		A505	100	70	-6	+6	+7.3	○	
		A980	100	70	-13	-11	+16.0	○	
		F201	100	70	-3	-5	+0.4	○	
		F480	100	70	0	-2	0	○	
	F384	100	70	-7	-16	+8.3	△		
HIGH LAND FRG46 (NISSEKI)	A104	100	70	-8	-1	+4.2	○		
	A402	100	70	-8	-18	+8.4	○		
	A505	100	70	-3	0	+2.6	○		
	A980	100	70	-3	-6	0	○		
	F384	100	70	-7	-16	+8.3	△		
COSMO FLUID HQ46 (COSMO)	U801	40	70	0	+11	+2.1	○		
		50	70	0	+8	+2.1	○		
		60	70	-1	-1	+3.1	△		
IRUS FLUID (SHOWA-SHELL)	A104	100	70	-6	-7	+0.8	○		
	A402	100	70	-5	-22	+1.9	○		
	A505	100	70	0	+6	+0.8	○		
	A980	100	70	-1	-7	-1.1	○		
	F384	100	70	-4	-20	+3.5	△		
HI-DOLL HAW (MATSUMURA PETROL)	A104	100	70	-8	-2	+5.6	○		
		100	70	-6	-9	+10.0	○		
		70	70	-3	+10	+4.4	○		
		100	70	-4	-2	+5.7	○		
	A980	70	70	-2	0	+2.6	○		
		100	70	-2	-8	+0.4	○		
		F384	100	70	-7	-15	+8.6	△	
		F268	175	70	-14	-27	+26.7	△	
HI-DOLL H200 (MATSUMURA PETROL)	F480	175	70	-12	-98	+72.9	×		
	A105	70	70	-1	-3	+2.3	○		
HORTSAFE (E.F.HORTON)	A105	240		-2	0	+3.4	○		
		500		-2	-2	+6.1	○		
		1000		+3	-10	+2.8	○		
		70	70	-4	-6	+2.8	○		
	A305	240		-6	-3	+5.4	○		
		500		-6	-7	+9.3	○		
		1000		-4	-6	+3.7	○		
		70	70	-2	-6	+1.9	○		
	A980	240		-3	-1	+2.1	○		
		500		-3	-2	+2.1	○		
		1000		+2	-10	-2.9	○		
		70	70	0	-7	+2.3	○		
HYDROLUBLIC 120B 5% SOLUTION (E.F. HORTON)	U641	80	420	-1	-25	+2.7	○		
		80	250	-2	-40	+4.0	△		
	U801	60	420	-1	-13	+3.2	○		
		80	250	-2	-40	+4.0	△		
DAFFNEY FURTHEST WO46 (IDEMITSU)	A505	80	168	-7	-3	+13.4	○		
		500		-8	-4	+12.9	○		
	A795	80	168	-10	-9	+11.7	○		
		500		-12	-15	+12.1	△		

OIL RESISTANCE DATA

Brand name of sealing fluid (Manufacturer)		NOK's material code	Test temperature (°C)	Duration of test (H)	Change in hardness (points)	Change in tensile strength (%)	Change in volume (%)	compatibility
Flame retardant hydraulic oil (Water soluble oil)	DAFFNEY FURTHEST W046 (IDEMITSU)	A980	80	168	-13	-7	+26.3	○
				500	-19	-5	+29.7	○
		G506	80	168	-6	-19	+9.7	○
				500	-13	-21	+9.8	○
		U641	80	168	-4	-35	+9.7	○
				500	-4	-51	+9.9	×
Bearring oil	DAFFNEY SUPER MULTI-OIL32 (IDEMITSU)	U801	80	70	0	+5	+0.6	○
TURBINE OIL	140 TURBINE OIL (IDEMITSU)	A505	100	70	0	0	-0.7	○
	180 TURBINE OIL (IDEMITSU)	A505	100	70	+1	+3	-0.9	○
	FBK TURBINE 90 (NISSEKI)	A105	100	70	-2	-3	+1.7	○
		A305	100	70	-2	-14	+0.5	○
		A505	100	70	-3	-8	+0.9	○
	TURBINE OIL 32 (NISSEKI)	U801	100	1000	+1	+2	+0.7	○
Group base oil	UNIWAY 68 (NISSEKI)	U801	100	1000	+1	+17	+1.5	○
Machine oil	No.2 SPINDLE OIL (NISSEKI)	A105	100	70	-5	-4	+9.4	○
		A305	100	70	-9	-22	+10.8	○
		A505	100	70	-6	-10	+9.7	○
		F548	120	200	0	-	+1.6	○
SYNTHETIC LUBRICANT (Silicone type)	KF96-350 (SHINETSU CHEMICAL)	U641	80	70	0	+3	-	○
	TSF45I-350 (TOSHIBA SILICONE)	U641	80	70	0	+11	-	○
GREASE FOR VEHICLES	APPOLOIL AUTOREX A (IDEMITSU)	A305	80	70	0	+3	+2.0	○
		A795	100	200	+5	-	-4.7	○
		U695	100	750	-1	-43	+1.3	○
			1000	-1	-56	+1.2	△	
	U801	80	500	0	-48	+3.8	○	
	APPOLOIL AUTOREX C (IDEMITSU)	U641	100	1000	-2	0	0	○
		U801	100	1000	-1	+15	+0.2	○
	DAFFNEY CORONEX GREASE No.2 (IDEMITSU)	U801	70	1000	-1	+9	+2.3	○
	DIAMOND MULTI-PURPOSE GREASE No.2 (IDEMITSU)	U801	70	1000	-1	+10	+2.6	○
	CHASSIS GREASE 2 (SHOWA-SHELL)	U801	100	168	0	+18	+3.4	○
	ALBANIA GREASE 2 (SHOWA-SHELL)	U801	100	500	0	-57	+2.4	×
	ALBANIA GREASE RA (SHOWA-SHELL)	U801	100	500	0	-70	+2.2	×
	ALBANIA EP GREASE 2 (SHOWA SHELL)	U641	100	500	-3	-10	+3.0	○
		U801	100	500	-2	-75	+3.9	×
	SUNLIGHT GREASE 2 (SHOWA SHELL)	U801	100	168	0	0	+2.4	○
	CHASSIS GREASE No.2 (NISSEKI)	U695	100	1000	-2	-15	+4.7	○
			120	1000	-2	-35	+5.3	○
	SEMI-COAT GREASE No.2 (GENERAL PETROL)	U801	80	168	0	-13	+2.4	○
	CENTPLEX 2 (NOK KLUEBER)	A305	100	70	-7	+1	+1.9	○
			168	-5	+1	+1.2	○	
		A980	100	70	-5	+5	+5.0	○
			168	-4	0	+4.5	○	
		U593	100	168	0	-1	+0.3	○
		U801	100	168	-1	-69	+1.0	×
	ONE LOOPER No. 2(KYODO GREASE)	A305	80	70	-7	+1	+4.9	○
	MARUTEMP TA No.2 (KYODO GREASE)	U801	100	168	0	+1	+2.4	○
	CASTLE MP GREASE (TOYOTA MOTORS GENUINE)	A305	80	70	-6	-4	+4.8	○
	CASTLE CHASSIS GREASE SPECIAL (TOYOTA MOTORS GENUINE)	U695	100	1000	-1	-9	+3.0	○
120			1000	-2	-15	+3.5	○	
BLUE RIBBON BEARING GREASE (HINO MOTOR SALES GENUINE)	A305	80	70	-6	+6	+2.9	○	
Industrial grease	MOBIL TAK 81 (MOBIL)	A505	100	1000	+4	-20	+0.4	○
		F480	100	1000	+3	-2	+0.8	○
	GOLD No.2 (JAPAN GREASE)	U801	100	168	0	+1	+2.7	○
	STABRUGGS NBU30G5 (NOK KLUEBER)	A505	100	1000	+6	+4	-0.3	○
F480		100	1000	+3	-2	+1.3	○	
SYNTHESSO PROBA270 (NOK GLUBER)	A168	100	70	-2	+6	+2.1	○	
Other grease	No115 SPRAY GREASE (NICHIMORI)	A305	100	70	-5	0	-2.3	○
			168	-4	+3	-3.2	○	
		A980	100	70	+2	+4	-3.5	○
		168	+3	+4	-3.6	○		

OIL RESISTANCE DATA

Brand name of sealing fluid (Manufacturer)		NOK's material code	Test temperature (°C)	Duration of test (H)	Change in hardness (points)	Change in tensile strength (%)	Change in volume (%)	compatibility	
Other greases	L-60 (NOK KLUEBER)	U593	100	100	-1	+5	+0.3	○	
		U641	100	100	-1	+8	+0.5	○	
	DAFFNEY SPRAY GREASE (IDEMITSU)	A305	100	70	-5	+2	+1.4	○	
		A980	100	70	-3	+1	+2.9	○	
			168	-5	+5	+0.6	○		
			168	-2	+2	+2.7	○		
PROCESSING OIL (Cutting oil / Laminating oil / Anti-rust oil)	YUSHILOKEN EC50T3 50% SOLUTION (YUSHIRO KAGAKU)	U641	80	168	-2	-13	+2.4	○	
		U801	80	168	-2	-13	+2.7	○	
	MOBIL MTJ-200C (MOBIL)	A505	100	70	-12	-2	+16.6	△	
		F480	100	70	-2	-11	+1.8	○	
	MOBIL MTJ-200C 6% SOLUTION (MOBIL)	U801	80	70	0	-49	+2.4	×	
		A104	80	70	-7	-3	+14.6	○	
	ST BOUSEI K2171 (MOBIL)	A505	80	70	-6	+2	+13.3	○	
		A104	25	70	-12	-14	+11.0	△	
		A505	25	70	-5	-10	+7.6	○	
Metal detergent oil	ANTI-CORROSION	A305	25	70	-3	-3	+2.2	○	
		A402	25	70	-3	-18	+2.5	○	
Crude oil	KUWAIT Crude oil	A505	60	70	-4	-16	+8.8	○	
Fuel oil	FUEL A	A105	25	70	-4	-21	+7.8	○	
	FUEL B	A105	25	70	-17	-53	+33.0	×	
		A305	25	70	-14	-48	+23.4	×	
	FUEL C	A305	40	70	-17	-61	+56.0	○	
			240	-17	-62	+55.0	×		
	F384	40	70	-6	-22	+11.0	○		
		240	-10	-30	+8.0	○			
	FUEL C + METHANOL (85 : 15)	A305	40	70	-18	-69	+94.0	○	
240			-18	-68	+94.0	×			
	F384	40	70	-15	-48	+28.0	○		
			240	-17	-48	+26.0	△		
Other hydraulic oil (Hydraulic oil for aviation) (Raw resolution hydraulic oil)	MIL H 5606	A980	120	70	-21	-19	+30.7	○	
	MIL H 5606 C	U801	100	500	-1	+5	+6.0	○	
	HYDRAULIC FLUID (SHOWA-SHELL)	A903	100	70	-4	-2	+6.2	○	
		AEROSHELL #4 (SHOWA-SHELL)	U593	100	70	-1	+16	+6.8	○
	U801		100	70	0	+6	+3.8	○	
	NATUREL HF (SHELL)	A105	120	70	-6	-8	+9.0	○	
			A305	100	70	-7	-2	+1.3	○
				240	-6	-4	+1.4	○	
			500	-6	-1	+1.5	○		
		A505	120	70	-4	+8	+8.8	○	
		A903	120	70	-5	-7	+15.4	△	
			A980	60	70	-7	+4	+7.9	○
		240		-10	0	+12.5	○		
		500		-12	+3	+13.5	○		
		80	70	-12	+5	+13.4	○		
			240	-12	-2	+13.8	○		
			500	-13	-10	+14.2	○		
	100	70	-13	-4	+15.1	○			
		240	-13	-6	+15.2	○			
		500	-14	-7	+15.6	○			
	120	70	-14	-6	+28.0	△			
	G506	120	70	-3	-7	+4.9	○		
	U593	60	500	-1	+14	+1.1	○		
80		500	-2	-7	+1.4	○			
100		500	-4	-50	+0.5	△			
U641	60	500	-1	+28	+0.7	○			
	80	500	-1	+8	+0.9	○			
	100	500	-1	+7	+1.6	○			
U801	80	500	0	+2	-0.7	○			
	100	500	0	-63	-1.4	×			
PANORIN HLP-SYNTH	U593	100	70	-2	+9	+6.7	○		
	U641	100	70	0	+10	+4.5	○		

OIL RESISTANCE DATA

Brand name of sealing fluid (Manufacturer)		NOK's material code	Test temperature (°C)	Duration of test (H)	Change in hardness (points)	Change in tensile strength (%)	Change in volume (%)	compatibility
Other hydraulic oil (Rare resolution hydraulic oil)	PANORIN HLP-SYNTH	U695	100	70	0	+12	+4.5	○
		U801	100	70	0	+3	+3.0	○
	COSMOLUBRIC HF-122	U593	100	70	-4	-24	+4.5	×
		U641	100	70	-1	+10	+2.0	○
		U695	100	70	0	0	+2.2	○
		U801	100	70	-2	-20	+1.5	×
		A105	120	70	-2	-19	+0.2	○
	PLANTO HYD-40	A305	120	70	-4	-3	+0.1	○
		A505	120	70	-4	+6	+1.9	○
		A980	120	70	-16	-3	+19.1	△
		F384	120	70	0	+6	-0.2	○
			175	70	0	+8	-1.3	○
		U593	100	1000	-2	-30	+0.4	○
		U641	100	1000	-1	-2	+1.4	○
		U695	100	70	0	+5	+0.8	○
		U801	100	1000	0	-26	-0.6	○
		MOBIL EAL 224H	U593	100	70	0	+4	+2.0
	U801		100	70	0	+12	0	○
	BP BIOHYD 46	U593	100	70	0	-6	+2.5	○
		U801	100	70	0	+2	+0.2	○
BP BIOHYD SE 46	U593	100	70	-1	-3	+3.5	○	
	U801	100	70	0	+2	+0.9	○	
FINA BIOHYDRAN RS 38	U593	100	70	-1	+1	+2.2	△	
	U801	100	70	0	-25	0	×	
TOTAL HYDROBIO 46	U593	100	70	0	+1	+3.6	○	
	U801	100	70	0	+6	+0.9	○	
Water and Vapor	A105	100	70	+3	-16	-0.1	○	
	A168	120	70	+5	-41	-0.8	△	
	A305	100	70	-4	-3	+3.8	○	
	A505	100	70	-1	-11	+3.8	○	
	F384	100	70	-2	-	+2.2	△	
	U641	25	35040	-1	-11	+0.5	○	
		U695	80	1000	0	-7	+1.4	○
	U801	98	1000	-2	-43	+1.5	○	
		70	1000	-1	-28	+1.0	○	
	100	200	-3	-79	+1.5	×		
Muddy water	U641	25	35040	-1	-11	+0.3	○	
COCA COLA	A104	25	100	-5	-	+1.4	○	
	A168	25	100	-1	-	+1.1	○	
	A305	25	100	-3	-	+1.4	○	
METHANOL	A305	40	70	-12	-41	+14.0	×	
		240	-10	-38	+12.0			
	F384	40	70	-13	-36	+20.0	△	
Others (Agricultural chemicals)	F384	240	-1	-40	+18	△		
		25	168	-2	-		+2.6	
	F384	25	70	-1	-	+1.2	○	
	F384	25	70	0	0	+0.5	○	
	F384	25	70	0	-6	+1.8	○	
	F384	25	70	0	-3	+1.5	○	
	F384	25	70	0	-1	+0.3	○	
	F384	25	70	0	-	+1.0	○	
	F384	25	70	+1	-1	+0.7	○	
	F384	25	70	0	-6	+1.9	○	
	F384	25	70	-3	-3	+1.9	○	
	F384	25	70	-1	-	+1.3	○	

FITTING TOLERANCE FOR SHAFT

FITTING TOLERANCE FOR SHAFT (JIS B 0401)

Unit: 0.001mm

Classification of nominal sizes (mm)	f5		f6		f7		f8		f9		f10		f11	
	Upper tolerance	Lower tolerance	Upper tolerance	Lower tolerance	Upper tolerance	Lower tolerance	Upper tolerance	Lower tolerance	Upper tolerance	Lower tolerance	Upper tolerance	Lower tolerance	Upper tolerance	Lower tolerance
1 - 3	+0.04	0	+0.12	0	+0.21	0	+0.30	0	+0.40	0	+0.50	0	+0.60	0
3 - 6	+0.06	0	+0.18	0	+0.27	0	+0.36	0	+0.45	0	+0.54	0	+0.63	0
6 - 10	+0.09	0	+0.24	0	+0.36	0	+0.48	0	+0.60	0	+0.72	0	+0.84	0
10 - 14	+0.12	0	+0.30	0	+0.45	0	+0.60	0	+0.75	0	+0.90	0	+1.05	0
14 - 18	+0.15	0	+0.36	0	+0.54	0	+0.72	0	+0.90	0	+1.08	0	+1.26	0
18 - 24	+0.18	0	+0.42	0	+0.63	0	+0.84	0	+1.05	0	+1.26	0	+1.47	0
24 - 30	+0.21	0	+0.48	0	+0.72	0	+0.96	0	+1.20	0	+1.44	0	+1.68	0
30 - 40	+0.24	0	+0.54	0	+0.81	0	+1.08	0	+1.35	0	+1.62	0	+1.89	0
40 - 50	+0.27	0	+0.60	0	+0.90	0	+1.20	0	+1.50	0	+1.80	0	+2.10	0
50 - 65	+0.30	0	+0.66	0	+0.99	0	+1.32	0	+1.65	0	+1.98	0	+2.31	0
65 - 80	+0.33	0	+0.72	0	+1.08	0	+1.44	0	+1.80	0	+2.16	0	+2.52	0
80 - 100	+0.36	0	+0.78	0	+1.17	0	+1.56	0	+1.95	0	+2.34	0	+2.73	0
100 - 120	+0.39	0	+0.84	0	+1.26	0	+1.68	0	+2.10	0	+2.52	0	+2.94	0
120 - 140	+0.42	0	+0.90	0	+1.35	0	+1.80	0	+2.25	0	+2.70	0	+3.15	0
140 - 160	+0.45	0	+0.96	0	+1.44	0	+1.92	0	+2.40	0	+2.88	0	+3.36	0
160 - 180	+0.48	0	+1.02	0	+1.53	0	+2.04	0	+2.52	0	+3.00	0	+3.48	0
180 - 200	+0.51	0	+1.08	0	+1.62	0	+2.16	0	+2.64	0	+3.12	0	+3.60	0
200 - 225	+0.54	0	+1.14	0	+1.71	0	+2.25	0	+2.73	0	+3.21	0	+3.69	0
225 - 250	+0.57	0	+1.20	0	+1.80	0	+2.34	0	+2.82	0	+3.30	0	+3.78	0
250 - 280	+0.60	0	+1.26	0	+1.89	0	+2.43	0	+2.91	0	+3.39	0	+3.87	0
280 - 315	+0.63	0	+1.32	0	+1.98	0	+2.52	0	+3.00	0	+3.48	0	+3.96	0
315 - 355	+0.66	0	+1.38	0	+2.07	0	+2.61	0	+3.09	0	+3.57	0	+4.05	0
355 - 400	+0.69	0	+1.44	0	+2.16	0	+2.70	0	+3.18	0	+3.66	0	+4.14	0
400 - 450	+0.72	0	+1.50	0	+2.25	0	+2.79	0	+3.27	0	+3.75	0	+4.23	0
450 - 500	+0.75	0	+1.56	0	+2.34	0	+2.88	0	+3.36	0	+3.84	0	+4.32	0

FITTING TOLERANCE FOR BORE

FITTING TOLERANCE FOR BORE (JIS B 0401)

Unit: 0.001mm

Classification of nominal sizes (mm)	IT 6		IT 7		IT 8		IT 9		IT 10		IT 12		H 12 Upper tolerance Lower tolerance																					
	M6	K6	J6	H6	G6	F6	F7	E7	F8	D8	F9	D9		F10	D10	F12	D12																	
1 - 3	-2	0	2	6	8	12	-14	-10	-6	-4	-2	0	3	10	12	16	24	14	+14	+20	+28	+34	25	+25	+35	+45	+55	40	+40	+60	+100	+160	+100	0
3 - 6	-1	2	4	8	12	18	-15	-11	-8	-4	0	3	5	12	16	22	32	18	+18	+28	+38	+48	30	+30	+50	+80	+120	48	+48	+78	+118	+168	+120	0
6 - 10	-3	2	5	9	14	22	-17	-13	-9	-4	0	5	8	15	20	28	40	22	+22	+35	+47	+62	36	+36	+61	+76	+116	58	+58	+96	+138	+208	+150	0
10 - 14	-4	2	6	11	17	27	-20	-16	-11	-5	0	6	10	16	24	34	50	27	+27	+43	+59	+77	43	+43	+75	+93	+136	70	+70	+120	+165	+250	+180	0
14 - 18	-5	3	7	13	20	32	-23	-19	-14	-8	0	7	12	18	28	40	60	32	+32	+50	+68	+90	50	+50	+85	+115	+170	80	+80	+130	+180	+270	+210	0
18 - 24	-6	4	10	17	26	41	-27	-20	-14	-7	0	8	13	21	32	47	71	40	+40	+60	+82	+110	62	+62	+105	+145	+215	100	+100	+160	+220	+330	+250	0
24 - 30	-7	5	12	20	30	47	-31	-24	-17	-9	0	9	14	25	38	55	83	46	+46	+70	+96	+130	74	+74	+124	+174	+264	120	+120	+200	+280	+420	+300	0
30 - 40	-8	6	14	23	34	53	-35	-28	-20	-11	0	10	16	28	43	64	97	52	+52	+80	+110	+150	82	+82	+135	+195	+295	130	+130	+230	+330	+510	+350	0
40 - 50	-10	8	17	28	41	63	-40	-33	-25	-14	0	11	18	31	48	72	110	60	+60	+95	+135	+185	90	+90	+155	+225	+345	150	+150	+270	+390	+580	+400	0
50 - 65	-12	10	21	34	50	75	-45	-38	-29	-17	0	12	20	35	54	82	125	68	+68	+105	+150	+210	100	+100	+180	+270	+400	180	+180	+330	+480	+720	+500	0
65 - 80	-15	13	26	42	62	93	-51	-44	-35	-21	0	13	22	38	59	89	135	76	+76	+115	+165	+235	110	+110	+200	+300	+450	200	+200	+380	+550	+850	+600	0
80 - 100	-18	16	31	50	73	110	-57	-50	-41	-25	0	14	25	43	67	102	155	84	+84	+125	+180	+260	120	+120	+230	+350	+520	220	+220	+420	+620	+950	+700	0
100 - 120	-20	18	35	56	82	125	-63	-56	-47	-29	0	15	28	48	74	112	170	92	+92	+135	+195	+285	140	+140	+270	+400	+600	250	+250	+480	+700	+1050	+800	0
120 - 140	-22	20	39	62	91	138	-69	-62	-53	-33	0	16	30	52	80	120	180	100	+100	+145	+210	+300	160	+160	+320	+480	+720	300	+300	+580	+850	+1300	+1000	0
140 - 160	-25	23	44	70	103	155	-75	-68	-59	-37	0	17	33	58	88	130	195	110	+110	+155	+225	+325	180	+180	+360	+540	+810	350	+350	+680	+1000	+1500	+1100	0
160 - 180	-28	26	50	80	117	175	-81	-74	-65	-41	0	18	36	64	98	145	215	120	+120	+165	+240	+345	200	+200	+400	+600	+900	400	+400	+800	+1200	+1800	+1300	0
180 - 200	-30	28	55	88	125	188	-87	-80	-71	-45	0	19	39	70	106	155	230	130	+130	+175	+255	+365	220	+220	+440	+660	+980	450	+450	+900	+1350	+2000	+1400	0
200 - 225	-33	31	61	96	138	205	-93	-86	-77	-49	0	20	42	76	116	170	250	140	+140	+185	+270	+385	240	+240	+480	+720	+1080	500	+500	+1000	+1500	+2200	+1500	0
225 - 250	-35	33	66	105	153	225	-99	-92	-83	-53	0	21	45	82	124	180	265	150	+150	+195	+285	+405	260	+260	+520	+780	+1170	550	+550	+1100	+1650	+2400	+1600	0
250 - 280	-38	36	73	115	170	255	-105	-98	-89	-57	0	22	49	90	136	200	295	160	+160	+205	+295	+425	280	+280	+560	+840	+1260	600	+600	+1200	+1800	+2700	+1700	0
280 - 315	-42	40	81	128	188	285	-111	-104	-95	-63	0	23	53	100	150	220	325	170	+170	+215	+305	+445	300	+300	+600	+900	+1350	650	+650	+1300	+1950	+2900	+1800	0
315 - 355	-45	44	89	140	205	315	-117	-110	-101	-67	0	24	57	110	165	240	355	180	+180	+225	+315	+465	330	+330	+660	+990	+1485	700	+700	+1400	+2100	+3150	+1900	0
355 - 400	-50	48	99	155	225	345	-123	-116	-107	-73	0	25	62	120	180	265	395	190	+190	+235	+325	+485	360	+360	+720	+1080	+1620	750	+750	+1500	+2250	+3375	+2000	0
400 - 450	-55	53	109	175	255	395	-129	-122	-113	-79	0	26	68	130	200	295	435	200	+200	+245	+335	+505	400	+400	+800	+1200	+1800	800	+800	+1600	+2400	+3600	+2100	0
450 - 500	-60	58	121	195	285	445	-135	-128	-119	-85	0	27	74	140	220	325	485	210	+210	+255	+345	+525	450	+450	+900	+1350	+2025	900	+900	+1800	+2700	+4050	+2200	0

Unit: 0.001mm

STANDARD FITTING TOLERANCE FOR LARGE DIAMETER (JIS B 0401)

Unit : 0.001mm

Classification of nominal sizes (mm)		Tolerance of shaft			Tolerance of hole			
		h 9	h 10	f 8	H 7	H 8	H 9	H 10
Above	Below	Upper tolerance			Upper tolerance			
500	630	0 -175	0 -280	-76 -186	+70 0	+110 0	+175 0	+280 0
630	800	0 -200	0 -320	-80 -205	+80 0	+125 0	+200 0	+320 0
800	1000	0 -230	0 -360	-86 -226	+90 0	+140 0	+230 0	+360 0
1000	1250	0 -260	0 -420	-96 -263	+105 0	+165 0	+260 0	+420 0
1250	1600	0 -310	0 -500	-110 -305	+125 0	+195 0	+310 0	+500 0
1600	2000	0 -370	0 -600	-120 -350	+150 0	+230 0	+370 0	+600 0

TABLE OF MAJOR SI UNIT CONVERSION Unit shown in bold line represents SI unit.

Force	N	dyn	kgf
	1	1×10^5	1.01972×10^{-1}
	1×10^{-5}	1	1.01972×10^{-5}
	9.80665	9.80665×10^5	1

Viscosity	Pa·s	cp	P
	1	1×10^3	1×10
	1×10^{-3}	1	1×10^{-2}
	1×10^{-1}	1×10^2	1

 Note : 1P = 1dyn·s/cm² = 1g/cm·s, 1Pa·s = 1N·s/m², 1cP = 1mPa·s

Pressure	Pa	kPa	MPa	bar	kgf/cm ²	atm	mmH ₂ O	mmHg 又は Torr
	1	1×10^{-3}	1×10^{-6}	1×10^{-1}	1.01972×10^{-1}	9.86923×10^{-4}	1.01972×10^{-1}	7.50062×10^2
	1×10^3	1	1×10^{-3}	1×10^{-2}	1.01972×10^{-2}	9.86923×10^{-3}	1.01972×10^2	7.50062
	1×10^6	1×10^3	1	1×10	1.01972×10	9.86923	1.01972×10^5	7.50062×10^3
	1×10^9	1×10^6	1×10^{-1}	1	1.01972	9.86923×10^{-1}	1.01972×10^8	7.50062×10^6
	9.80665×10^4	9.80665×10	9.80665×10^{-2}	9.80665×10^{-1}	1	9.67841×10^{-1}	1×10^4	7.35559×10^2
	1.01325×10^5	1.01325×10^2	1.01325×10^{-1}	1.01325	1.03323	1	1.03323×10^4	7.6000×10^2
	9.80665	9.80665×10^{-3}	9.80665×10^{-6}	9.80665×10^{-5}	1×10^{-4}	9.67841×10^{-5}	1	7.35559×10^{-2}
	1.33322×10^5	1.33322×10^{-1}	1.33322×10^{-4}	1.33322×10^{-3}	1.35951×10^{-2}	1.31579×10^{-3}	1.35951×10	1

 Note : 1P = 1N/cm²

Stress	Pa or N/m ²	MPa or N/mm ²	kgf	kgf/cm ²
	1	1×10^{-6}	1.01972×10^{-7}	1.01972×10^{-5}
	1×10^6	1	1.01972×10^{-1}	1.01972×10
	9.80665×10^5	9.80665	1	1×10^2
	9.80665×10^4	9.80665×10^{-2}	1×10^{-2}	1

 Note : 1Pa = 1N/cm², 1MPa = 1N/mm²

Dynamic viscosity	m ² /s	cSt	St
	1	1×10^6	1×10^4
	1×10^{-6}	1	1×10^2
	1×10^{-4}	1×10^2	1

 Note : 1St = 1cm²/s, 1cSt = 1mm²/s

TABLE OF HARDNESS CONVERSION

Approximate conversion value for Rockwell ASTM hardness C of steel					
Hardness by Rockwell C scale	Vickers hardness	Rockwell hardness		Shore hardness	Hardness by Rockwell C scale
		Brinell hardness 30kg Standard ball	Rockwell hardness 1/16 inch 150kg Dia. of ball 1/16 in.		
68	940	—	—	97	68
67	900	—	—	95	67
66	865	—	—	92	66
65	832	—	—	91	65
64	800	—	—	88	64
63	772	—	—	87	63
62	746	—	—	85	62
61	720	—	—	83	61
60	697	—	—	81	60
59	674	—	—	80	59
58	653	—	—	78	58
57	633	—	—	76	57
56	613	—	—	75	56
55	595	—	—	74	55
54	577	—	—	72	54
53	560	—	—	71	53
52	544	500	—	69	52
51	528	487	—	68	51
50	513	475	—	67	50
49	498	464	—	66	49
48	484	451	—	64	48
47	471	442	—	63	47
46	458	432	—	62	46
45	446	421	—	60	45
44	434	409	—	58	44
43	423	400	—	57	43
42	412	390	—	56	42
41	402	381	—	55	41
40	392	371	—	54	40
39	382	362	—	52	39
38	372	358	—	51	38
37	363	344	—	50	37
36	354	336	(109.0)	49	36
35	345	327	(108.5)	48	35
34	336	319	(108.0)	47	34
33	327	311	(107.5)	46	33
32	318	301	(107.0)	44	32
31	310	294	(106.0)	43	31
30	302	286	(105.5)	42	30
29	294	279	(104.5)	41	29
28	286	271	(104.0)	41	28
27	279	264	(103.0)	40	27
26	272	258	(102.5)	38	26
25	266	253	(101.5)	38	25
24	260	247	(101.0)	37	24
23	254	243	(100.0)	36	23
22	248	237	(99.0)	35	22
21	243	231	(98.5)	35	21
20	238	226	97.8	34	20
(18)	230	219	96.7	33	(18)
(16)	222	212	95.5	32	(16)
(14)	213	203	93.9	31	(14)
(12)	204	194	92.3	29	(12)
(10)	196	187	90.7	28	(10)
(8)	188	179	89.5	27	(8)
(6)	180	171	87.1	26	(6)
(4)	173	165	85.5	25	(4)
(2)	166	158	83.5	24	(2)
(0)	160	152	81.7	24	(0)

RANGE OF ROUGHNESS BY VARIOUS METHODS OF PROCESSING

Surface roughness Rmax		0.15	0.25	0.45	0.85	1.65	3.25	6.35	12.55	255	505	1005	2005	4005
Range of roughness μm		0.1	0.2	0.4	0.8	1.5	3	6	12	25	50	100	200	400
Method of processing		≤1/2	≤1/2	≤1/2	≤1/2	≤1/2	≤1/2	≤1/2	≤1/2	≤1/2	≤1/2	≤1/2	≤1/2	≤1/2
Symbols		No symbols or												
Forging	FG													
Casting	C													
Die casting	DC													
Hot rolling	HR													
Cold rolling	CR													
Drawing	DW													
Extrusion	EX													
Tumbling	TU													
Sand-blasting	SB													
Roll lining	RL													
Triangle signs		▽▽▽▽			▽▽▽			▽▽			▽			
Face milling	FM													
Planing	P													
Slotting	SL													
Milling	M													
Fine boring	FB													
Filing finish	FF													
Turning	T													
Boring	B													
Drilling	D													
Reaming	DR													
Broaching	BR													
Shaving	SV													
Grinding	G													
Honing finish	GH													
Super finish	GSP													
Buffing finish	SPBF													
Paper finish	FCA													
Lapping finish	FL													
Liquid honing	SPLH													
Burnishing	RLB													
Roller finish	RF													
Chemical polishing	SPC													
Electrolytic polishing	SPE													

TABLE OF ROUGHNESS CONVERSION

Center line average roughness Ra	Maximum height Rmax	10 point average roughness Rz	Triangle signs
0.013a	0.055	0.05Z	▽▽▽▽
0.025a	0.15	0.1Z	
0.05a	0.25	0.2Z	
0.10a	0.45	0.4Z	
0.20a	0.85	0.8Z	
0.40a	1.65	1.6Z	▽▽▽
0.80a	3.25	3.2Z	
1.6a	6.35	6.3Z	
3.2a	12.55	12.5Z	▽▽
6.3a	255	25Z	
12.5a	505	50Z	▽
25a	1005	100Z	
50a	2005	200Z	—
100a	4005	400Z	

Table of viscosity conversion

Seyboldt SUS (sec)	Red wood R (sec)	Engler E (sec)	Centi-stokes cSt	Seyboldt SUS (sec)	Red wood R (sec)	Engler E (sec)	Centi-stokes cSt
35	32.2	1.18	2.7	475	419	13.5	103
40	36.2	1.32	4.3	500	441	14.2	108
45	40.6	1.46	5.9	550	485	15.6	119
50	44.9	1.60	7.4	600	529	17.0	130
55	49.1	1.75	8.9	650	573	18.5	141
60	53.5	1.88	10.4	700	617	19.9	152
65	57.9	2.02	11.8	750	661	21.3	163
70	62.3	2.15	13.1	800	705	22.7	173
75	67.6	2.31	14.5	850	749	24.2	184
80	71.0	2.42	15.8	900	793	25.6	195
85	75.1	2.55	17.0	950	837	27.0	206
90	79.6	2.68	18.2	1000	882	28.4	217
95	84.2	2.81	19.4	1200	1058	34.1	260
100	88.4	2.95	20.6	1400	1234	39.8	302
110	97.1	3.21	23.0	1600	1411	45.5	347
120	105.9	3.49	25.0	1800	1587	51	390
130	114.8	3.77	27.5	2000	1763	57	433
140	123.6	4.04	29.8	2500	2204	71	542
150	132.4	4.32	32.1	3000	2646	85	650
160	141.1	4.59	34.3	3500	3087	99	758
170	150.0	4.88	36.5	4000	3526	114	867
180	158.8	5.15	38.8	4500	3967	128	974
190	167.5	5.44	41.0	5000	4408	142	1082
200	176.4	5.72	43.2	5500	4849	156	1150
220	194	6.28	47.5	6000	5290	170	1300
240	212	6.85	51.9	6500	5730	185	1400
260	229	7.38	56.5	7000	6171	199	1510
280	247	7.95	60.5	7500	6612	213	1630
300	265	8.51	64.9	8000	7053	227	1740
325	287	9.24	70.3	8500	7494	242	1850
350	309	9.95	75.8	9000	7943	256	1960
375	331	10.7	81.2	9500	8375	270	2070
400	353	11.4	86.8	10000	8816	284	2200
425	375	12.1	92.0				
450	397	12.8	97.4				

How to read the Table :

For example, when converting 38°C into °F, find out 38 from the 2nd row of the table (10th position from the top) at the center column and then read the figure in the column °F on the right side. You will thus find out 100.4°F. To the contrary, you can convert 38°F into °C by reading the figure in the column °C on the left side and then you can know that it correspond to 33°C.

Table of temperature conversion

$$C = \frac{5}{9}(F - 32) \quad F = \frac{9}{5}(C + 32)$$

°C ← °F	°C → °F	°C ← °F	°C → °F	°C ← °F	°C → °F	°C ← °F	°C → °F				
-73	-100	-148	-1.6	29	84.2	17.7	64	147.2	37.1	99	210.2
-62	-80	-112	-1.1	30	86.0	18.2	65	149.0	37.7	100	212.0
-51	-60	-76	-0.6	31	87.8	18.8	66	150.8	38	100	212
-40	-40	-40	0	32	89.6	19.3	67	152.6	43	110	230
-29	-20	-4	0.5	33	91.4	19.9	68	154.4	49	120	248
-23.3	-10	14	1.1	34	93.2	20.4	69	156.2	54	130	266
-17.7	0	32	1.6	35	95.0	21.0	70	158.0	60	140	284
-17.2	1	33.8	2.2	36	96.8	21.5	71	159.8	65	150	302
-16.6	2	35.6	2.7	37	98.6	22.2	72	161.8	71	160	320
-16.1	3	37.4	3.3	38	100.4	22.7	73	163.4	76	170	338
-15.5	4	39.2	3.8	39	102.2	23.3	74	165.2	83	180	356
-15.0	5	41.0	4.4	40	104.0	23.8	75	167.0	88	190	374
-14.4	6	42.8	4.9	41	105.8	24.4	76	168.8	93	200	392
-13.9	7	44.6	5.5	42	107.6	25.0	77	170.6	121	250	482
-13.3	8	46.4	6.0	43	109.4	25.5	78	172.4	149	300	572
-12.7	9	48.2	6.6	44	111.2	26.2	79	174.2	177	350	662
-12.2	10	50.0	7.1	45	113.0	26.8	80	176.0	204	400	752
-11.6	11	51.8	7.7	46	114.8	27.3	81	177.8	232	450	842
-11.1	12	53.6	8.2	47	116.6	27.7	82	179.6	260	500	932
-10.5	13	55.4	8.8	48	118.4	28.2	83	181.4	288	550	1022
-10.0	14	57.2	9.3	49	120.2	28.8	84	183.2	315	600	1112
-9.4	15	59.0	9.9	50	122.0	29.3	85	185.0	343	650	1202
-8.8	16	61.8	10.4	51	123.8	29.9	86	186.8	371	700	1292
-8.3	17	63.6	11.1	52	125.6	30.4	87	188.6	399	750	1382
-7.7	18	65.4	11.5	53	127.4	31.0	88	190.4	426	800	1472
-7.2	19	67.2	12.1	54	129.2	31.5	89	192.2	454	850	1562
-6.6	20	68.0	12.6	55	131.0	32.1	90	194.0	482	900	1652
-6.1	21	69.8	13.2	56	132.8	32.6	91	195.8	510	950	1742
-5.5	22	71.6	13.7	57	134.6	33.3	92	197.6	538	1000	1832
-5.0	23	73.4	14.3	58	136.4	33.8	93	199.4	538	1000	1832
-4.4	24	75.2	14.8	59	138.2	34.4	94	201.2	593	1100	2012
-3.9	25	77.0	15.6	60	140.0	34.9	95	203.0	648	1200	2192
-3.3	26	78.8	16.1	61	141.8	35.5	96	204.8	704	1300	2372
-2.8	27	80.6	16.8	62	143.6	36.1	97	206.6	760	1400	2552
-2.2	28	82.4	17.1	63	145.4	36.6	98	208.4	815	1500	2732

KLUEBER LUBRICANT FOR SEALS

■ WHAT IS NOK KLUEBER

NOK KLUEBER CO., LTD. is a joint venture company between NOK and KLUEBER LUBRICATION CO. with a hundred-years of history as a special lubricant manufacturer.

NOK KLUEBER CO., LTD. is prepared to meet all customers' needs in the broad industrial field, such as high and low temperature, high speed, high load and long life with its abundant knowledge regarding lubrication, especially for needs under severe conditions.

■ Types of NOK KLUEBER lubricants

1. General purpose
Roller bearings, sliding bearings, chains, gears, valves, etc.
2. Lubricants for special applications
For oxygen, vacuum, radioactivity, sliding faces food machinery, textile machinery, various conveyors and so on.
3. Other special lubricants
Fluorene base lubricants, silicone oil type lubricant, special release agent, anticorrosive agent, lubricant for seals.

■ Features of NOK KLUEBER lubricants

1. For extreme high temperature and for cryogenic applications
Liquid lubrication : $-70 \sim 280^{\circ}\text{C}$
Dry lubrication : $1,200^{\circ}\text{C}$
2. High speed characteristic
Dm.N value: 1,500,000
3. High load characteristic
Load characteristics 24 times over general lithium base grease.
4. Long life characteristic
Actual durability record of 12,000 hours at the temperature of use at 200°C .
5. Resistance to external effects
Superior resistance to water, steam, sea water, acid, alkali and many other chemicals.
6. Effects on construction material
No deterioration on rubber, plastic, paint, etc.

NOK KLUEBER LUBRICANT FOR SEALS

NOK KLUEBER LUBRICANT FOR SEALS

Use	Lubricant	Effects upon rubber ^(Note 1)						Temperature range (°C)	Treatment (NLGI)	Water resistance	Application	Features
		Nitrile rubber	Acrylic rubber	Silicone rubber	Fluoro rubber	Chloroprene rubber	Ethylene Propylene rubber					
Normal condition For general seals	SEALUB S1	○	○	○	○	○	×	-30~120	2 (Soft)	Good	Automobile, construction	General purpose lubricant for rubber
	SYNTHESO PRO AM2	○	○	○	○	○	○	-40~150	2 (Soft)	Good		Less swelling of rubber than SEALUB S1
Extreme temperature and high speed For special seals	SEALUB S14	○	○	○	○	○	×	-60~160	2 (Soft)	Very good	Mixer, rice cake maker, water purifier, etc.	Applicable to wide range of temperatures from extremely low to high temperature
	MONTROP PLUS DR	○	○	○	○	○	×	-5~110	4 (Hard)	Very good		No taste, no smell, no harm. Resistant to water, boiling water, steam, detergent, less than 10% solution of hydrochloric acid, sulfuric acid and nitric acid.
	UNISLON L252L	○	○	×	○	○	○	-50~200	3 (Middle)			Except a certain fluorine based product, stable to general chemicals, gas and solvent.
High temperature, chemicals and vacuum application	BARRIERTA L552	○	○	○	○	○	○	-35~260	2 (Soft)	Good	Automobile, chemical plant equipment, vacuum machine, etc.	

Note 1: Compatibility

○ : Resistant

× : Not resistant

(Effects on rubber being of average evaluation, kindly check, prior to usage, if the lubricant to be used is suitable for the required using conditions.)

LINE-UP OF NOK PRODUCTS

Sealing products

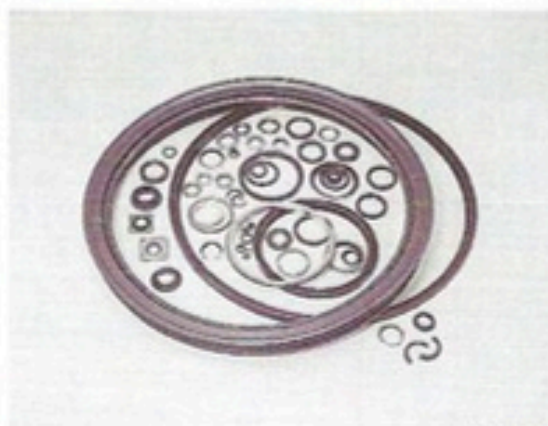

- Oil seals
- Magnetic fluid seals
"MAGNEBARRIER"
- Packings
- O-rings
- Mechanical seals
- Segment seals
- Metal gaskets "SOFTMETAL"
- Static metal packings
- Perfluoroelastomer "KALREZ"
- Seal washers

Oil seals

Industrial rubber & resin products



- Synthetic rubber material
- Polyurethane rubber
"IRON RUBBER" products
- Polyurethane rubber
"IRON RUBBER" belts
- Traffic sign boards and equipments
- Engineering plastic product
- Phenolic molding material

Polyurethane rubber "IRON RUBBER" products

Vibration damping Sound isolator, Absorber



- Anti-vibration products

Anti-vibration rubber

Hydraulic & air compressors



- Bradder type accumulators
- Small size Prada type accumulators
"Minilator"
- Piston type accumulators
- Small size spherical accumulators
"MU TYPE"
- Expansion tanks
- Air compressors

Bradder type accumulators

Plant equipment



Metal bellows (Welding bellows)

- Metal bellows
- Couplings
- Bellows valves

Electronics products



Flexible circuits

- Flexible circuit
- Multi-layer PCB "FLEXBOARD"
- Bus system
- Panel keyboard

Optoelectronics products

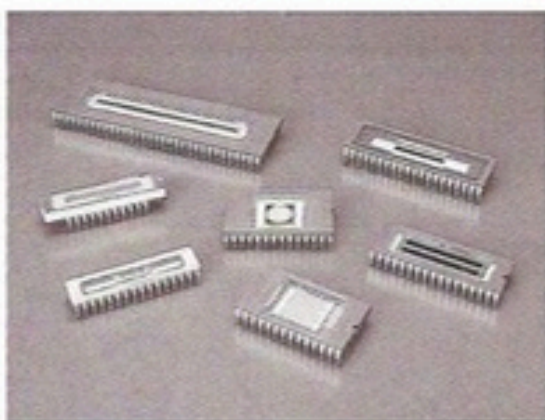

Image sensor

- Optoelectronics products
 - Image sensors
 - Ultra-red detectors
 - Photo diode
 - High output semi-conductor laser
 - Solid state camera
 - Image processing board "Max Video 20"

Industrial function parts & special parts

- Solenoids
- Actuators
- Suction control valves
- Various types of valves
- Potentiometer
- Oil water separators, impurity filters "LEIKAFILTER SEPARATOR"
- Lead valves
- High molecule hollow membrane modules
- Wear resistant structure material
- Special lubricant



Special lubricant

- Fluorine base water repellent & oil repellent agents "NOXGUARD"
- Fluorine base coating material "GLEITPAN"
- Oil-less bearing "LUBLESS"
- Adapters for cable breaking "SY JOINT"
- Carbon fiber compound carbon
- Electric contact points & discharge processing electrodes "ELMET"
- Compressor valves
- Recoil starters

©NOK CORPORATION Printed in Japan

Overseas Sales & Marketing Department Sales & Marketing Division
1-12-15 Shiba Daimon Minato-ku, Tokyo, Japan. Zipcord 105-8585.

The contents is subject to change without notice.

All compatibility data, application information, design & material information and technical data in this catalogue are compiled as a reference material to make a basic packing selection.
A selected standard design from this catalogue may not conform to the actual use of an application, due to unknown factors in the application.
Please confirm the actual compatibility of a selected product with your application before using it.

