

Many customers choose COPAL's potentiometers, which make use of the Company's original development and precision processing technologies.

This catalog is designed to help you make efficient selection of models when choosing from the Company's potentiometer products.

There are two basic methods, such as contact and contact-less method in COPAL's potentiometers.

The contact method is classified into conductive plastic resistor, and cermet resistor potentiometers depending on the resistor element used. Available models are single turn, multiturn, and linear types.

Our wirewound potentiometers make use of precision wire winding technology to achieve low noise and long life. Conductive plastic and cermet potentiometers use smooth coating resistors, providing essentially infinite resolution and long life. Contactless potentiometers are expected much longer life than contact method.

Our potentiometers are used in various industrial equipment (industrial robots, injection molding machines, bank's automatic teller machine), transportation equipment, computer peripheral devices, measuring instruments, and others for positioning and angle sensors, as well as for manual setting in communications equipment and measuring instruments.

CONTACT METHOD TYPE

Potentiometers are displacement sensors that produce electrical output (voltage) in proportion to the mechanical displacement.

They are basically composed of a resistor and a wiper (brush), with the mechanical displacement of the resistor relative to the wiper being accurately converted into electrical voltage output. A voltage is applied to both ends of the resistor, and the wiper is moved. The displacement is measured by the voltage between one terminal of the resistor and the wiper.

Looking at the component structurally, we can see the following: (Fig. 1)

Further, the following formulas apply to the voltage output.

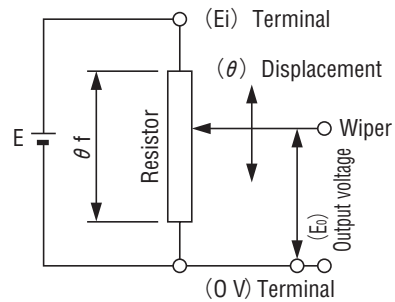

Fig. 1 Schematics diagrams

Effective electrical angle (Length): θf

Input voltage: E_i

Displacement (Length, Angle): θ

Output voltage: E_o

Linear output
$$\frac{E_o}{E_i} = \frac{\theta}{\theta_f} \quad (0 \leq \theta \leq \theta_f)$$

OPTICAL CONTACTLESS TYPE

Optical contactless potentiometers shall detect rotational angle at time of shaft rotation by positioning sensor which photo-electrically transfers the displacement of light transmitted through spiral slit that is placed between luminous element and positioning sensor.

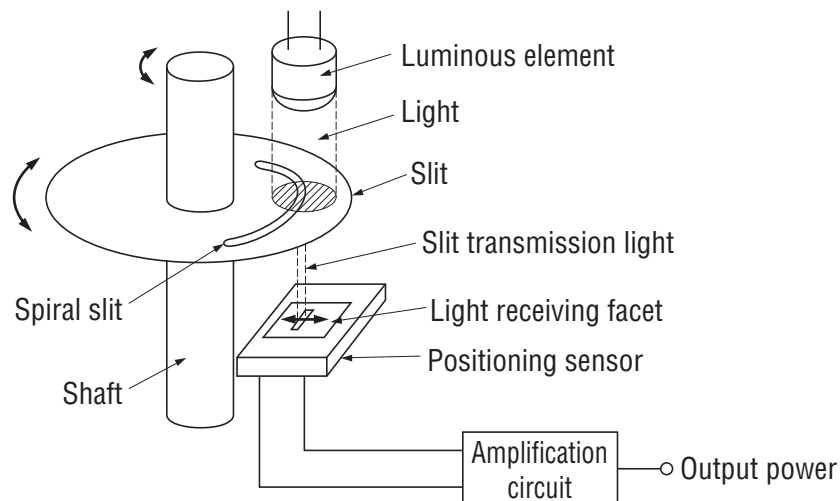

OPERATING PRINCIPLES

POTENTIOMETERS

CONTACT CONSTRUCTION AND OUTPUT TYPE

Wiper for wirewound type

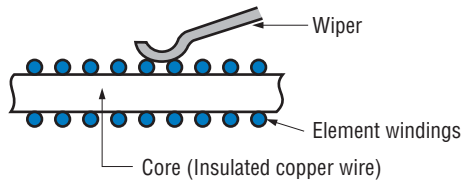

Wiper for conductive plastic type

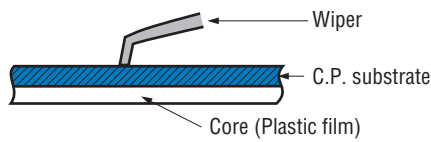

Wiper for cermet type

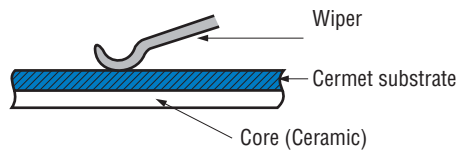

Resolution of wirewound type

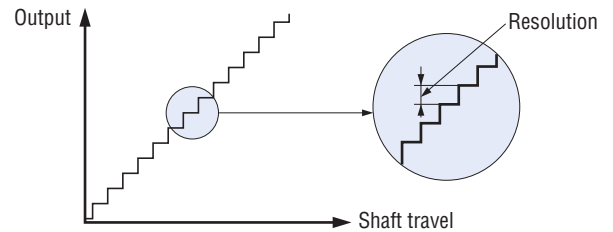

Resolution of conductive plastic, cermet type

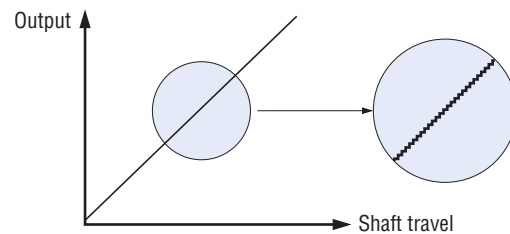

MODELS

<Wirewound type>

Precision wire winding technology has been used to achieve low noise and long life. Wirewound types include the single turn J series for use in servo drives and the multiturn M series for use in setting.

<Conductive plastic type>

Special film resistors and original contact construction provide long life, with degradation that is theoretically infinitely small.

Conductive plastic types include single turn types and linear types, both for use in servo drives.

<Cermet type>

The use of cermet resistors allows low price. The degradation is theoretically infinitely small. Cermet types are single turn for use in servo drives and for setting.

<Optical contactless type>

Contactless configuration offers much longer life and lower noise compared with the conventional contact method.

<Turns counting dials>

Turns counting dials come in analog type and can be used in conjunction with the multiturn M series potentiometers.

POTENTIOMETERS

APPLICATIONS

● Safety system for power shovel

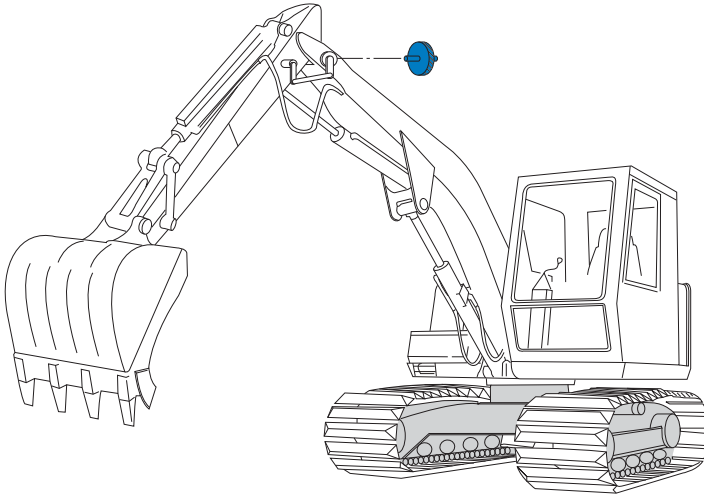

● For scales

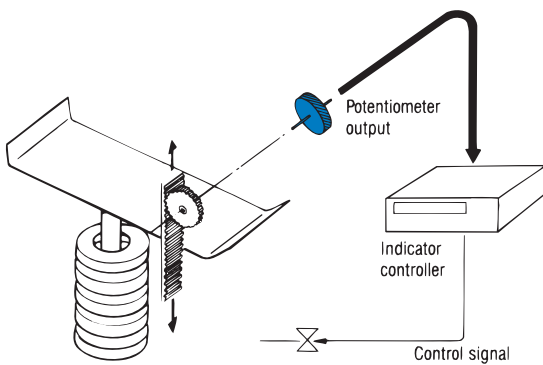

● For drafting machines and NC machines

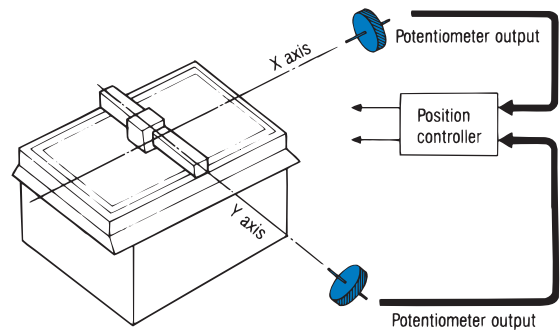

● For level control

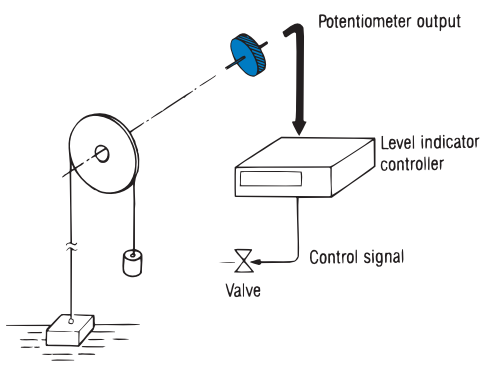

● For arm angle detection for cranes

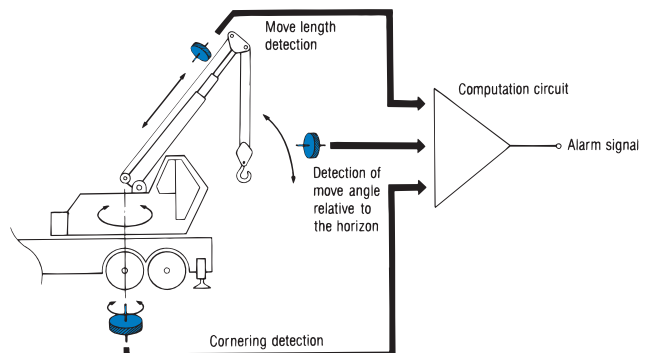

APPLICATIONS

POTENTIOMETERS

● Pen drive control of chart recorders

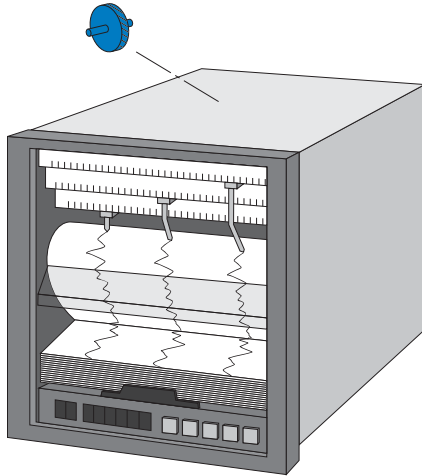

● Tension control of tension devices

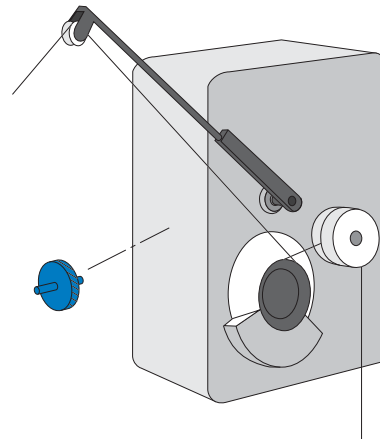

● Analog comparator setting

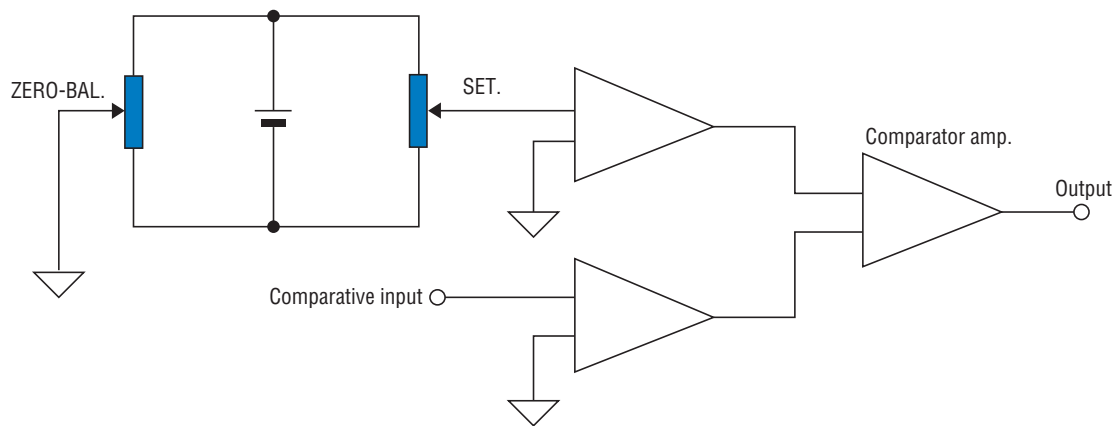

● Standard voltage generator setting

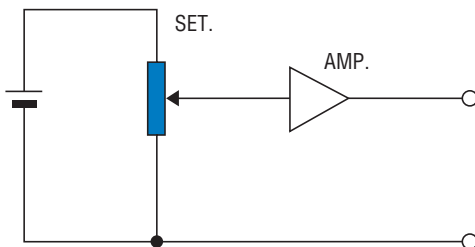

POTENTIOMETERS **NON-STANDARD VERSIONS**

Special specification items are possible. From a cost and delivery standpoint, however, it is better to use standard catalog items, so sufficient consideration should be given at the design stage. The following are some examples of special specification items.

- resistor, wiper unit



- Water proof potentiometer for construction machine



IP67

POTENTIOMETERS

ENVIRONMENTAL TEST

Series	J series	
Test item	Test conditions	Specifications
Temperature cycle	Performed 5 cycles 	1. Change in total resistance of less than 5 %. 2. No mechanical damage. Doing 5 cycles.
Resistor temperature characteristics	With 25 °C as a standard, the resistance was measured after 30 to 40 min in a constant tem-perature chamber of 0, - 25, - 55, 50 and 80 °C and the tem-perature coefficient to 25 °C was taken in each case.	Under the test temperature range, a resistance temperature coefficient of less than ± 50 ppm/°C (0.005 %/°C)
Rotational life	The shafts are rotated at 90 % effective electrical angle with no load at room temperature. (Refer to STANDARD SPECIFICATIONS)	1. Change in total resistance of less than 5 %. 2. More than 1.5 times of rated independent linearity. 3. Peak noise less than 50 Ω. 4. Less than 1.5 times rated torque.
Low temp. operation	The wiper output is set at about 40 %, and testing performed under the above conditions. 	1. Change in total resistance of less than 5 %. 2. Less than double rated torque. 3. No electrical or mechanical connection problem.
Low temp. exposure	After testing under the above conditions, the device is left at room temperature for 2 h. 	1. Change in total resistance of less than 5 %. 2. No mechanical damage.
High temp. exposure	The device is left at 85 °C for 1000 h.	Same as the low temp. exposure
Shock	Shocks of 981 m/s ² {100 G}/6 ms are applied from 6 directions, including directions to pull the wiper away from the resistor, with each shock being applied 3 times (total of 18 times). The shaft is fixed.	1. No mechanical damage. 2. No momentary loss of continuity.
High frequency vibration	Amplitude: 1.52 mm (10 ~ 70 Hz) Acceleration: 147 m/s ² {15 G} (70 ~ 2000 Hz) Frequency: 10 ~ 2000 Hz. Scanning time: 10 ~ 2000 Hz, 10 min. Performed under the above conditions 12 times each (Total 36 times). Shaft is fixed.	1. Change in total resistance of less than 5 %. 2. No electrical loss of continuity or mechanical damage. 3. No momentary loss of continuity.
Humidity resistance	25 °C to 65 °C, Relative humidity 95 % Performed for 10 cycles, each cycle being 24 h.	1. Change in total resistance of less than 5 %. 2. Insulation resistance of more than 10 MΩ.
Salt spray	The device is placed in a chamber at 35 °C, relative humidity 95 ~ 99 % and subjected to a 5 % salt water mist for 96 h.	No signs of corrosion.
Terminal strength	Terminals are subjected to 9.81 N {1 kgf} pulling and pressing for 5 to 10 s.	No electrical or mechanical damage.

ENVIRONMENTAL TEST

POTENTIOMETERS

Series Test item	M series	
	Test conditions	Specifications
Temperature cycle	Upper test temperature limit is 85 °C, lower limit is -40 °C. Others are same as for J series.	Same as for J series.
Resistor temperature characteristics	Same as for J series, except that measurement temperatures are 0, -15, -40, 50, 75 and 85 °C.	Same as for J series.
Rotational life	The shafts are rotated at 95 % effective electrical angle with no load at room temperature. (Refer to STANDARD SPECIFICATIONS)	Same as J series. But peak noise of the M22L10 series is less than 200 Ω.
Low temp. operation	Same as for J series. But test temperature is -40 °C.	Same as for J series.
Low temp. exposure	Same as for J series. But test temperature is -40 °C.	1. 2. Same as for J series. 3. The independent linearity standard is less than 1.5 times.
High temp. exposure	Same as for J series.	Same as the low temp. exposure
Shock	Same as for J series.	Same as for J series.
High frequency vibration	Same as for J series.	Same as for J series.
Humidity resistance	Same as for J series.	1. 2. Same as for J series. 3. No mechanical damage.
Salt spray	Same as for J series.	Same as for J series.
Terminal strength	Same as for J series.	Same as for J series.

ENVIRONMENTAL TEST POTENTIOMETERS

Series Test item	JC series	
	Test conditions	Specifications
Temperature cycle	Upper test temperature limit is 85 °C, lower limit is – 40 °C. Others are same as for J series.	<ol style="list-style-type: none"> 1. Change in total resistance of less than 10 %. 2. No mechanical damage or damage to the element.
Resistor temperature characteristics	Same as for J series, but lower temperature limit is – 40 °C.	Less than ± 400 ppm/°C (0.04 %/°C)
Roational life	<p><Rotational life> Rotated under same conditions as for J series. (Refer to STANDARD SPECIFICATIONS)</p> <p><Dither life> Shafts are rotated for 50 h at room temperature without load at 60 ± 5 Hz in a range of $5 \pm 3^\circ$.</p>	<ol style="list-style-type: none"> 1. Change in total resistance of less than 10 %. 2. The independent linearity standard is less than 1.5 times. 3. Output smoothness standard is less than 1.5 times. 4. The rotational torque standard is less than 1.5 times.
Low temp. operation	Same as J series	<ol style="list-style-type: none"> 1. Change in total resistance of less than 10 %. 2. 3. are the same as for the J series.
Low temp. exposure	Same as J series	<ol style="list-style-type: none"> 1. Less than the change in the output ratio, the linearity tolerance, or 0.5 % whichever is smallest. 2. No mechanical damage or damage to the element.
High temp. exposure	Same as J series	Same as the low temp. exposure
Shock	Same as J series	Same as J series
High frequency vibration	Same as J series	<ol style="list-style-type: none"> 1. Change in total resistance of less than 2 %. 2. 3. are the same as for the J series.
Humidity resistance	Same as J series	Change in total resistance of less than 10 %.
Salt spray	Same as J series	Same as J series
Terminal strength	Same as J series	Same as J series

ENVIRONMENTAL TEST

POTENTIOMETERS

Series Test item	JP-30		JP-30B	
	Test conditions	Specifications	Test conditions	Specifications
Temperature cycle	5 cycles at – 65 to 85 °C.	<ol style="list-style-type: none"> 1. Change in total resistance of less than 1 %. 2. No mechanical damage. 	5 cycles at – 65 to 85 °C.	<ol style="list-style-type: none"> 1. Change in total resistance of less than 1 %. 2. No mechanical damage.
Resistor temperature characteristics	Same as for the J series, except that the lower temperature limit is – 55 °C, and the upper temperature limit is 85 °C.	<ol style="list-style-type: none"> 1. $\pm 150 \cdot 10^{-6}/^{\circ}\text{C}$ Less than (0.015 %/°C) 	Same as for the J series, except that the lower temperature limit is – 55 °C, and the upper temperature limit is 85 °C.	<ol style="list-style-type: none"> 1. $\pm 150 \cdot 10^{-6}/^{\circ}\text{C}$ Less than (0.015 %/°C)
Rotational life	Shafts are rotated at room temp. no load at 80 r/min for 3 million revolutions (10000 revolutions in reverse).	<ol style="list-style-type: none"> 1. Change in total resistance of less than 5 %. 2. The independent linearity standard is less than 2 times of standard value. 3. Rotation noise at 4 r/min is less than 2 times. 4. Rotational torque Less than 1.5 times of standard value 	Shafts are rotated at room temp. no load at 80 r/min with an effective electrical angle of about 90 ° for 100000 cycles.	<ol style="list-style-type: none"> 1. Change in total resistance of less than 5 %. 2. The independent linearity standard is less than 2 times of standard value. 3. Rotation noise at 4 r/min is less than 2 times. 4. Rotational torque Less than 1.5 times of standard value
Low temp. operation	– 65 °C for 3 h	<ol style="list-style-type: none"> 1. Change in total resistance of less than 1 %. 2. No mechanical damage. 	– 65 °C for 3 h	<ol style="list-style-type: none"> 1. Change in total resistance of less than 1 %. 2. No mechanical damage.
Low temp. exposure	– 65 °C for 24 h	<ol style="list-style-type: none"> 1. Change in total resistance of less than 1 %. 2. No mechanical damage. 	– 65 °C for 24 h	<ol style="list-style-type: none"> 1. Change in total resistance of less than 1 %. 2. No mechanical damage.

ENVIRONMENTAL TEST POTENTIOMETERS

Series Test item	JP-30		JP-30B	
	Test conditions	Specifications	Test conditions	Specifications
High temp. exposure	85 °C for 1000 h	1. Change in total resistance is less than 2 %. 2. No mechanical damage.	85 °C for 1000 h	1. Change in total resistance is less than 2 %. 2. No mechanical damage.
Shock	3 times in 6 directions at 490 m/s ² {50 G}, 11 ms. Same as J series for other specifications.	1. No mechanical or electrical damage. 2. No momentary loss of continuity.	3 times in 6 directions at 490 m/s ² {50 G}, 11 ms. Same as J series for other specifications.	1. No mechanical or electrical damage. 2. No momentary loss of continuity.
High frequency vibration	147 m/s ² {15 G} or 1.52 mm amplitude, 70 ~ 2000 Hz. Same as J series for other specifications.	1. Change in total resistance of less than 2 %. 2. No mechanical damage	147 m/s ² {15 G} or 1.52 mm amplitude, 70 ~ 2000 Hz. Same as J series for other specifications.	1. Change in total resistance of less than 2 %. 2. No mechanical damage
Humidity resistance	Same as J series	1. Change in total resistance of less than 2 %. 2. Insulation resistance over 10 MΩ.	Same as J series	1. Change in total resistance of less than 2 %. 2. Insulation resistance over 10 MΩ.
Terminal strength	Tensile strength: 8.89 N {0.907 kgf}	No mechanical damage.	Tensile strength: 8.89 N {0.907 kgf}	No mechanical damage.

POTENTIOMETERS

HANDLING NOTES

- The potentiometers are precisely assembled and calibrated both electrically and mechanically, so sufficient care should be taken when handling.
- Do not attempt to modify or disassemble the potentiometers. In particular, pinholing or cutting the shaft will result in degraded performance and should be absolutely avoided.
- When using as a rheostat (partial load), make sure that excess current is not applied.
- When storing regardless for long or short periods of time, avoid high temperature and humidity as well as mechanical vibration and shock.
- To make effective use of the potentiometer's linearity, design that reflects the loading error described in the explanation of major terminology is important. If high input impedance cannot be achieved for the circuit, the Company can design and manufacture potentiometers that take this loading error into terminology.

- When checking the potentiometer's resistance of performing zero calibration, avoid using battery ohm meters. There is a possibility of damage of wiring or to the resistor.
- Perform soldering of the terminals at 350 °C for no more three seconds, and avoid applying excess heat. Also, avoid applying outside force to the terminals.
- In case of using multiturn potentiometers, when rotating the shaft to the mechanical limit, apply torque below the strength of the stopper. Also, give due consideration to thrust and radial loading.

● Apply only minute currents to the potentiometer's wiper

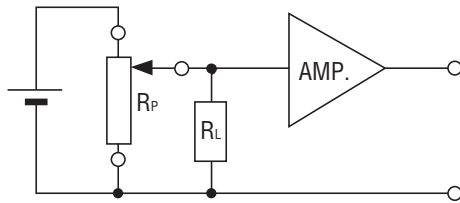

Attach to a high input impedance amplifier to create conditions where $R_P \ll R_L$

※ The diagram at right shows the loading error based on the ratio of R_P to R_L .
Select an equivalent load resistor (R_L) several hundred times the resistance value of the potentiometer.

● Loading error

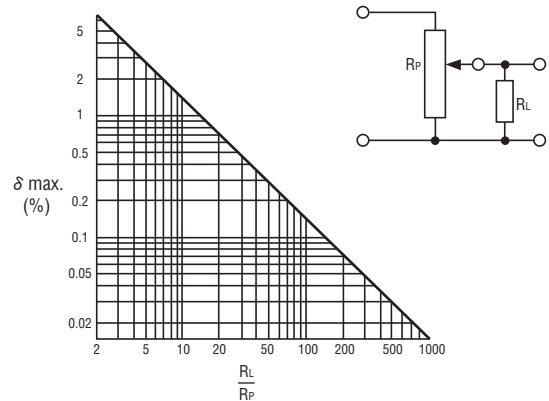

When resistance R_L is applied to the output terminal of the potentiometer, the linearity of the potentiometer is decreased by a maximum of the value shown in the following equation.

$$\delta \text{ max.} \doteq \frac{15R_P}{R_L} (\%)$$

- $\delta \text{ max.}$: Maximum change in linearity due to load resistor
- R_P : Total resistance value of potentiometer
- R_L : Load resistance value

■ RESOLUTION

The output ratio for wirewound potentiometers shows the smallest value of change.

● Theoretical degradation

The formula for theoretical degradation in wirewound potentiometers is shown below.

$$\text{Theoretical degradation} = \frac{1}{N} \times 100 (\%)$$

N: The total number of windings within the effective electrical angle.

● Angle degradation

The angle degradation shows the ratio (percentage) of the angle α needed to reduce the output voltage one step to the total electrical angle.

$$\text{Angle degradation} = \frac{\alpha}{\ell} \times 100 (\%)$$

α : Theoretical degradation angle
 ℓ : Effective electrical angle

● Voltage degradation

This shows the ratio (percentage) of the smallest output voltage to the voltage between the terminals (applied voltage).

$$\text{Voltage degradation} = \frac{e}{E} \times 100 (\%)$$

E: Voltage between the terminals
 e: Smallest degradation voltage

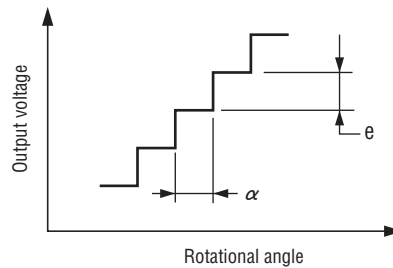

GLOSSARY

POTENTIOMETERS

■ END RESISTANCE AND ABSOLUTE MINIMUM RESISTANCE

This is the resistance caused by the relation of the effective electrical angle and the mechanical rotation angle.

● Effective electrical angle < Mechanical angle

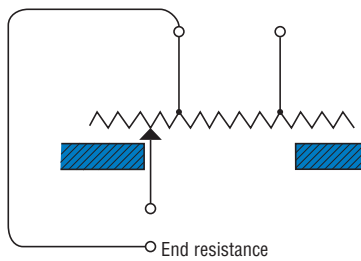

● Effective electrical angle > Mechanical angle

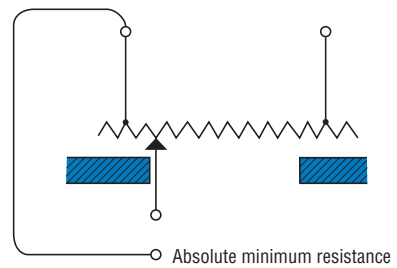

■ LINEARITY

Linearity is the deviation of the output voltage from the output voltage reference line from the rotation angle. There are four ways to choose the reference line. These include independent linearity, absolute linearity, terminal linearity, and zero reference linearity.

● Independent linearity

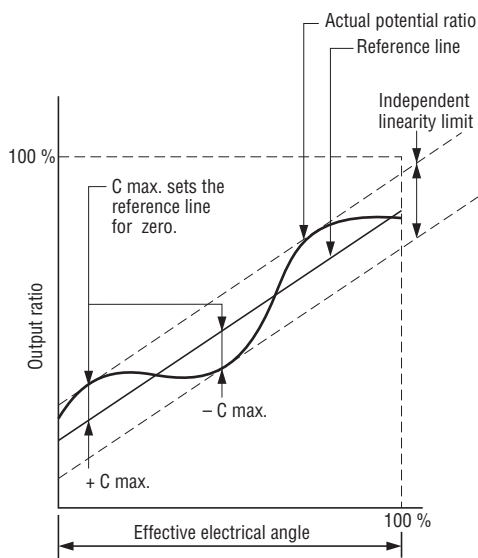

● Absolute linearity

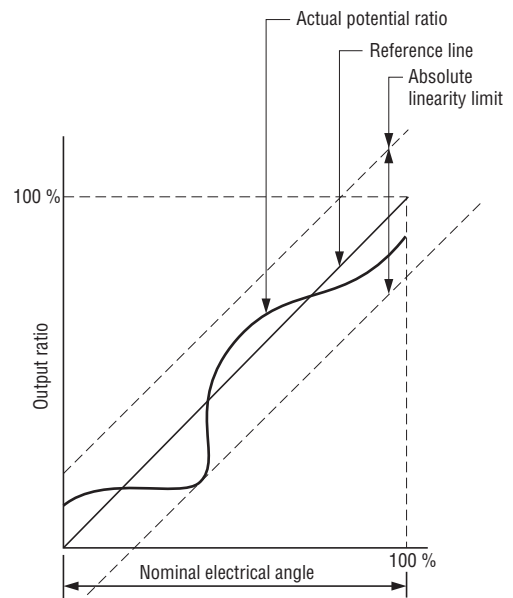

LOOKING AT ACTUAL DATA FROM INDEPENDENT LINEARITY

Unless otherwise specified, the linearity of our potentiometers is based on the independent linearity. The measurement of the linearity is made by comparing the actual output from the potentiometer and the computer-generated theoretical reference output.

The independent linearity is defined as shown below.

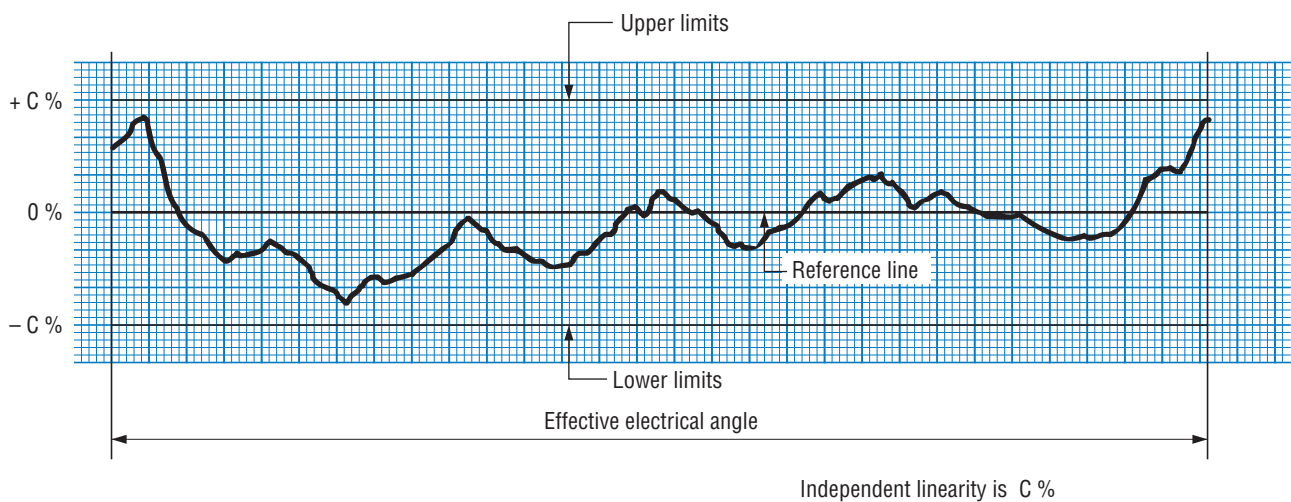

OUTPUT SMOOTHNESS

The output smoothness represents output stability of conductive plastic potentiometers when the shaft is rotated and is expressed by the ratio (percentage) of the output voltage variation to the input voltage. The measuring circuit is as shown below.

$$\text{Output smoothness} = \frac{\text{Output voltage variation (e)}}{\text{Input voltage (E)}} \times 100 (\%)$$

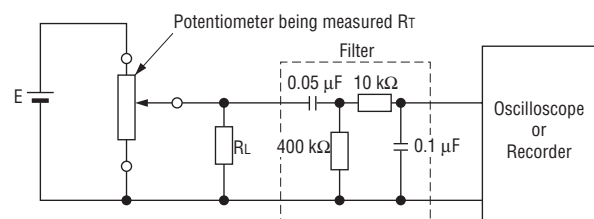
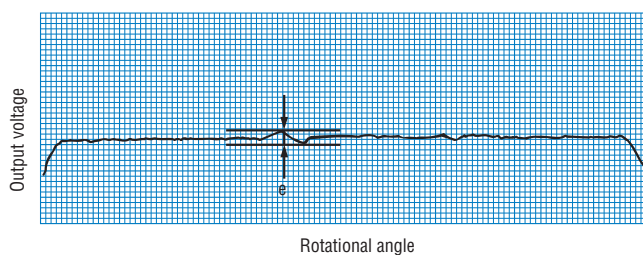

Filter: MIL-R-39023

Resistance load $R_L : R_L = R_T \nabla 100$

Rotational speed : 4 min^{-1}

GLOSSARY

POTENTIOMETERS

EFFECTIVE ELECTRICAL ANGLE AND MECHANICAL ANGLE

A: This is the effective electrical angle and shows the actual change in output voltage as the volume of shaft movement.

C: This is the dead angle and shows the portion where the wiper and the resistor are completely electrically disconnected.

B: This is the ineffective angle and shows the portion where electricity is conducting, but there is no actual change in output voltage.

D: This is the mechanical rotation angle and shows the movement of the shaft. When there is no stopper, this angle is 360°.

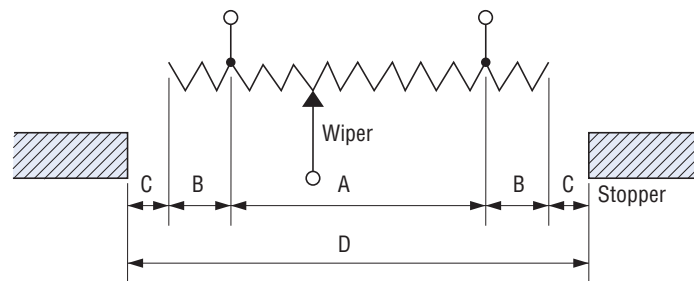

ROTATIONAL NOISE

This is equivalent noise resistance that occurs when the potentiometer's shaft is rotated and is also called peak noise.

This test method is specified in MIL-R-12934F, and the equivalent noise resistance here is calculated as follows:

$$\text{Rotational noise} = \frac{E_p}{0.001} \ (\Omega)$$

E_p : The peak noise voltage (V) displayed on the oscilloscope.

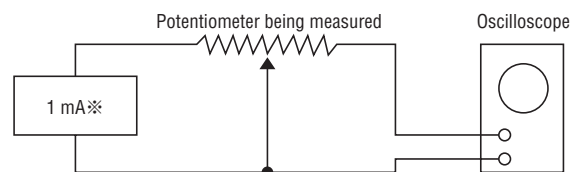

Shaft rotation speed: 4 min⁻¹
Oscilloscope frequency band width: DC ~ 50 kHz over

※ DC1 mA constant current power supply

LOADING ERROR

The output accuracy of a potentiometer is adversely affected by the input impedance of the next stage (or the load of the potentiometer).

This is called "loading error" .

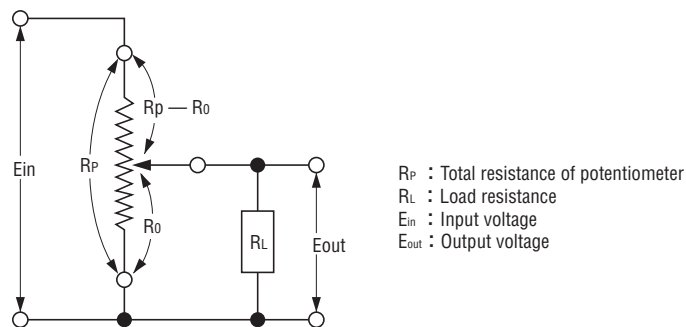

In the above diagram, if the load impedance is infinitely large, the output voltage ratio of the potentiometer will be proportional to the resistance change ratio.

$$\frac{E_{out}}{E_{in}} = \frac{R_o}{R_p}$$

However, if the load impedance is limited, the output voltage ratio is shown as follows.

$$\frac{E_{out}}{E_{in}} = \frac{R_o}{R_p + (R_p - R_o) \frac{R_o}{R_L}}$$

Loading error is shown by the following formula:

$$\delta = \frac{\left(1 - \frac{R_o}{R_p}\right) \left(\frac{R_o}{R_p}\right)^2}{\frac{R_L}{R_p} + \left(1 - \frac{R_o}{R_p}\right) \frac{R_o}{R_p}} \times 100 (\%)$$

GLOSSARY

POTENTIOMETERS

PROTECTION GRADE

• Protection grade applies to the environment of potentiometer use.

• The Protection grade aims at water protection. For the oil or various types of liquid, please be reminded that the degree of protection is different.

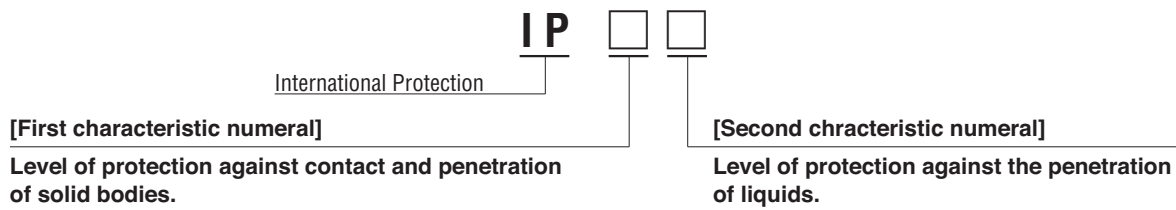

Grade	Degree of protection	
0		No protection
1		Protected against solid foreign objects such as hands of \varnothing 50 mm and greater.
2		Protected against solid foreign objects such as finger of \varnothing 12.5 mm and greater.
3		Protected against solid foreign objects such as tools or wires of (\varnothing or thickness of) 2.5mm and greater.
4		Protected against solid foreign objects such as tools or wires of (\varnothing or thickness of) 2.5mm and greater.
5		Protected against such dust as damages the equipment operation.
6		Dust-tight

[Related standards]
 IEC (The International Electrotechnical Commission) standard
 IEC 60529
 Degrees of protection provided by enclosures

JIS (Japanese Industrial Standards) standards JIC-C-0920
 Test to prove protection against ingress of water and degree of protection

Grade	Category	Degree of protection	
0			No protection
1	Drip-proof I type		Protected against vertically falling water drops.
2	Drip-proof II type		Protected against vertically falling water drops when enclosure is tilted up to 15°.
3	Rain-proof type		Protected against rainfall when enclosure is tilted up to 60°.
4	Splash-proof type		Protected against splashing water.
5	Water-jets-proof type		Protected against water jets.
6	Waterproof type		Protected against powerful water jets.
7	Watertight type		Protected against the effects of temporary immersion in water.
8	Underwater type		Protected against the effects of continuous immersion in water.

POTENTIOMETER INSTALLATION

Below installation method is available.

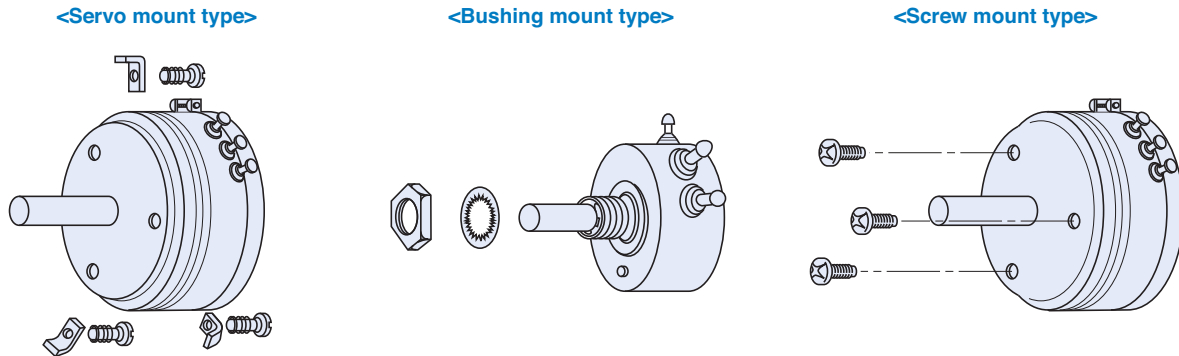

External dimensions for servo mount ratchet

(Unit: mm)

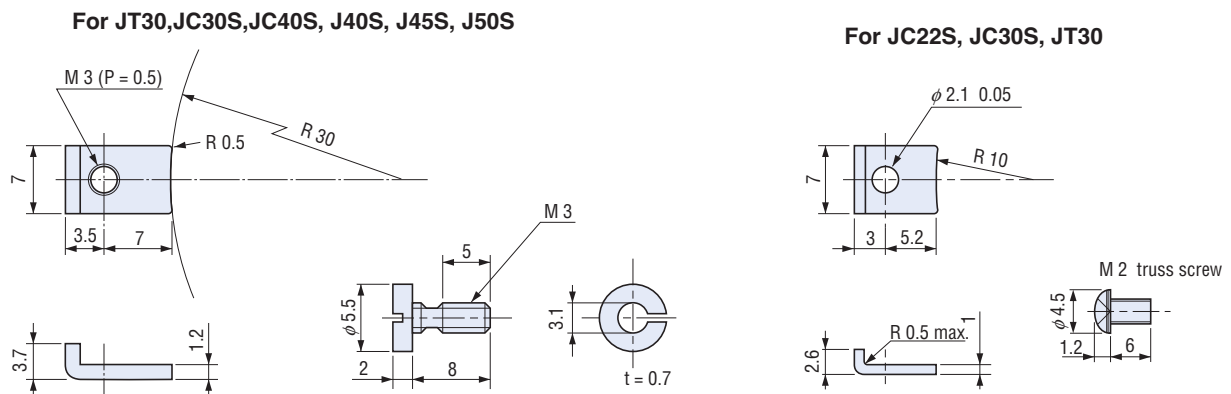

The ratchet for servo mounting can be provided upon request.

LIST OF INSTALLATION

Installation	Series name	J series	JC series	JP-30	JT series	MC series
Servo mount type		●	●		●	
Bushing mount type				●		●
Screw mount type		●	●		●	