

Type 600 Stainless Steel Ball Valves

Reduced bore, Uni-body design, Threaded ends

Features

- Blowout-proof stem
- Choice of threaded ends:
 - Rc threads to JIS B0203 (BS 21) (Fig. UTKM)
 - NPT threads to ASME B1.20.1 (Fig. AKUTKM)

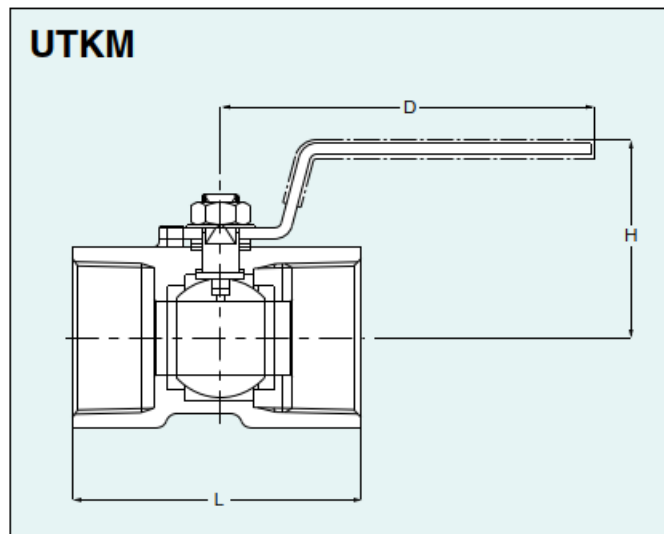

Dimensions of UTKM

Unit: mm

Nominal Size	NPS	1/4	3/8	1/2	3/4	1	1 1/4	1 1/2	2
	DN	8	10	15	20	25	32	40	50
Ball bore		4.5	6.8	9.2	12.5	16	20	24.5	32
L		39	44	56.5	59	71	78	83	100
H		31	36	41	44	48	54	65	72
D		60	70	85	85	100	100	125	125

Page 114 for Pressure-Temperature Ratings.

Standard Materials

Parts	Materials
Body	CF8M
Ball	CF8M/316
Stem	316
Seat	Glass filled PTFE
Gland packing	Reinforced PTFE
Handle	Plastic covered S.S.

End to end dimensions: KITZ standard

Valve operator

Lever operation
T-type handle as option