

Type 1000 Stainless Steel Ball Valves

Reduced bore, 3-piece body design, Threaded or socket welding ends

Features

- Blowout-proof stem
- Swing-away body for maintenance ease
- Choice of threaded ends:
 - Rc threads to JIS B0203 (BS 21) (Fig. U3TZM)
 - NPT threads to ASME B1.20.1 (Fig. AKU3TZM)
 - Socket welding ends to JIS B2316 (BS 5351)/ ASME B16.11 (Fig. SWU3TZM)
 - Socket welding ends to ASME B16.11 (Fig. AWU3TZM)

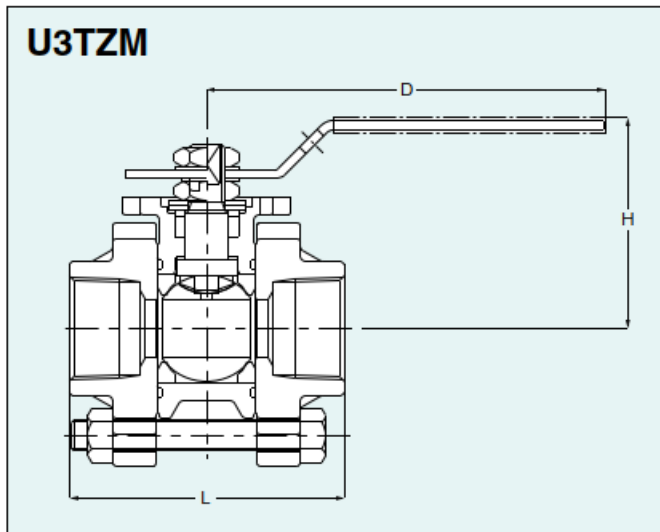

Dimensions of U3TZM

Unit: mm

Nominal Size	NPS	1/2	3/4	1	1 1/4	1 1/2	2
	DN	15	20	25	32	40	50
Ball bore		10	14	19	24	30	38
L		63	71	90	103	110	127
H		48	60	69	83	88	104
D		120	130	130	150	150	180

Page 114 for Pressure-Temperature Ratings.

Standard Materials

Parts	Materials
Body	CF8M
Body cap	CF8M
Ball	316 or CF8M
Stem	316
Seat	HYPATITE® PTFE
Gland packing	PTFE
Gasket	PTFE
Handle	Plastic covered S.S.

End to end dimensions: KITZ standard

Valve operator

Lever operation
Oval handle as option

Note

· Use U3TZFM for NPS 1/4 and 3/8.