

Climate
Control

IMI Pneumatex

Transfero TV Connect



**Pressure maintenance system with pumps and
integrated cyclonic vacuum degassing**

For heating systems up to 8 MW and cooling systems
up to 13 MW

Transfero TV Connect

Transfero TV Connect is a precision pressure maintenance device for heating and solar systems up to 8 MW, and chilled water systems up to 13 MW. Its use is particularly recommended where high performance, compact design and precision are required.

The **BrainCube Connect** control panel allows a new level of connectivity, enabling communication with the BMS system, other BrainCubes as well as remote operation of the pressurisation system through live viewing.

Key features

2 in 1

The only pressurisation unit with integrated cyclonic vacuum degassing

Higher Efficiency Cyclonic vacuum degassing

At least 50% higher efficiency than most other vacuum degassing systems.

Easy Commissioning, Remote Access and Trouble-shooting

Automatic calibration and integrated standard connections to our IMI Webserver and to BMS.



Technical description – Control unit TecBox

Applications:

Closed heating, solar and chilled water systems.

For systems according to EN 12828, SWKI HE301-01, solar systems according to EN 12976, ENV 12977 with on-site excess temperature protection in case of power outage.

Media:

Non-aggressive and non-toxic system media.
Ethylene or propylene glycol-based antifreeze up to 50%.

Pressure:

Min. admissible pressure, PSmin: -1 bar
Max. admissible pressure, PS: see Articles

Temperature:

Max. admissible temperature, t_{Smax} : 90°C
Min. admissible temperature, t_{Smin} : 0°C
Max. admissible ambient temperature, t_{Amax} : 40°C
Min. admissible ambient temperature, t_{Amin} : 5°C

Accuracy:

Precision pressure maintenance $\pm 0,2$ bar.

Supply voltage:

1 x 230 V (-/+ 10 %), 50 Hz

Electrical connections:

1 plug socket (incl. counter plug) for supply voltage 230V (external fuses according power needs and local electrical norms)
4 potential free outputs (NO) for external alarm indication (230V max. 2A)
1 RS 485 In/Output
1 Ethernet RJ45 plug socket
1 USB Hub plug socket

Enclosure class:

IP54 according to EN 60529

Mechanical connections:

Sin1/Sin2: inlet from the system G3/4"
Sout: outlet to the system G3/4"
Swm: inlet water make-up G3/4"
Sv: connection of the vessel G1 1/4"

Material:

Metal components with medium contact: carbon steel, cast iron, stainless steel, AMETAL®, brass, gun metal.

Transportation and storage:

In frostless, dry places.

Standard:

Constructed according to MD 2006/42/EC, Annex II 1.A
EMC-D. 2014/30/EU

Technical description – Expansion vessels

Applications:

Only together with TecBox Control Unit.
See Applications under Technical description - TecBox Control Unit.

Media:

Non-aggressive and non-toxic system media.
Ethylene or propylene glycol-based antifreeze up to 50%.

Pressure:

Min. admissible pressure, PSmin: 0 bar
Max. admissible pressure, PS: 2 bar

Temperature:

Max. admissible temperature, t_{Smax} : 120 °C
Min. admissible temperature, t_{Smin} : -10 °C
Max. admissible bag temperature, t_{Bmax} : 70 °C
Min. admissible bag temperature, t_{Bmin} : 5 °C

Material:

Steel. Color beryllium.
Airproof butyl bag according to EN 13831.

Transportation and storage:

In frostless, dry places.

Standard:

Constructed according to PED 2014/68/EU.

Warranty:

Transfero TU, TU...E: 5-year warranty for the vessel.
Transfero TG, TG...E: 5-year warranty for the airproof butyl bag.

Function, Equipment, Features

Control unit BrainCube Connect

- BrainCube Connect control for an intelligent, fully automatic, safe system operation. Self-optimising with memory function.
- Resistive 3.5" TFT illuminated colour touch display. Web-based interface with remote control and live view. User-friendly, operation-orientated menu layout with slide and tap operation, step-by-step start up procedure guide and direct help in pop-up windows. Representation of all relevant parameters and operation status in plain text and/or graphical, multilingual.
- Standardised integrated connections (Ethernet, RS 485) to the IMI webserver and BMS (Modbus and IMI protocol).
- Software updates and data logging possible via USB connection.
- Data logging and system analysis, chronological message memory with prioritisation, remotely controllable with live view, periodical automatic self-test.
- High quality metal cover.
- Variable installation next to the primary vessel.

Pressure maintenance

- Dynaflex operation.
- Protected isolating valves to the system. 2 bar safety valve and ball valve for fast draining of primary vessel
- Precision pressure maintenance ± 0.2 bar

Vacuum Degassing

- About 1000 l/h flow capacity for system degassing.
- Vacusplit: Degassing programs for permanent operation with cyclonic technology. Gas under saturation of system water of nearly 100%. Eco automatic operation when no air is detected, savings on electricity consumption of the pump.
- Oxystop degassing: Direct degassing of make-up water. Significant oxygen reduction in the make-up water. Safely degasses both system and make-up water in a specially designed cyclone vessel (inside the Tecbox), with the advantage of low keeping temperature of the expansion vessel, without the need to insulate the vessel. Protects the system against corrosion.

Water make-up

- Fillsafe: water-make up monitoring and control with integrated contact water flow meter and solenoid valve.
- Connection for optional Pleno P BA4R/AB5(R) water make-up devices for tap water protection following EN 1717.
- Connection for optional water make-up devices can be used for external fluid tanks.
- Softsafe monitoring and control for an optional refill water treatment device.

Expansion vessels

- Bag can be vented at the top, condensate drain at the bottom.
- Sinus ring for upright assembly (TU, TU...E). Feet for upright assembly (TG, TG...E).
- Corrosion-protected internal coating for minimum bag wear (TG, TG...E).
- Airproof butyl bag (TU, TU...E, TG, TG...E), exchangeable (TG, TG...E).
- Endoscopic inspection opening for internal inspections (TU, TU...E). Two flange openings for internal inspections (TG, TG...E).

Calculation

Pressure maintenance for systems TAZ ≤ 100°C

Calculation following EN 12828, SWKI HE301-01 *).

For all special applications such as solar systems, district heating systems, systems with temperatures above 100°C or cooling systems with temperatures below 5°C please use HySelect software or contact us.

General equations

Vs	Water capacity of the system	Heating	Vs = vs · Q	vs Q	Specific water capacity, table 4 Installed heat capacity
			Vs= Known		System design, content calculation
		Cooling	Vs= Known		System design, content calculation
Ve	Expansion volume	EN 12828	Ve = e · (Vs+Vhs)	e, ehs	Expansion coefficient for ts _{max} , table 1
		Cooling	Ve = e · (Vs+Vhs)	e, ehs	Expansion coefficient for ts _{max} , table 1 ⁷⁾
		SWKI HE301-01 heating	Ve = e · Vs · X ¹⁾ + ehs · Vhs	e ehs	Expansion coefficient for (ts _{max} + tr)/2, table 1 Expansion coefficient for ts _{max} , table 1
		SWKI HE301-01 cooling	Ve = e · Vs · X ¹⁾ + ehs · Vhs	e, ehs	Expansion coefficient for ts _{max} , table 1 ⁷⁾
Vwr	Water reserve	EN 12828, cooling	Vwr ≥ 0,005 · Vs ≥ 3 L		
		SWKI HE301-01	Vwr is considered in Ve with the coefficient X		
p0	Minimum pressure ²⁾ Lower limit value for the pressure maintenance	EN 12828, cooling	p0 = Hst/10 + 0,2 bar ≥ pz	Hst	Static height Minimum required equipment pressure for pumps or boilers
		SWKI HE301-01	p0 = Hst/10 + 0,3 bar ≥ pz	pz	
pa	Initial pressure Lower threshold for an optimum pressure maintenance		pa ≥ p0 + 0,3 bar		
pe	Final pressure			psvs dpsvs _c	Response pressure safety valve system Closing pressure tolerance of the safety valve
		EN 12828	pe ≤ psvs - dpsvs_c	dpsvs _c = dpsvs _c =	0,5 bar for psvs ≤ 5 bar ⁴⁾ 0,1 · psvs for psvs > 5 bar ⁴⁾
		Cooling	pe ≤ psvs - dpsvs_c	dpsvs _c = dpsvs _c =	0,6 bar for psvs ≤ 3 bar ⁴⁾ 0,2 · psvs for psvs > 3 bar ⁴⁾
		SWKI HE301-01 heating	pe ≤ psvs/1,15 and pe ≤ psvs - 0,3 bar		psvs ⁴⁾
		SWKI HE301-01 cooling, solar, heat pump	pe ≤ psvs/1,3 and pe ≤ psvs - 0,6 bar		psvs ⁴⁾

Transfero

pe	Final pressure Upper threshold for an optimum pressure maintenance.		pe = pa + 0,4		
VN	Nominal volume of the expansion vessel ⁵⁾	EN 12828, cooling	VN ≥ (Ve + Vwr) · 1,1		
		SWKI HE301-01	VN ≥ Ve · 1,1		
TecBox			Q = f(Hst)	>> Quick selection Transfero	

1) Heating, Cooling, Solar: Q ≤ 10 kW: X = 3 | 10 kW < Q ≤ 150 kW: X = (87-0,3 · Q)/28 | Q > 150 kW: X = 1,5

Geothermal probe systems: X = 2,5

2) The formula for minimum pressure p0 applies to the installation of the pressure maintenance on the suction side of the circulation pump. In case of a pressure-side installation p0 is to be increased by the pump pressure Δp.

4) Safety valves must operate within these limits. Use component-tested and certified safety valves of type H and DGH for heating systems, type F and DGF for cooling, and type SOL and DGF for solar. For systems according to SWKI HE301-01, only safety valves of the approval type DGF and DGH may be used.

5) Please select a vessel which has an equal or higher nominal content.

7) Max. system standstill temperature, usually 40°C for cooling applications and geothermal probes with ground regeneration, 20°C for other geothermal probes

*) SWKI HE301-01: Valid for Switzerland

HySelect calculation software is based on an advanced calculation method and database. Results may vary.

Table 1: e expansion coefficient

t (TAZ, ts _{max} , tr, ts _{min}), °C	20	30	40	50	60	70	80	90	100	105	110
e Water = 0 °C	0,0016	0,0041	0,0077	0,0119	0,0169	0,0226	0,0288	0,0357	0,0433	0,0472	0,0513
e % weight MEG*											
30 % = -14,5 °C	0,0093	0,0129	0,0169	0,0224	0,0286	0,0352	0,0422	0,0497	0,0577	0,0620	0,0663
40 % = -23,9 °C	0,0144	0,0189	0,0240	0,0300	0,0363	0,0432	0,0505	0,0582	0,0663	0,0706	0,0750
50 % = -35,6 °C	0,0198	0,0251	0,0307	0,0370	0,0437	0,0507	0,0581	0,0660	0,0742	0,0786	0,0830
e % weight MPG**											
30 % = -12,9 °C	0,0151	0,0207	0,0267	0,0333	0,0401	0,0476	0,0554	0,0639	0,0727	0,0774	0,0823
40 % = -20,9 °C	0,0211	0,0272	0,0338	0,0408	0,0481	0,0561	0,0644	0,0731	0,0826	0,0873	0,0924
50 % = -33,2 °C	0,0288	0,0355	0,0425	0,0500	0,0577	0,0660	0,0747	0,0839	0,0935	0,0985	0,1036

Table 4: vs approx. water capacity * of central heatings referred to the installed heat capacity Q**

ts _{max} tr	°C	90 70	80 60	70 55	70 50	60 40	50 40	40 30	35 28
Radiators	vs liter/kW	14,0	16,5	20,1	20,6	27,9	36,6	-	-
Flat radiators	vs liter/kW	9,0	10,1	12,1	11,9	15,1	20,1	-	-
Convectors	vs liter/kW	6,5	7,0	8,4	7,9	9,6	13,4	-	-
Air handlers	vs liter/kW	5,8	6,1	7,2	6,6	7,6	10,8	-	-
Floor heating	vs liter/kW	10,3	11,4	13,3	13,1	15,8	20,3	29,1	37,8

*) MEG = Mono-Ethylene Glycol

**) MPG = Mono-Propylene Glycol

***) Water capacity = heat generator + distribution net + heat emitters

Table 6: DNe standard values for expansion pipes with Transfero TV_*

	DNe	Hst [m]	DNd	Hst [m]	DNe	Hst [m]	DNd	Hst [m]	DNe	Hst [m]	DNd	Hst [m]
	Length up to approx. 5 m				Length up to approx. 10 m				Length up to approx. 30 m			
TV_4.1 E	25	all	25	all	25	all	25	all	32	all	32	all
TV_4.1 EH	32	all	25	all	32	all	25	all	40	all	32	all
TV_4.2 EH	32	all	25	all	50 40	<13 ≥13	25	all	50	all	32	all
TV_6.1 E	25	all	25	all	25	all	25	all	32	all	32	all
TV_6.1 EH	32	all	25	all	40 32	<23 ≥23	25	all	50 40	<26 ≥26	32	all
TV_6.2 EH	50 40	<18 ≥18	25	all	50 40	<25 ≥25	25	all	65 50	<22 ≥22	32	all
TV_8.1 E	25	all	25	all	25	all	25	all	32	all	32	all
TV_8.1 EH	32	all	25	all	40 32	<24 ≥24	25	all	50 40	<28 ≥28	32	all
TV_8.2 EH	50 40	<27 ≥27	25	all	50 40	<34 ≥34	25	all	65 50	<30 ≥30	32	all
TV_10.1 E	25	all	25	all	25	all	25	all	32	all	32	all
TV_10.1 EH	40 32	<29 ≥29	25	all	40 32	<40 ≥40	25	all	50 40	<45 ≥45	32	all
TV_10.2 EH	50 40	<44 ≥44	25	all	50 40	<52 ≥52	25	all	65 50	<48 ≥48	32	all
TV_14.1 E	25	all	25	all	25	all	25	all	32	all	32	all
TV_14.1 EH	32	all	25	all	32	all	25	all	40 32	<80 ≥80	32	all
TV_14.2 EH	50 40	<61 ≥61	25	all	50 40	<80 ≥80	25	all	65 50	<70 ≥70	32	all

*)

For proper operation of the devices, the specified DNe values cannot fall below.

TV.1: 1 expansion pipe DNe, 1 connection pipe DNd due to degassing

TV.1 EH, TV.2 EH for tr < 5°C or tr > 70°C: 2 expansion pipes DNe, 1 connection pipe DNd due to degassing

TV.1 EH, TV.2 EH for 5°C ≤ tr ≤ 70°C: 1 expansion pipes DNe, 1 connection pipe DNd due to degassing

Table 7: DNet - Pipe dimension for the connection of an optional external tank

Length up to approx. 2 m	DNet	20
Length up to approx. 10 m	DNet	25
Length up to approx. 30 m	DNet	32

Temperatures

ts_{max}	Maximum system temperature Maximum temperature for the calculation of the volume expansion. For heating systems the dimensioned flow temperature at which a heating system is to be operated with the lowest outside temperature to be assumed (standard outside temperature according to EN 12828). For cooling systems the max. temperature that is achieved due to the operation mode or standstill, for solar systems the temperature up to which an evaporation is to be avoided.
ts_{min}	Lowest system temperature Lowest temperature for calculating expansion volumes. The lowest system temperature is equal to the freezing point. It is dependant on the percentage of antifreeze additives. For water without additives $ts_{min} = 0$.
tr	Return temperature Return temperature of the heating system with the lowest outside temperature to be assumed (standard outside temperature according to EN 12828).
TAZ	Safety temperature limiter Safety temperature controller Temperature limit Safety device according to EN 12828 for the temperature protection of heat generators. If the set temperature limit is exceeded the heating is turned off. Limiters are locked, controllers automatically release the heat supply if the set temperature falls short. Setting value for systems according to EN 12828 ≤ 110 °C.

Precision pressure maintenance

Transfero minimizes the pressure variations between p_a and p_e .
 Transfero $\pm 0,2$ bar

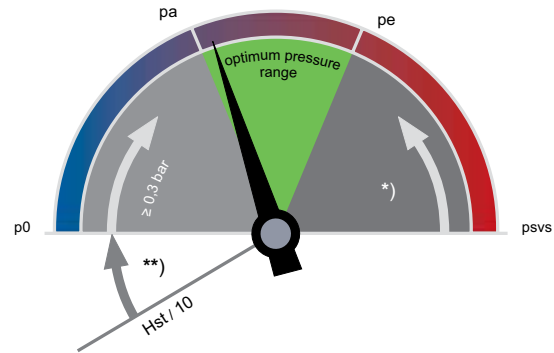

**)

EN 12828, Solar, Cooling: $\geq 0,2$ bar
 SWKI HE301-0: $\geq 0,3$ bar

*)

EN 12828: $\geq psvs \cdot 0,1 \geq 0,5$ bar
 Solar, Cooling: $\geq psvs \cdot 0,2 \geq 0,6$ bar
 SWKI HE301-01 Heating $\geq psvs \cdot (1-1/1,15) \geq 0,3$ bar
 SWKI HE301-01 Cooling, Solar, Heat Pumps $\geq psvs \cdot (1-1/1,3) \geq 0,6$ bar

p0 Minimum pressure

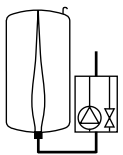

Transfero

p_0 and the switching points are calculated by the BrainCube.

pa Initial pressure

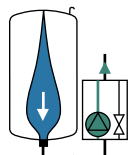

Transfero

If the system pressure is $< p_a$, the pump starts.
 $p_a = p_0 + 0,3$

pe Final pressure

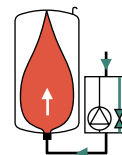

Transfero

If system pressure is $> p_e$, the relief valve opens.
 $p_e = p_a + 0,4$

Quick selection

Operation range dpu

Type

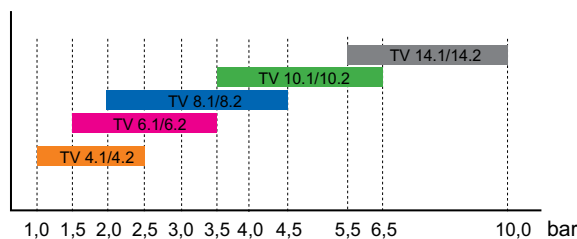

		TV_4	TV_6	TV_8	TV_10	TV_14
dpu min	bar	1	1,5	2	3,5	5,5
dpu max	bar	2,5	3,5	4,5	6,5	10

IMI Pneumatex cyclonic vacuum degassing - the technology

How does cyclonic vacuum degassing work?

In cyclonic vacuum degassing, part of the medium is passed to a special degassing tank where it is exposed to strong negative pressure. An orifice in the inlet pipe limits the flow rate of the water to less than what the pump is able to deliver. This releases the dissolved gases inside the container. The resulting fluid is milky in appearance because of the many tiny bubbles it contains. In conventional systems, the problem at this point is how to separate and expel these gas microbubbles from the medium. Various technologies are available, but none of them is particularly effective.

IMI Pneumatex has devised a solution using revolutionary cyclone technology. The patented Cyclone vacuum degassing technology quickly concentrates the tiny gas bubbles in the middle, where they rapidly form larger bubbles that are very easily removed from a second tank.

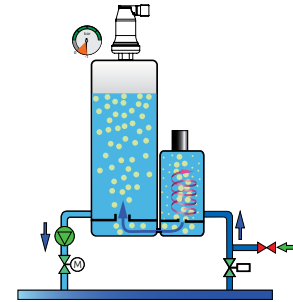

Cyclonic vacuum degassing in Transfero Connect

Cyclonic vacuum degassing technology allows for the use of compact degassing vessels that can be integrated into pump pressurisation systems as a simple and economical solution. This integration has led to the creation of the IMI Pneumatex Transfero TV/TVI Connect pump pressure maintenance system. During the degassing processes, a motorised ball valve between the expansion tank and the degassing vessels is permanently closed, opening only for the pressure-maintenance function. The sophisticated BrainCube Connect control system ensures that the pressurisation, vacuum degassing, water make-up and water treatment processes run smoothly and under constant monitoring.

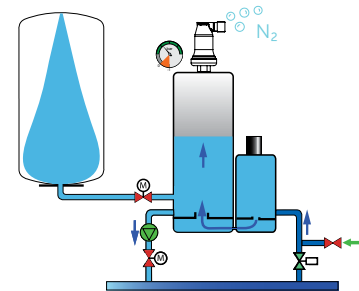

IMI Pneumatex cyclonic vacuum degassing - efficiency and measurements

To verify the high efficiency of the IMI Pneumatex cyclonic vacuum degassing process in real applications, the Technische Universität Dresden, Professur für Gebäudeenergie-technik und Wärmeversorg-ung was commissioned to carry out various series of tests. For a better classification of the efficiency of IMI cyclonic vacuum degassing, other commercially available vacuum degassers were also measured in the same systems and under the same conditions.

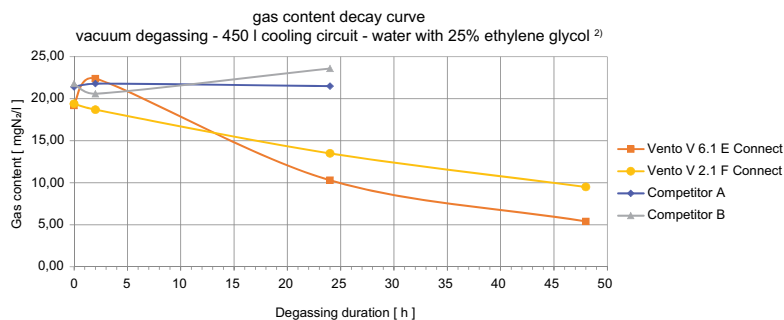
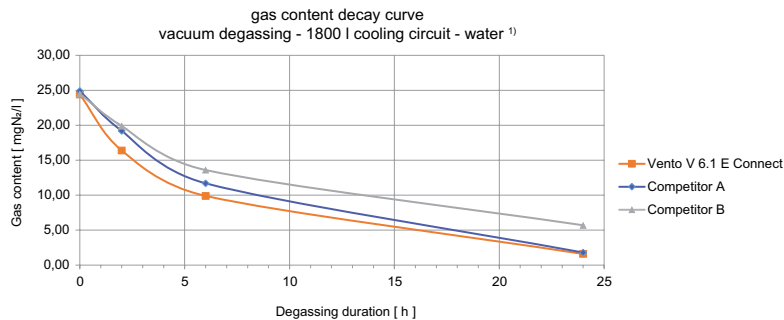

Tests for Competitors A and B were stopped after 24 hours because no degassing effect was visible. The increase in measurement values can be explained by the subsequent dissolution of N₂ gas bubbles in the circuit.

- 1) Ruhling, K. "Test von Entgasern in Technikums-Kreislaufen mit Wasser" Technische Universität Dresden, Professur für Gebäudeenergie-technik und Wärmeversorg-ung im Auftrag der IMI Hydronic Engineering Switzerland AG, November 2017 & January 2018.
- 2) Koch, F.; Ruhling, K.; Heymann, M. "Test von Entgasern in Technikums-Kreislaufen mit Wasser-Ethylenglykol-Gemisch" Technische Universität Dresden, Professur für Gebäudeenergie-technik und Wärmeversorg-ung, February 2022.

Setting values

For TAZ, Hst and psv in the “Parameter” menu of the BrainCube.

		TAZ = 100 °C	TAZ = 105 °C	TAZ = 110 °C
EN 12828	Check psv:	for psv ≤ 5 bar	$psv \geq 0,1 \cdot Hst + 1,4$	$psv \geq 0,1 \cdot Hst + 1,6$
		for psv > 5 bar	$psv \geq (0,1 \cdot Hst + 0,9) \cdot 1,11$	$psv \geq (0,1 \cdot Hst + 1,1) \cdot 1,11$
SWKI HE301-01		for psv ≤ 3 bar	$psv \geq (0,1 \cdot Hst + 1,0) \cdot 1,3$	$psv \geq (0,1 \cdot Hst + 1,2) \cdot 1,3$
		for psv > 3 bar	$psv \geq (0,1 \cdot Hst + 1,0) \cdot 1,15$	$psv \geq (0,1 \cdot Hst + 1,2) \cdot 1,15$

The BrainCube determines the switching points and the minimum pressure p0.

Equipment

Expansion pipes

Transfero TV_: table 6

Buffer vessels

At least one Statico SD 50 required for TV4, TV6, TV8 selection. SD 80 required for TV10 and TV14 (psvs ≤ 10 bar), and SH 150 for TV14 (10 bar < psvs ≤ 13 bar) selection.

Lock shield valve DLV

For SD 50/80 and SH 150 buffer vessels.

Pleno

Water make-up modules in combination with Transfero TV Connect. The control is made through the BrainCube of the Transfero TecBox. Connected water softening units must have a minimum flow rate of 1300 l/h for direct connection. If the water treatment unit has a lower flow rate a flow limiter in the inlet of the water meter must be used (a 240 l/h flow limiter is enclosed with the Transfero).

Pleno Refill

Water softening and demineralization modules in combination with Transfero TV Connect. The control is made through the BrainCube of the Transfero TecBox.

Intermediate vessel

An intermediate vessel is required for return temperatures higher than 70°C respectively lower than 5°C.

Zeparo

Air vent Zeparo ZUT or ZUP at each high point for venting during the filling and during the draining process. Separator for sludge and magnetite in each system in the main return to the heat generator.

Further accessories, product and selection details:

Datasheets Pleno Refill, Zeparo and Accessories.

Installation

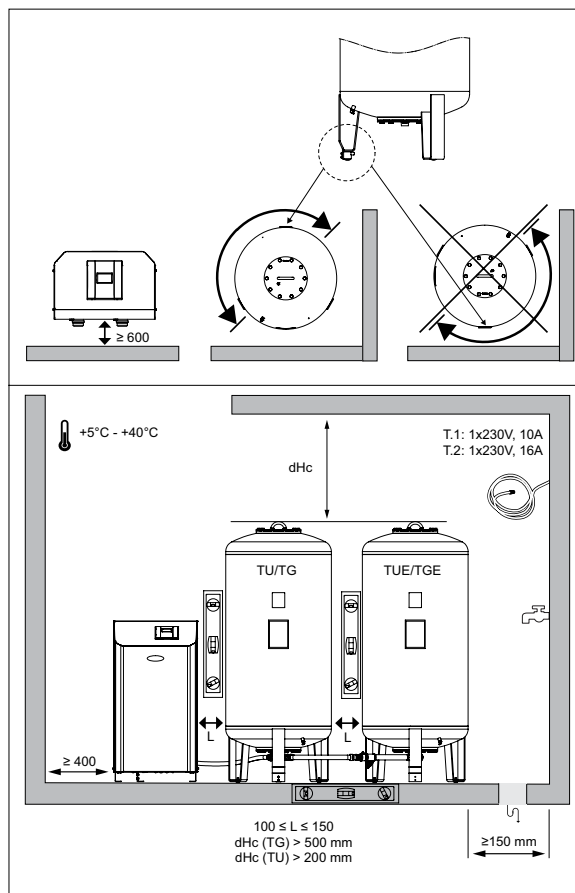

Principle scheme

Transfero TV1 Connect

Grey area is optional

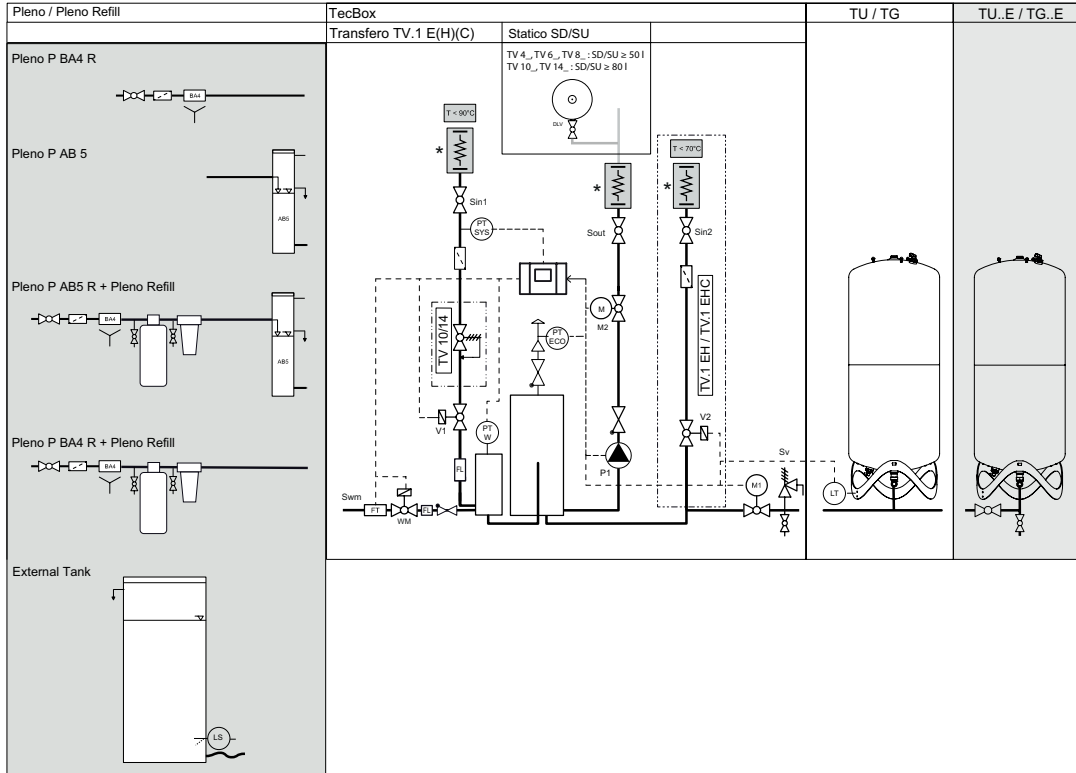

Transfero TV2 Connect

Grey area is optional

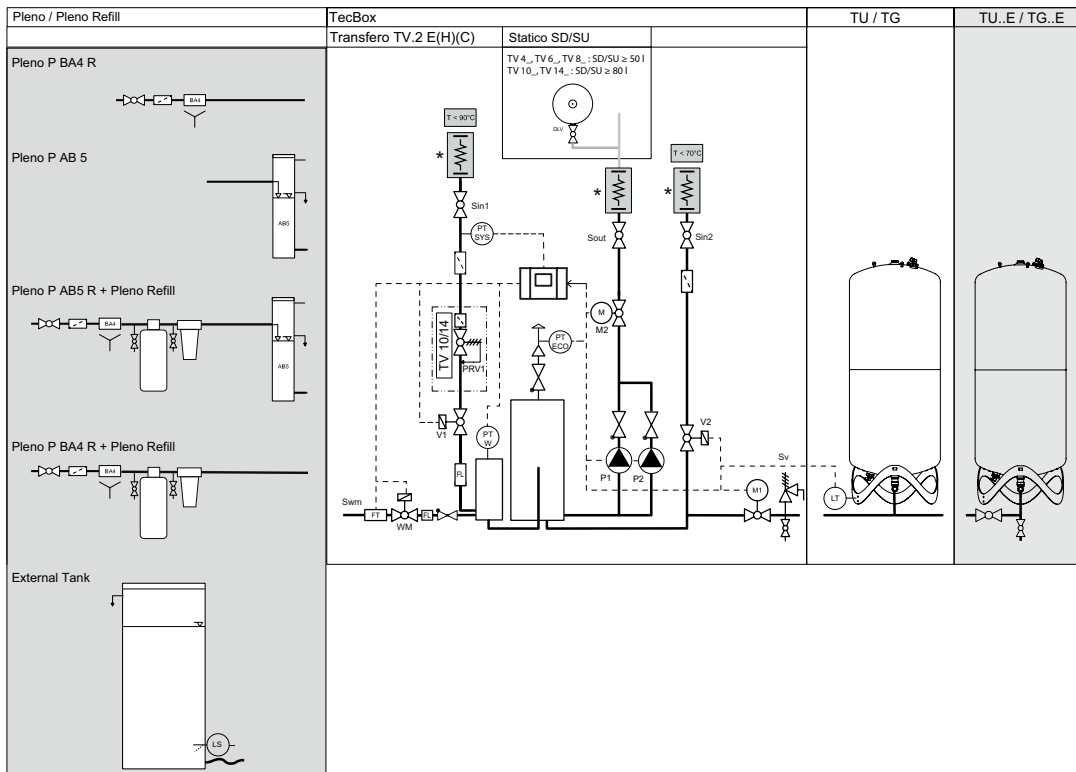

* When connecting to rigid piping, it is essential to ensure that there is no axial, vertical or horizontal tension. The connections must not be loaded with any additional weights. Maximum tightening torques must be observed where specified. If tightening torques are not specified, the state of the art for the respective connection must be observed. **A flexible connection is preferable to a rigid connection.**

Application examples

Transfero TV .1 E Connect

TecBox with 1 pump, precision pressure maintenance $\pm 0,2$ bar with cyclonic vacuum degassing, Pleno P BA4R for water make-up.

Example for heating systems, return temperature $tr \leq 70^\circ\text{C}$

(May require changes to meet local legislation)

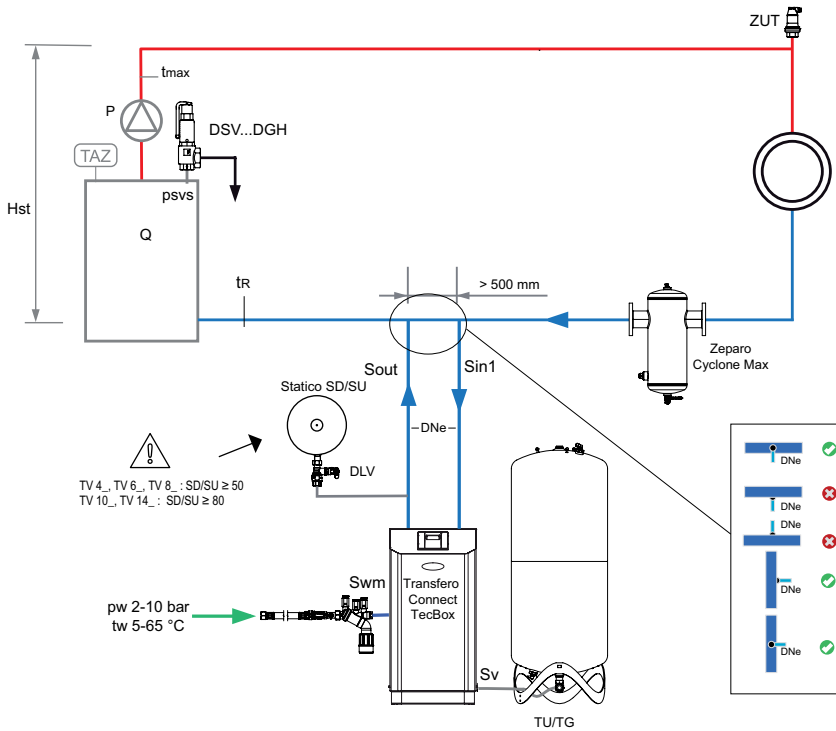

Transfero TV .2 EHC Connect

TecBox with 2 pumps, precision pressure maintenance $\pm 0,2$ bar with cyclonic vacuum degassing. Pleno P AB5 for water make-up.

Example for cooling systems, return temperature $0^\circ\text{C} < tr \leq 5^\circ\text{C}$

(May require changes to meet local legislation)

Scheme is also valid for Transfero TV .1EHC

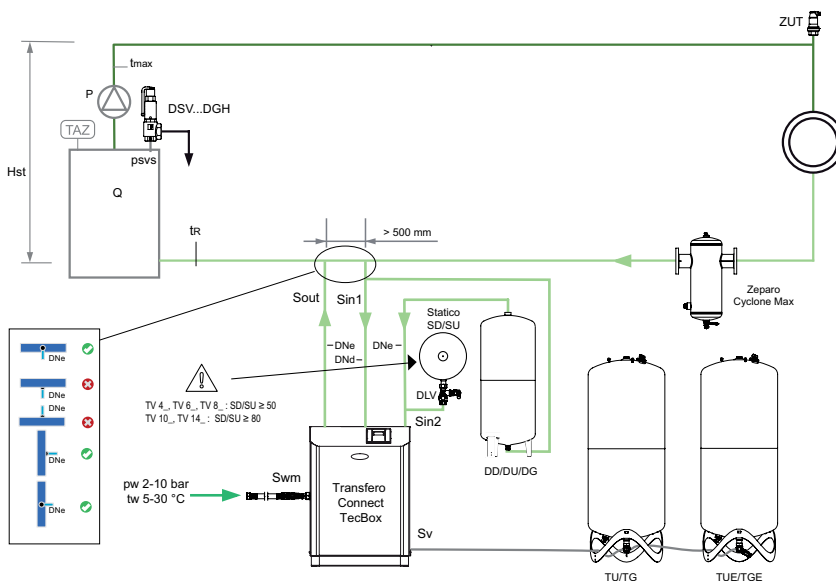

Zeparo Cyclone Max for the central separation of sludge.

Zeparo ZUT for automatic venting during filling and during draining.

Further accessories, product and selection details, see: Datasheet Pleno Connect, Zeparo and Accessories.

Transfero TV .2 EH Connect

TecBox with 2 pumps, precision pressure maintenance $\pm 0,2$ bar with cyclonic vacuum degassing, Pleno P AB5 R for the water make-up and Pleno Refill for water treatment.

Example for heating systems, return temperature $tr \leq 70^\circ\text{C}$

(May require changes to meet local legislation)

Scheme is also valid for Transfero TV .1EH

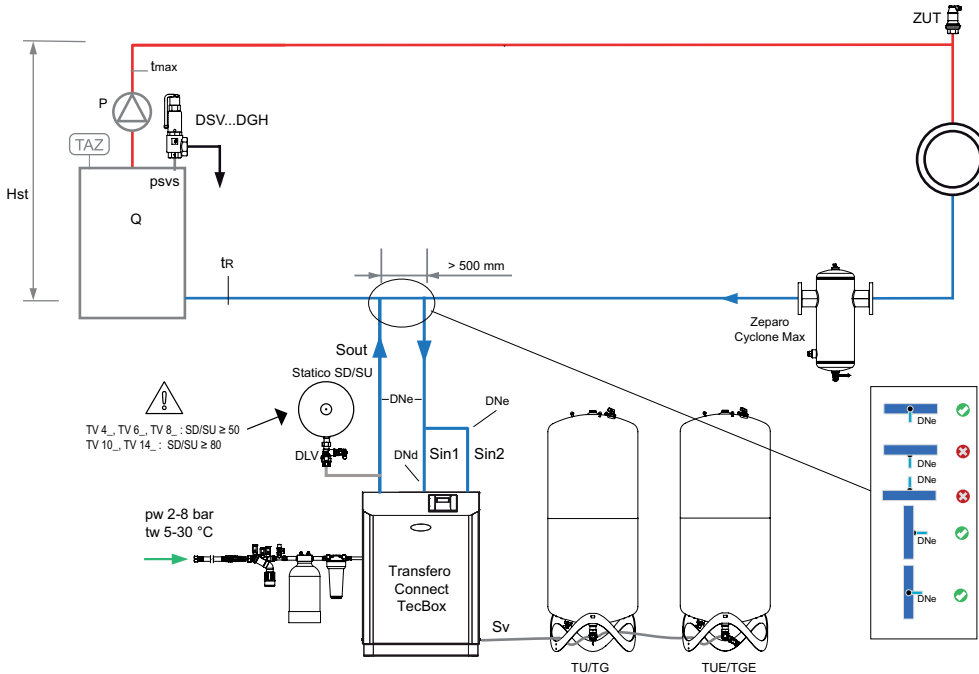

Transfero TV .2 EH Connect

TecBox with 2 pumps, precision pressure maintenance $\pm 0,2$ bar with cyclonic vacuum degassing, Pleno P AB5 R for the water make-up and Pleno Refill for water treatment.

Example for heating systems, return temperature $70^\circ\text{C} < tr \leq 90^\circ\text{C}$

(May require changes to meet local legislation)

Scheme is also valid for Transfero TV .1EH

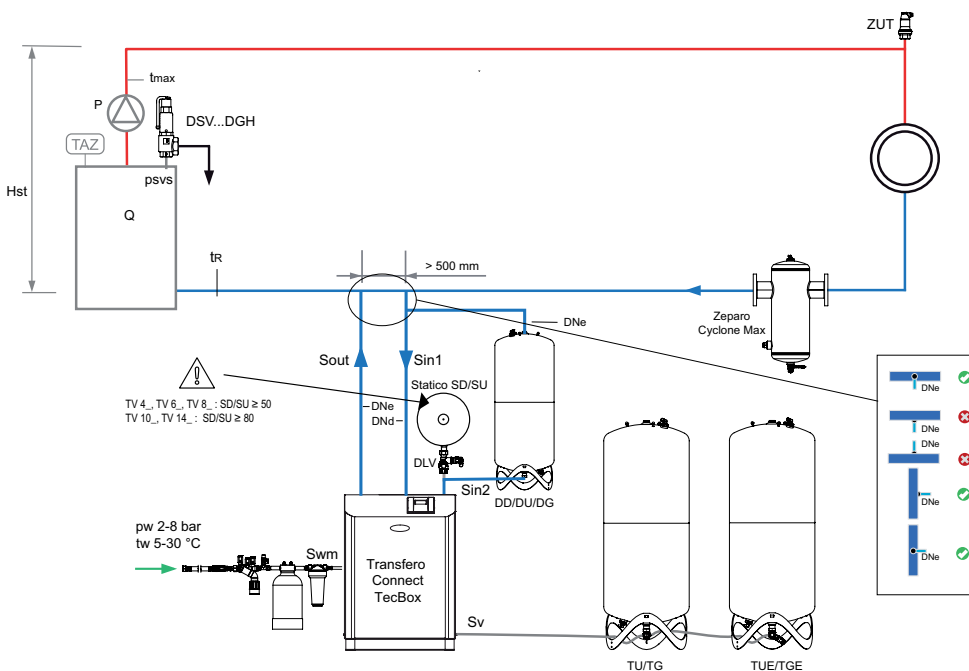

Zeparo Cyclone Max for the central separation of sludge.

Zeparo ZUT for automatic venting during filling and during draining.

Further accessories, product and selection details, see: Datasheet Pleno Connect, Zeparo and Accessories.

Master-Slave Pressure Control (PC/PCR) combined operation with Transero

TecBoxes for parallel (Master-Slave Pressure Control (PC/PCR) combined operation, precision pressure maintenance $\pm 0,2$ bar with cyclonic vacuum degassing, Pleno P AB5 R for the water make-up and Pleno Refill for water treatment.

Example for Master-Slave Pressure Control (PC/PCR) combined operation with a single primary vessel and multiple TecBoxes in heating systems, return temperature $tr \leq 70^\circ\text{C}$

(May require changes to meet local legislation)
Scheme is valid for all Transeros (Sin2 not for TV.1E)

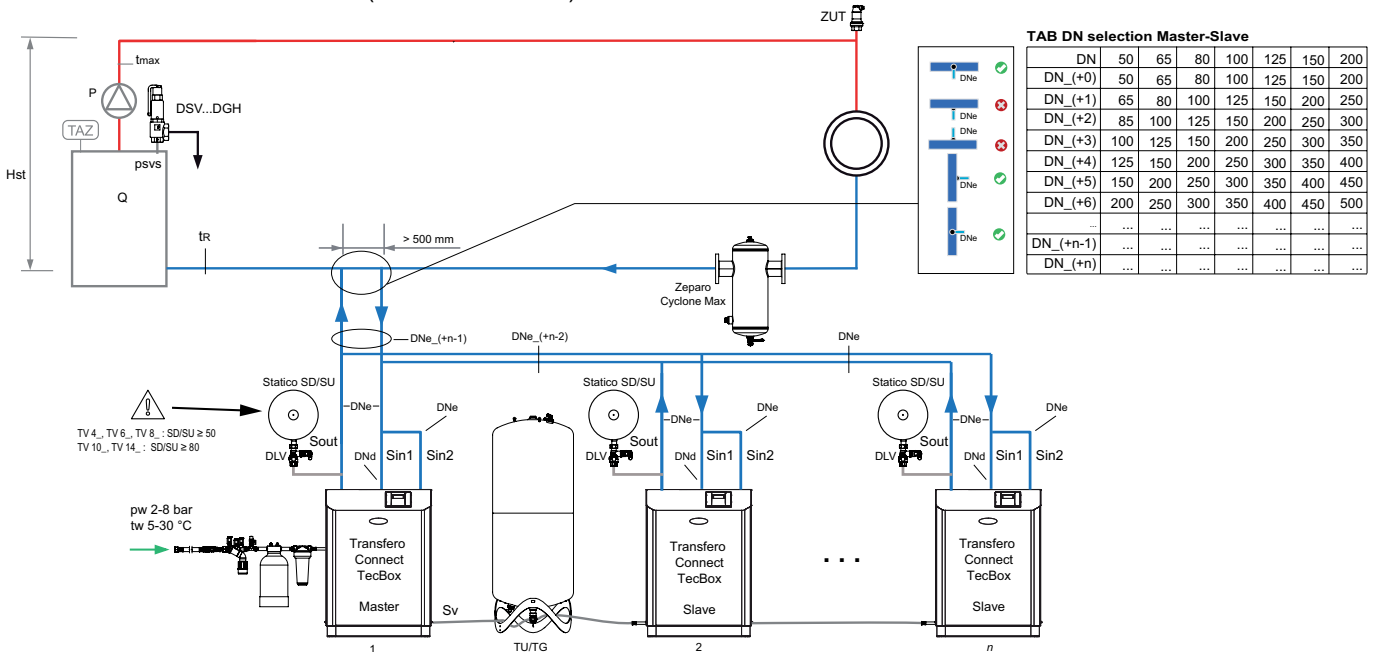

Example for Master-Slave Pressure Control (PC/PCR) combined operation with two primary vessels and multiple TecBoxes in heating systems, return temperature $70^\circ\text{C} < tr \leq 90^\circ\text{C}$

(May require changes to meet local legislation)
Scheme is valid for all Transeros (Sin2 not for TV.1E)

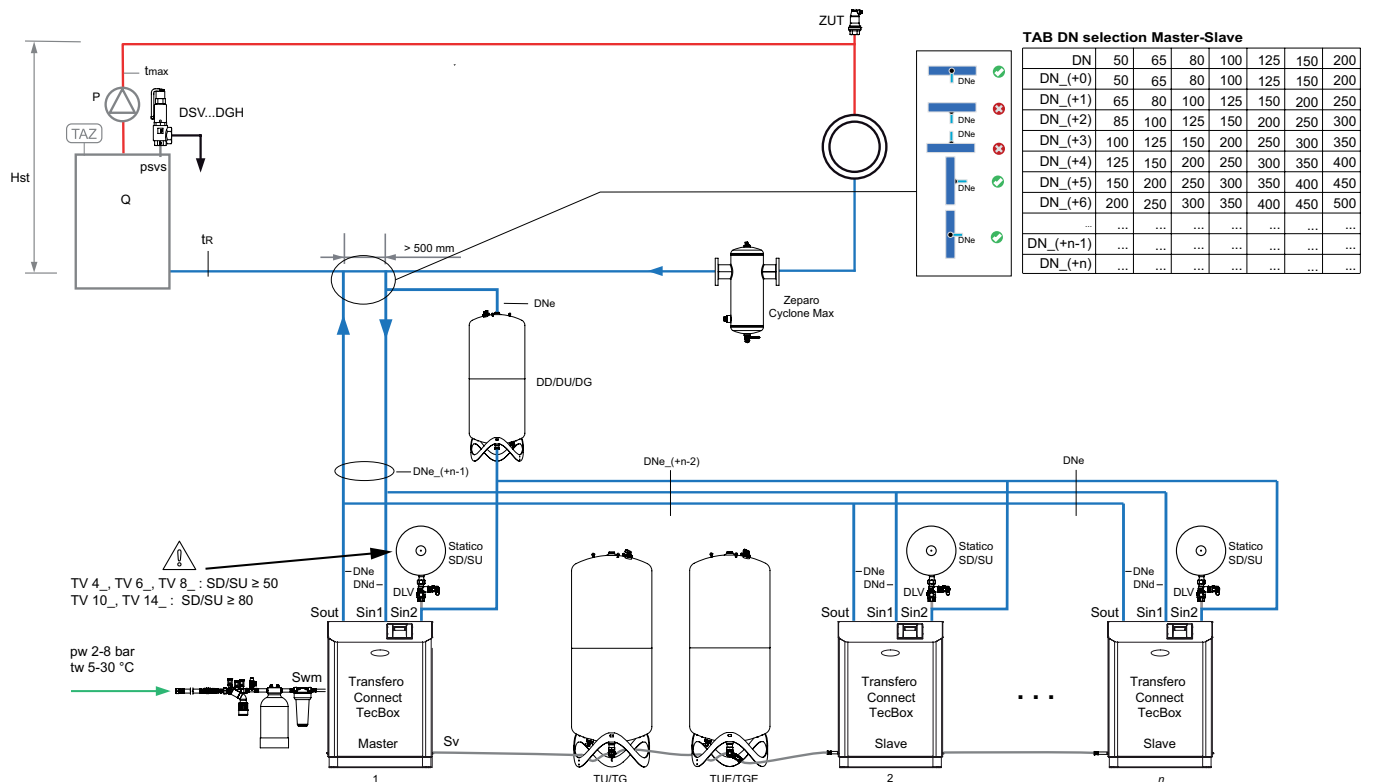

Zeparo Cyclone Max for the central separation of sludge.

Zeparo ZUT for automatic venting during filling and during draining.

Further accessories, product and selection details, see: Datasheet Pleno Connect, Zeparo and Accessories.

Control unit TecBox, Transfero TV Connect Heating

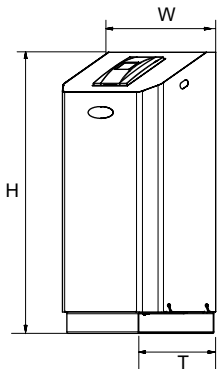

Transfero TV .1 E Connect

Precision pressure maintenance $\pm 0,2$ bar. 1 pump. 1 spill valve and two motor driven valves for degassing and pressurisation.

1 solenoid valve and 1 water meter for water make-up.

Type	W	H	T	m [kg]	PeI [kW]	dpu [bar]	SPL [dB(A)]	EAN	Article No
10 bar (PS)									
TV 4.1 E	500	920	530	42	0,75	1-2,5	~55*	7640161629462	811 1500
TV 6.1 E	500	920	530	44	1,1	1,5-3,5	~55*	7640161629479	811 1501
TV 8.1 E	500	920	530	45	1,4	2-4,5	~55*	7640161629486	811 1502
TV 10.1 E	500	1300	530	50	1,7	3,5-6,5	~60*	7640161629493	811 1503
13 bar (PS)									
TV 14.1 E	500	1300	530	69	1,7	5,5-10	~60*	7640161629509	811 1504

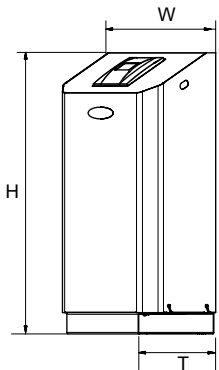

Transfero TV .1 EH Connect

Precision pressure maintenance $\pm 0,2$ bar. 1 pump. 1 spill valve and two motor driven valves for degassing and pressurisation. 1 spill valve for peak load pressurisation.

1 solenoid valve and 1 water meter for water make-up.

Type	W	H	T	m [kg]	PeI [kW]	dpu [bar]	SPL [dB(A)]	EAN	Article No
10 bar (PS)									
TV 4.1 EH	500	920	530	43	0,75	1-2,5	~55*	7640161629516	811 1510
TV 6.1 EH	500	920	530	46	1,1	1,5-3,5	~55*	7640161629523	811 1511
TV 8.1 EH	500	920	530	47	1,4	2-4,5	~55*	7640161629530	811 1512
TV 10.1 EH	500	1300	530	52	1,7	3,5-6,5	~60*	7640161629547	811 1513
13 bar (PS)									
TV 14.1 EH	500	1300	530	72	1,7	5,5-10	~60*	7640161629851	811 1514

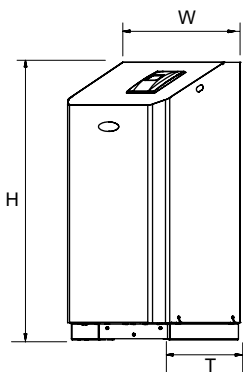

Transfero TV .2 EH Connect

Precision pressure maintenance $\pm 0,2$ bar. 2 pumps. 1 spill valve and two motor driven valves for degassing and pressurisation. 1 spill valve for peak load pressurisation.

1 solenoid valve and 1 water meter for water make-up.

Type	W	H	T	m [kg]	PeI [kW]	dpu [bar]	SPL [dB(A)]	EAN	Article No
10 bar (PS)									
TV 4.2 EH	680	920	530	54	1,5	1-2,5	~55*	7640161629554	811 1520
TV 6.2 EH	680	920	530	57	2,2	1,5-3,5	~55*	7640161629561	811 1521
TV 8.2 EH	680	920	530	60	2,8	2-4,5	~55*	7640161629578	811 1522
TV 10.2 EH	680	1300	530	70	3,4	3,5-6,5	~60*	7640161629585	811 1523
13 bar (PS)									
TV 14.2 EH	680	1300	530	97	3,4	5,5-10	~60*	7640161629592	811 1524

T = Depth of the device

dpu = Working pressure range

*) Pump operation

Control unit TecBox, Transero TV Connect Cooling

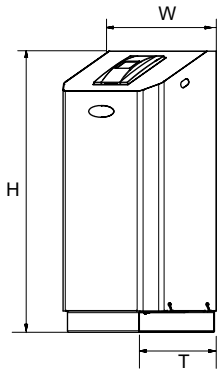

Transero TV .1 EC Connect

Precision pressure maintenance $\pm 0,2$ bar. 1 pump. 1 spill valve and two motor driven valves for degassing and pressurisation.

1 solenoid valve and 1 water meter for water make-up.

Cooling insulation with condensation water protection.

Type	W	H	T	m [kg]	Pel [kW]	dpu [bar]	SPL [dB(A)]	EAN	Article No
10 bar (PS)									
TV 4.1 EC	500	920	530	43	0,75	1-2,5	~55*	7640161629608	811 1530
TV 6.1 EC	500	920	530	45	1,1	1,5-3,5	~55*	7640161629615	811 1531
TV 8.1 EC	500	920	530	46	1,4	2-4,5	~55*	7640161629622	811 1532
TV 10.1 EC	500	1300	530	51	1,7	3,5-6,5	~60*	7640161629639	811 1533
13 bar (PS)									
TV 14.1 EC	500	1300	530	70	1,7	5,5-10	~60*	7640161629646	811 1534

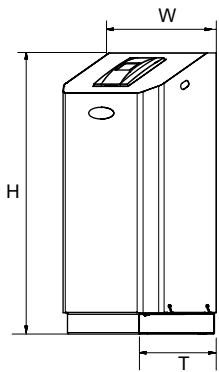

Transero TV .1 EHC Connect

Precision pressure maintenance $\pm 0,2$ bar. 1 pump. 1 spill valve and two motor driven valves for degassing and pressurisation. 1 spill valve for peak load pressurisation.

1 solenoid valve and 1 water meter for water make-up.

Cooling insulation with condensation water protection.

Type	W	H	T	m [kg]	Pel [kW]	dpu [bar]	SPL [dB(A)]	EAN	Article No
10 bar (PS)									
TV 4.1 EHC	500	920	530	44	0,75	1-2,5	~55*	7640161629653	811 1540
TV 6.1 EHC	500	920	530	47	1,1	1,5-3,5	~55*	7640161629660	811 1541
TV 8.1 EHC	500	920	530	48	1,4	2-4,5	~55*	7640161629677	811 1542
TV 10.1 EHC	500	1300	530	51	1,7	3,5-6,5	~60*	7640161629684	811 1543
13 bar (PS)									
TV 14.1 EHC	500	1300	530	73	1,7	5,5-10	~60*	7640161629868	811 1544

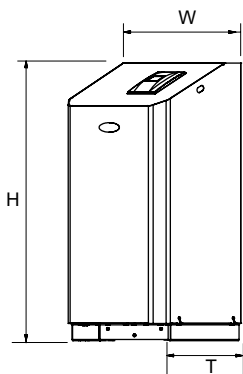

Transero TV .2 EHC Connect

Precision pressure maintenance $\pm 0,2$ bar. 2 pumps. 1 spill valve and two motor driven valves for degassing and pressurisation. 1 spill valve for peak load pressurisation.

1 solenoid valve and 1 water meter for water make-up.

Cooling insulation with condensation water protection.

Type	W	H	T	m [kg]	Pel [kW]	dpu [bar]	SPL [dB(A)]	EAN	Article No
10 bar (PS)									
TV 4.2 EHC	680	920	530	55	1,5	1-2,5	~55*	7640161629691	811 1550
TV 6.2 EHC	680	920	530	58	2,2	1,5-3,5	~55*	7640161629707	811 1551
TV 8.2 EHC	680	920	530	61	2,8	2-4,5	~55*	7640161629714	811 1552
TV 10.2 EHC	680	1300	530	71	3,4	3,5-6,5	~60*	7640161629721	811 1553
13 bar (PS)									
TV 14.2 EHC	680	1300	530	98	3,4	5,5-10	~60*	7640161629738	811 1554

T = Depth of the device

dpu = Working pressure range

*) Pump operation

Expansion vessels, Transfero TU/TU...E

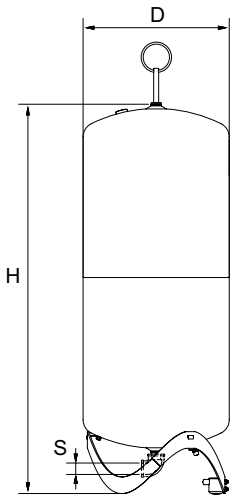

Transfero TU

Primary vessel. Measuring foot for content measurement.
Including assembly kit for the water-side connection.

Type	VN [l]	D	H	H***	m [kg]	S	EAN	Article No
2 bar (PS)								
TU 200	200	500	1339	1565	36	Rp 1 1/4	7640148631594	713 1000
TU 300	300	560	1469	1690	41	Rp 1 1/4	7640148631600	713 1001
TU 400	400	620	1532	1760	58	Rp 1 1/4	7640148631617	713 1002
TU 500	500	680	1627	1858	68	Rp 1 1/4	7640148631624	713 1003
TU 600	600	740	1638	1873	78	Rp 1 1/4	7640148631631	713 1004
TU 800	800	740	2132	2360	99	Rp 1 1/4	7640148631648	713 1005

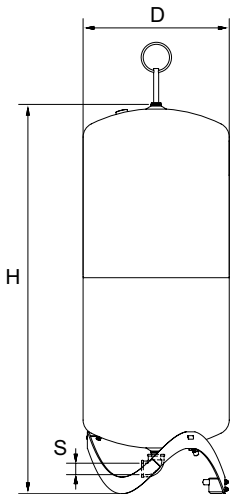

Transfero TU...E

Secondary vessel.
Including assembly kit for the water-side connection, flexible hose and lock shield valve with ball valve for fast draining.

Type	VN [l]	D	H	H***	m [kg]	S	EAN	Article No
2 bar (PS)								
TU 200 E	200	500	1339	1565	35	Rp 1 1/4	7640148631655	713 2000
TU 300 E	300	560	1469	1690	40	Rp 1 1/4	7640148631662	713 2001
TU 400 E	400	620	1532	1760	57	Rp 1 1/4	7640148631679	713 2002
TU 500 E	500	680	1627	1868	67	Rp 1 1/4	7640148631686	713 2003
TU 600 E	600	740	1638	1873	75	Rp 1 1/4	7640148631693	713 2004
TU 800 E	800	740	2132	2360	98	Rp 1 1/4	7640148631709	713 2005

VN = Nominal volume

***) Max. height when vessel is tilted

Expansion vessels, Transfero TG/TG...E

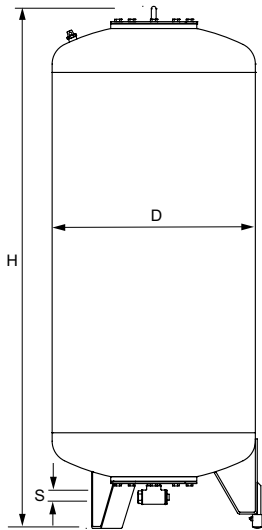

Transfero TG

Primary vessel. Measuring foot for content measurement.
Including assembly kit for the water-side connection.

Type *	VN [l]	D	H	H***	m [kg]	S	EAN	Article No
2 bar (PS)								
TG 1000	1000	850	2199	2210	280	Rp 1 1/4	7640148631716	713 1006
TG 1500	1500	1016	2351	2381	360	Rp 1 1/4	7640148631723	713 1007
TG 2000	2000	1016	2848	2876	640	Rp 1 1/4	7640148631730	713 1012
TG 3000	3000	1300	2951	3016	800	Rp 1 1/4	7640148631747	713 1009
TG 4000	4000	1300	3592	3633	910	Rp 1 1/4	7640148631754	713 1010
TG 5000	5000	1300	4216	4275	1010	Rp 1 1/4	7640148631761	713 1011

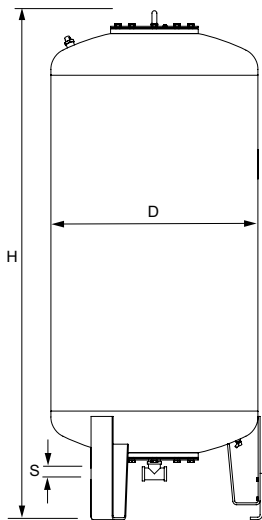

Transfero TG...E

Secondary vessel.

Including flexible hose for the water-side connection and lock shield valve with ball valve for fast draining.

Type *	VN [l]	D	H	H***	m [kg]	S	Sw	EAN	Article No
2 bar (PS)									
TG 1000 E	1000	850	2199	2210	280	Rp 1 1/4	G3/4	7640148631778	713 2006
TG 1500 E	1500	1016	2351	2381	360	Rp 1 1/4	G3/4	7640148631785	713 2007
TG 2000 E	2000	1016	2848	2876	640	Rp 1 1/4	G3/4	7640148631792	713 2012
TG 3000 E	3000	1300	2951	3016	800	Rp 1 1/4	G3/4	7640148631808	713 2009
TG 4000 E	4000	1300	3592	3633	910	Rp 1 1/4	G3/4	7640148631815	713 2010
TG 5000 E	5000	1300	4216	4275	1010	Rp 1 1/4	G3/4	7640148631822	713 2011

VN = Nominal volume

SW = Draining

*) Special vessel upon request.

***) Max. height when vessel is tilted, tolerance 0 +/-100.

Lock shield valve for buffer vessel

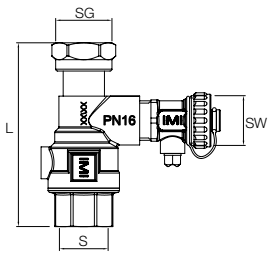

Lock shield valve DLV

Female thread on both sides, flat sealing union for direct connection to all suitable expansion vessels.

Type	PS [bar]	L	m [kg]	S	SG	SW	EAN	Article No
DLV 20	16	97	0,49	Rp3/4	G3/4	G3/4	7640148638579	535 1434
DLV 25	16	100	0,54	Rp1	G1	G3/4	7640148638586	535 1436

Buffer Vessel

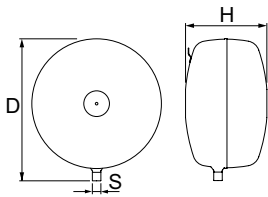

Statico SD

Discus shaped

Type	VN [l]	p0 [bar]	D	H	m [kg]	S	EAN	Article No
Transfero TV 4,6,8								
SD 50.10	50	4	536	316**	12	R3/4	7640148630139	710 3005
Transfero TV 10, 14 (psvs ≤ 10 bar)								
SD 80.10	80	4	636	346**	16	R3/4	7640148630146	710 3006

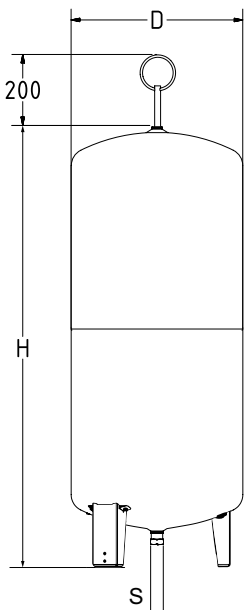

Statico SU

Cylindrical shape, to be used with the Transfero TV 14 (10 bar < psvs ≤ 13 bar).

Type	VN [l]	p0 [bar]	D	H	H***	m [kg]	S	EAN	Article No
10 bar (PS)									
SU 140.10	140	4	420	1274	1489	32	R3/4	7640148630290	710 3007

VN = Nominal volume

H Tolerance 0 /+35

***) Max. height when vessel is tilted

Pleno P water make-up modules

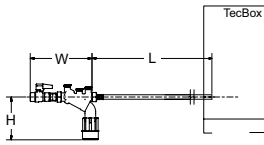

Pleno P BA4 R

Hydraulic unit for water make-up operation with Vento/Transfero Connect, Pleno PX/PIX, Simply Compresso C 2.1-80 SWM, and in combination with Pleno Refill modules. Features a shut off valve, check valve, filter and a type BA backflow preventer (protection class 4) according to EN 1717. Connection (Swm): G1/2

Type	PS [bar]	W	L	H	m [kg]	qwm [l/h]	EAN	Article No
BA4 R	10	210	1300	135	1,1	350* 250** 50***	7640161630147	813 3310
q(pw-pout) ****								

qwm = make-up water flow

* maximum average value for make-up water degassing with Vento V/VI and Transfero TV/TVI

** maximum average value for make-up water degassing with Vento Compact

*** when using flow limiter for operation with low flow water treatment cartridges

**** for combination with Pleno PX/PIX see q(pw-pout) diagram in Pleno Connect datasheet

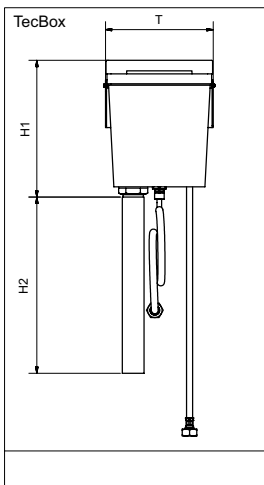

Pleno P AB5

Hydraulic unit for water make up operation with Vento/Transfero Connect. Consists of a breaktank type AB (protection class 5) according EN 1717. For installation on the back of each unit. Can be used for 3rd party softening modules which do not fulfil the requirement of qwm min 1300 l/h and therefore cannot be directly connected.

Type	PS [bar]	T	H1	H2	m [kg]	qwm [l/h]	EAN	Article No
AB5	10	220	280	1000	1,83	200	7640161630154	813 3320

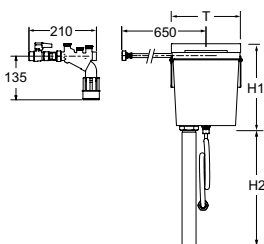

Pleno P AB5 R

Hydraulic unit for water make up operation with Vento/Transfero Connect. Consists of Pleno P BA4 R back flow preventer and Pleno P AB5 modules, with protection class 5 according to EN 1717.

Type	PS [bar]	T	H1	H2	m [kg]	qwm [l/h]	EAN	Article No
AB5 R	10	220	280	1000	3,8	200	7640161630161	813 3330

qwm = make-up water flow

T = Depth of the device

Pleno Refill

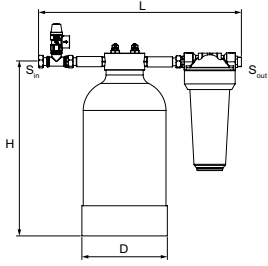

Pleno Refill

Hydraulic unit for water softening together with Vento/Transfero Connect TecBoxes. Filter with 25 µm mesh size to protect the hydronic system. Softening bottle filled with high grade resin.

3/4" swivelling nut, 3/4" external thread suitable for flat gasket.

Nominal pressure: PS 8

Max. working temperature: 45°C

Min. working temperature: > 4°C

Type	Capacity l x °dH	S _{in}	S _{out}	D	H	L	m [kg]	EAN	Article No
Refill 16000	16000	G3/4	G3/4	195	383	455	9,1	7640161630475	813 3210
Refill 36000	36000	G3/4	G3/4	220	466	455	13	7640161630482	813 3220
Refill 48000	48000	G3/4	G3/4	270	458	455	16,2	7640161630499	813 3230

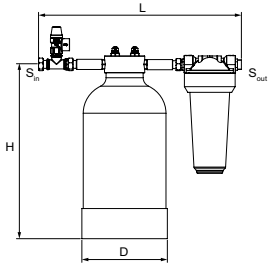

Pleno Refill Demin

Hydraulic unit for water demineralisation together with Vento/Transfero Connect TecBoxes. Filter with 25 µm mesh size to protect the hydronic system. Desalination bottle filled with high grade resin.

3/4" swivelling nut, 3/4" external thread suitable for flat gasket.

Nominal pressure: PS 8

Max. working temperature: 45°C

Min. working temperature: > 4°C

Type	Capacity l x °dH	S _{in}	S _{out}	D	H	L	m [kg]	EAN	Article No
Refill Demin 13500	13500	G3/4	G3/4	220	466	455	13	7640161630505	813 3260
Refill Demin 18000	18000	G3/4	G3/4	270	458	455	16,2	7640161630512	813 3270

Additional information:

System design: Datasheet Planning and calculation.

Calculation: Software HySelect

Abbreviations and terminology: Datasheet Planning and calculation.

Further accessories, product and selection details, see: Datasheet Pleno, Zeparo and Accessories.

Wiring diagrams

Power supply Transero TV.1

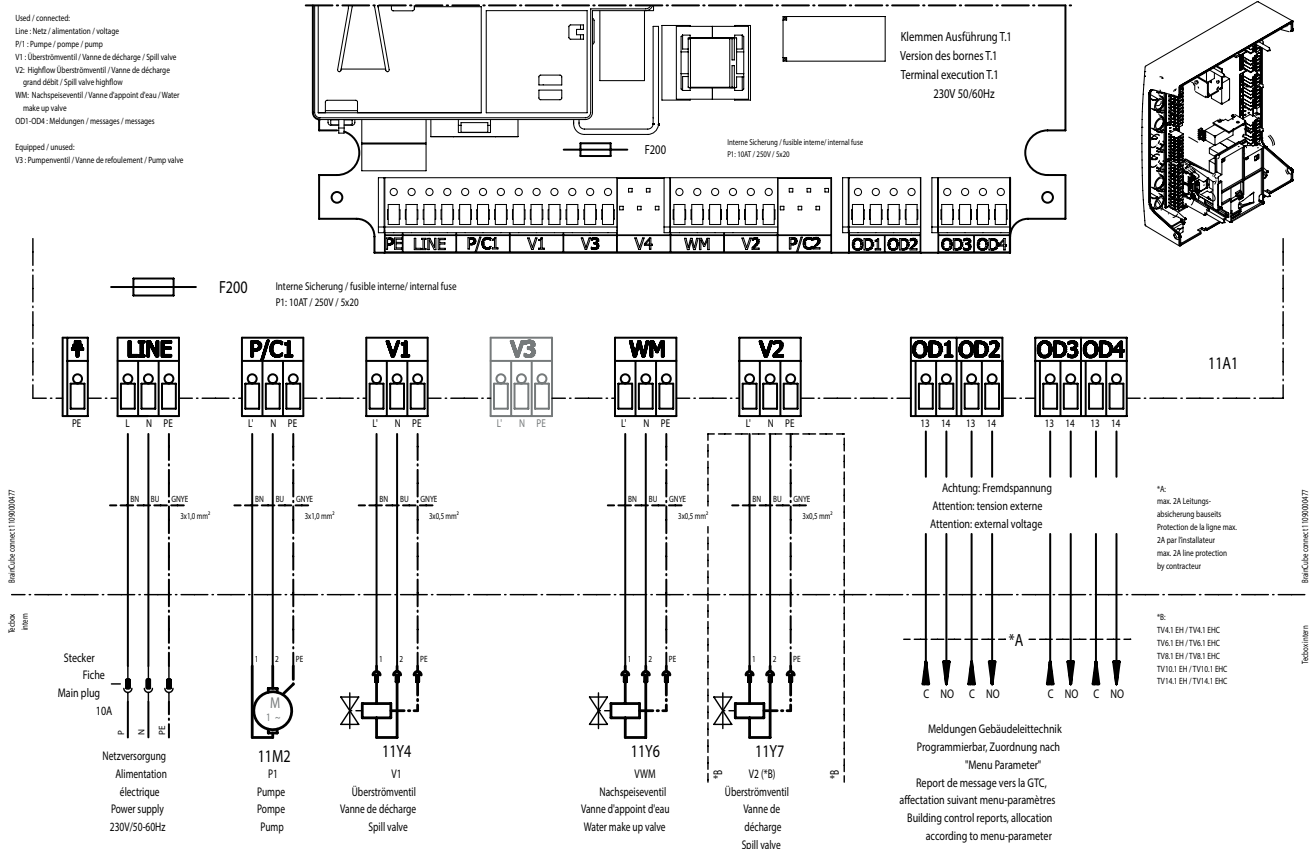

Power supply Transero TV.2

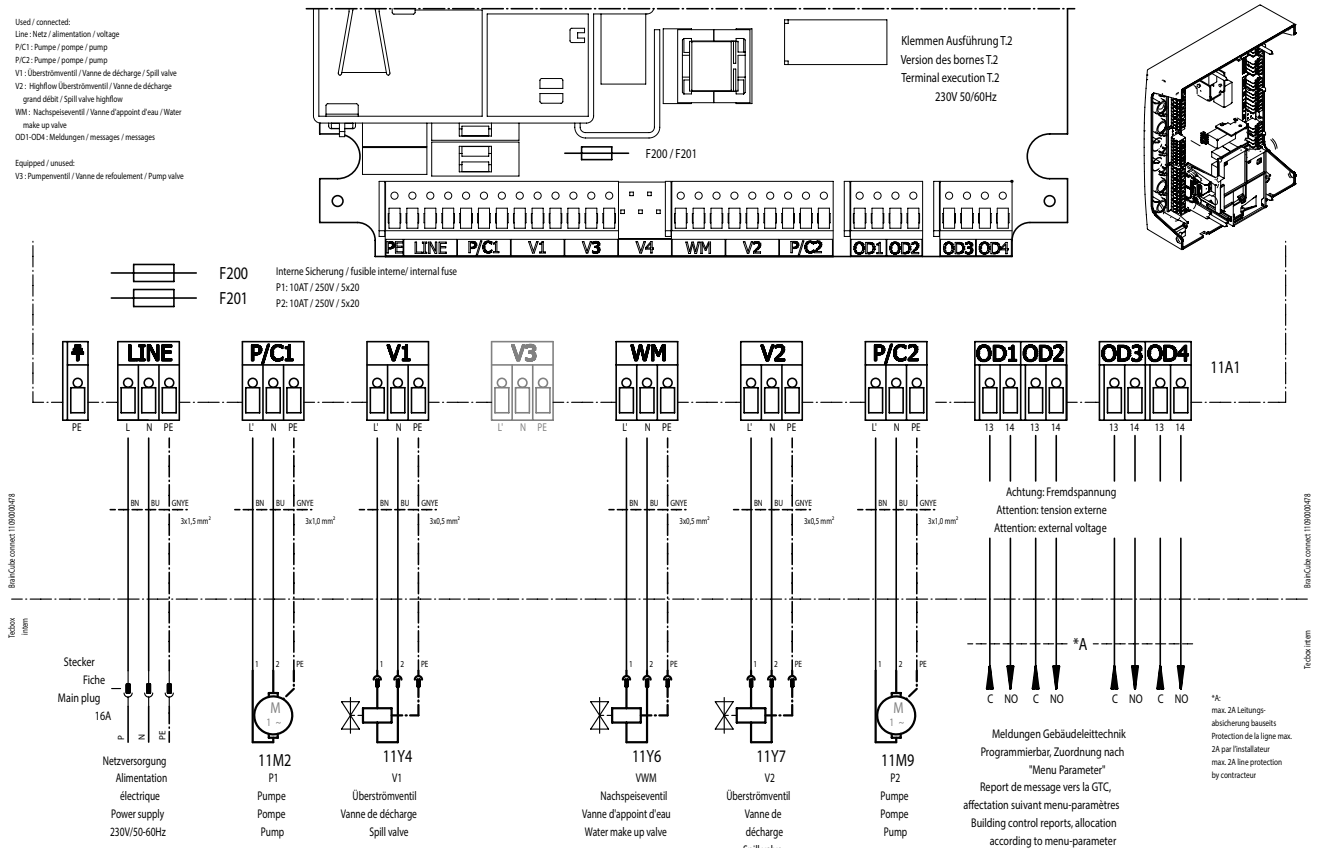

Communication

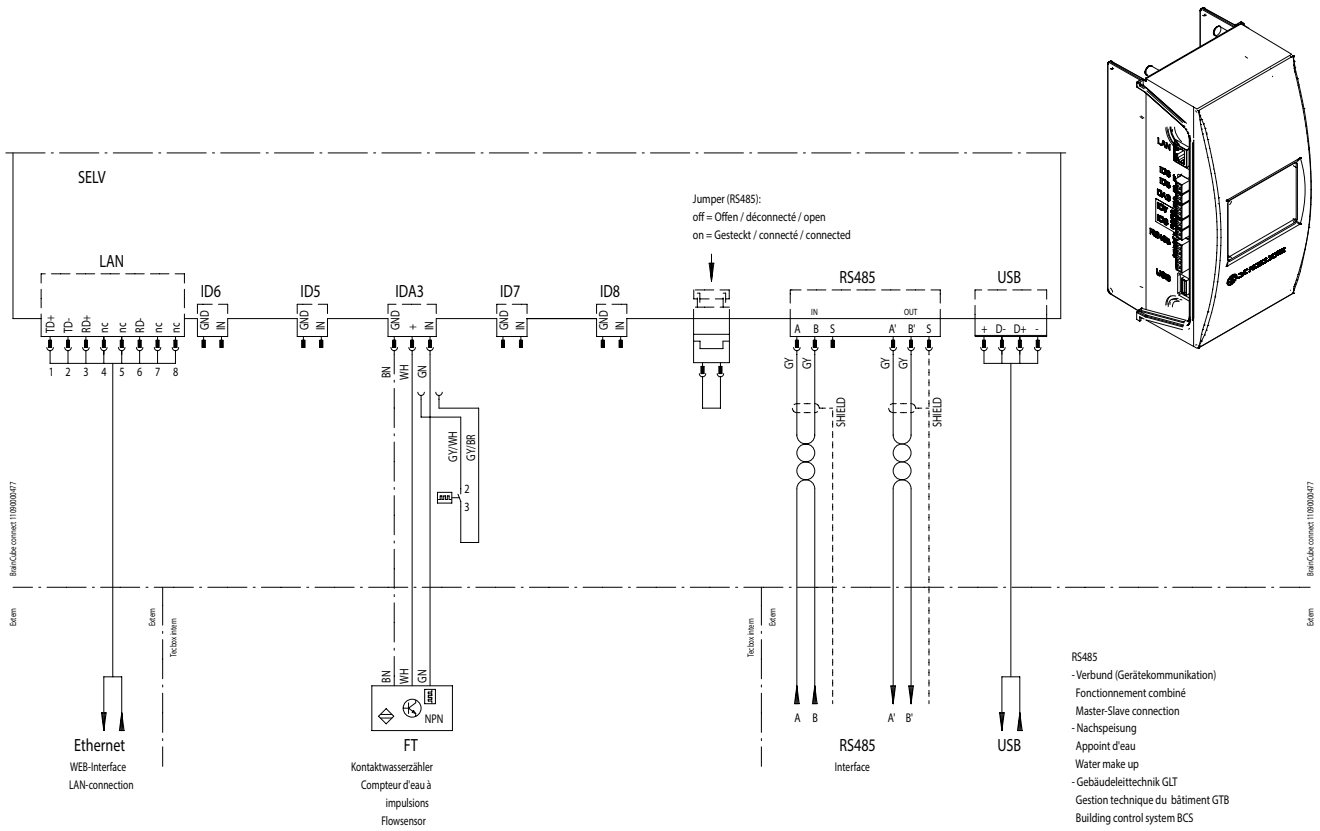

The products, texts, photographs, graphics and diagrams in this document may be subject to alteration by IMI without prior notice or reasons being given. For the most up to date information about our products and specifications, please visit climatecontrol.imiplc.com.