

Climate
Control

IMI TA

TA-Slider 500 T-2T



Actuators

Digitally configurable proportional push-pull actuator
with temperature measurement capability –
500/300 N

TA-Slider 500 T-2T

Digitally configurable actuators with temperature measurement capability and operation, to be used as a terminal unit actuator mounted on a PIBCV for tackling ΔT syndrome or for handling changeover based on T supply or ΔT sign detection. A wide range of setup options provide extensive flexibility for on-site parameter adaptation. Fully programmable binary input, relay and adjustable max. stroke of the valve bring new opportunities for advanced hydronic control and balancing.



Key features

Optional ΔT and temperature return limitation

Optimize the efficiency of your production units by ensuring optimal temperature regimes.

Change-over functionality

Switch between heating/cooling flows according to input signal or automatically using T supply or ΔT sign detection.

Convenient, reliable setup

Fully customisable by smartphone via Bluetooth using a TA-Dongle.

Easy diagnostics

Tracks the last 10 errors to allow system faults to be found quickly.

Quick copying of settings

Setup configuration can be copied quickly from the TA-Dongle to identical TA-Slider actuators.

Technical description

Functions:

Proportional control
 Manual override (TA-Dongle)
 Stroke detection
 Mode, status and position indication
 Stroke limitation setting
 Minimum stroke setting
 Valve blockage protection
 Valve clogging detection
 Error safe position
 Diagnostic/Logging
 Delayed start-up
 ΔT and temperature return limitation
 Reading (supply/return temperature, ΔT , position)
 Automatic change-over function

T version:

+ 1 pre-mounted Pt1000 to be inserted in valve measuring point.
 + 1 binary input, max. 100 Ω , cable max. 10 m or shielded.
 + Output signal

2T version:

+ 1 pre-mounted cable with possibility to connect 2 Pt1000 (see section "Sensors")
 + 1 binary input, max. 100 Ω , cable max. 10 m or shielded.
 + Output signal

Supply voltage:

24 VAC/VDC $\pm 15\%$.
 Frequency 50/60 Hz ± 3 Hz.

Power consumption:

Operation: < 3.6 VA (VAC); < 1.7 W (VDC)
 Standby: < 1.3 VA (VAC); < 0.6 W (VDC)

Input signal:

0(2)-10 VDC, R_i 47 k Ω .
 Adjustable hysteresis sensitivity
 0.1-0.5 VDC.
 0.33 Hz low pass filter.
 Proportional:
 0-10, 10-0, 2-10 or 10-2 VDC.
 Proportional split-range:
 0-5, 5-0, 5-10 or 10-5 VDC.
 0-4.5, 4.5-0, 5.5-10 or 10-5.5 VDC.
 2-6, 6-2, 6-10 or 10-6 VDC.
 Proportional dual-range (for change-over):
 0-3.3 / 6.7-10 VDC,
 2-4.7 / 7.3-10 VDC,
 0-4.5 / 5.5-10 VDC or
 2-5.5 / 6.5-10 VDC.
 Default setting: Proportional 0-10 VDC.

Output signal:

0(2)-10 VDC, max. 8 mA, min. 1.25 k Ω .
 Ranges: See "Input signal".
 Default setting: Proportional 0-10 VDC.

Characteristics:

Linear, EQM 0.25 and inverted EQM 0.25.
 Default setting: Linear.

Control speed:

4 or 6 s/mm.
 Default setting: 4 s/mm.

Adjusting force:

Push 500 N
 Pull 300 N

Temperature:

Media temperature: max. 120°C
 Operating environment: 0°C – +50°C (5-95%RH, non-condensing)
 Storage environment: -20°C – +70°C (5-95%RH, non-condensing)

Measurement accuracy:

Temperature pocket: Class AA
 In valve measuring point: Class B
 Surface mounted: Class B

Absolute temperature:

Pt1000 Class AA: $\pm 0.1^{\circ}\text{C}$ at 0°C
 Pt1000 Class B: $\pm 0.3^{\circ}\text{C}$ at 0°C

Time constant τ (63%):

In valve measuring point: 5s
 Temperature pocket: 9s
 Surface mounted: 20s

Ingress protection:

IP54 all directions
 (according to EN 60529)

Protection class:

(according to EN 61140)
 III (SELV)

Cable:

1, 2 or 5 m.
 Halogen free with wire end sleeves.
 Fire class B2_{ca} – s1a, d1, a1 according to EN 50575.
 Type LiYY, 5x0.25 mm².

Temperature sensor cable:

Halogen free, fire class IEC 60332-3-24 (cat. C).

T version: Length 160 mm.
 2T version: Length, see section "Sensors".

Stroke:

16,2 mm

Noise level:

Max. 30 dBA

Weight:

TA-Slider 500 T:
 0.29 kg, 1 m cable
 0.34 kg, 2 m cable
 0.49 kg, 5 m cable
 TA-Slider 500 2T:
 0.34 kg, 1 m cable
 0.39 kg, 2 m cable
 0.54 kg, 5 m cable

Connection to valve:

Swivelling nut M30x1,5.

Material:

Cover: PC/ABS GF8
 Housing: PA GF40.
 Swivelling nut: Nickel-plated brass.
 Cables: Halogen free

Colour:

White RAL 9016, grey RAL 7047.

Marking:

Label: IMI TA, CE, product name, article No. and technical specification.

Certification CE:

LV-D. 2014/35/EU: EN 60730-1, -2-14.
 EMC-D. 2014/30/EU: EN 60730-1, -2-14.
 RoHS-D. 2011/65/EU: EN 63000.

Product standard:

EN 60730

Function

Setting

The actuator can be set by the HyTune app (iOS version 16 or later, Android version 9 or later) + the TA-Dongle device, with or without the actuator power supplied.

The setting configuration can be stored in the TA-Dongle for setting of one or several actuators. Connect the TA-Dongle to the actuator and press the configuration button. HyTune can be downloaded from the App Store or Google Play.

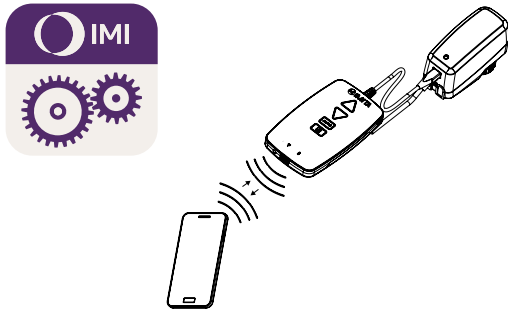

Manual override

By using the TA-Dongle device. No power supply needed.

Calibration/Stroke detection

According to selected settings in the table.

Type of calibration	At power on	After manual override
Both end positions (full)	√ *	√
Fully extended position (fast)	√	√ *
None	√	

*) Default

Note: A calibration refresh can be automatically repeated monthly or weekly.
Default setting: Off.

Stroke limitation setting

A maximum stroke smaller than or equal to the detected valve lift can be set to the actuator.

For some IMI TA/IMI Heimeier valves it can also be set to a Kv_{max}/q_{max} .

Default setting: No stroke limitation (100%).

Minimum stroke setting

The actuator can be set with a minimum stroke below which it will not go (except for calibration).

For some IMI TA/IMI Heimeier valves, it can also be set to a q_{min} .

Default setting: No minimum stroke (0%).

Valve blockage protection

The actuator will perform a quarter of a full stroke and then back to desired value if no actuation takes place for one week or one month.

Default setting: Off.

Valve clogging detection

If actuation stops before the desired value is reached, the actuator moves back ready to make a new attempt. The actuator will move to the configured error safe position after three attempts.

Default setting: On.

Error safe position

Fully extended or retracted position when following errors occur; low power, line break, valve clogging or stroke detection failure.

Default setting: Fully extended position.

Diagnostics/logging

The last 10 errors (low power, line break, valve clogging, stroke detection failure) with time stamps can be read using the HyTune app + TA-Dongle device. Logged errors will be cleared if the power is disconnected.

Delayed start-up

The actuator can be specified a delay (0 to 1275 sec.) before starting up after a power supply cut. This is useful when used with a control system that has itself a long start-up time.

Default setting: 0 seconds.

Binary input

If the binary input circuit is open, the actuator will go to a set stroke, switch to a second stroke limitation setting or drive to its full stroke regardless of any limitations for flushing purpose.

Change-over system detection

Switching between two different stroke limitation settings by toggling the binary input or using the dual-range input signal.

ΔT and temperature return limitation

Ensure your terminal unit installation is properly balanced and optimize the efficiency of your production units by ensuring optimal temperature regimes.

LED indication

	Status	Red (heating) / Blue (cooling)
	— — — —	Fully retracted (actuator stem) Long pulse - Short pulse
	— — — —	Fully extended (actuator stem) Short pulse - Long pulse
	— — — —	Intermediate position Long pulses
	— — — —	Moving Short pulses
	— — — —	Calibrating 2 short pulses
		Manual mode or no power supply Off

	Error code	Violet
	- - -	Power supply too low 1 pulse
	- - -	Line broken (2-10 V) 2 pulses
	- - -	Valve clogging or foreign object 3 pulses
	- - -	Stroke detection failure 4 pulses

If an error is detected, violet pulses are displayed as the red or blue status lights flash alternately. More detailed information, please see the HyTune app + TA-Dongle.

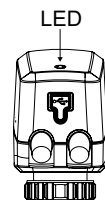

Installation

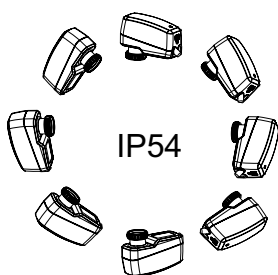

Note!

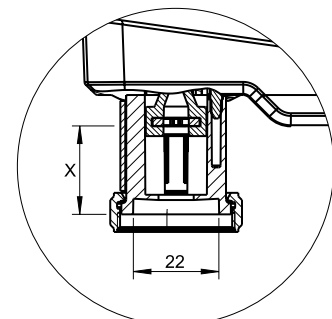
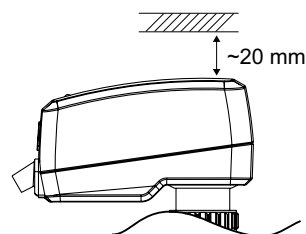

X = 7.7 - 23.9 mm

Connection diagram

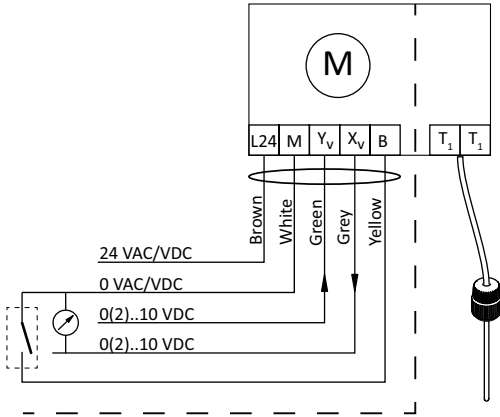
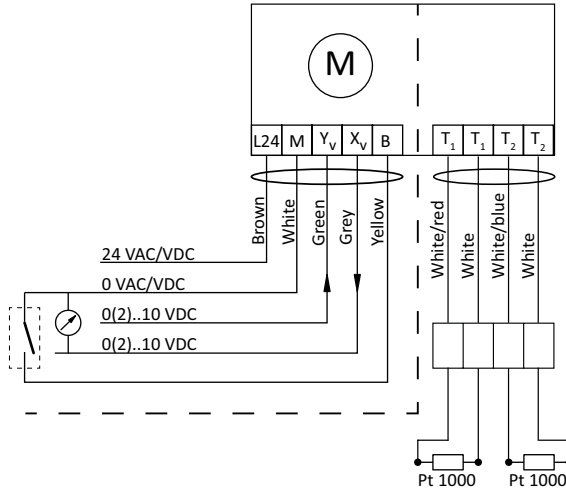
TA-Slider 500 T

TA-Slider 500 2T

Terminal	Description
L24	Power supply 24 VAC/VDC
M	Neutral for power supply 24 VAC/VDC and signals.
Y_v	Input signal for proportional control 0(2)-10 VDC, 47 k Ω
X_v	Output signal 0(2)-10 VDC, max. 8 mA or min. load resistance 1.25 k Ω
B	Connection for potential free contact (e.g. open window detection), max. 100 Ω , max. 10 m cable or shielded
T1	Connection to first Pt1000 temperature sensor, max. 10 m total cable length between actuator and sensor head.
T2	Connection to second Pt1000 temperature sensor, max. 10 m total cable length between actuator and sensor head.

T1/T2: Required configuration via HyTune App for 2T version. Temperature sensors must be enabled within ancillary inputs/ outputs section of the control settings menu. For T version, the built-in temperature sensor is enabled by default.



24 VAC/VDC operating only with safety transformer according to EN 61558-2-6.

Sensors

For applications that require only one temperature measurement, the T version is suitable, as it comes equipped with an integrated sensor. **No additional temperature sensors are necessary.**

For applications where two temperature measurements are necessary, order the 2T version along with two temperature sensors. IMI offers a range of temperature sensors that are compatible with the actuator. Note that the sensors do not have to be of the same type. For article numbers see section "Sensors".

Insertion in temperature pocket

Sensor type: Pt1000, Ø 5 mm, 3 m cable.

Pocket length [mm]	Cable length [mm]	For pipe DN			
		10-25	32-50	65-80	100-250
25	3000	X			
40	3000		X		
70	3000			X	
100	3000				X

Insertion in valve measuring point

Sensor type: Pt1000, Ø 3 mm, 3 or 5 m cable.

Sensor length [mm]	Cable length [mm]	TA-Modulator DN 10-50	TBV-CM DN 15-25	TA-COMPACT -P/-DP DN 10-32	STAD DN 10-50	STAF/ STAF-SG DN 65-125	STAF/ STAF-SG DN 150	STAF-SG DN 200-250	STAF-SG DN 300-400
60	3000	X	X	X	X				
130	5000					X		X	
170	5000						X		X

Surface mounted temperature sensor

Sensor type: Pt1000, 3 m cable.

Examples

TA-Modulator with 2T version

In this setup, 2 sensors should be ordered. One sensor is used for insertion in a measuring point, and another sensor is inserted into a temperature pocket.

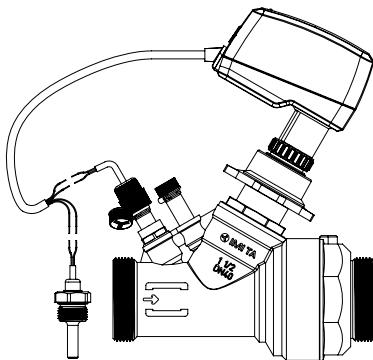

TA-Modulator with 2T version and STAD

In this setup, 2 sensors should be ordered. One sensor is used for measuring point in TA-Modulator, and another sensor is inserted into the measuring point from STAD.

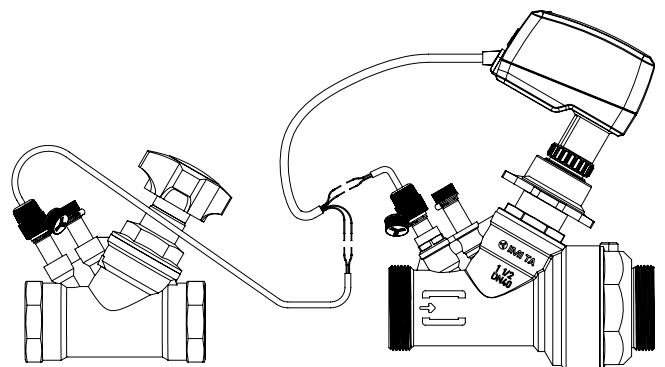

Articles

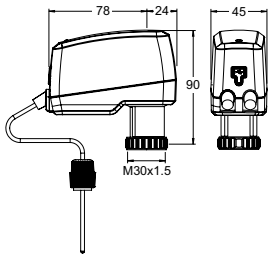

TA-Slider 500 T

Pre-mounted Pt1000 for valve measuring point insertion.
Input signal: 0(2)-10 VDC

Cable length	Sensor cable length	Supply voltage	EAN	Article No
1000	160	24 VAC/VDC	5902276820892	322225-10814
2000	160	24 VAC/VDC	5902276820908	322225-10815
5000	160	24 VAC/VDC	5902276820915	322225-10816

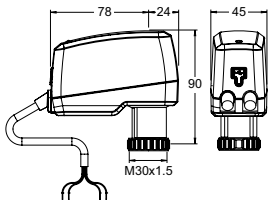

TA-Slider 500 2T

Without pre-mounted Pt1000. Sensors ordered separately.
Input signal: 0(2)-10 VDC

Cable length	Sensor cable length	Supply voltage	EAN	Article No
1000	1000	24 VAC/VDC	5902276820922	322225-10914
2000	1000	24 VAC/VDC	5902276820939	322225-10915
5000	1000	24 VAC/VDC	5902276820946	322225-10916

Sensors

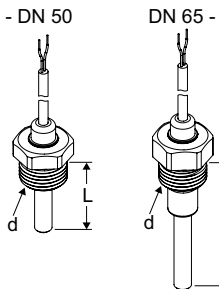

Temperature pocket with sensor

Pt1000

For mounting directly on pipe.

Free space >70 mm is required above the temperature sensor pocket.

For pipe DN	d	L	Cable length	EAN	Article No
10-25	G1/2	25	3000	5902276820748	322428-00020
32-50	G1/2	40	3000	5902276820755	322428-00521
65-80	G1/2	70	3000	5902276821745	322428-00621
100-250	G1/2	100	3000	5902276821738	322428-00721

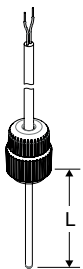

Temperature sensor for valve measuring point

Pt1000

Applicable to families: TA-Modulator, TBV-CM, TA-COMPACT-P/-DP, STAD, STAF/STAF-SG

For valve DN	L	Cable length	EAN	Article No
10-50	60	3000	5902276820786	322428-00122
65-250	130	5000	5902276820793	322428-00134
300-400 + STAF 150	170	5000	5902276820809	322428-00135

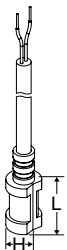

Surface temperature sensor

Pt1000

For mounting directly on pipe surface.

H	L	Cable length	EAN	Article No
10	16	3000	5902276820816	322428-00429

Additional equipment

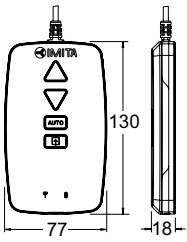

TA-Dongle

For Bluetooth communication with the HyTune app, transfer configuration settings and manual override.

EAN	Article No
5901688828632	322228-00001

Accessories

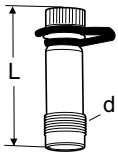

Measuring point

AMETAL®/EPDM

For mounting directly on pipe and insertion of Temperature sensor for valve measuring point.

d	L	EAN	Article No
R1/4	39	7318792813108	52 179-009
R1/4	103	7318792814600	52 179-609
R3/8	45	7318792813009	52 179-008
R3/8	101	7318792814501	52 179-608



The products, texts, photographs, graphics and diagrams in this document may be subject to alteration by IMI without prior notice or reasons being given. For the most up to date information about our products and specifications, please visit climatecontrol.imiplc.com.