

Climate
Control

IMI TA

TA-PILOT-R



Differential pressure controllers

Pilot operated differential pressure controller with adjustable set-point

TA-PILOT-R

The TA-PILOT-R is a high performing differential pressure controller designed to keep a stable differential pressure over the load. With unrivaled accuracy TA-PILOT-R assists in delivering accurate and stable conditions to provide superior control valve authority for modulating control valves, additionally it can limit noise and simplify the balancing procedure. TA-PILOT-R is a differential pressure controller for use in return pipes. Measuring points enable pressure measurements for diagnostics.

Key features

Easy handling and installation

Very low weight and small overall proportions.

Precise and stable differential pressure control

Unrivaled accuracy thanks to the new PILOT technology.

Measuring and system diagnostics

Unique features to validate and better understand system behaviour to minimize energy consumption.



Technical description

Application:

Heating and cooling systems.
Installation in the return pipe.

Functions:

Differential pressure control
Pre-setting Δp over the load (Δp_L)
Measuring (Δp_L)

Dimensions:

DN 65-200

Pressure class:

PN 16 and PN 25

Max. differential pressure (Δp_V):

1200 kPa

Setting range:

10* - 50 kPa
30* - 150 kPa
80* - 400 kPa
*) Delivery settings

Leakage rate:

Tight sealing

Temperature:

Max. working temperature:
- with measuring points, standard:
120°C
- with measuring points, double secured:
150°C
Min. working temperature: -10°C

Media:

Water or neutral fluids, water-glycol mixtures (0-57%).

Material:

Valve body: Ductile iron EN-GJS-400-15
Pilot extension body: Brass
Pilot body: AMETAL®
O-rings: EDPM rubber
Seat seal: EPDM/Stainless steel
Plug mechanism: Stainless steel and brass
Membrane: EPDM rubber
Springs: Stainless steel
Screws and nuts: Stainless steel

AMETAL® is the dezincification resistant alloy of IMI.

Surface treatment:

Pilot body: Non treated
Valve body: Electrophoretic painting.

Marking:

IMI TA, IMI, DN, PN, Kvs, $T_{min/max}$, serial number, valve body material and flow direction arrow, label, Δp_L range.
Colour identification on top of the pilot:
10-50 kPa: Blue
30-150 kPa: Orange
80-400 kPa: Grey
CE-marking:
DN 65-200, PN 16: CE
DN 65-125, PN 25: CE
DN 150-200, PN 25: CE 0409 *

*) Notified body.

Flanges:

PN 16, PN 25: According to EN-1092-2, type 21.
Face to face length according to EN 558 series 3.

Working range

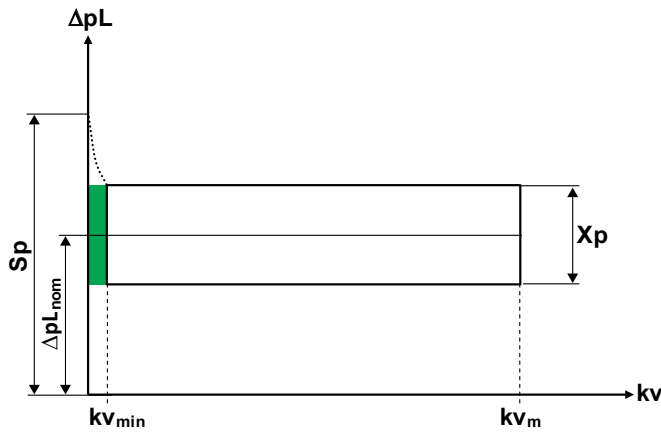

Sp = Sealing pressure, the increase of ΔpL in kPa when a Δp controller controls ΔpL from Kv_{min} down to zero flow.
 Kv_{min} = m^3/h at a pressure drop of 1 bar and minimum opening corresponding to the p-band.
 Kv_m = m^3/h at a pressure drop of 1 bar and maximum opening corresponding to the p-band.
 q_{max} = The maximum recommended flow through a Δp controller.
 ΔpL_{nom} = Middle value of ΔpL in the p-band.
 Xp = The p-band in kPa for ΔpL .
 ΔH = Available differential pressure.
 Δp = Pressure drop across the valve.
 q = Actual measured flow.

DN		65	80	100	125	150	200	
Sp [kPa]	$\Delta H = 0-400$ kPa					45		
	$\Delta H = 400-1200$ kPa					65		
Kv_{min}						4		
Kv_m		75	110	180	270	400	600	
q_{max} [m^3/h]		53	78	127	191	283	424	

NOTE: Below Kv_{min} use expansion vessel for stable control. If Sp is within the p-band, the p-band is valid down to $Kv = 0$.

Maximum p-band in $\pm\%$ of ΔpL_{nom}

Setting range
 10-50 / 30-150 kPa

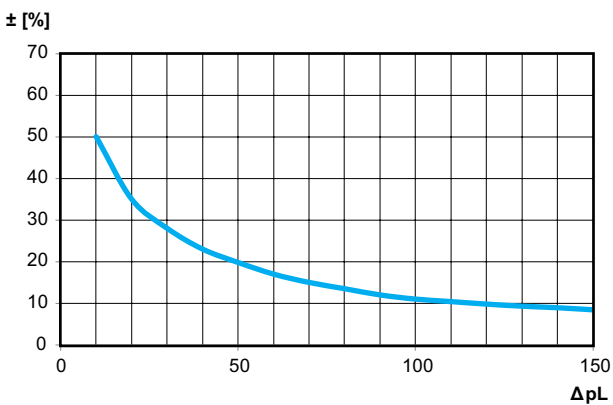

80-400 kPa

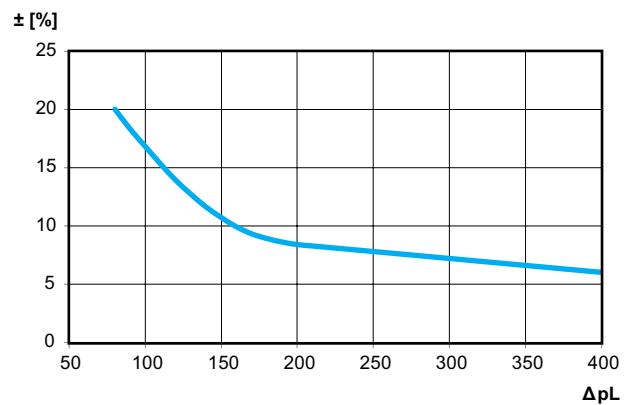

Noise

In order to avoid noise in the installation, the valve must be correctly installed and the water de-aerated.

Sizing

The diagram shows the lowest pressure drop required for the TA-PILOT-R valve to be within its working range at different flows.

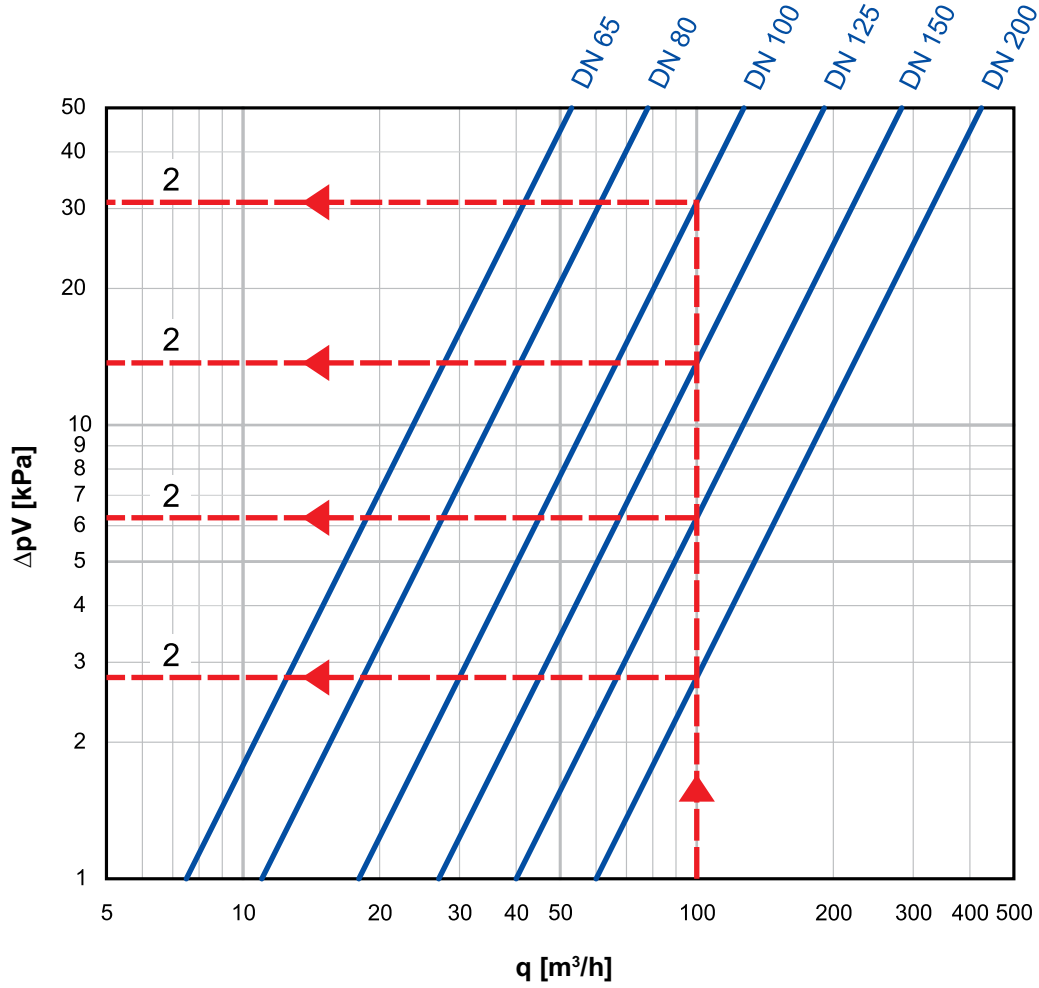

Example

Design flow 100 m³/h, ΔpL = 60 kPa and available differential pressure ΔH = 80 kPa.

1. Design flow (q) 100 m³/h.
2. Read the minimum needed pressure drop for TA-PILOT-R ΔpV_{min} from the diagram.
 - DN 100 ΔpV_{min} = 31 kPa
 - DN 125 ΔpV_{min} = 14 kPa
 - DN 150 ΔpV_{min} = 6 kPa
 - DN 200 ΔpV_{min} = 2,8 kPa
3. Check that the ΔpL is within the setting range for these sizes.
4. Calculate the minimum needed available differential pressure ΔH_{min}.
 - Pressure drop over fully open STAF and 100 m³/h, DN 100 = 28 kPa, DN 125 = 11 kPa, DN 150 = 6 kPa and DN 200 = 2 kPa.

$$\Delta H_{min} = \Delta pV_{STAF} + \Delta pL + \Delta pV_{min}$$

- DN 100: ΔH_{min} = 28 + 60 + 31 = 119 kPa
- DN 125: ΔH_{min} = 11 + 60 + 14 = 85 kPa
- DN 150: ΔH_{min} = 6 + 60 + 6 = 72 kPa
- DN 200: ΔH_{min} = 2 + 60 + 2,8 = 64,8 kPa

5. In order to optimise the control function of the TA-PILOT-R select the smallest possible valve, in this case DN 150. (DN 100 and DN 125 are not suitable since ΔH_{min} = 119 and 85 kPa and the available differential pressure only 80 kPa.)

When to use expansion vessel

Example

Given:

Minimum flow q_{min} = 6 m³/h

Design pressure drop of the load ΔpL = 200 kPa

Available differential pressure at minimum flow ΔH_{max} = 300 kPa

1. Calculate Kv_{min} for q_{min} at ΔH_{max}.

$$Kv_{min} = 10 \cdot q_{min} / \sqrt{(\Delta H_{max} - \Delta pL)}$$

$$Kv_{min} = 10 \cdot 6 / \sqrt{(300-200)} = 6$$

Kv_{min} is **above 4**.

Expansion vessel is **not** needed.

$$Kv = 10 \cdot \frac{q}{\sqrt{\Delta p}} \quad (q \text{ [m}^3\text{/h]}; \Delta p \text{ [kPa]})$$

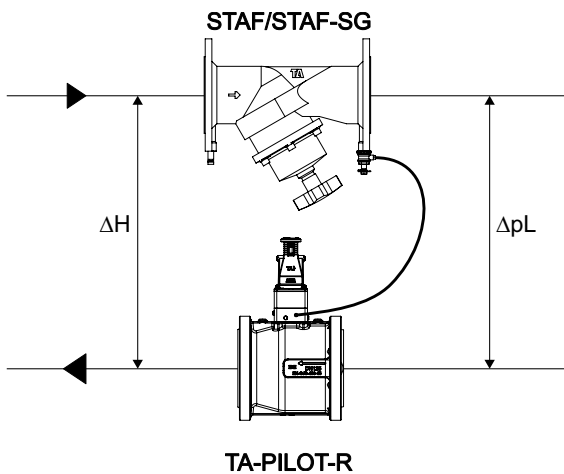

IMI recommends the software HySelect for calculating the valve size. HySelect can be downloaded from climatecontrol.imiplc.com.

Installation

Application examples

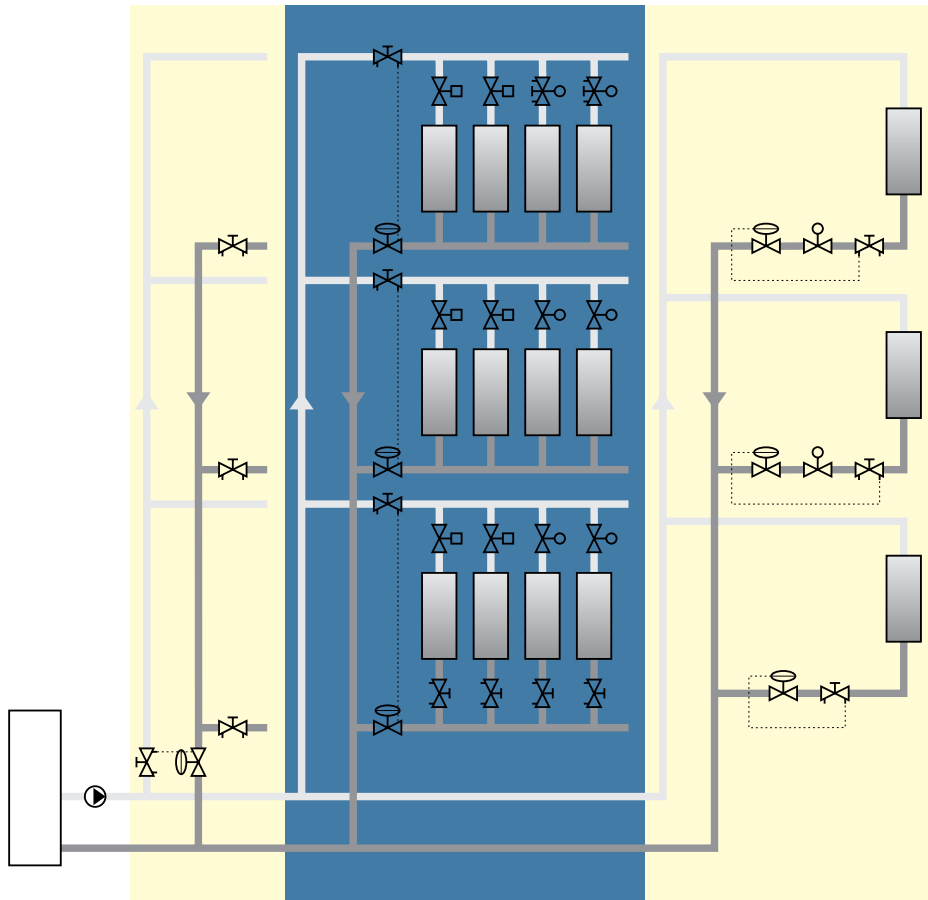

Installation of valve

Approx. 140 mm free space is required above the pilot.

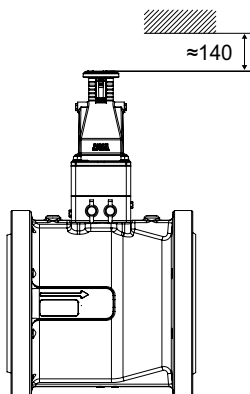

Flow direction

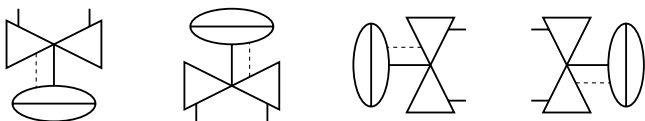
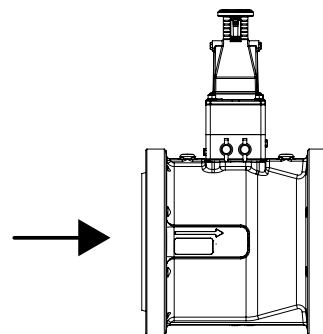

Operating function

Setting

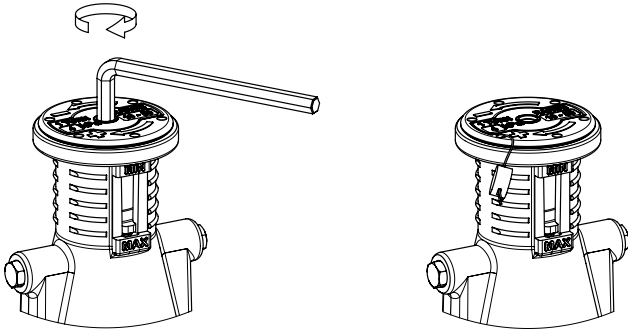

1. Use a 5 mm allen key for setting. Turn clockwise to increase the setting, see table "Setting table" and "kPa/turn". Each rib on the pilot correspond to the different settings in the "Setting table".
2. Tamper proof the setting if necessary.

Setting table

	↺ ↻	[kPa]		
		10-50	30-150	80-400
MIN	0	10*	30*	80*
-	2,5	20	60	160
-	5	30	90	240
-	7,5	40	120	320
MAX	10	50	150	400

*) Delivery setting.

kPa/turn

10-50	30-150	80-400
4 kPa	12 kPa	32 kPa

kPa/turn is also marked on the top of the pilot.

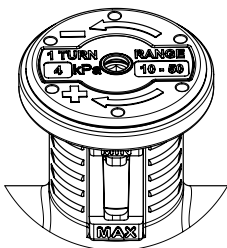

Venting

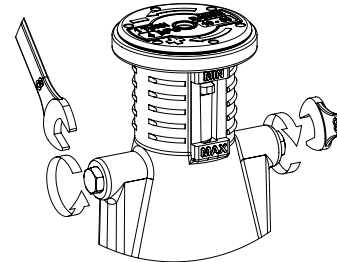

To vent the valve, open the topmost venting screw.
NOTE! Max. 2 turns opening.

Measuring Δp_L

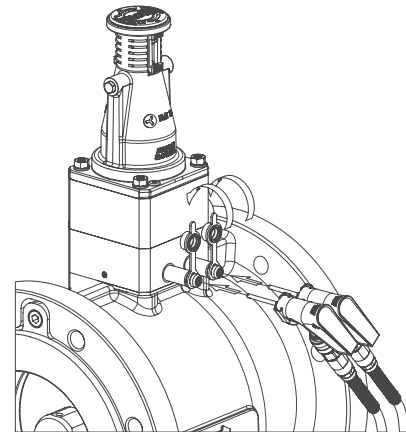

Connect IMI TA balancing instrument to the measuring points and measure Δp_L .

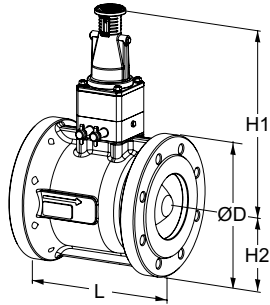
Articles – Max. 120°C

Flanged

Flanges according to EN-1092-2, type 21.

1,2 m capillary pipe (Ø6 mm), capillary pipe connection Ø6xR1/4 (separate part) + Ø6xR1/8 (mounted on valve) and capillary pipe connection with shut-off Ø6xG3/8 are included.

PN 16

DN	Number of bolt holes	ØD	L	H1	H2	Kv _m	q _{max} [m³/h]	Kg	EAN	Article No
10-50 kPa										
65	4	185	190	274	93	75	53	18	3831112530140	23121-2111-065
80	8	200	203	281	100	110	78	21	3831112530232	23121-2111-080
100	8	220	229	303	110	180	127	32	3831112530508	23121-2111-100
125	8	250	254	313	125	270	191	42	3831112530591	23121-2111-125
150	8	285	267	331	143	400	283	55	3831112530690	23121-2111-150
200	12	340	292	361	170	600	424	84	3831112530782	23121-2111-200
30-150 kPa										
65	4	185	190	274	93	75	53	18	3831112530157	23121-2121-065
80	8	200	203	281	100	110	78	21	3831112530249	23121-2121-080
100	8	220	229	303	110	180	127	32	3831112530515	23121-2121-100
125	8	250	254	313	125	270	191	42	3831112530607	23121-2121-125
150	8	285	267	331	143	400	283	55	3831112530706	23121-2121-150
200	12	340	292	361	170	600	424	84	3831112530935	23121-2121-200
80-400 kPa										
65	4	185	190	274	93	75	53	18	3831112530164	23121-2131-065
80	8	200	203	281	100	110	78	21	3831112530256	23121-2131-080
100	8	220	229	303	110	180	127	32	3831112530522	23121-2131-100
125	8	250	254	313	125	270	191	42	3831112530614	23121-2131-125
150	8	285	267	331	143	400	283	55	3831112530713	23121-2131-150
200	12	340	292	361	170	600	424	84	3831112530942	23121-2131-200

PN 25

DN	Number of bolt holes	ØD	L	H1	H2	Kv _m	q _{max} [m³/h]	Kg	EAN	Article No
10-50 kPa										
65	8	185	190	274	93	75	53	18	3831112530171	23121-2211-065
80	8	200	203	281	100	110	78	21	3831112530263	23121-2211-080
100	8	235	229	303	118	180	127	34	3831112530539	23121-2211-100
125	8	270	254	313	135	270	191	45	3831112530621	23121-2211-125
150	8	300	267	331	150	400	283	57	3831112530720	23121-2211-150
200	12	360	292	361	180	600	424	88	3831112530959	23121-2211-200
30-150 kPa										
65	8	185	190	274	93	75	53	18	3831112530195	23121-2221-065
80	8	200	203	281	100	110	78	21	3831112530270	23121-2221-080
100	8	235	229	303	118	180	127	34	3831112530546	23121-2221-100
125	8	270	254	313	135	270	191	45	3831112530638	23121-2221-125
150	8	300	267	331	150	400	283	57	3831112530737	23121-2221-150
200	12	360	292	361	180	600	424	88	3831112530966	23121-2221-200
80-400 kPa										
65	8	185	190	274	93	75	53	18	3831112530188	23121-2231-065
80	8	200	203	281	100	110	78	21	3831112530287	23121-2231-080
100	8	235	229	303	118	180	127	34	3831112530553	23121-2231-100
125	8	270	254	313	135	270	191	45	3831112530645	23121-2231-125
150	8	300	267	331	150	400	283	57	3831112530744	23121-2231-150
200	12	360	292	361	180	600	424	88	3831112530973	23121-2231-200

 Kv_m = m³/h at a pressure drop of 1 bar and maximum opening corresponding to the p-band.

Articles – Max. 150°C (double secured measuring points)

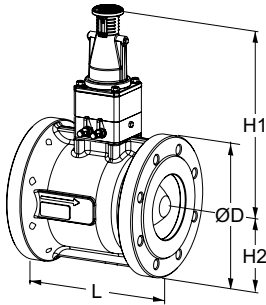

Flanged

Flanges according to EN-1092-2, type 21.

1,2 m capillary pipe (Ø6 mm), capillary pipe connection Ø6xR1/4 (separate part) + Ø6xR1/8 (mounted on valve) and capillary pipe connection with shut-off Ø6xG3/8 are included.

PN 16

DN	Number of bolt holes	ØD	L	H1	H2	Kv _m	q _{max} [m ³ /h]	Kg	EAN	Article No
10-50 kPa										
65	4	185	190	274	93	75	53	18	3831112531017	23121-2112-065
80	8	200	203	281	100	110	78	21	3831112531109	23121-2112-080
100	8	220	229	303	110	180	127	32	3831112531192	23121-2112-100
125	8	250	254	313	125	270	191	42	3831112531284	23121-2112-125
150	8	285	267	331	143	400	283	55	3831112531376	23121-2112-150
200	12	340	292	361	170	600	424	84	3831112531468	23121-2112-200
30-150 kPa										
65	4	185	190	274	93	75	53	18	3831112531024	23121-2122-065
80	8	200	203	281	100	110	78	21	3831112531116	23121-2122-080
100	8	220	229	303	110	180	127	32	3831112531208	23121-2122-100
125	8	250	254	313	125	270	191	42	3831112531291	23121-2122-125
150	8	285	267	331	143	400	283	55	3831112531383	23121-2122-150
200	12	340	292	361	170	600	424	84	3831112531475	23121-2122-200
80-400 kPa										
65	4	185	190	274	93	75	53	18	3831112531031	23121-2132-065
80	8	200	203	281	100	110	78	21	3831112531123	23121-2132-080
100	8	220	229	303	110	180	127	32	3831112531277	23121-2132-100
125	8	250	254	313	125	270	191	42	3831112531307	23121-2132-125
150	8	285	267	331	143	400	283	55	3831112531390	23121-2132-150
200	12	340	292	361	170	600	424	84	3831112531482	23121-2132-200

PN 25

DN	Number of bolt holes	ØD	L	H1	H2	Kv _m	q _{max} [m ³ /h]	Kg	EAN	Article No
10-50 kPa										
65	8	185	190	274	93	75	53	18	3831112531055	23121-2212-065
80	8	200	203	281	100	110	78	21	3831112531130	23121-2212-080
100	8	235	229	303	118	180	127	34	3831112531215	23121-2212-100
125	8	270	254	313	135	270	191	45	3831112531314	23121-2212-125
150	8	300	267	331	150	400	283	57	3831112531406	23121-2212-150
200	12	360	292	361	180	600	424	88	3831112531499	23121-2212-200
30-150 kPa										
65	8	185	190	274	93	75	53	18	3831112531048	23121-2222-065
80	8	200	203	281	100	110	78	21	3831112531147	23121-2222-080
100	8	235	229	303	118	180	127	34	3831112531222	23121-2222-100
125	8	270	254	313	135	270	191	45	3831112531321	23121-2222-125
150	8	300	267	331	150	400	283	57	3831112531413	23121-2222-150
200	12	360	292	361	180	600	424	88	3831112531505	23121-2222-200
80-400 kPa										
65	8	185	190	274	93	75	53	18	3831112531062	23121-2232-065
80	8	200	203	281	100	110	78	21	3831112531161	23121-2232-080
100	8	235	229	303	118	180	127	34	3831112531239	23121-2232-100
125	8	270	254	313	135	270	191	45	3831112531338	23121-2232-125
150	8	300	267	331	150	400	283	57	3831112531420	23121-2232-150
200	12	360	292	361	180	600	424	88	3831112531512	23121-2232-200

Kv_m = m³/h at a pressure drop of 1 bar and maximum opening corresponding to the p-band.

Additional equipment

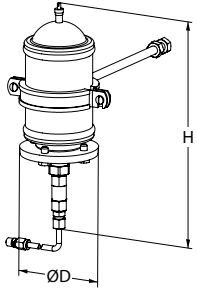

Expansion vessel

For working area less than $K_v = 4$.
 1,2 m capillary pipe (Ø6 mm), capillary pipe connection Ø6xR1/4 and capillary pipe connection with shut-off Ø6xG3/8 are included.
 Factory set at 3 bar.

H	D	EAN	Article No
266	90	3831112532052	23124-2542-001

Accessories

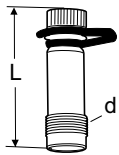

Measuring point

Max 120°C (intermittent 150°C)
 AMETAL®/EPDM

d	L	EAN	Article No
M14x1	44	7318792813207	52 179-014
M14x1	103	7318793858108	52 179-015

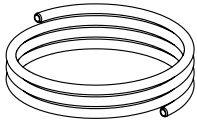

Capillary pipe

Ø6 mm
 1 pc included in TA-PILOT-R.

L [m]	EAN	Article No
1,2	3831112527157	52 759-215

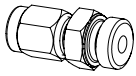

Capillary pipe connection

For capillary pipe Ø6 mm with R1/4 or R1/8 connection.
 1 pc 6xR1/4 included in TA-PILOT-R as a separate part. (Ø6xR1/8 mounted on valve).

	EAN	Article No
6xR1/4	3831112527355	52 759-201
6xR1/8	3831112533868	52 759-213

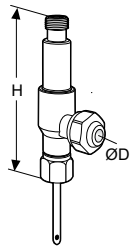

Measuring point, two-way

For connection of capillary pipe while permitting simultaneous use of our balancing instrument.
 For connection to existing measuring point on STAF/STAF-SG.
 Can be installed during operation.

D	H	EAN	Article No
6	68	7318793848703	52 179-206



Measuring point, extension 60 mm

Can be installed without draining of the system.
 AMETAL®/Stainless steel/EPDM

L	EAN	Article No
60	7318792812804	52 179-006

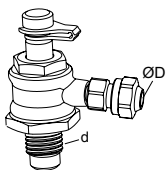

Capillary pipe connection with shut-off

For replacement of existing measuring point on STAF/STAF-SG.
 1 pc G3/8 included in TA-PILOT-R.

d	D	For DN	EAN	Article No
G1/4	6	20-50	7318793999504	52 265-209
G3/8	6	65-400	7318793999405	52 265-208

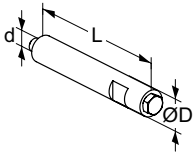

Venting extension
 Suitable when insulation is used.
 Stainless steel/EPDM/Brass.

d	D	L	EAN	Article No
M6	12	70	3831112531727	52 759-220

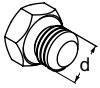

Venting screw
 Brass/EPDM

d	EAN	Article No
M6	3831112527980	52 759-211



The products, texts, photographs, graphics and diagrams in this document may be subject to alteration by IMI without prior notice or reasons being given. For the most up to date information about our products and specifications, please visit climatecontrol.imiplc.com.