

TYPE 800 CAST STAINLESS STEEL BALL VALVE SCREWED ENDS

KITZ Fig: UTHM

Sizes: 1/2-2inch(15-50mm)

REDUCED BORE

Standards

. End to End: KITZ STANDARD

. End Connection: JIS B0203

. Wall Thickness: KITZ STANDARD

Test Standard

. KITZ STANDARD

Approvals

Japan Valve Manufacturer's Association 15-50 mm (1/2-2 inch)

Conform to

RoHS 15-50 mm (1/2-2 inch)

approved

Dimensions

SIZE (inch/mm)	L	L1	H	D1	Kg	
1/2	15	60.0	0.0	47.0	100.0	0.00
3/4	20	70.0	0.0	53.0	100.0	0.00
1	25	80.0	0.0	63.0	130.0	0.00
1 1/4	32	95.0	0.0	67.0	130.0	0.00
1 1/2	40	108.0	0.0	79.0	150.0	0.00
2	50	124.0	0.0	85.0	150.0	0.00

Material List

NAME OF PART	MATERIAL	SPECIFICATION
BODY	STAINLESS STEEL	A351 Gr. CF8M/SCS14A
BODY CAP	STAINLESS STEEL	A351 Gr. CF8M/SCS14A
STEM	STAINLESS STEEL	316SS
BALL	STAINLESS STEEL	316SS

Specifications

TYPE 800 CAST STAINLESS STEEL BALL VALVE SCREWED ENDS, REDUCED BORE

End to End : KITZ STANDARD, End Connection : JIS B0203, Wall Thickness : KITZ STANDARD, Test Standard : KITZ STANDARD, Sizes :

1/2-2inch(15-50mm), Approvals : Japan Valve Manufacturer's Association 15-50 mm (1/2-2 inch), Conform to : RoHS 15-50 mm

(1/2-2 inch), BODY MATERIAL : STAINLESS STEEL, BODY CAP MATERIAL

: STAINLESS STEEL, STEM MATERIAL : STAINLESS STEEL, BALL MATERIAL

: STAINLESS STEEL, KITZ Fig : UTHM



JV  RoHS

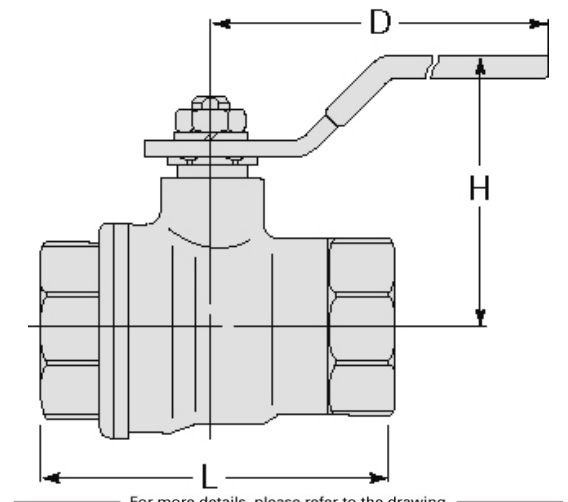

For more details, please refer to the drawing.

Pressure-temperature ratings and other performance data published in this catalog have been developed from our design calculation, in-house testing, field reports provided by our customers and/or published official standards or specifications. They are good only to cover typical applications as a general guideline to users of KITZ products introduced in this catalog. For any specific application, users are kindly requested to contact KITZ Corporation for technical advice, or to carry out their own study and evaluation for proving suitability of these products to such an application. Failure to follow this request could result in property damage and/or personal injury, for which we shall not be liable. Read instruction manual carefully before use.

KITZ

KITZ CORPORATION Tokyo Shiodome Building, 1-9-1, Higashi-Shimbashi, Minato-ku, Tokyo 105-7305, Japan
© KITZ Corporation. All Right Reserved.

ISO 9001
CERTIFIED
Since 1989

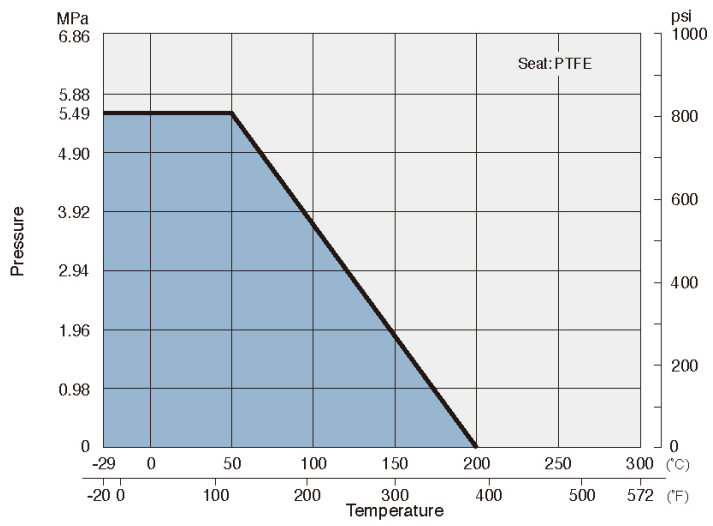

Pressure-temperature ratings and other performance data published in this catalog have been developed from our design calculation, in-house testing, field reports provided by our customers and/or published official standards or specifications. They are good only to cover typical applications as a general guideline to users of KITZ products introduced in this catalog. For any specific application, users are kindly requested to contact KITZ Corporation for technical advice, or to carry out their own study and evaluation for proving suitability of these products to such an application. Failure to follow this request could result in property damage and/or personal injury, for which we shall not be liable. Read instruction manual carefully before use.



KITZ CORPORATION Tokyo Shiodome Building, 1-9-1, Higashi-Shimbashi, Minato-ku, Tokyo 105-7305, Japan
© KITZ Corporation. All Right Reserved.

