

10K DUCTILE IRON BALL VALVES, WITH ELECTRIC ACTUATOR

KITZ Fig: EXH200-10STBF

Sizes: 1/2-8inch(15-200mm)

FULL BORE, FLANGED ENDS.

Standards

. End to End: ASME B16.10 CLASS 150

. End Connection: JIS B2239 10K

. Wall Thickness: KITZ STANDARD

Test Standard

. KITZ STANDARD

Dimensions

SIZE (inch/mm)	L	L1	H	D1	Kg
1/2	15	108.0	41.0	287.0	0.00
3/4	20	117.0	45.0	290.0	0.00
1	25	127.0	46.0	298.0	0.00
1 1/4	32	140.0	56.0	301.0	0.00
1 1/2	40	165.0	67.0	332.0	0.00
2	50	178.0	74.0	339.0	0.00
2 1/2	65	190.0	85.0	409.5	0.00
3	80	203.0	95.0	418.5	0.00
4	100	229.0	110.0	441.5	0.00
5	125	356.0	178.0	551.0	0.00
6	150	394.0	197.0	576.0	0.00
8	200	457.0	228.5	630.0	0.00

Material List

NAME OF PART	MATERIAL	SPECIFICATION
BODY	DUCTILE IRON	FCD-S
BODY CAP	DUCTILE IRON	FCD-S
STEM	STAINLESS STEEL	403SS
BALL	STAINLESS STEEL	304SS

Specifications

10K DUCTILE IRON BALL VALVES, WITH ELECTRIC ACTUATOR, FULL BORE, FLANGED ENDS.

End to End : ASME B16.10 CLASS 150, End Connection : JIS B2239

10K, Wall Thickness : KITZ STANDARD, Test Standard : KITZ

STANDARD, Sizes : 1/2-8inch(15-200mm), BODY MATERIAL : DUCTILE

IRON, BODY CAP MATERIAL : DUCTILE IRON, STEM MATERIAL : STAINLESS

STEEL, BALL MATERIAL : STAINLESS STEEL, KITZ Fig : EXH200-10STBF

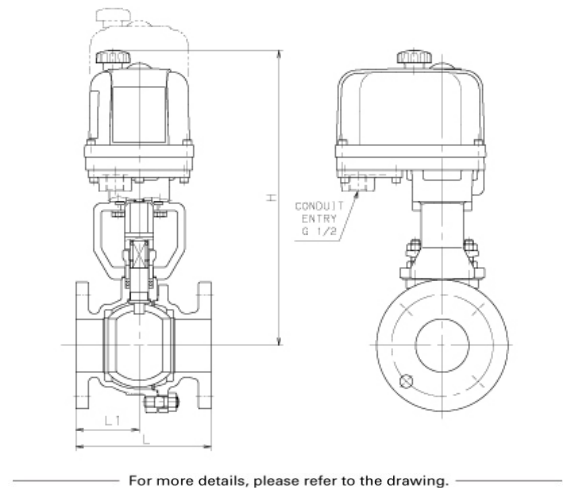

Pressure-temperature ratings and other performance data published in this catalog have been developed from our design calculation, in-house testing, field reports provided by our customers and/or published official standards or specifications. They are good only to cover typical applications as a general guideline to users of KITZ products introduced in this catalog. For any specific application, users are kindly requested to contact KITZ Corporation for technical advice, or to carry out their own study and evaluation for proving suitability of these products to such an application. Failure to follow this request could result in property damage and/or personal injury, for which we shall not be liable. Read instruction manual carefully before use.

KITZ

KITZ CORPORATION Tokyo Shiodome Building, 1-9-1, Higashi-Shimbashi, Minato-ku, Tokyo 105-7305, Japan
© KITZ Corporation. All Right Reserved.

ISO 9001
CERTIFIED
Since 1989