

10K CAST STAINLESS STEEL BALL VALVE FLANGED ENDS WITH PNEUMATIC ACTUATOR

KITZ Fig: B-10UTBM

Sizes: 1/2-10inch(15-250mm)

ANTI-STATIC DEVICE, FULL BORE, DOUBLE ACTING TYPE

Standards

. End to End: KITZ STANDARD

. End Connection: JIS B2220 10K

. Wall Thickness: ASME B16.34 CLASS 150

Test Standard

. KITZ STANDARD

Dimensions

SIZE (inch/mm)	L	L1	H	D1	Kg
1/2 15	110.0	42.0	211.0	0.0	0.00
3/4 20	120.0	47.0	214.0	0.0	0.00
1 25	130.0	50.0	221.0	0.0	0.00
1 1/4 32	140.0	56.0	298.0	0.0	0.00
1 1/2 40	165.0	67.0	318.0	0.0	0.00
2 50	180.0	74.0	365.0	0.0	0.00
2 1/2 65	190.0	85.0	390.0	0.0	0.00
3 80	200.0	95.0	464.0	0.0	0.00
4 100	230.0	110.0	488.0	0.0	0.00
5 125	300.0	150.0	601.0	0.0	0.00
6 150	340.0	170.0	626.0	0.0	0.00
8 200					
10 250	533.0	266.5	756.0	0.0	0.00

Material List

NAME OF PART	MATERIAL	SPECIFICATION
BODY	STAINLESS STEEL	A351 Gr. CF8M/SCS14A
BODY CAP	STAINLESS STEEL	A351 Gr. CF8M/SCS14A
STEM	STAINLESS STEEL	316SS
BALL	STAINLESS STEEL	A351 Gr. CF8M/SCS14A

Specifications

10K CAST STAINLESS STEEL BALL VALVE FLANGED ENDS WITH PNEUMATIC ACTUATOR, ANTI-STATIC DEVICE, FULL BORE, DOUBLE ACTING TYPE

End to End : KITZ STANDARD, End Connection : JIS B2220 10K, Wall

Thickness : ASME B16.34 CLASS 150, Test Standard : KITZ

STANDARD, Sizes : 1/2-10inch(15-250mm), BODY MATERIAL : STAINLESS

STEEL, BODY CAP MATERIAL : STAINLESS STEEL, STEM MATERIAL : STAINLESS

STEEL, BALL MATERIAL : STAINLESS STEEL, KITZ Fig : B-10UTBM

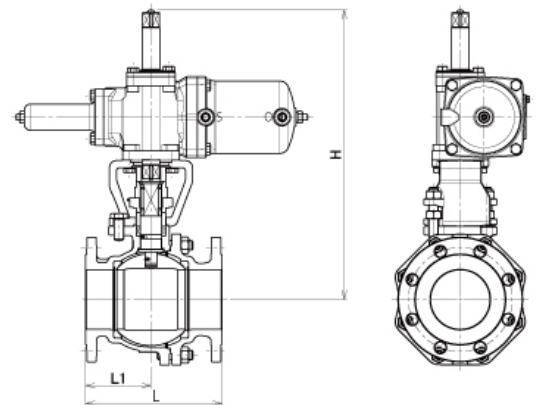

For more details, please refer to the drawing.

Pressure-temperature ratings and other performance data published in this catalog have been developed from our design calculation, in-house testing, field reports provided by our customers and/or published official standards or specifications. They are good only to cover typical applications as a general guideline to users of KITZ products introduced in this catalog. For any specific application, users are kindly requested to contact KITZ Corporation for technical advice, or to carry out their own study and evaluation for proving suitability of these products to such an application. Failure to follow this request could result in property damage and/or personal injury, for which we shall not be liable. Read instruction manual carefully before use.

KITZ

KITZ CORPORATION Tokyo Shiodome Building, 1-9-1, Higashi-Shimbashi, Minato-ku, Tokyo 105-7305, Japan
© KITZ Corporation. All Right Reserved.

ISO 9001
CERTIFIED
Since 1989

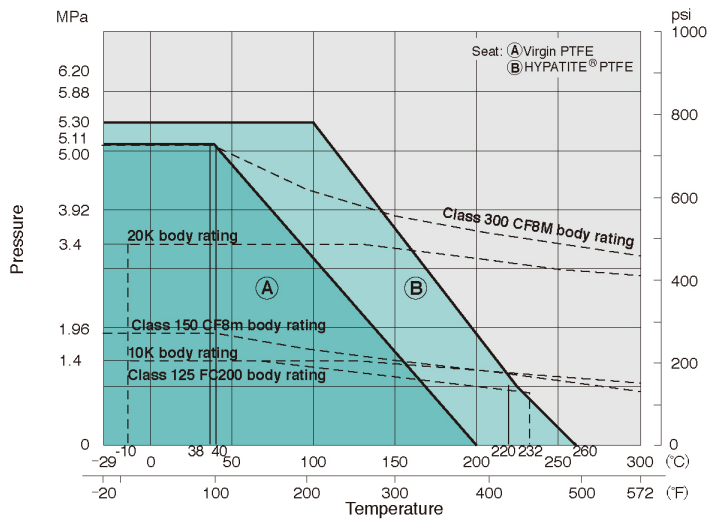

Pressure-temperature ratings and other performance data published in this catalog have been developed from our design calculation, in-house testing, field reports provided by our customers and/or published official standards or specifications. They are good only to cover typical applications as a general guideline to users of KITZ products introduced in this catalog. For any specific application, users are kindly requested to contact KITZ Corporation for technical advice, or to carry out their own study and evaluation for proving suitability of these products to such an application. Failure to follow this request could result in property damage and/or personal injury, for which we shall not be liable. Read instruction manual carefully before use.



KITZ CORPORATION Tokyo Shiodome Building, 1-9-1, Higashi-Shimbashi, Minato-ku, Tokyo 105-7305, Japan
© KITZ Corporation. All Right Reserved.

