

## CLASS 300 CAST STEEL SWING CHECK VALVE FLANGED ENDS

KITZ Fig: 300SCOS

Sizes: 11/2-24inch(40-600mm)

BOLTED COVER

Standards

- End to End: ASME B16.10 CLASS 300
- End Connection: ASME B16.5 CLASS 300
- Wall Thickness: API 600 CLASS 300

Test Standard

- API 598

Dimensions

SIZE (inch/mm)	L	L1	H	D1	Kg
11/2	40	241.0	0.0	155.0	0.00
2	50	267.0	0.0	164.0	0.00
2 1/2	65	292.0	0.0	190.0	0.00
3	80	318.0	0.0	205.0	0.00
4	100	356.0	0.0	230.0	0.00
5	125	400.0	0.0	250.0	0.00
6	150	444.0	0.0	280.0	0.00
8	200	533.0	0.0	330.0	0.00
10	250	622.0	0.0	370.0	0.00
12	300	711.0	0.0	416.0	0.00
14	350	838.0	0.0	497.0	0.00
16	400	864.0	0.0	543.0	0.00
18	450	978.0	0.0	600.0	0.00
20	500	1016.0	0.0	645.0	0.00
24	600	1346.0	0.0	866.0	0.00

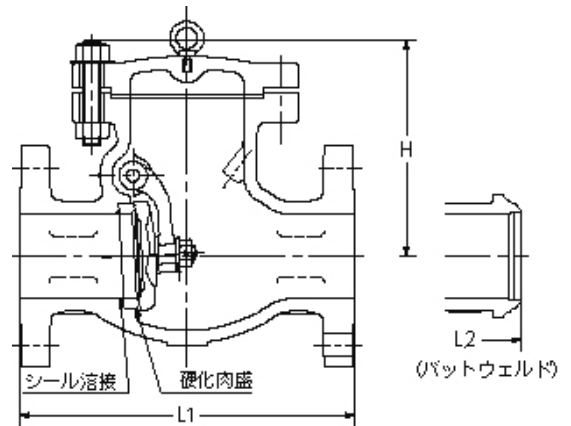

For more details, please refer to the drawing.

### Material List

NAME OF PART	MATERIAL	SPECIFICATION
BODY	CAST STEEL	A216 Gr. WCB/SCPH2
COVER	CAST STEEL	A216 Gr. WCB/SCPH2
DISC	STAINLESS STEEL	A216 Gr. WCB/SCPH2+13Cr

### Specifications

CLASS 300 CAST STEEL SWING CHECK VALVE FLANGED ENDS, BOLTED COVER

End to End : ASME B16.10 CLASS 300, End Connection : ASME B16.5

CLASS 300, Wall Thickness : API 600 CLASS 300, Test Standard : API

598, Sizes : 11/2-24inch(40-600mm), BODY MATERIAL : CAST

STEEL, COVER MATERIAL : CAST STEEL, DISC MATERIAL : STAINLESS STEEL, KITZ

Fig : 300SCOS

Pressure-temperature ratings and other performance data published in this catalog have been developed from our design calculation, in-house testing, field reports provided by our customers and/or published official standards or specifications. They are good only to cover typical applications as a general guideline to users of KITZ products introduced in this catalog. For any specific application, users are kindly requested to contact KITZ Corporation for technical advice, or to carry out their own study and evaluation for proving suitability of these products to such an application. Failure to follow this request could result in property damage and/or personal injury, for which we shall not be liable. Read instruction manual carefully before use.

# KITZ

KITZ CORPORATION Tokyo Shiodome Building, 1-9-1, Higashi-Shimbashi, Minato-ku, Tokyo 105-7305, Japan  
© KITZ Corporation. All Right Reserved.

ISO 9001  
CERTIFIED  
Since 1989