

KITZ Fig: 3000SCTK

Sizes: 1/4-2inch(8-50mm)

Standards

- . End to End:
- . End Connection:
- . Wall Thickness:
- . Test Standard

Dimensions

SIZE (inch/mm)	L	L1	H	D1	Kg
1/4 8					
3/8 10					
1/2 15					
3/4 20					
1 25					
1 1/4 32					
1 1/2 40					
2 50					

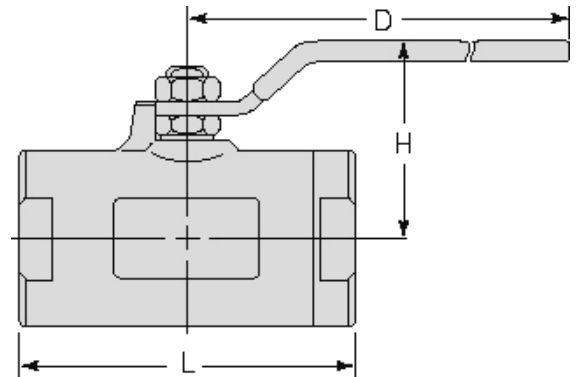

Specifications

Sizes : 1/4-2inch(8-50mm), ,KITZ Fig : 3000SCTK

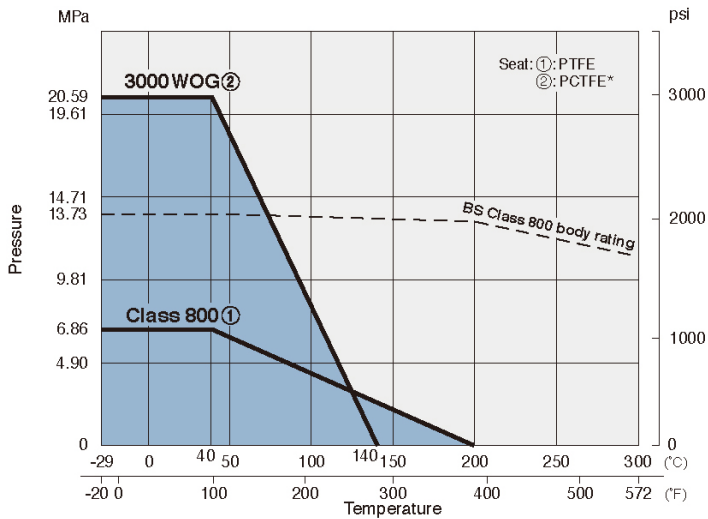

For more details, please refer to the drawing.

Pressure-temperature ratings and other performance data published in this catalog have been developed from our design calculation, in-house testing, field reports provided by our customers and/or published official standards or specifications. They are good only to cover typical applications as a general guideline to users of KITZ products introduced in this catalog. For any specific application, users are kindly requested to contact KITZ Corporation for technical advice, or to carry out their own study and evaluation for proving suitability of these products to such an application. Failure to follow this request could result in property damage and/or personal injury, for which we shall not be liable. Read instruction manual carefully before use.

