

20K CAST STAINLESS STEEL SWING CHECK VALVE FLANGED ENDS

KITZ Fig: 20UOAMT

Sizes: 11/2-14inch(40-350mm)

BOLTED COVER

Standards

- End to End: ASME B16.10 CLASS 300
- End Connection: JIS B2220 20K
- Wall Thickness: ASME B16.34 CLASS 300

Test Standard

- KITZ STANDARD

Approvals

Japan Valve Manufacturer's Association 40-350 mm (11/2-14 inch) approved

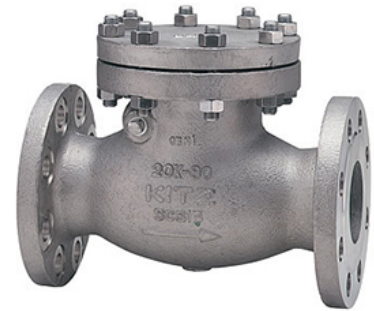

Dimensions

SIZE (inch/mm)	L	L1	H	D1	Kg
11/2 40	241.0	0.0	123.0	0.0	0.00
2 50	267.0	0.0	142.0	0.0	0.00
2 1/2 65	292.0	0.0	165.0	0.0	0.00
3 80	318.0	0.0	180.0	0.0	0.00
4 100	356.0	0.0	203.0	0.0	0.00
5 125	400.0	0.0	234.0	0.0	0.00
6 150	444.0	0.0	259.0	0.0	0.00
8 200	533.0	0.0	298.0	0.0	0.00
10 250	622.0	0.0	356.0	0.0	0.00
12 300	711.0	0.0	373.0	0.0	0.00
14 350					

Material List

NAME OF PART	MATERIAL	SPECIFICATION
BODY	STAINLESS STEEL	A351 Gr. CF8M/SCS14A
COVER	STAINLESS STEEL	A351 Gr. CF8M/SCS14A
DISC	STAINLESS STEEL	A351 Gr. CF8M/SCS14A

Specifications

20K CAST STAINLESS STEEL SWING CHECK VALVE FLANGED ENDS, BOLTED COVER

End to End : ASME B16.10 CLASS 300, End Connection : JIS B2220 20K, Wall Thickness : ASME B16.34 CLASS 300, Test Standard : KITZ STANDARD, Sizes : 11/2-14inch(40-350mm), Approvals : Japan Valve Manufacturer's Association 40-350 mm (11/2-14 inch), BODY MATERIAL : STAINLESS STEEL, COVER MATERIAL : STAINLESS STEEL, DISC MATERIAL : STAINLESS STEEL, KITZ Fig : 20UOAMT

JV

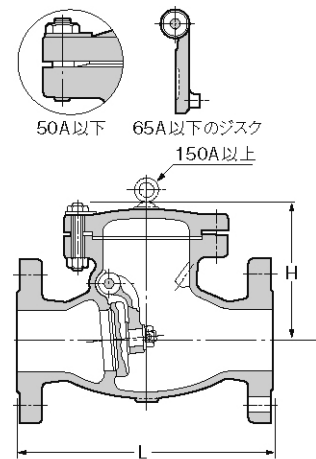

For more details, please refer to the drawing.

Pressure-temperature ratings and other performance data published in this catalog have been developed from our design calculation, in-house testing, field reports provided by our customers and/or published official standards or specifications. They are good only to cover typical applications as a general guideline to users of KITZ products introduced in this catalog. For any specific application, users are kindly requested to contact KITZ Corporation for technical advice, or to carry out their own study and evaluation for proving suitability of these products to such an application. Failure to follow this request could result in property damage and/or personal injury, for which we shall not be liable. Read instruction manual carefully before use.

KITZ

KITZ CORPORATION Tokyo Shiodome Building, 1-9-1, Higashi-Shimbashi, Minato-ku, Tokyo 105-7305, Japan
© KITZ Corporation. All Right Reserved.

ISO 9001
CERTIFIED
Since 1989