

CLASS 150 DUCTILE IRON SWING CHECK VALVE FLANGED ENDS

KITZ Fig: 150SRB

Sizes: 11/2-12inch(40-300mm)

BOLTED COVER.

Standards

- . End to End: ASME B16.10 CLASS 150
- . End Connection: ASME B16.5 CLASS 150
- . Wall Thickness: KITZ STANDARD

Test Standard

- . KITZ STANDARD

Dimensions

SIZE (inch/mm)	L	L1	H	D1	Kg
11/2 40	165.0	0.0	118.0	0.0	0.00
2 50	203.0	0.0	125.0	0.0	0.00
2 1/2 65	216.0	0.0	136.0	0.0	0.00
3 80	241.0	0.0	153.0	0.0	0.00
4 100	292.0	0.0	171.0	0.0	0.00
5 125	330.0	0.0	206.0	0.0	0.00
6 150	356.0	0.0	224.0	0.0	0.00
8 200	495.0	0.0	264.0	0.0	0.00
10 250	622.0	0.0	325.0	0.0	0.00
12 300	698.0	0.0	364.0	0.0	0.00

Material List

NAME OF PART	MATERIAL	SPECIFICATION
BODY	DUCTILE IRON	FCD-S
COVER	DUCTILE IRON	FCD-S
DISC	STAINLESS STEEL	A216 Gr. WCB/SCPH2+13Cr

Specifications

CLASS 150 DUCTILE IRON SWING CHECK VALVE FLANGED ENDS, BOLTED COVER.

End to End : ASME B16.10 CLASS 150, End Connection : ASME B16.5 CLASS 150, Wall Thickness : KITZ STANDARD, Test Standard : KITZ STANDARD, Sizes : 11/2-12inch(40-300mm), BODY MATERIAL : DUCTILE IRON, COVER MATERIAL : DUCTILE IRON, DISC MATERIAL : STAINLESS STEEL, KITZ Fig : 150SRB

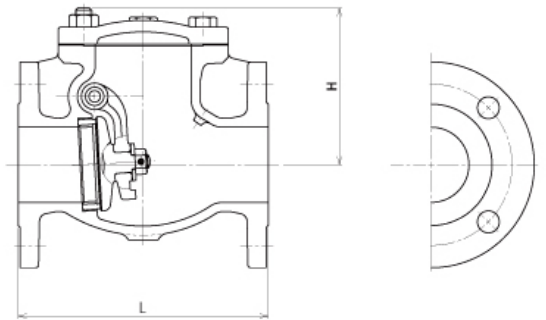

For more details, please refer to the drawing.

Pressure-temperature ratings and other performance data published in this catalog have been developed from our design calculation, in-house testing, field reports provided by our customers and/or published official standards or specifications. They are good only to cover typical applications as a general guideline to users of KITZ products introduced in this catalog. For any specific application, users are kindly requested to contact KITZ Corporation for technical advice, or to carry out their own study and evaluation for proving suitability of these products to such an application. Failure to follow this request could result in property damage and/or personal injury, for which we shall not be liable. Read instruction manual carefully before use.

KITZ

KITZ CORPORATION Tokyo Shiodome Building, 1-9-1, Higashi-Shimbashi, Minato-ku, Tokyo 105-7305, Japan
© KITZ Corporation. All Right Reserved.

ISO 9001
CERTIFIED
Since 1989