

10K CAST STAINLESS STEEL SWING CHECK VALVE FLANGED ENDS

KITZ Fig: 10UOAT

Sizes: 11/2-14inch(40-350mm)

Standards

- End to End: ASME B16.10 CLASS 150
- End Connection: JIS B2220 10K
- Wall Thickness: ASME B16.34 CLASS 150

Test Standard

- KITZ STANDARD

Approvals

Japan Valve Manufacturer's Association 40-350 mm (11/2-14 inch) approved

Dimensions

SIZE (inch/mm)	L	L1	H	D1	Kg
11/2 40	165.0	0.0	109.0	0.0	0.00
2 50	203.0	0.0	119.0	0.0	0.00
2 1/2 65	216.0	0.0	134.0	0.0	0.00
3 80	241.0	0.0	146.0	0.0	0.00
4 100	292.0	0.0	165.0	0.0	0.00
5 125	330.0	0.0	192.0	0.0	0.00
6 150	356.0	0.0	216.0	0.0	0.00
8 200	495.0	0.0	264.0	0.0	0.00
10 250	622.0	0.0	287.0	0.0	0.00
12 300	698.0	0.0	315.0	0.0	0.00
14 350	787.0	0.0	363.0	0.0	0.00

Material List

NAME OF PART	MATERIAL	SPECIFICATION
BODY	STAINLESS STEEL	A351 Gr. CF8/SCS13A
COVER	STAINLESS STEEL	A351 Gr. CF8/SCS13A
DISC	STAINLESS STEEL	A351 Gr. CF8/SCS13A

Specifications

10K CAST STAINLESS STEEL SWING CHECK VALVE FLANGED ENDS

End to End : ASME B16.10 CLASS 150, End Connection : JIS B2220 10K, Wall Thickness : ASME B16.34 CLASS 150, Test Standard : KITZ STANDARD, Sizes : 11/2-14inch(40-350mm), Approvals : Japan Valve Manufacturer's Association 40-350 mm (11/2-14 inch), BODY MATERIAL : STAINLESS STEEL, COVER MATERIAL : STAINLESS STEEL, DISC MATERIAL : STAINLESS STEEL, KITZ Fig : 10UOAT



JV

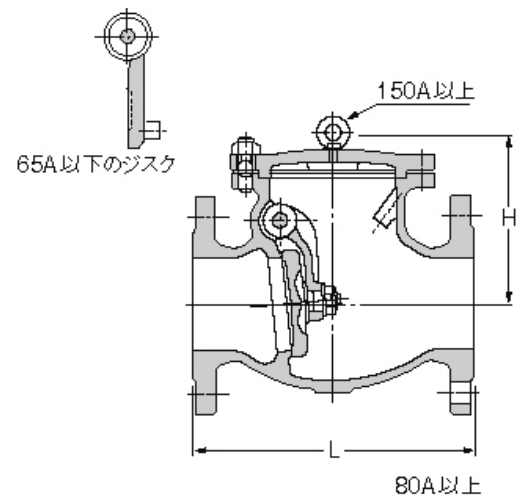

For more details, please refer to the drawing.

Pressure-temperature ratings and other performance data published in this catalog have been developed from our design calculation, in-house testing, field reports provided by our customers and/or published official standards or specifications. They are good only to cover typical applications as a general guideline to users of KITZ products introduced in this catalog. For any specific application, users are kindly requested to contact KITZ Corporation for technical advice, or to carry out their own study and evaluation for proving suitability of these products to such an application. Failure to follow this request could result in property damage and/or personal injury, for which we shall not be liable. Read instruction manual carefully before use.

KITZ

KITZ CORPORATION Tokyo Shiodome Building, 1-9-1, Higashi-Shimbashi, Minato-ku, Tokyo 105-7305, Japan
© KITZ Corporation. All Right Reserved.

ISO 9001
CERTIFIED
Since 1989

●Aシリーズ・HAシリーズ・AJシリーズ (JIS B 2220-2004) 単位:MPa

呼び圧力	10K				20K			
	SCS13A	SCS14A	SCS16A	SCS19A	SCS13A	SCS14A	SCS16A	SCS19A
使用温度(°C)								
~120	1.4	1.4	1.4	1.4	3.4	3.4	3.4	3.4
220	1.2	1.2	1.2	1.2	3.1	3.1	3.1	3.1
300	1.0	1.0	1.0	1.0	2.9	2.9	2.9	2.9
350	—	—	—	—	2.6	2.6	2.6	2.6
400	—	—	—	—	2.3	2.3	2.3	2.3
420	—	—	—	—	2.0	2.0	2.0	2.0

注意

- ガスケットおよびパッキン材料によって最高使用温度は変わります。上表に示しています材料ごとの最高使用温度をご確認ください。
- AJシリーズはジャケットの最高使用温度/圧力は260℃/1.0MPaです。これ以上での使用の場合はお問合せください。

Pressure-temperature ratings and other performance data published in this catalog have been developed from our design calculation, in-house testing, field reports provided by our customers and/or published official standards or specifications. They are good only to cover typical applications as a general guideline to users of KITZ products introduced in this catalog. For any specific application, users are kindly requested to contact KITZ Corporation for technical advice, or to carry out their own study and evaluation for proving suitability of these products to such an application. Failure to follow this request could result in property damage and/or personal injury, for which we shall not be liable. Read instruction manual carefully before use.

KITZ

KITZ CORPORATION Tokyo Shiodome Building, 1-9-1, Higashi-Shimbashi, Minato-ku, Tokyo 105-7305, Japan
© KITZ Corporation. All Right Reserved.

ISO 9001
CERTIFIED
Since 1989