

10K DUCTILE IRON, LIFT CHECK VALVES

KITZ Fig: 10SF

Sizes: 1/2-2inch(15-50mm)

SCREWED CAP, SCREWED ENDS.

Standards

- . End to End: JIS B2051
- . End Connection: JIS B0203
- . Wall Thickness: JIS B2051

Test Standard

- . KITZ STANDARD

Conform to

MLIT 15-50 mm (1/2-2 inch)

approved

Dimensions

SIZE (inch/mm)	L	L1	H	D1	Kg
1/2 15	65.0	0.0	39.0	0.0	0.00
3/4 20	80.0	0.0	42.0	0.0	0.00
1 25	90.0	0.0	48.0	0.0	0.00
1 1/4 32	105.0	0.0	56.0	0.0	0.00
1 1/2 40	120.0	0.0	65.0	0.0	0.00
2 50	140.0	0.0	73.0	0.0	0.00

Material List

NAME OF PART	MATERIAL	SPECIFICATION
BODY	DUCTILE IRON	FCD-S
CAP	STAINLESS STEEL	SCS1
DISC	STAINLESS STEEL	SCS1

Specifications

10K DUCTILE IRON, LIFT CHECK VALVES, SCREWED CAP, SCREWED ENDS.

End to End : JIS B2051, End Connection : JIS B0203, Wall Thickness

: JIS B2051, Test Standard : KITZ STANDARD, Sizes :

1/2-2inch(15-50mm), Conform to : MLIT 15-50 mm (1/2-2

inch), BODY MATERIAL : DUCTILE IRON, CAP MATERIAL : STAINLESS

STEEL, DISC MATERIAL : STAINLESS STEEL, KITZ Fig : 10SF



国 土

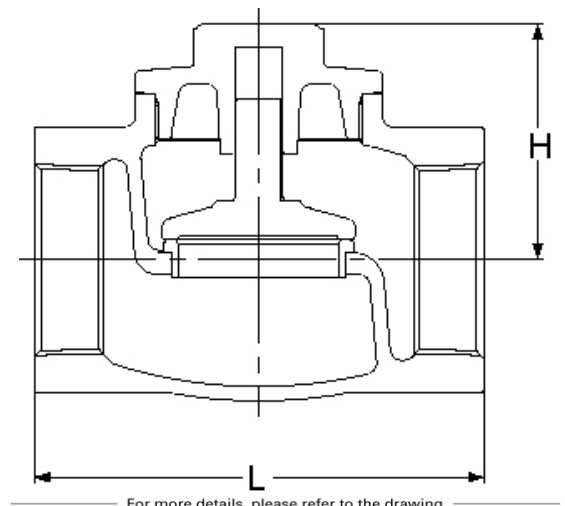

For more details, please refer to the drawing.

Pressure-temperature ratings and other performance data published in this catalog have been developed from our design calculation, in-house testing, field reports provided by our customers and/or published official standards or specifications. They are good only to cover typical applications as a general guideline to users of KITZ products introduced in this catalog. For any specific application, users are kindly requested to contact KITZ Corporation for technical advice, or to carry out their own study and evaluation for proving suitability of these products to such an application. Failure to follow this request could result in property damage and/or personal injury, for which we shall not be liable. Read instruction manual carefully before use.

KITZ

KITZ CORPORATION Tokyo Shiodome Building, 1-9-1, Higashi-Shimbashi, Minato-ku, Tokyo 105-7305, Japan
© KITZ Corporation. All Right Reserved.

ISO 9001
CERTIFIED
Since 1989