



**Climate
Control**

Our product brands:
IMI Pneumatex
IMI TA
IMI Heimeier

Hydronic Solutions to Revolutionise your Data Centre Cooling Strategy

Secured reliability and sustainable efficiency



Breakthrough
engineering for
a better world

Index

Introduction	03
1. Experience Reliability and Security	04
2. Superior Energy Efficiency and Precision Cooling	17
3. Expert Support for Simplifying Design	25
Reference Cases	27
HVAC Applications	30

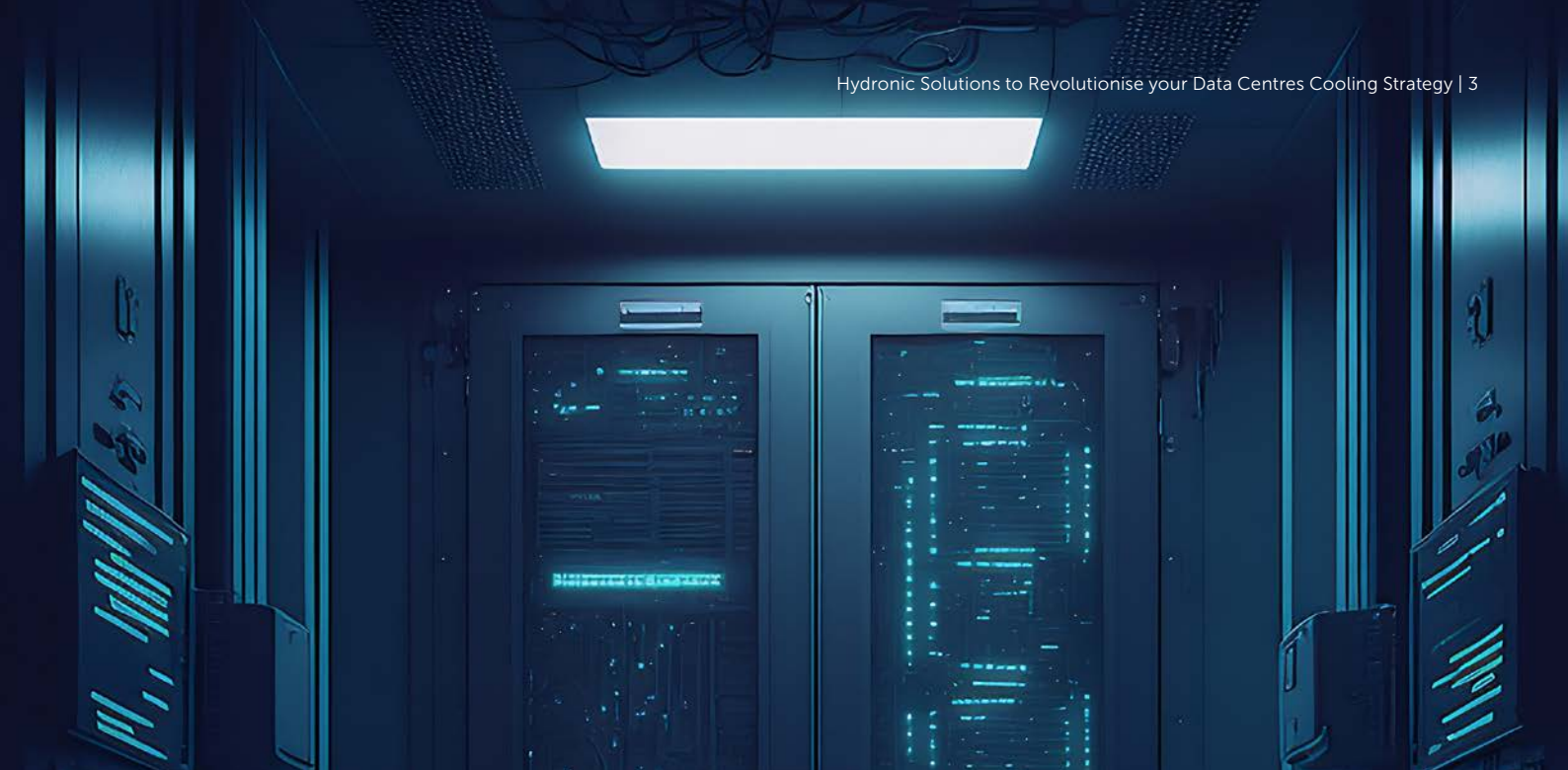

Introduction

Data reigns supreme in today's digital era, and the worldwide surge of Data Centres underscores their critical role in modern society. The distinctive needs of Data Centres arise from the intricate nature of their operations. They face the challenge of managing substantial heat generated by densely packed equipment, requiring advanced, reliable and energy efficient cooling solutions. These particular demands stretch the boundaries of standard HVAC capabilities, necessitating expert knowledge and customised solutions.

When it comes to Data Centres operations, the integrity and security of invaluable data rely on precise and unfailing temperature control. HVAC systems are responsible for this control and, therefore, their flawless performance plays an intrinsic role in upholding the security and stability of Data Centres critical application.

But that's not all; beyond operating flawlessly and continuously, Data Centres face the challenge of minimising energy consumption whilst transitioning towards carbon neutrality and adopting more sustainable energy sources.

As an HVAC expert with over 300 years of combined experience in 3 key system areas, IMI is the perfect partner to help you tackle these and other challenges HVAC systems in Data Centres.

We offer innovative products, reliable technologies, and personalised support from the design stage to installation and operation, ensuring that your HVAC system operates sustainably whilst accurately meeting its specific climate control requirements.

IMI TA

Since 1897

Balancing, Control
& Actuation leader

IMI Pneumatex

Since 1909

Pressurisation
& Water Quality
leader

IMI Heimeier

Since 1928

Thermostatic
Control leader



1. Experienced Reliability and Security

Data Centres operate 24/7, requiring uninterrupted and flawless functionality of HVAC systems – there is no margin for error. Reliable and robust HVAC solutions, including balancing and control, pressurisation, and water quality management, are essential to ensure the dependability and security of your Data Centre. To ensure protection against failures in this error-free application, it is crucial for you to choose products equipped with advanced protection features and resistant stainless solutions to deal with any advanced cooling technology like the use of water-glycole mixture.

Product Solutions

Balancing and Control Solutions

TA-Smart: Ensuring System Reliability and Security

TA-Smart, a sophisticated valve by IMI TA, is engineered to integrate seamlessly with Building Management Systems (BMS), providing essential control fallback and access control features, ideal for the maintenance of system functionality and security.

Below, we outline the key TA-Smart features for enhanced reliability and security. For more information about TA-Smart, please refer to the next section, 'Superior Energy Efficiency and Precision Cooling'.

BMS Control Fallback

Thanks to BMS control fallback feature, we can ensure that in the event of a primary control system failure, the TA-Smart valve can maintain its operations autonomously and continuously. Even if the BMS experiences an outage, the TA-Smart valve will continue to regulate flow, power, and position, preserving the system's integrity and preventing potential damages or operational downtimes.

Additionally if the controller has an issue, the valve can intercept that it is a controller issue and let the user par-

ametise a safety position. This autonomous capability is vital for Data Centres where uninterrupted system performance is paramount.

Pump-Off Detection

Another significant feature of TA-Smart is pump-off detection. This function ensures that the system detects any pump failures immediately. In such cases, the valve can respond appropriately, either by adjusting its settings to compensate for the loss of pump promptly: this is crucial in maintaining system efficiency and preventing potential damages.

Access Control Feature

The updated Access Control feature from TA-Smart obstructs unauthorised access to TA-Smart devices by anyone within its Bluetooth range.

Via the HyCloud portal, the project owner can grant access to specific users for TA-Smart related to a certain project. The access can be granted at various levels: full access, viewer or service.

Once connected, the person will have to validate their access to the TA-Smart device via the HyTune app using their email address. Every connection will require an authentication token to be verified for access to be granted.

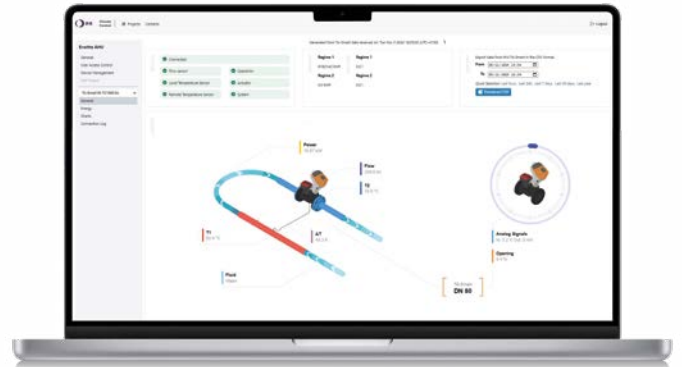

TA-Slider: Optimising Operations During Power Failures

The TA-Slider actuator is designed to ensure that the valve moves to a pre-defined position in the event of a power failure, thereby maintaining system safety and operational stability.

Below, we outline the key TA-Slider features for enhanced reliability and security. For more information about TA-Slider, please refer to the next section, 'Superior Energy Efficiency and Precision Cooling'.

Power Outage Protection

Power outages or momentary disruptions may be unavoidable at times, but their impact can be long-lasting. TA-Slider can help mitigate this risk.

In the event of an unexpected power failure, the fail-safe feature of TA-Slider ensures that the valve moves to a pre-defined position. This feature is essential for maintaining system stability and safety. By moving to a pre-defined position, the actuator can prevent potential system damage that might occur if the valve position were to remain undefined.

The user-friendly HyTune smartphone app allows you to conveniently and accurately monitor and configure crucial parameters, from the emergency position and time delay for position change to the overall health status of the actuator, and resumption of normal operations after a power failure.

In the example below, without the fail-safe feature of TA-Slider, the valve remained at its closed position not enabling a minimum flow to prevent pipe freezing. This led to repair costs and system shutdowns.



In this example, after a power supply breakage, the absence of the TA-Slider fail-safe feature led to repair costs of 242 k€ and a shutdown of the HVAC system.

HyTune App: Monitoring and Configuration

The HyTune App allows users to monitor and configure crucial parameters of the TA-Slider. This app provides real-time insights into the valve's operations, enabling users to adjust settings and resume normal operations quickly after a power failure. The HyTune App enhances the overall usability and functionality of the TA-Slider, making it a valuable tool for system maintenance and optimisation, in particular after power outages.

Reliable Pressure Maintenance Solutions

Maintaining correct pressure in water-based HVAC systems is vital to account for temperature fluctuations that cause fluid volume to expand or contract. Excessive pressure can lead to pipe ruptures, whilst insufficient pressure allows air to enter the system – the biggest threat to the long-lasting functionality of water-based systems.



Our pressure maintenance range.

Compresso Connect

IMI Pneumatex's Compresso Connect is a market-leading pressure maintenance device with integrated vacuum degassing. The precision and reliability of the Compresso Connect ensure that pressure is consistently maintained, preventing fluctuations that could impact the performance of cooling systems. It is equipped with Butyl Bag technology and BrainCube as a standard.



Precision Pressure Maintenance

The Compresso systems maintain pressure with a precision of ± 0.1 bar, ensuring that the Data Centre's cooling systems operate within optimal parameters.

ECO-Night Functionality

This feature allows the system to operate in an energy-saving mode during low-demand periods, reducing energy consumption and operational costs, meeting the sustainability goals of modern Data Centres.

Integrated Components

Each unit comes equipped with a compressor, spill valve, and a primary vessel. Some models, like Compresso

C 2.1-80 SWM, also include a water meter and solenoid valve for water make-up, enhancing the system's functionality and making it a 3-1 device.

Remote Control and Monitoring

Compresso Connect can be monitored and controlled remotely, providing real-time data and alerts that facilitate proactive maintenance and rapid response to any issues.

Ease of Integration

With their compact design and integrated components, Compresso units can be easily installed and integrated into existing Data Centres infrastructure, minimising downtime during installation and maintenance.

Transfero TV Connect

The Transfero TV Connect represents a significant advancement in pressure maintenance and degassing technology. It is designed to provide precise pressure control, efficient degassing, and integrated water make-up, making it a 3-in-1 device and a comprehensive solution for Data Centres.



Integrated Vacuum Degassing

Unlike competitors that only offer natural degassing at ambient pressure, the Transfero TV Connect systems incorporate vacuum degassing. This ensures the removal of dissolved gases from the water, preventing corrosion and improving the efficiency of the cooling system.

Precision Pressure Maintenance

The Transfero TV Connect systems maintain pressure with a precision of ± 0.2 bar, ensuring optimal performance of the cooling systems in Data Centres.

Increased Reliability

These models with two pumps offer internal redundancy which through the Master-Slave operation can be extended to a physical TecBox redundancy (1 TecBox master and 1 or more TecBoxes as backup slaves).

3-in-1 Device Functionality

The Transfero TV Connect systems manage pressure maintenance, degassing, and water make-up in one single unit. This 3-in-1 functionality reduces the complexity of the cooling system infrastructure, making it easier to manage and maintain.

Remote Control and Monitoring

Like the Compresso systems, the Transfero TV Connect systems offer remote control and monitoring capabilities, enhancing operational oversight and maintenance efficiency.

Sustainability

Efficient water management and reduced energy consumption contribute to the sustainability goals of modern Data Centres, aligning with industry trends towards greener operations.

The Bag Makes the Difference: Butyl Bag

A pressure maintenance system serves two primary purposes: ensuring consistent positive pressure throughout the system and preventing overpressure. The reliable performance of either is directly linked to the **air cushion's ability** to maintain a tight seal and the pressure control of the long-term performance.

Indeed, our expansion vessels stand out due to their innovative design featuring a specialised Bag.

Unlike traditional membrane vessels, our vessels prevent water from touching the metal walls of the vessel, ensuring enhanced durability and performance.

Made of Butyl rubber, our Bag has one of the market's lowest air diffusion rate, **surpassing most of other comparable membrane material by 5 to 10 times**. This feature ensures that the initial pressure remains largely unaffected, contributing to optimal performance.



Our Statico Vessel with integrated Butyl Bag.

Why Our Butyl Bag Stands Out from the Rest:

High-quality: Our vulcanised Bags are constructed from top-quality Butyl rubber with exceptional diffusion resistance, ensuring long-lasting performance.

Design optimisation: The two-fold attached Butyl Bag is designed for an approximate nominal volume, preventing over-expansion and minimising wear over time.

Corrosion prevention: Water is securely contained within the Butyl Bag, eliminating any contact with the vessel wall and protecting against corrosion. This design leads to a longer service life and eliminates costs associated with premature replacements.

Minimal operational costs: Our Butyl Bag offer reliable and nearly maintenance-free operation at stable preset pressures, minimising operational expenses.

Double protection: The Butyl Bag ensures dual protection, safeguarding not only the vessel but also the entire system, eliminating consequential costs due to corrosion.

Outstanding performance: In tests involving several manufacturers, IMI Pneumatex outperformed competitors, as demonstrated by minimal primary pressure loss, the elimination of the need for initial over-pressure, and the absence of residual water inclusion.

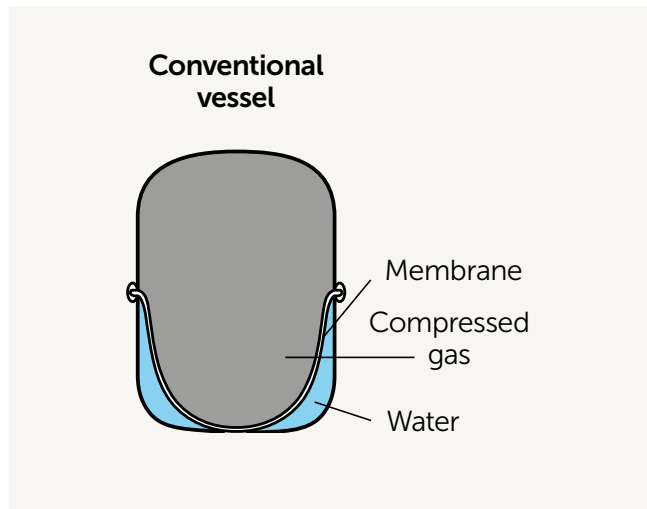
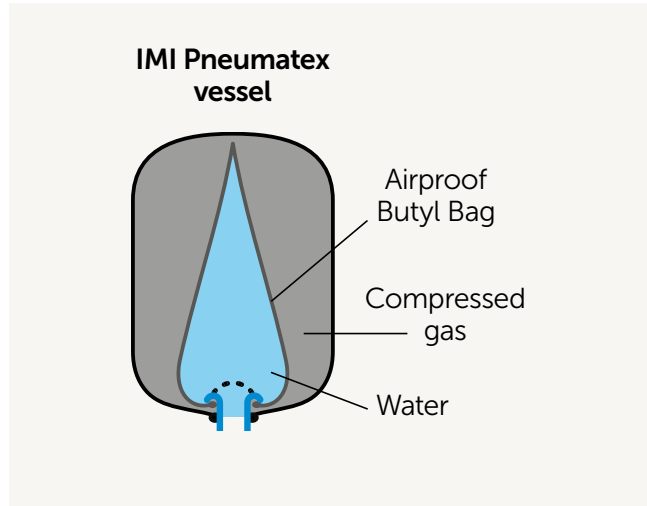

Proof of Performance

An independent study conducted by an external institute tested the pre-pressure loss of eight expansion vessels over one year of operation.

The graph illustrates how the IMI Pneumatex vessel equipped with Butyl Bag was at least 5 times more efficient at maintaining optional pressure than any other expansion vessels tested.

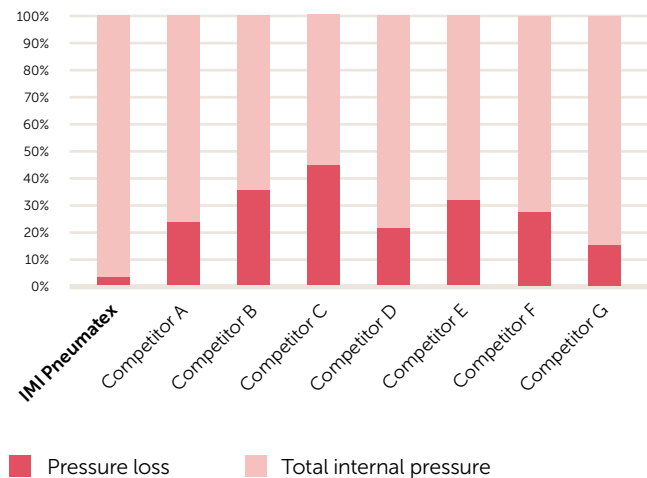

Source: The Karel de Grote-Home-school in Belgium carried out a quality comparison with expansion vessels.

Connected Pressure Maintenance: BrainCube Connect

What further distinguishes our IMI Pneumatex pressure maintenance systems is the BrainCube Connect control unit.

The BrainCube facilitates easy access to critical system information for your pressure maintenance equipment via any connected device, whether you are on or off site.

Its communications and connectivity versatility allows for seamless integration with your building management system (BMS) through the standardised Modbus protocol on RS485 (RTU). It also provides a direct on-site connection via Ethernet and the capability to link to the Web-Interface Cloud solution, giving you full visibility and control anytime, anywhere.

If a system fault is detected, an alert is sent directly to the user, allowing remote access to system settings, adjustments, or specialised service.

This provides total visibility and control, crucial for critical applications such as Data Centres, where there is no margin for error.

For maximum security projects where data cannot leave the premises, the cloud connection can be disabled. System information can be accessed directly through the BrainCube touchscreen, including water make-up counts, fill safe status, vacuum split details, pump running duration, and system low and high-pressure readings.



BrainCube Tier-Protection Functionality: Master-Slave

Critical applications, such as Data Centres, often require multiple sub-power plants located kilometres away from the main thermal power plant for reasons like redundancy or expanding power demand. Connecting these widely spaced substations through traditional

wiring is challenging. Master-Slave communication via Ethernet-Multicast for IMI Pneumatex revolutionises this by using existing Ethernet networks, eliminating the need for complex cabling between substations and ensuring effective communication.

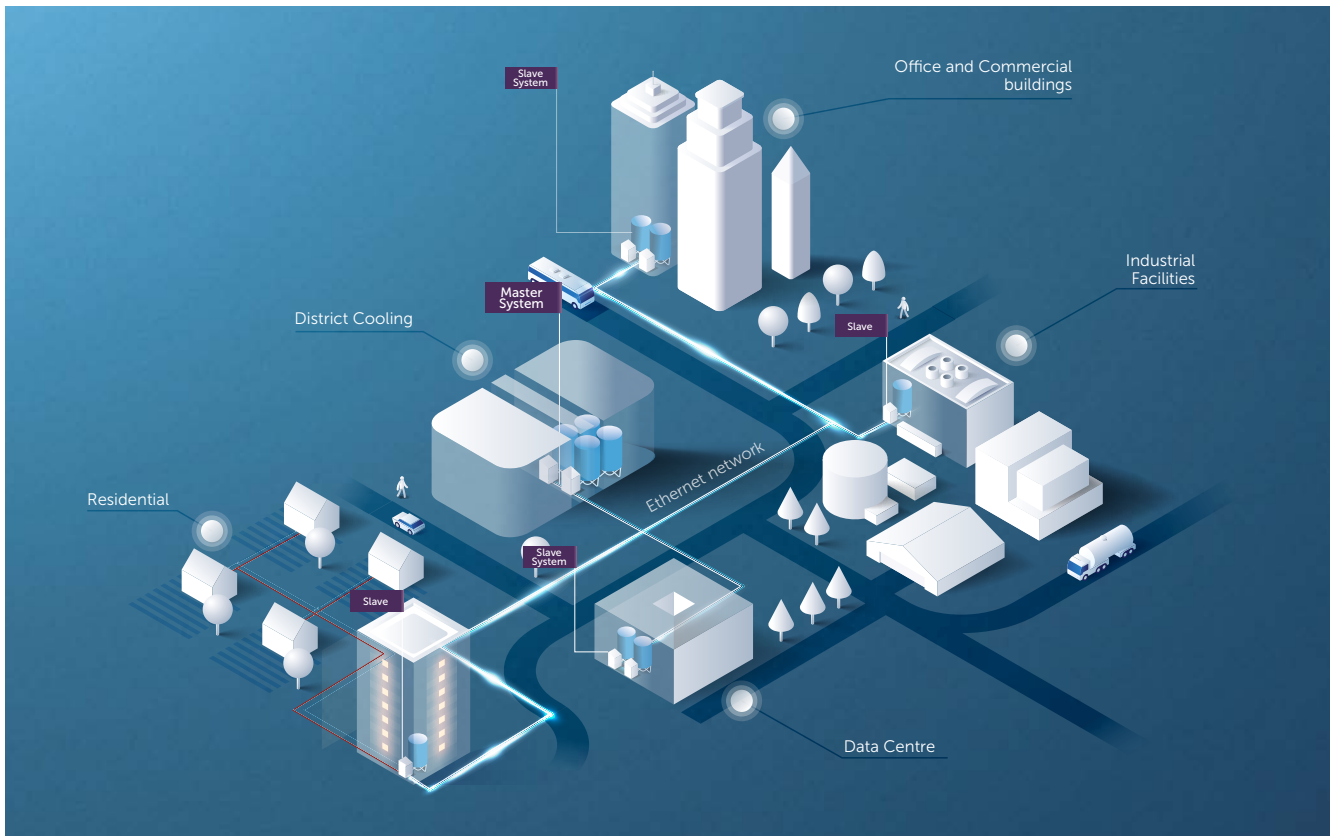

Enhancing Safety

As a trusted provider of HVAC systems, we understand the critical importance of Data Centres security and the confidential aspects that come with it. We are committed to excellence and adhere to the highest industry standards through the implementation of robust security measures.

Our advanced HVAC solutions safeguard vital data and assets, ensuring their utmost security. Our connected products, such as TA-Smart and the BrainCube control panel, deliver heightened safety for mission-critical applications. Featuring comprehensive protocols for physical security, regular maintenance, network security, and backups, our smart connected features guarantee the highest level of protection for your data. Additionally, in projects where data must

remain within the facility, **our cloud connection can be deactivated**, ensuring secure system monitoring within the controlled environment. Throughout every phase of a project, we uphold the highest standards to safeguard customer confidentiality and client information. Leveraging our extensive experience across numerous projects, we excel in adapting to various levels of security, ensuring flexibility to meet your specific needs.

Water Quality Management Solutions

Air, primarily composed of nitrogen and oxygen, poses the biggest threat to water-based heating and cooling systems. It infiltrates HVAC systems through mains water during initial fill-up and subsequent refilling via the water make-up device. Additionally, negative pressure conditions caused by factors like poor pressurisation, inadequate water reserve, or incorrect initial pressure may also result in air infiltration.

The presence of **air** has severe consequences, including disruptive flow noise and reduced cooling transfer. The problems don't end there, because air once inside reacts with metal components in the system leading to erosion and corrosion of expensive equipment. These rust and **dirt** deposits will travel and accumu-

late in the system causing obstructions, premature failures and reduced overall system efficiency. None of these consequences are worth the risk for a building that must operate continuously and flawlessly. Ensuring the prompt and effective removal of air and dirt should be a top priority.



Typical consequences from poor water quality management.

Removing Air

Achieving optimal air removal from your HVAC system requires precision by utilising the appropriate product combination.

Air pockets and free gases can be efficiently removed by installing automatic vents at the highest points of the system, specifically at the top of the main risers. This enables the safe and automatic evacuation of accumulated air.



Zeparo Aero, microbubble separator by IMI Pneumatex.

When it comes to microbubbles removal, it could be necessary to use microbubbles separators such as Zeparo Aero.

The helicoidal technology combines the principles available in the market whilst avoiding their disadvantages:

- Flow rate is reduced such that large bubbles can rise very quickly.
- A large number of inclined wings redirect the bubbles upwards.

- The helicoidal separator (which has a large surface area) captures the microbubbles in an optimal way with its many wells and tips.
- The helicoidal arrangement (an upwards spiral) allows even the smallest bubbles to rise in the central column with little turbulence.
- Thanks to the improved flow technology, the bubbles form outside the main flow.
- The wings ensure a large calm area in the upper section of the separator, where bubbles can easily appear.

In systems with lower water temperatures the air becomes more tightly bonded to the water molecules. This makes it impossible to separate air from water effectively by using separators or automatic air vents. In such cases, **vacuum degassers are the only reliable method to remove air.**

As gases enter the system from the mains, rich in gas due to water make-up, it is imperative to degas the make-up water before it enters the system and potentially causes damage.

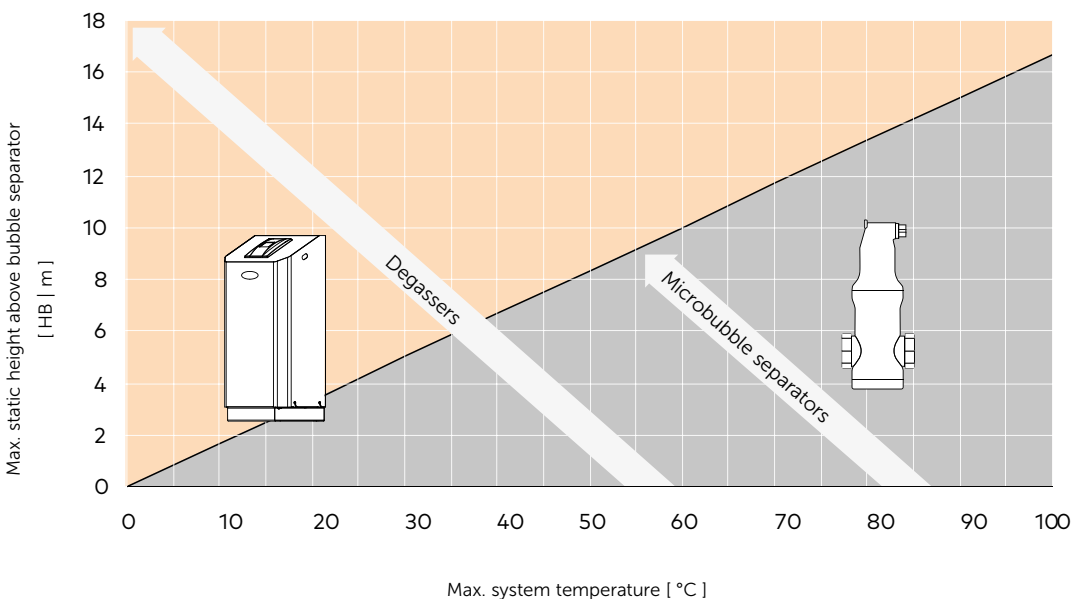

Microbubble separators are fully functional only below the shown line. Degassers that are capable of removing dissolved gases in addition to possible free gas bubbles are the solution when microbubble separators reach their physical limit.

IMI Pneumatex’s vacuum degassers offer unparalleled efficiency in the market. These degassers utilise Cyclonic Vacuum Degassing technology, which employs pressure and flow restriction to create a concentrated spiral vortex that effectively concentrates and then removes air.

As flow speed decreases, air bubbles naturally rise to the top and can be easily eliminated. It is recommended to install vacuum degassers near the expansion vessel, at the system return, and safeguard them with a dirt separator equipped with a powerful magnetic rod. Vento’s have the function of managing make-up water, which is degassed before it is sent into the system.



Vento Connect, cyclonic vacuum degasser by IMI Pneumatex.

Proof of Performance

Vento Connect solutions reduce air content more effectively than competitors, as proven by third-party testing from TU Dresden Institute.

Vacuum degassing - 1.8 m³ cooling circuit - water

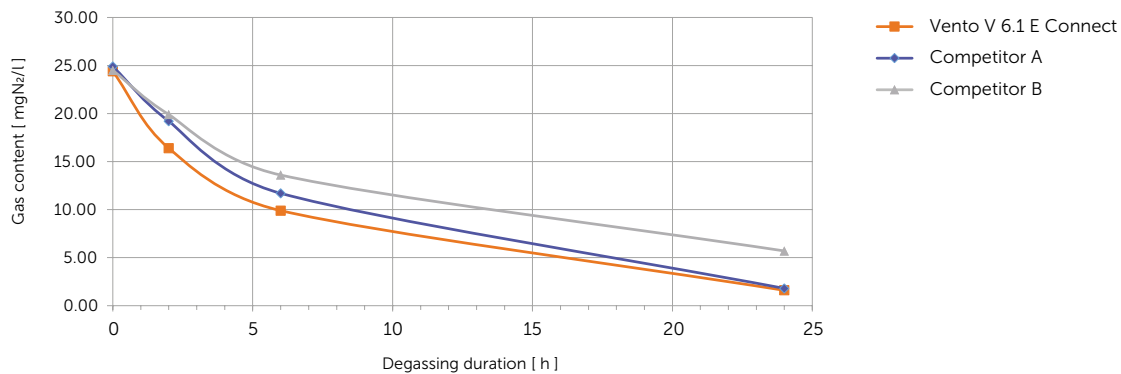

Vacuum degassing - 450 l cooling circuit water with 25% ethylene glycol

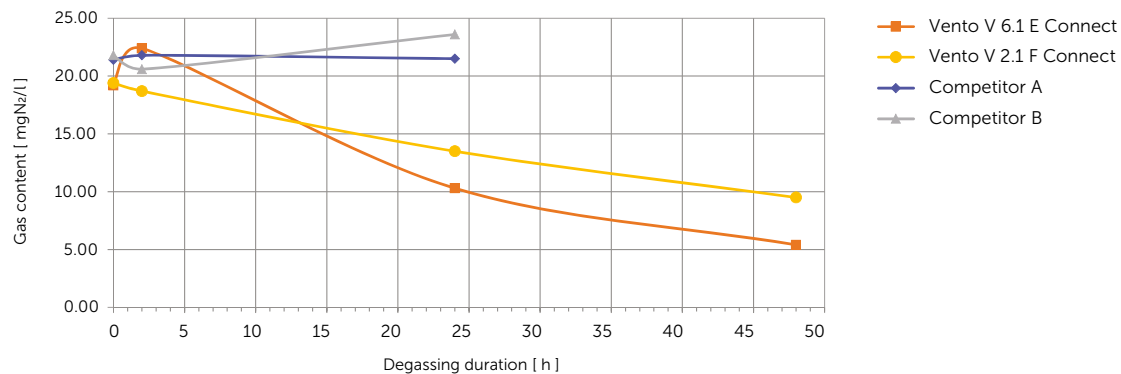

Tests for competitors A and B were stopped after 24 hours because no degassing effect was visible. Increased measurement values can be explained by the subsequent dissolution of N₂ gas bubbles in the circuit.

Removing Dirt

Rust resulting from corrosion in boilers, pipes and terminal units reduces the specific heat transfer and increases the pressure drops and fluid velocity in the hydronic system.

To address dirt in HVAC systems effectively, it is crucial to consider their composition and size, as well as the water velocity conditions. Whilst typical strainers and filters capture large dirt and sludge particles, they can become clogged over time, leading to increased pressure drop (Δp) and reduced effectiveness. Dirt separators maintain particles separation consistently, preventing excessive dirt build-up and minimising interference with Δp .



Zeparo Cyclone Max, dirt separator by IMI Pneumatex.

IMI Pneumatex's Zeparo Cyclone Max which is equipped with Cyclonic Dirt Separation technology stands out in the market as the leading solution for dirt separation. It is the sole technology capable of effectively removing dirt at all water speeds and pipe sizes.

To prevent dirt circulation and adherence to equipment, Cyclonic technology effectively eliminates up to 95% of dirt in a single cycle*, capturing even small particles (5-10 μm) thanks to the strongest magnet in the dirt separators market.

It is easy to install in both horizontal and vertical orientations, fitting into tight spaces and retrofitting effortlessly with other separators. Additionally, its excellent energy efficiency can help you save 3% to 7% on primary energy consumption after three years installation. **

* Depending on particle sizes

** Visit our website for more details: <https://uqr.to/energy-facts>

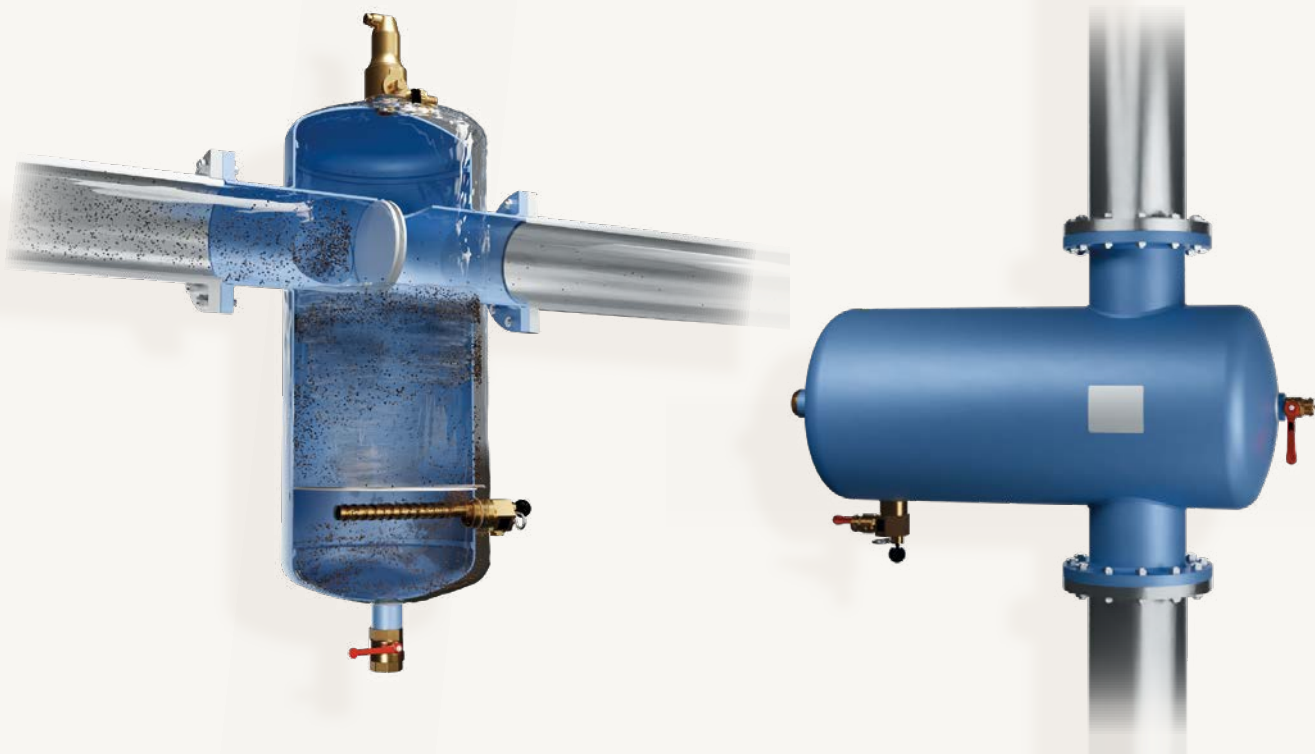

How Cyclone Dirt Separation Technology Works:

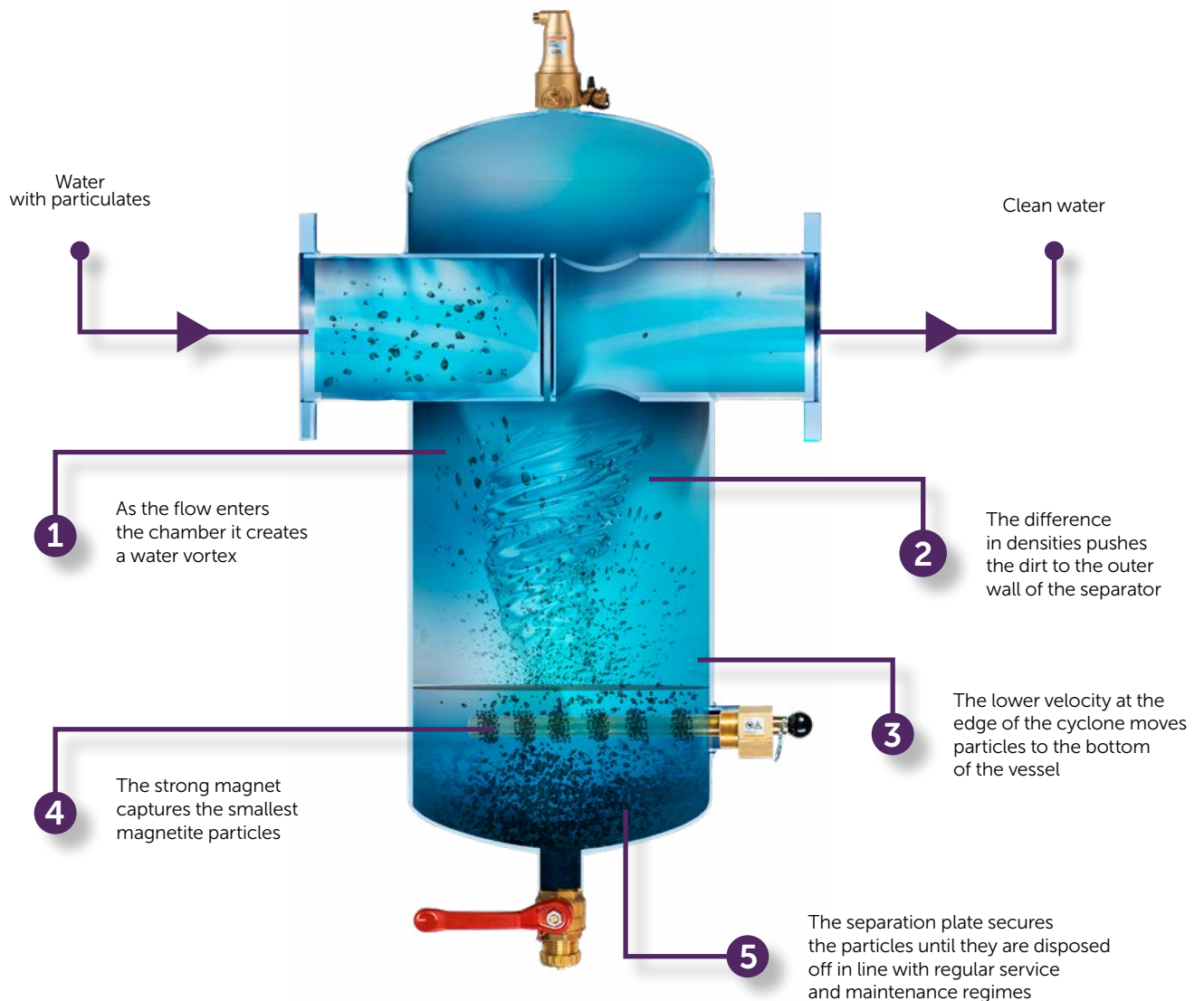

1. Upon entering the chamber of the separator, the water flow undergoes a centrifugal force, generating a water vortex that exerts considerable pressure on dirt particles, forcefully propelling them toward the separator's outer wall.

2-3. This Cyclone effect remains consistent regardless of the positioning – horizontal or vertical. Moreover, it maintains high separation efficiency even in high flow

conditions and with large DN's – setting it apart from gravitational separation technologies offered by other manufacturers.

4-5. The lower velocity around the periphery of the cyclone allows gravity to assist in moving the particles to the bottom of the separator. A retarding plate at the bottom ensures the dirt particles remain captured in the chamber until they are disposed off.

This makes the Cyclone Range from IMI Pneumatex the most versatile and reliable dirt separator in the market, regardless of positioning, dimension, or flow conditions, as proven by independent third-party test lab by HLK Stuttgart GmbH.

Proof of Performance

An independent study by HLK Stuttgart GmbH was conducted to test the separation efficiency of the Zeparo Cyclone Max. It was tested against three competitors to assess the separation efficiency of particles from 5 to 300 µm in diameter in just one cycle. The findings unequivocally show the superiority of Cyclonic Dirt technology across different dimensions and flow conditions. Particularly noteworthy was the remarkable performance of Zeparo Cyclone Max DN200 versus other equipments, where competitors simply were unable to deliver relevant separation performance.

Separation Efficiency of Particles from 50 to 300 µm in Diameter in Just One Cycle

Separation Efficiency DN65

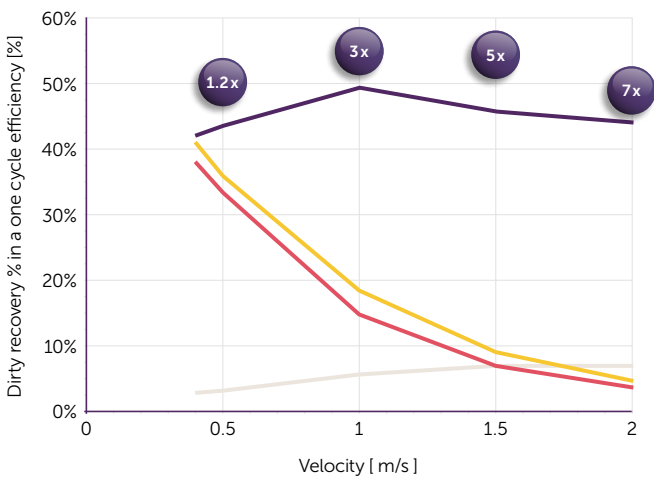

Separation Efficiency DN200

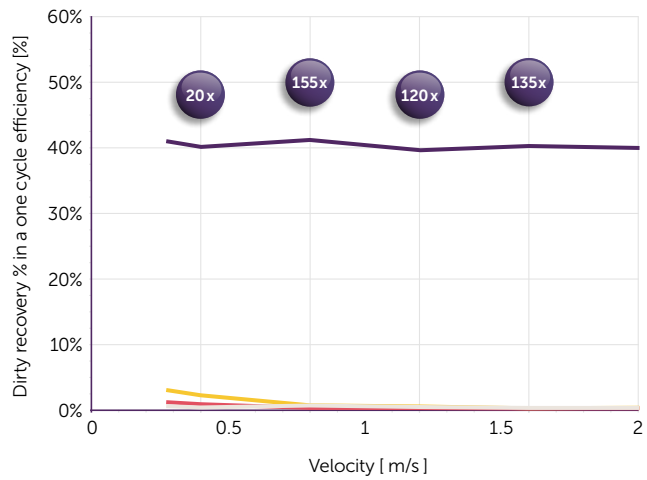

Zeparo Cyclone Dirt

Competitor A

Competitor B

Competitor C

X More efficient than the next competitor

Removing Magnetite

Magnetite particles, being light and very small (<0.5µm), necessitate specialised magnets for effective separation. For systems facing specific and severe magnetite challenges, the installation of dedicated magnetic separators is imperative.

Ferro-Cleaner outperforms competitors due to its advanced magnet design, ensuring correct polarisation (North to North, South to South), optimal spacing, and larger diameters for increased mass. This design enhances the magnetic range in water and improves surface adhesion for effective particle attraction and removal.

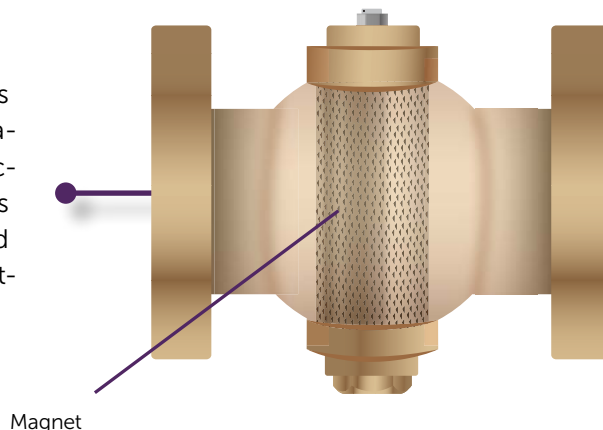

Magnet

The magnet rod in the Ferro-Cleaner occupies its entire height.

2. Superior Energy Efficiency and Precision Cooling Solutions

Data Centres form sensitive ecosystems where maintaining precise temperature control is not just essential but paramount. The substantial heat produced by servers and networking equipment requires the implementation of precise cooling mechanisms to sustain optimal operating conditions.

Minor fluctuations in temperature can have a notable impact on system performance and, ultimately, compromise the integrity of stored data. At the same time, high-load conditions required for effective and constant cooling leads to substantial power consumption, impacting both operational costs and environmental sustainability targets. Various countries have implemented regulations and standards specifically tailored to Data Centres, including the EU Code of Conduct for Data Centres. These guidelines advocate for the utilisation of eco-friendly materials in construction and

mandate the implementation of methods for measuring water and energy usage. The goal is to assess the impact of the cooling infrastructure in relation to overall consumption. Data Centres operators must report this figure to the European Commission, which then imposes restrictions on energy usage per square meter or per unit of computing power and sets targets for reducing carbon emissions. As Data Centres proliferate, adherence to these regulations becomes integral in influencing the design and operation of their HVAC systems to ensure compliance.

Product Solutions

Smart Valves

TA-Smart is an innovative balancing and control valve designed for heating and cooling applications built upon three core pillars: Control, Measurement and Communication.

TA-Smart (DN15 to DN125)



CONTROL

Versatility of valve control modes operating according to flow, power valve position and Delta P with outstanding controllability. A Delta T limitation function can be added to any of the control type, even in part-load system conditions.



MEASUREMENT

Continuous measurement of flow, valve position, return/supply temperatures, temperature difference, power and energy.



COMMUNICATION

Communicates and stores: BLE, bus, Analog, Cloud. Fully digitally configurable: HyTune mobile App, Web App.

Dynamic Control Modes

TA-Smart features four distinct control modes, functioning based on flow, power, valve position, and Delta P, complemented by internal control feedback for comprehensive and autonomous smart control.

The addition of a Delta T limitation function, applicable across all control types, effectively addresses the challenges posed by the Low Delta T syndrome, even in part-load system conditions.



* A ΔT limitation function can be added to any of the three control control modes.

** Available with TA-Smart-DP and DP sensor.

When in **flow control mode**, the TA-Smart valve measures the flow rate and feeds the actuator with the new target position to achieve the required flow. Target flow is adjusted by the controller in line with the programmable characteristic within the TA-Smart. Seamless communication with its actuator enables dynamic adjustments, ensuring the valve meets specific room requirements with efficiency.

When in **power control mode**, the TA-Smart carefully measures how much water is flowing through the valve and checks the temperature difference between the supply and return. This data enables the valve to precisely determine the power it delivers. When adjustments are necessary, it communicates with its actuator, fine-tuning control parameters to meet the specific room requirements.

When in **position control mode**, the TA-Smart valve accurately adjusts its position to regulate the flow of water following input from the controller in the feedback loop.

The **DP (Differential Pressure) control mode** is activated using a specialised TA-Smart-DP version equipped with an external pressure sensor.

This setup offers the advantages of a built-in differential pressure controller within the valve itself.

Consequently, it eliminates the need for additional devices such as the STAP or TA-Pilot-R to maintain stable circuit pressure, crucial for effective control. Additionally, TA-Smart’s measuring capabilities allow for the access of operational data essential for system monitoring.

Two different pressure modules depending on the circuit differential pressure:

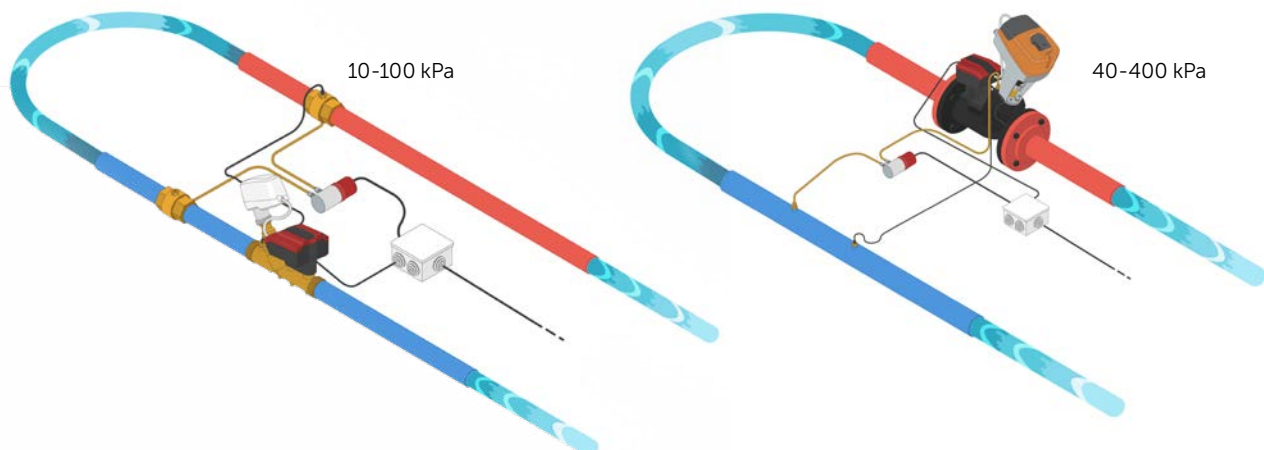

Control Precision

TA-Smart has the remarkable ability to manage flow rates as low as 0.5% of the nominal flow, even when facing differential pressures of up to 400kPa. It retains exceptional control precision across low flows, which is a critical feature, considering that in many European countries systems typically operate at about 20% flow (equivalent to 50% power) for close to 80% of their operational time.

Extreme weather conditions are not rare during the heating and cooling seasons. Yet, heating and cooling systems are primarily designed to perform under these exceptional circumstances. TA-Smart’s outstanding control precision ensures accurate temperature regulation all year-round, not just during peak conditions.

Load profile of heating system in London

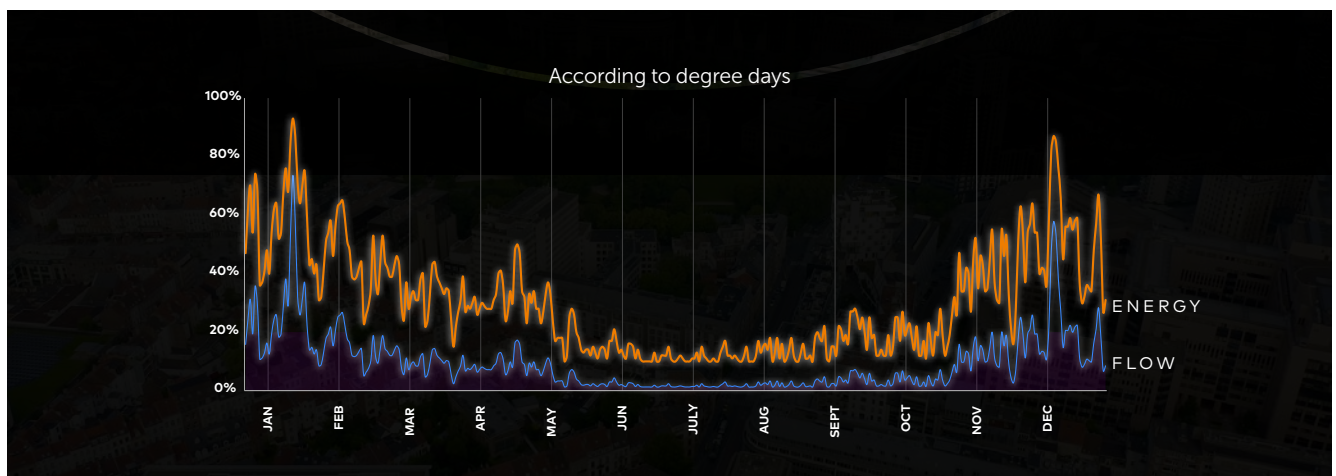

TA-Smart delivers precise control to maintain accurate temperature regulation year-round, not only during high-demand periods

Measurement Accuracy

TA-Smart provides accurate and continuous measurement of key circuit data; flow, valve position, return/supply temperatures, temperature difference, power,

and energy. Moreover, it ensures the seamless recording of this data even in the absence of BMS/internet communication.

Methodology and accuracy of measurement

$$P = k * q * \Delta T$$

<p>Flow measurement</p>	<p>TA-Smart uses Ultrasonic Flow measurement technology to guarantee high accuracy of flow measurement for all regimes at any temperature covering water-glycol mixtures of up to 57%.</p>
<p>Temperature measurement</p>	<p>TA-Smart uses two Pt1000 EN 60751 class AA temperature sensors which are pair-calibrated to provide improved accuracy even at low ΔT.</p>
<p>Power measurement</p>	<p>Leveraging accurate flow and temperature measurement, TA-Smart provides accurate power measurement in both heating and cooling applications.</p>

Reading Accuracy

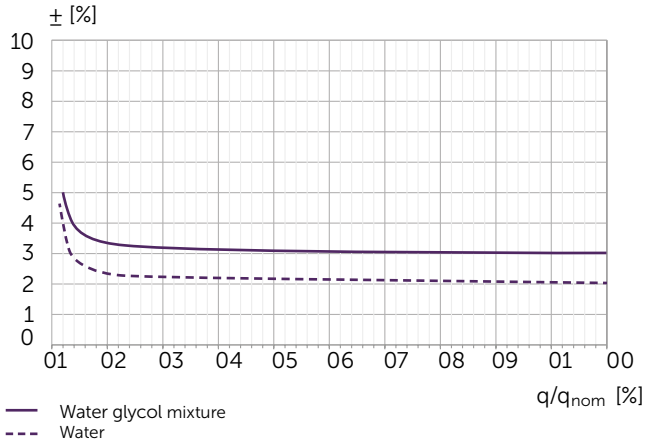

Accuracy measurement operates under the following flow conditions:

Water: From 2% accuracy at 100% of q_{nom} to 2.4% accuracy at 5% of q_{nom} (according MID-Class 2 EN1434).
Water+glycol: From 3% accuracy at 100% of q_{nom} to 4% accuracy at 5% of q_{nom} (according to MID-Class 3 EN1434).

These accuracies are subject to the requirements of upstream straight pipe lengths (OD for TA-Smart DN 15-50 and 5D for TA-Smart DN 65-125).

This data measurement not only empowers the aforementioned intelligent autonomous control but also provides clear insights into this part of the system's operations. It facilitates the validation of system performance relative to the design parameters, enabling necessary optimisation adjustments.

Similarly, troubleshooting leverages these measurements to understand system behavior, gather insights, and support confident decision-making. The integrated measurement capability means TA-Smart meets energy monitoring requirements from certification labels and regulations **without the need to install additional components.**

Communication Versatility

TA-Smart consistently logs the key circuit data through diverse communication protocols such as BLE, BUS, Analog, and MQTT. This information is easily accessible on your smartphone using the HyTune app within Bluetooth range. Alternatively, when connected to the internet, it can be remotely accessed via the BMS or HyCloud web app. This ensures quick and transparent access to essential system parameters directly from the valve whenever needed.

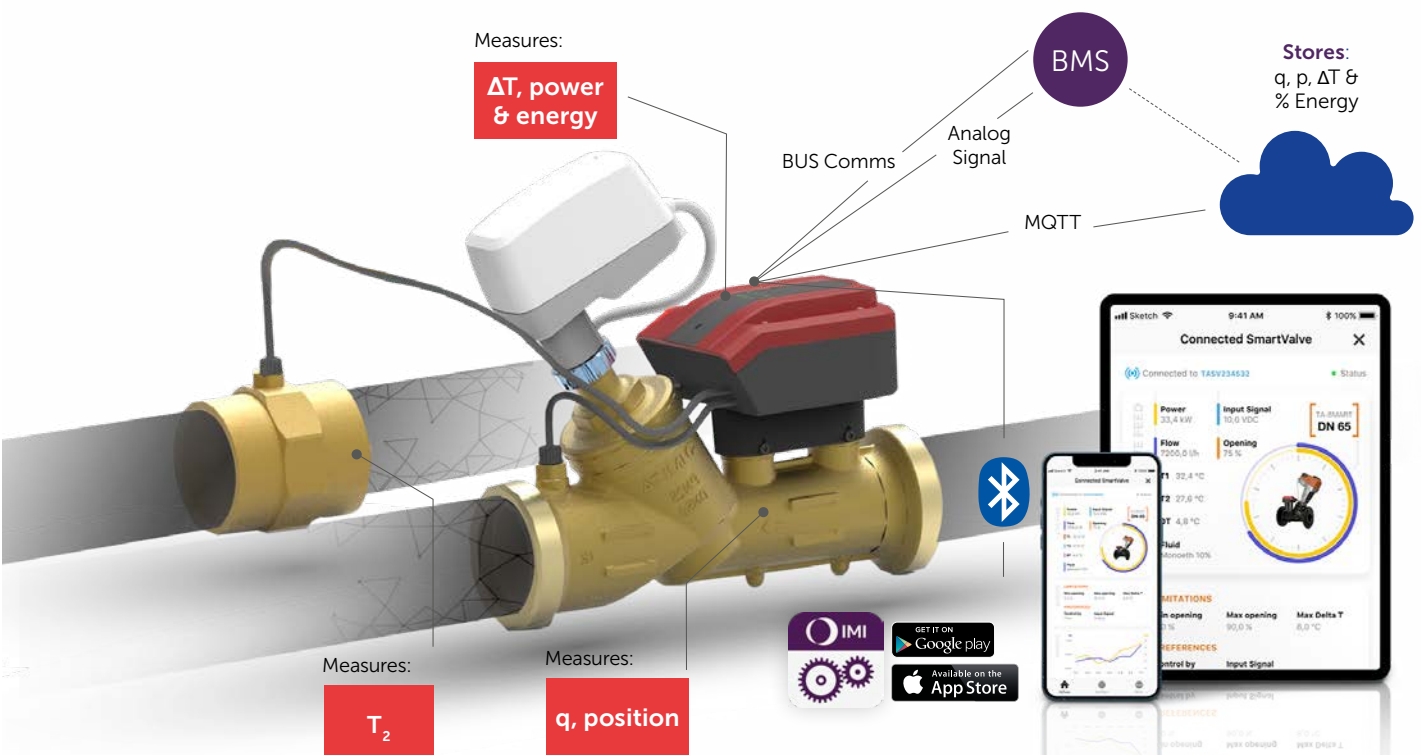

HyTune app is available on AppStore or GooglePlay

Data Security



In high-security projects where data cannot be transmitted outside the facility, **the cloud connection can be deactivated**, allowing system monitoring to be conducted securely through the app within the controlled environment.

Reduced Size & Weight

DN 15-50

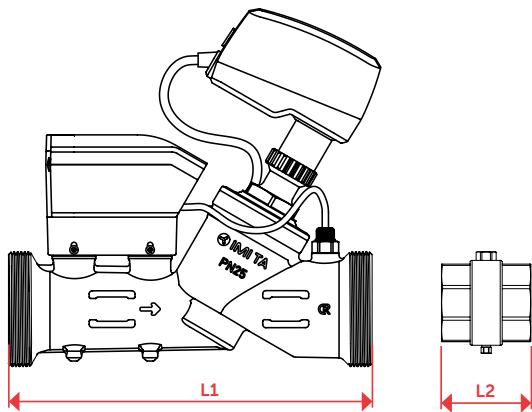

- Super compact size, the smallest of its kind
- Two bodies (only 4 fittings to mount)
- OD requirement upstream

DN	D	L1 [mm]	H [mm]	W [mm]
15	G3/4	167*	173	97
20	G1	180*	174	97
25	G1 1/4	187*	174	97
32	G1 1/2	200*	199	97
40	G2	218*	198	97
50	G2 1/2	239*	198	97

* Very compact (up to 80% smaller than competitors' product)

DN 65-125

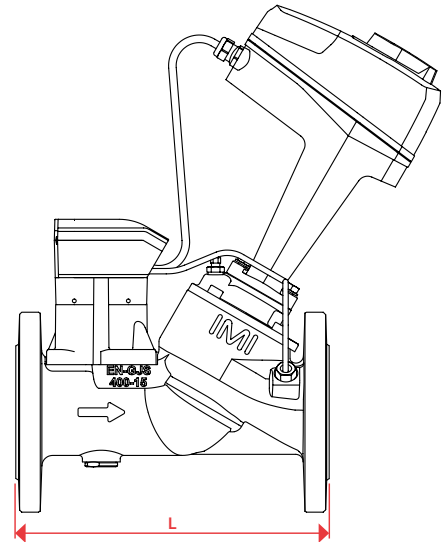

- Ultra compact F1 length (Face-to-face length EN-558-1)
- Remote temperature sensor to be fitted separately

DN	D [mm]		No of bolts		L [mm]	H [mm]
	PN16	PN25	PN16	PN25		
65	185		4	8	290*	377
80	200		8		310*	380
100	220	235	8		350*	435
125	250	270	8		400*	440

* Compact F1 length (up to 30% smaller than competitor's product)

TA-Modulator: Highly Efficient and Precise Modulating Control

Our iconic TA-Modulator is a pressure-independent balancing and control valve known for precision, reliability, and energy efficiency. Being pressure-independent means the TA-Modulator is able to keep the flow through the valve constant regardless of the pressure oscillations in the system and guarantees high control authority. It controls the flow by modulating the peaks and troughs from typical off-on control that result in temperature oscillations and higher pumping costs, helping to obtain significant energy savings.

TA-Modulator fits perfectly with our TA-Slider digital actuator. The valve's patented EQM characteristic in combination with the linear actuator offsets the non-linear characteristic of the terminal units enabling very stable and precise control, even in low flow conditions.

TA-Slider is a digital actuator, it can be seamlessly connected to BMS systems or programmed via the HyTune smartphone app. This seamless connection enables 10x more setting parameters, more accuracy in programming and up to 50% reduction in commissioning time from conventional actuators.



TA-Modulator PIBCValve with TA-Slider actuator in various dimensions (DN10 – DN200)

Our Iconic Balancing Valves



STAD Balancing Valve (DN10 to DN50)

The STAD balancing valve delivers exceptional accuracy and durability. Its user-friendly handwheel with a digital read-out ensures straightforward setting. Thanks to the precise correlation between the setting and the valve kv, you can expect accurate flow control, ensuring reliable balancing under varying flow conditions. Featuring self-sealing measuring points, it facilitates the use of the TA-Scope measuring instrument to validate the balancing process – without the risk of hot water splashes. Crafted from dezincification resistant AMETAL® alloy, it offers robustness and durability.



STAF Balancing Valve (DN20 to DN400)

The STAF flanged balancing valve offers precise and reliable balancing on the secondary side of heating and cooling systems. The digital read-out handwheel, self-sealing measuring points and a positive shut-off function simplifies precise balancing. Its cast iron (STAF) and ductile iron (STAF-SG) construction ensure reliability and versatility.



TA-BVS Balancing Valve (DN15 to DN250)

The TA-BVS balancing valve incorporates various handwheel mechanisms to ensure reliable and safe operation: the DN15-50 have a control handwheel that locks a set value. The DN65-150 have a removable handle and the DN200-250 are equipped with a manual gear. Its flange or welding end options cater to diverse requirements and the stainless-steel construction offers high-media resistance particularly suitable in industrial settings with high temperatures.

High-Performance Differential Pressure Controllers



STAP Differential Pressure Controller (DN65 to DN100)

STAP is a compact and accurate differential pressure controller, perfect for the secondary side of heating and cooling systems. It keeps the differential pressure over the load constant ensuring accurate and stable modulating control, less risk of noise from control valves and easy balancing and commissioning. Self-sealing measuring points and a positive shut-off function simplifies validation, maintenance, and troubleshooting.



TA-PILOT-R Differential Pressure Controller (DN65 to DN200)

The TA-PILOT-R is a high performing differential pressure controller, to be used in the return pipes in heating and cooling systems. It keeps a stable differential pressure over the load with unrivalled accuracy thanks to the PILOT technology providing superior control for modulating control valves. Its compact design and low weight are highly beneficial in high dimension installations – such as accurate Data Centres applications. Its measuring points enable pressure measurements for thorough system diagnostics.

Liquid Cooling

As Data Centres continue to proliferate and grow in power and complexity, the need for effective cooling methods is a constant challenge.

Liquid cooling is emerging as a modern and innovative solution as it excels in managing higher power densities. Unlike traditional air-cooled systems, which rely on hot air convection, liquid-cooled systems leverage liquids with superior cooling conduction capabilities.

These configurations include water cooling with pumps, external radiators, and water as a coolant, as well as liquid immersion cooling, which efficiently reduces temperatures by submerging equipment in a thermally conductive liquid.

Opting for liquid cooling in Data Centres requires the expertise of professional cooling engineers who consider factors such as location, environmental conditions, usage models, and airflow protocols.

Our expertise in HVAC systems allows us to understand and meet the complexities of liquid cooling effectively and work together with clients to identify the most suitable products (pressure relief valves, shutoff valves, 3-way valves, etc.) that deliver on their specific cooling needs whilst ensuring the safety and reliability of this innovative application.

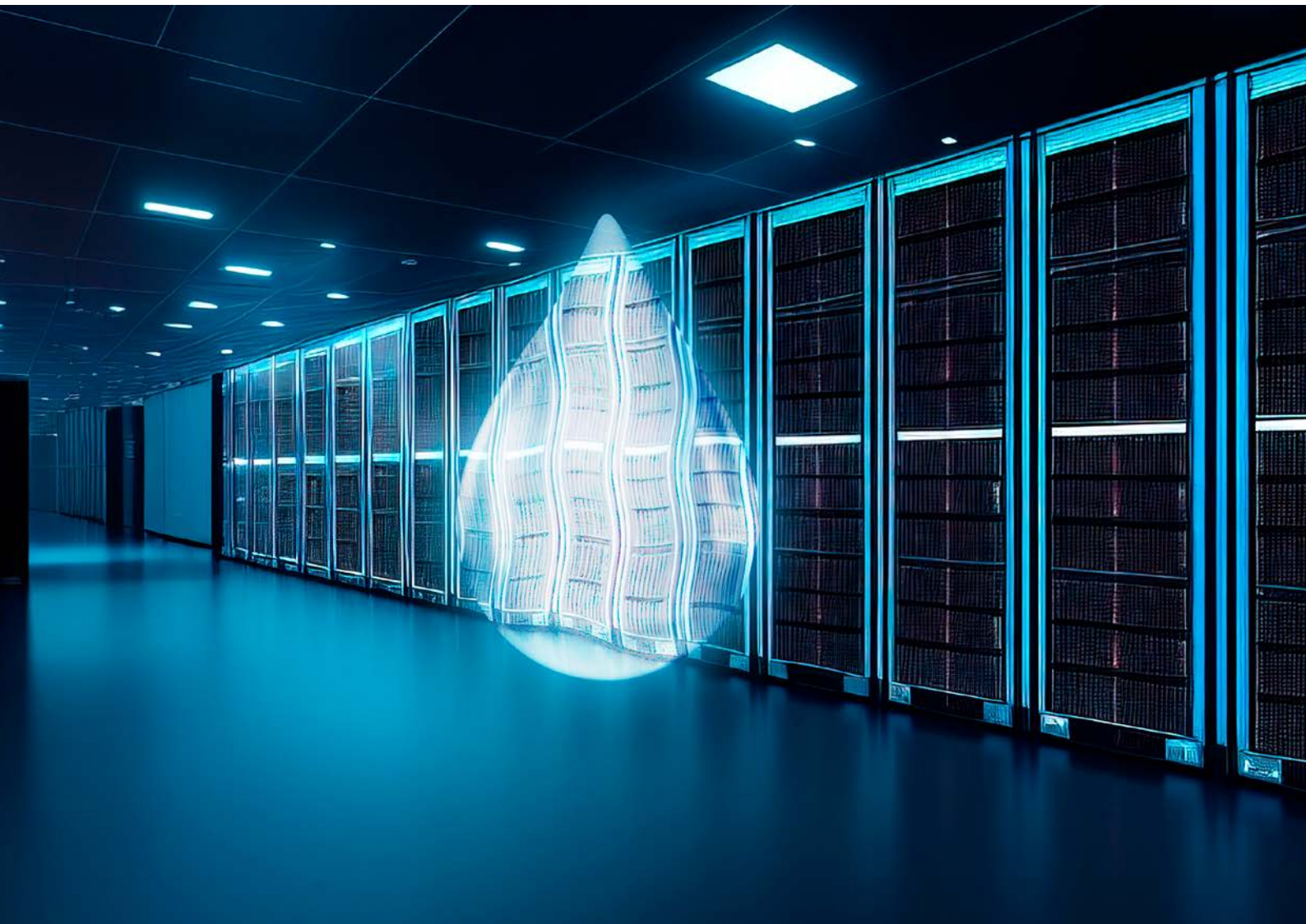

3. Expert Support for Simplifying Design

HVAC solutions for Data Centres demand precision and scalability. Regardless of the Data Centres size, from expansive hyperscale to small-medium facilities, our expert team specialises in customising HVAC system designs to seamlessly integrate with your operations.

New Build Design

When it comes to new Data Centres projects, we collaborate closely with your chosen partners to deliver highly efficient system designs, expertly selecting and integrating HVAC products for a holistic system solution.

Our experts are committed to creating applications that manage increasing demands with an unwavering focus on efficiency and dependability. To optimise design efficiency, we use Building Information Modeling

(BIM) powered by ThorbiQ, which is a web platform, offering a trusted source for consistent BIM content, applications and services. Our BIM Application Suite provides over 550 product options and 1,800 articles, allowing designers to integrate 3D models into their plans easily. We support your entire design lifecycle, from initial planning to on-site execution, ensuring seamless installation and product commissioning whilst maintaining cost-effectiveness.

Prefabricated Data Centres Solutions

In the realm of prefabricated Data Centres solutions, we stand at its forefront with our innovative TA-Smart Valves, Pressurisation, and Water Quality Solutions, setting new standards for efficiency, sustainability and reliability.

Our partnership guarantees flawless integration of HVAC components into your pre-fab systems and your products such as CRAH units and CDUs, emphasising rapid deployment and energy-efficient designs. This approach effectively addresses customisation and size challenges, facilitating smooth project progression, even for applications without on-site welding.

Engineered for optimal performance and adaptability, our products deliver space efficiency and remain fully compatible with the evolving needs of modular prefabricated Data Centres.



HyPerformance Renovation / Retrofit Design

When it comes to renovations, we take a unique approach that prioritises sustainability of Data Centres without compromising efficiency.

Our team will guide you through every step of the process, conducting thorough on-site assessments and taking precise measurements of your HVAC system. By identifying specific challenges, we can develop energy-efficient upgrade strategies that not only minimise costs but also maximise operational performance, reliability and energy efficiency.

Our products are meticulously designed for retrofit applications, taking into consideration size, construction, and ease of commissioning.

This ensures seamless integration into existing applications with a strong focus on adaptability, scalability, and sustainability.

By taking this holistic HyPerformance system approach, we have successfully solved critical performance challenges and reduced energy consumption in buildings by up to 50%.



Reference Cases

Our products and expertise in action

Delivering a High Performant HVAC Solution with High Confidentiality for a Large Technology Company

Project overview:

Our client, a leading large Tech company based in the US, required a high-performing HVAC system that not only met their stringent security standards but also maximised energy efficiency. As a trusted partner, IMI was tasked with delivering a reliable and efficient HVAC system for their Data Centres.

Customer's challenges:

1. Ensure high-efficiency balancing solution for multiple Data Centres.
2. Meet the exceptional security standards and requirements of the client.
3. Collaborate with stakeholders - IMI, the final customer and a leading ventilation equipment manufacturer - to design and implement the optimal solution.

Key Benefits:

1. Enhanced energy efficiency: our solution enabled the client to maximize energy efficiency in their HVAC systems, resulting in reduced operational costs.
2. Exceptional security standards: our advanced balancing solution surpassed the rigorous security standards required by the client.
3. Reliable partnership: we provided ongoing support, ensuring seamless delivery and integration of our valve solution with the client's axial fan coils for cooling CRAC units at the client's Data Centre facilities.

Solution:

To address the client's challenges and unique requirements, our dedicated R&D team worked closely with the Ventilation Engineering team. After a thorough analysis, we recommended the implementation of our TA-Modulator PIBCV valves and the TA Slider actuators.

Results:

Our ability to deliver a high-performing solution whilst meeting the stringent security standards of a leading technology company is a testament to our expertise, collaborative approach, and commitment to customer satisfaction. By providing cutting-edge HVAC solutions, we empower our customers to achieve their business goals whilst optimising energy efficiency and maintaining exceptional security standards.

Achieving Optimal Hydronic Control in CRAC Units in an Existing Australian Data Centres

Project overview:

The client's challenge arose because the chilled water circuit was designed using only isolation valves in the field. Additionally, it incorporated DP remote sensors to enable Variable Speed Drive Chiller control on the main chilled water pumps. With this approach, they relied on a plug-and-play commissioning and self-balancing solution provided by the installed CRAC (Computer Room Air Conditioning) units. Each Power Train Unit (PTU) consisted of 4 CRAC units, resulting in a total of 24x PTUs. These CRAC units are specifically designed to regulate temperature and humidity in computer rooms of Data Centres.

Customer's challenges:

The CRAC units supplier faces the following problems:

1. Stable Differential Pressure Requirement:

CRAC units supplier needs to ensure a stable differential pressure for the CRAC unit's 'VP' control valve. This valve operates based on gas pressure within the refrigeration circuit and must accurately regulate water flow on the plate heat exchanger (water-cooled condenser of the CRAC unit). The proper operation of the CRAC unit depends on maintaining the heat rejection process efficiently.

2. Limitations on Hydronic Solutions and Space:

Despite their expertise, the CRAC unit supplier wasn't allowed to propose any hydronic solution that would require changes to the existing piping network layout of the chilled water system.

As a result, the flow control must be resolved within the limited space provided by the CRAC unit's housing.

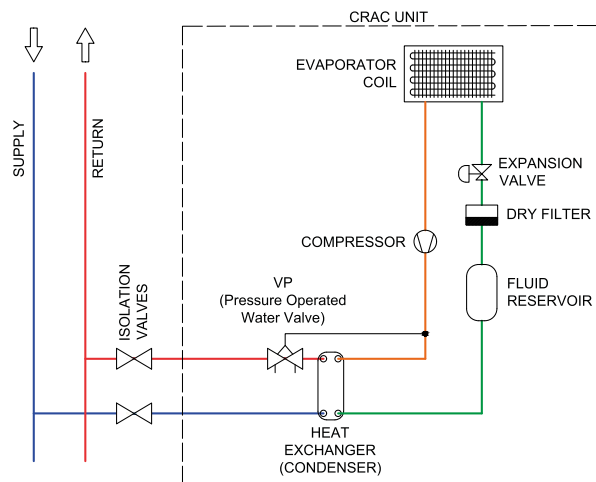

To ensure a high level of control performance, specifically high valve authority for modulation control, it is important to maintain a constant differential pressure (DP) on the control device. This helps accurately regulate the flow rate for the coil and prevents disturbances in the behaviour of the hydronic system, such as differ-

ential pressure fluctuations caused by the operating of control devices. Function of STAP (Differential Pressure Controller): the primary role of STAP is to maintain a practically constant differential pressure (DPL) across the circuit, regardless of changes in the primary differential pressure.

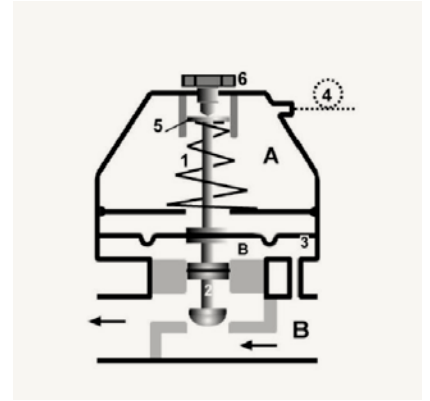
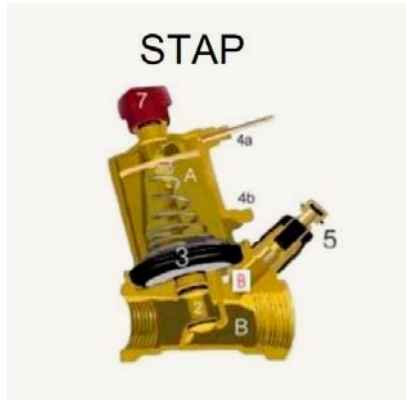
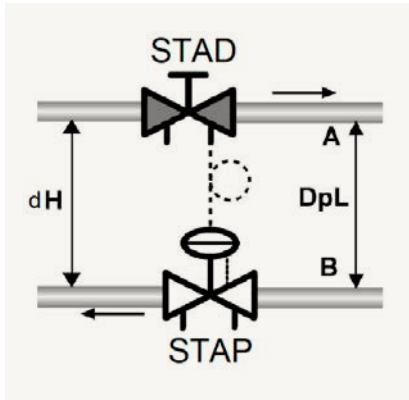

Solution

Our dedicated technical team proposed two solutions incorporating STAP and STAD valves:

Option 1:

STAD Manual balancing valve + STAP Differential pressure controller before the 2-way VP valve and coil

The STAD valve could be commissioned to meet the full load design flow rate of the CRAC unit. The STAP valve is connected to the STAD valve through a capillary line, which monitors the pressure across the condenser heat exchanger. The internal spring of the STAP valve modulates to maintain the differential pressure across the condenser heat exchanger and VP valve.

Option 2:

STAD Manual balancing valve + STAP Differential pressure controller across the 2-way VP valve

The STAD valve could be commissioned to meet the full load design flow rate of the CRAC unit. The STAP valve is connected to the STAD valve through a capillary line, which monitors the pressure across the VP valve. The internal spring of STAP modulates to maintain the differential pressure across the VP valve. Option 2 offers even higher authority and control performance compared to Option 1 because the differential pressure of the coil is not part of the STAP's stabilising differential pressure (DPL). As a result, more effective control performance can be achieved.

Results:

After careful consideration, the client ultimately selected Option 1 due to space limitations inside the housing of the CRAC unit.

This choice ensures a stable differential pressure for the CRAC's unit control valve, maintaining efficient heat rejection without altering the chilled water system's piping network layout.

HVAC Applications

Classification I. (Uptime Institute - Tier I.)

Redundancy: NONE

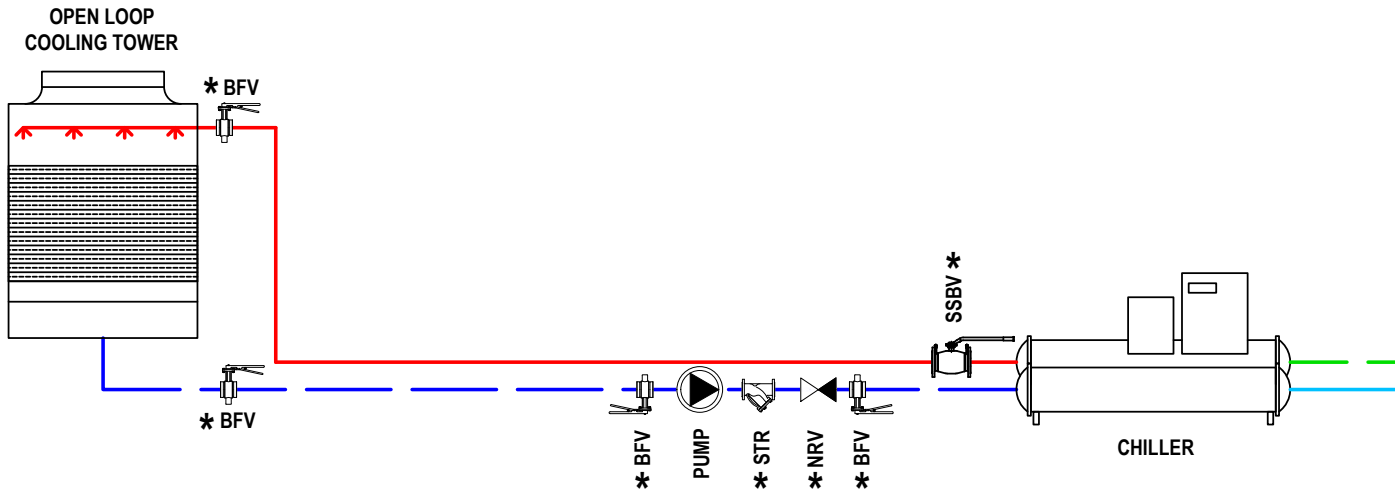

Legend:







— Condenser Water Return

— Condenser Water Supply

— Evaporator Water Return





— Evaporator Water Supply

— Make-up water

-  Butterfly Valve
-  Strainer
-  Stainless Steel Balancing Valve
-  Pump
-  Non Return Valve
-  Microbubble and Dirt Separator
-  2 way electronic differential pressure controller

Tier I. classification requirements:

A Tier I Data Centre is the basic capacity level with infrastructure to support information technology for an office setting and beyond. The facility will have to shut down completely for preventive maintenance and repairs, and failure to do so increases the risk of unplanned disruptions and severe consequences from system failure.

-  Differential Pressure Controller
-  Pressure Maintenance System
-  Softening or Demineralisation Module
-  Back Flow Preventer
-  Balancing Valve

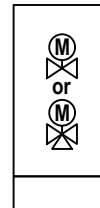

Terminal units can be:

- CRAH (Computer Room Air Handler)
- Row-based cooling
- CDU (Cooling Distribution Unit) with Rear Door Cooling
- CDU (Cooling Distribution Unit) with Direct Chip Liquid Cooling

* For the application in the current system, please contact the local IMI representative

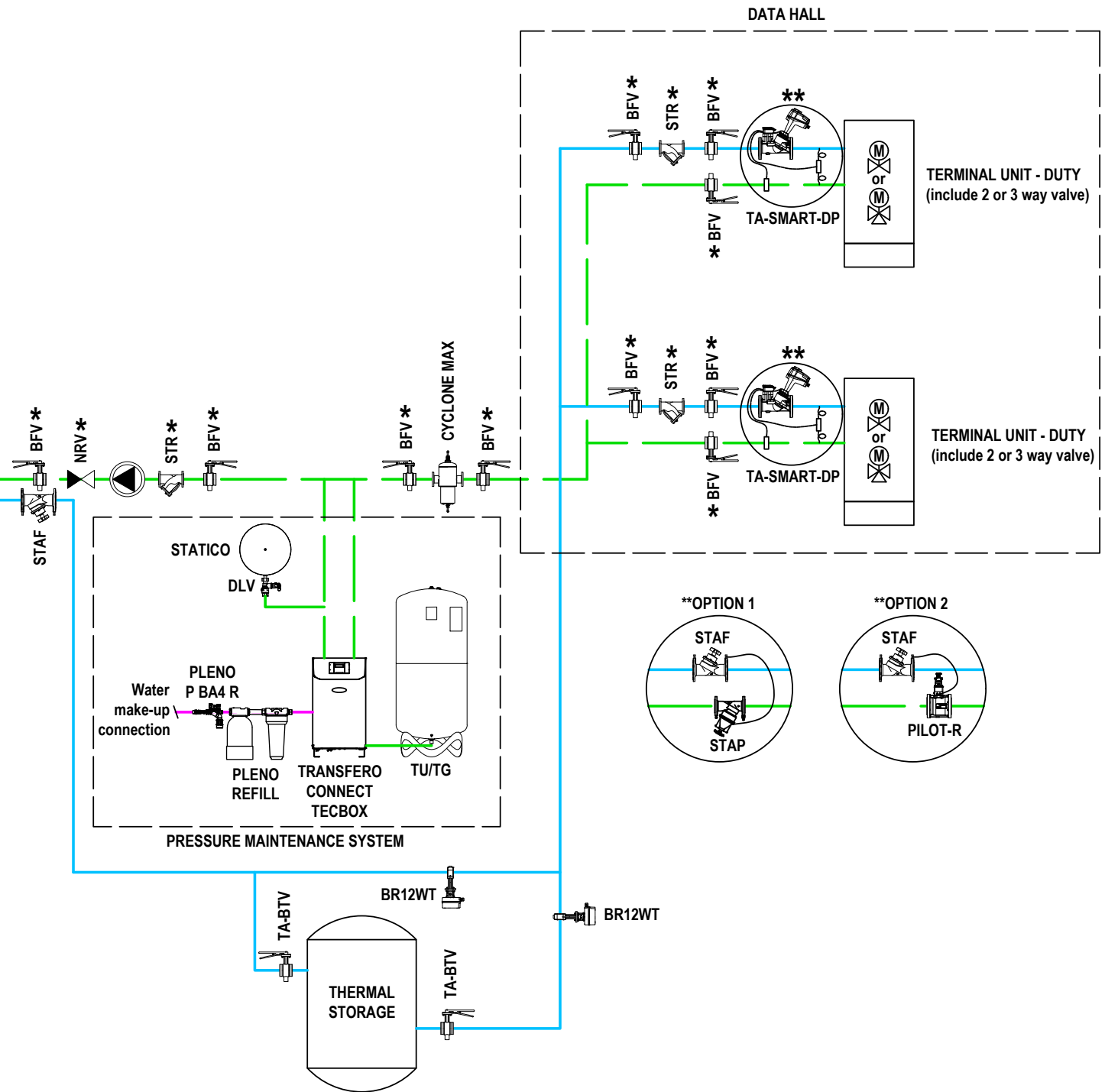

The HVAC system schematics provided serve as illustrations for typical applications in Data Centres. Nevertheless, if you seek tailored solutions precisely aligned with your specific needs and requirements, our expert team stands ready to assist you. Feel free to reach out if you have any questions or would like to engage in a detailed discussion about your project.

Classification II. (Uptime Institute - Tier II.)
 Redundancy: Partial N+1 (Cooling Units)

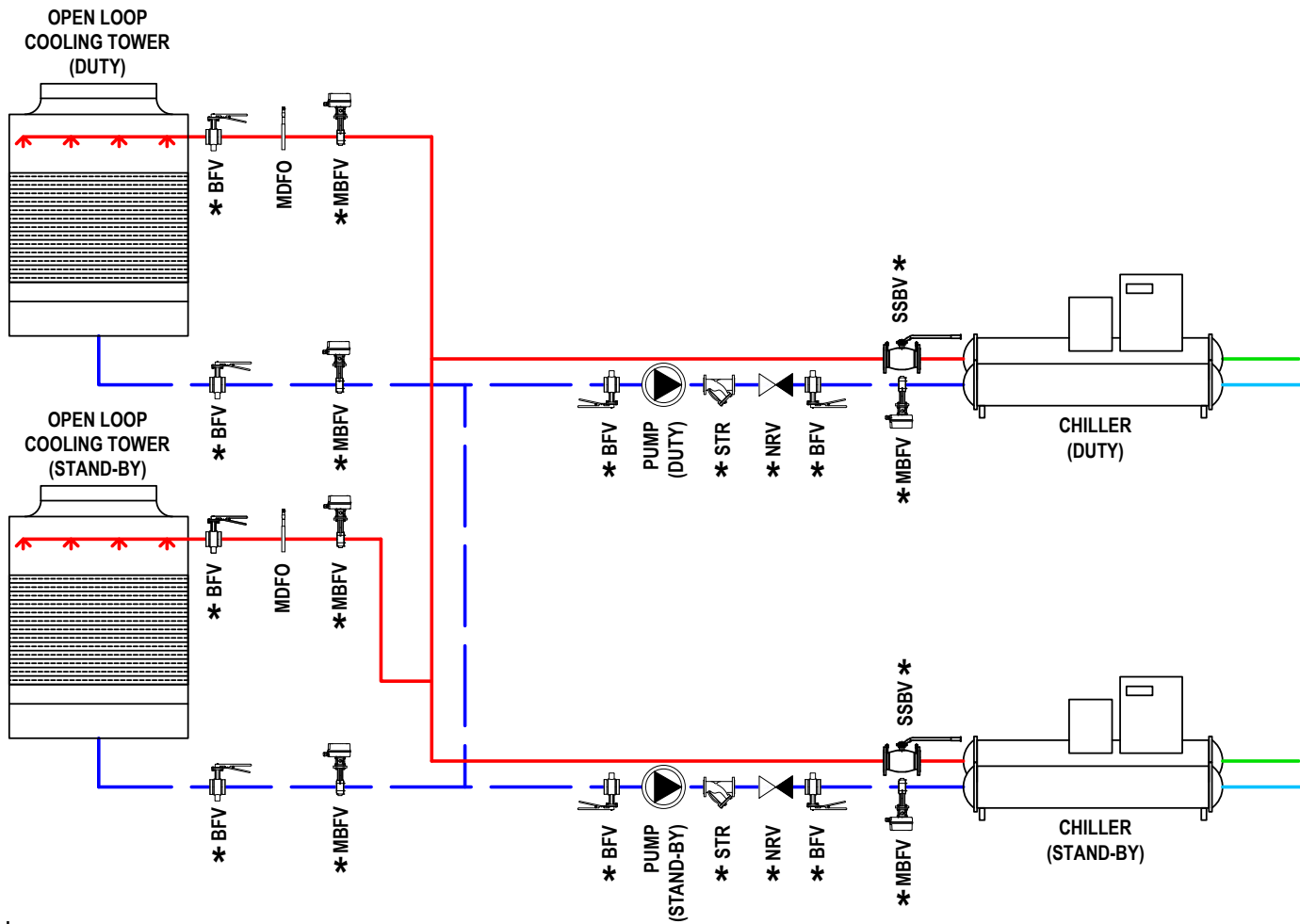

Legend:

- Condenser Water Return
- Condenser Water Supply
- Evaporator Water Return
- Evaporator Water Supply
- Make-up water

- Butterfly Valve
- Measuring Orifice
- Motorised Butterfly Valve
- Strainer
- Stainless Steel Balancing Valve
- Pump
- Non Return Valve
- Microbubble and Dirt Separator

- Differential Pressure Controller
- Pressure Maintenance System
- Softening or Demineralisation Module
- Back Flow Preventer
- Balancing Valve
- 2 way electronic differential pressure controller

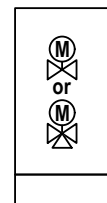

- Terminal units can be:**
- CRAH (Computer Room Air Handler)
 - Row-based cooling
 - CDU (Cooling Distribution Unit) with Rear Door Cooling
 - CDU (Cooling Distribution Unit) with Direct Chip Liquid Cooling

Tier II. classification requirements:

Tier II. facilities cover redundant capacity components for power and cooling that provide better maintenance opportunities and safety against disruptions. The distribution path of Tier II serves a critical environment, and the components can be removed without shutting it down. Like a Tier I facility, unexpected shutdown of a Tier II Data Centre will affect the system.

* For the application in the current system, please contact the local IMI representative

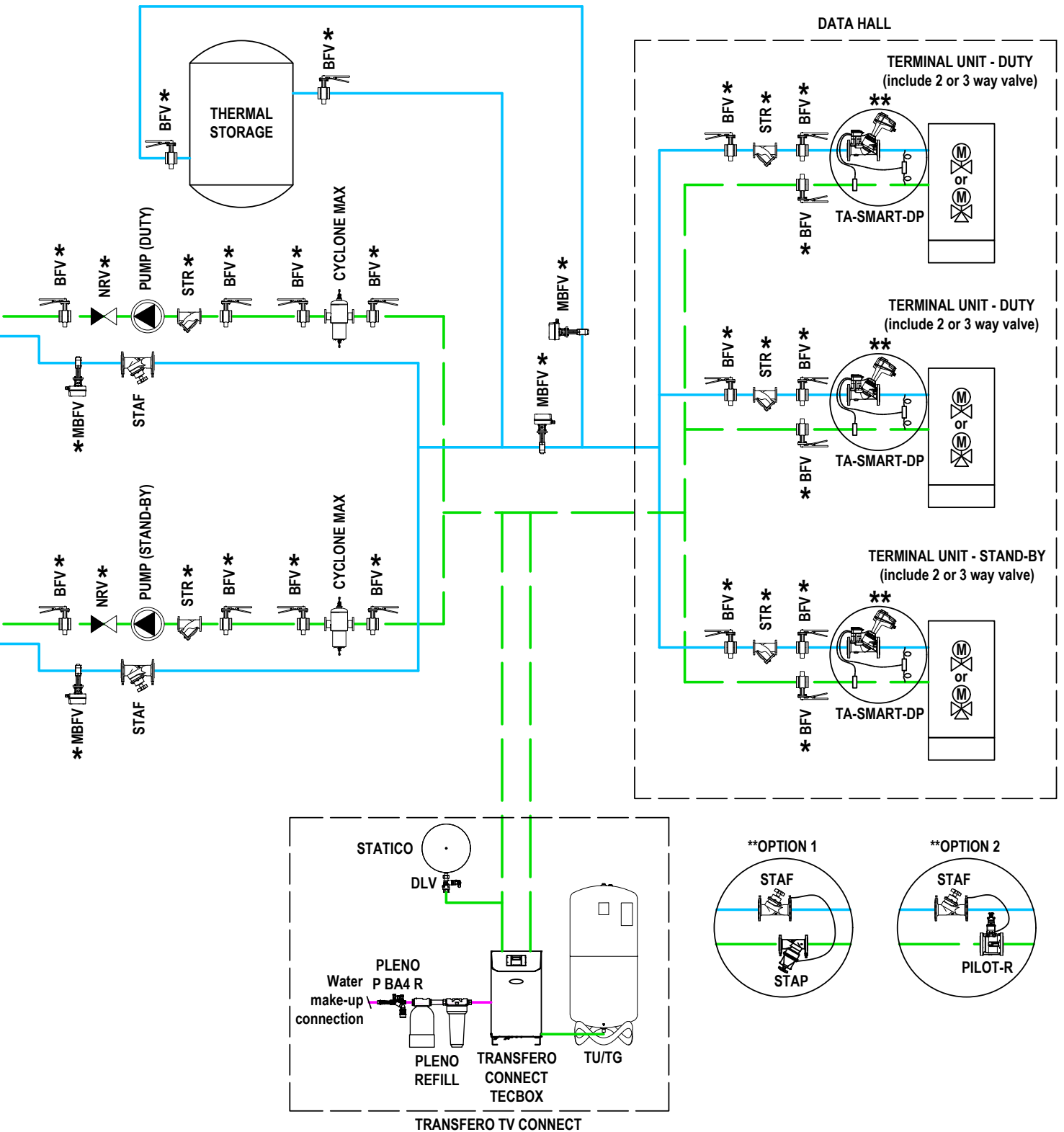

The HVAC system schematics provided serve as illustrations for typical applications in Data Centres. Nevertheless, if you seek tailored solutions precisely aligned with your specific needs and requirements, our expert team stands ready to assist you. Feel free to reach out if you have any questions or would like to engage in a detailed discussion about your project.

Classification III. (Uptime Institute - Tier III.)
 Redundancy: Full N+1

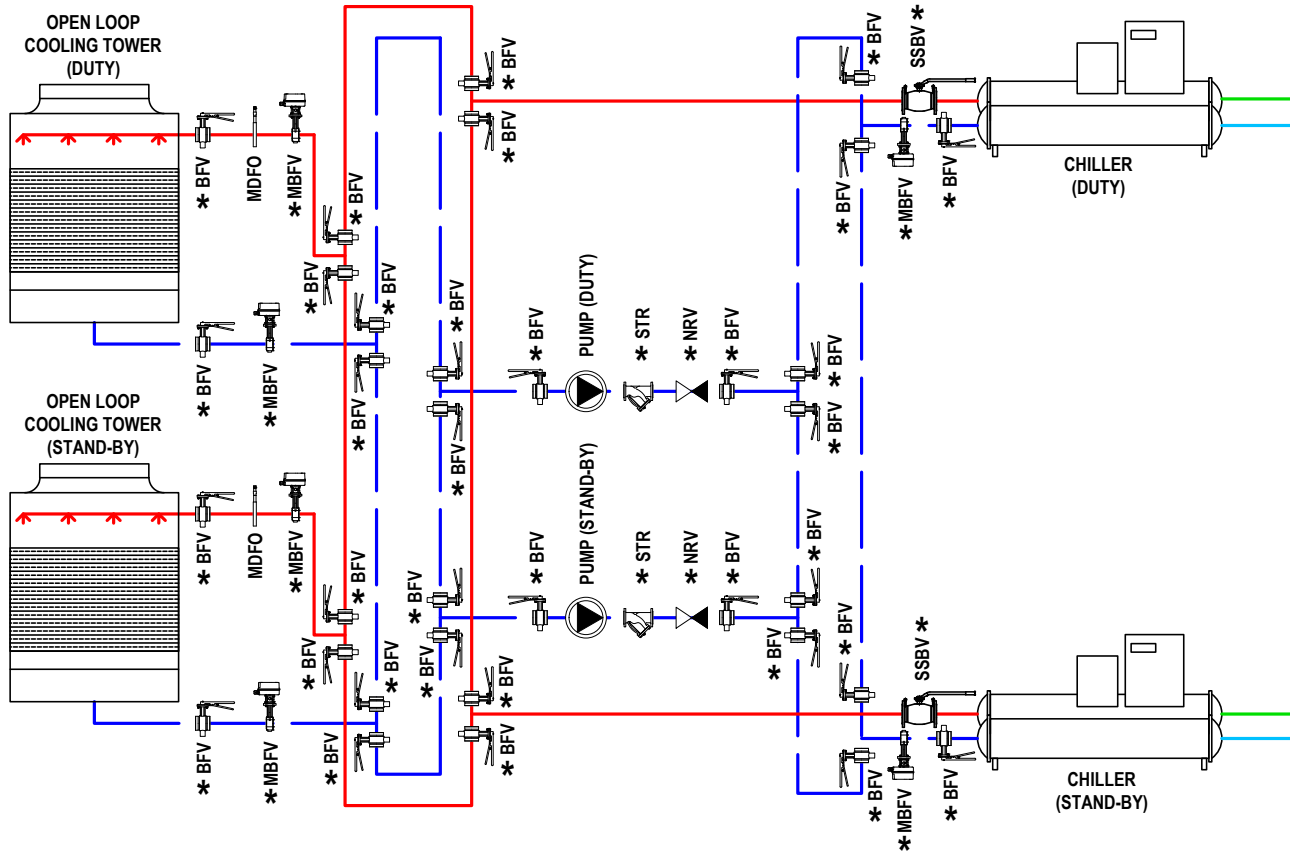

Legend:

- Condenser Water Return
- Condenser Water Supply
- Evaporator Water Return
- Evaporator Water Supply
- Make-up water

- Butterfly Valve
- Measuring Orifice
- Motorised Butterfly Valve
- Strainer
- Stainless Steel Balancing Valve
- Pump
- Non Return Valve
- Microbubble and Dirt Separator

- Differential Pressure Controller
- Pressure Maintenance System
- Softening or Demineralisation Module
- Back Flow Preventer
- Balancing Valve
- 2 way electronic differential pressure controller

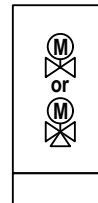

- Terminal units can be:**
- CRAH (Computer Room Air Handler)
 - Row-based cooling
 - CDU (Cooling Distribution Unit) with Rear Door Cooling
 - CDU (Cooling Distribution Unit) with Direct Chip Liquid Cooling

* For the application in the current system, please contact the local IMI representative

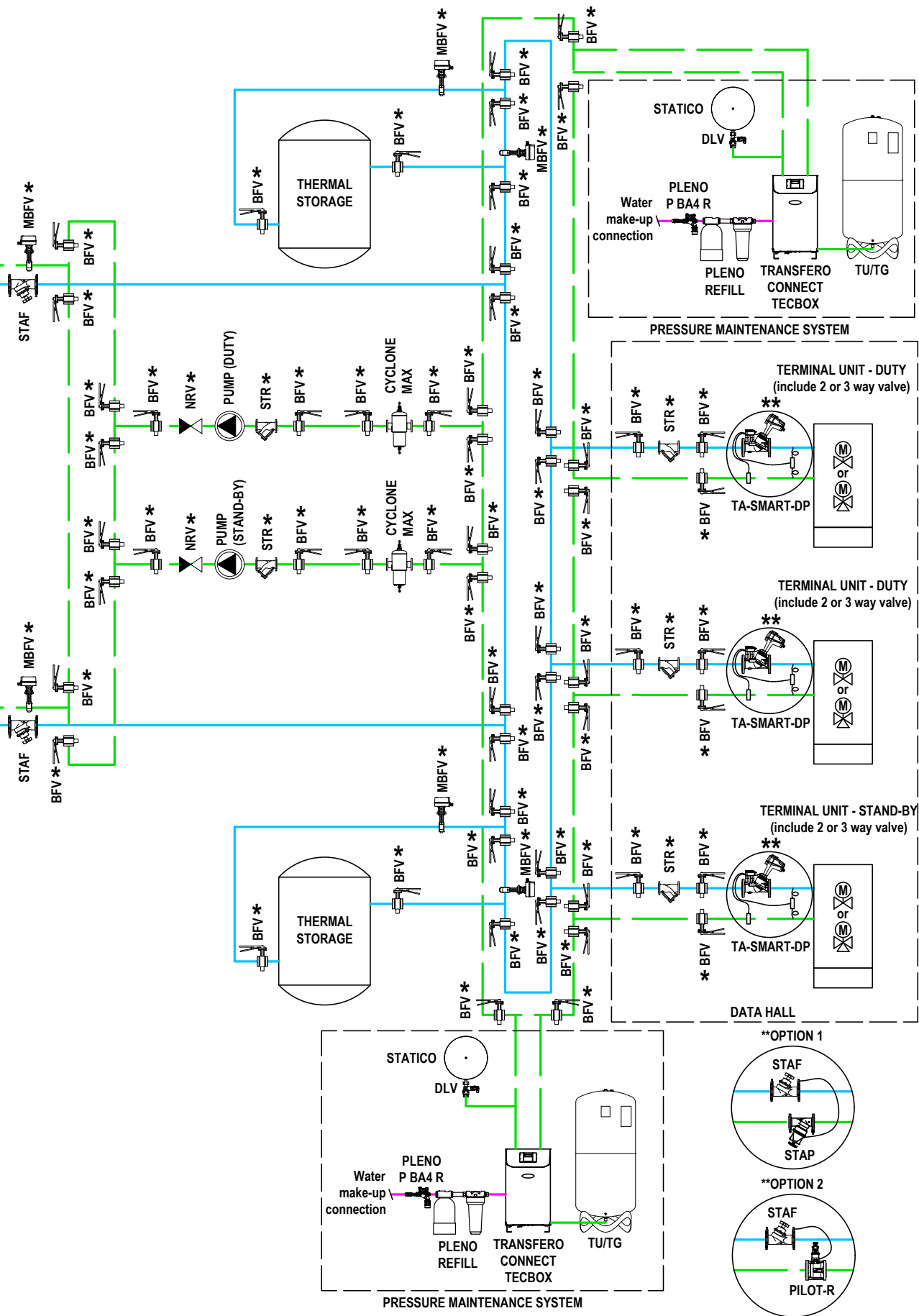

The HVAC system schematics provided serve as illustrations for typical applications in Data Centres. Nevertheless, if you seek tailored solutions recisely aligned with your specific needs and requirements, our expert team stands ready to assist you. Feel free to reach out if you have any questions or would like to engage in a detailed discussion about your project.

Classification IV. (Uptime Institute - Tier IV.)
 Redundancy: 2N

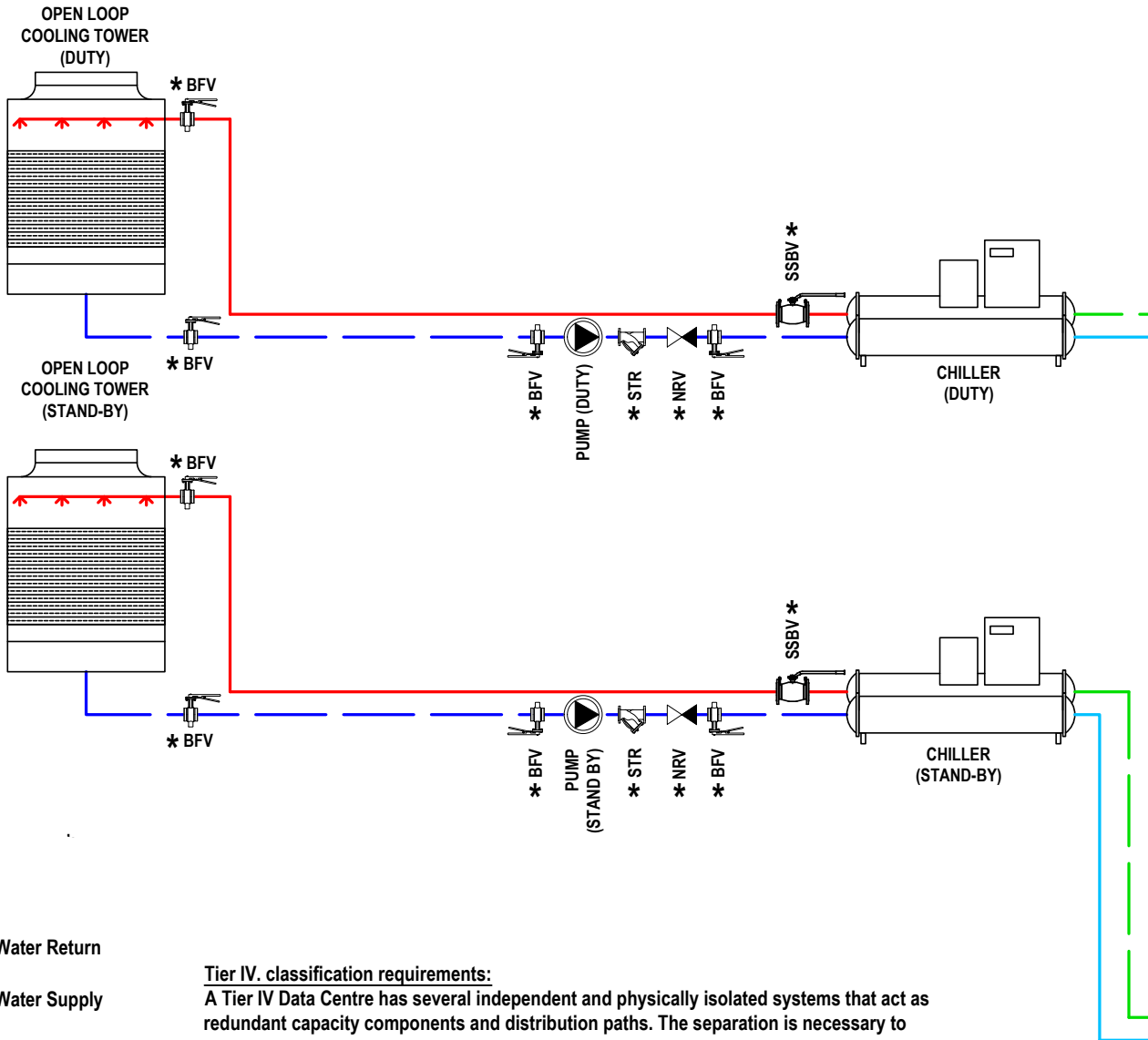

Legend:

- Condenser Water Return
- Condenser Water Supply
- Evaporator Water Return
- Evaporator Water Supply

— Make-up water

- Butterfly Valve
- Measuring Orifice
- Motorised Butterfly Valve
- Strainer
- Stainless Steel Balancing Valve
- Pump
- Non Return Valve
- Microbubble and Dirt Separator

Tier IV. classification requirements:

A Tier IV Data Centre has several independent and physically isolated systems that act as redundant capacity components and distribution paths. The separation is necessary to prevent an event from compromising both systems. Tier IV facilities add fault tolerance to the Tier III topology. When a piece of equipment fails, or there is an interruption in the distribution path, IT operations will not be affected.

- Differential Pressure Controller
- Pressure Maintenance System
- Softening or Demineralisation Module
- Back Flow Preventer
- Balancing Valve
- 2 way electronic differential pressure controller

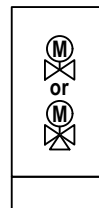

Terminal units can be:

- CRAH (Computer Room Air Handler)
- Row-based cooling
- CDU (Cooling Distribution Unit) with Rear Door Cooling
- CDU (Cooling Distribution Unit) with Direct Chip Liquid Cooling

* For the application in the current system, please contact the local IMI representative

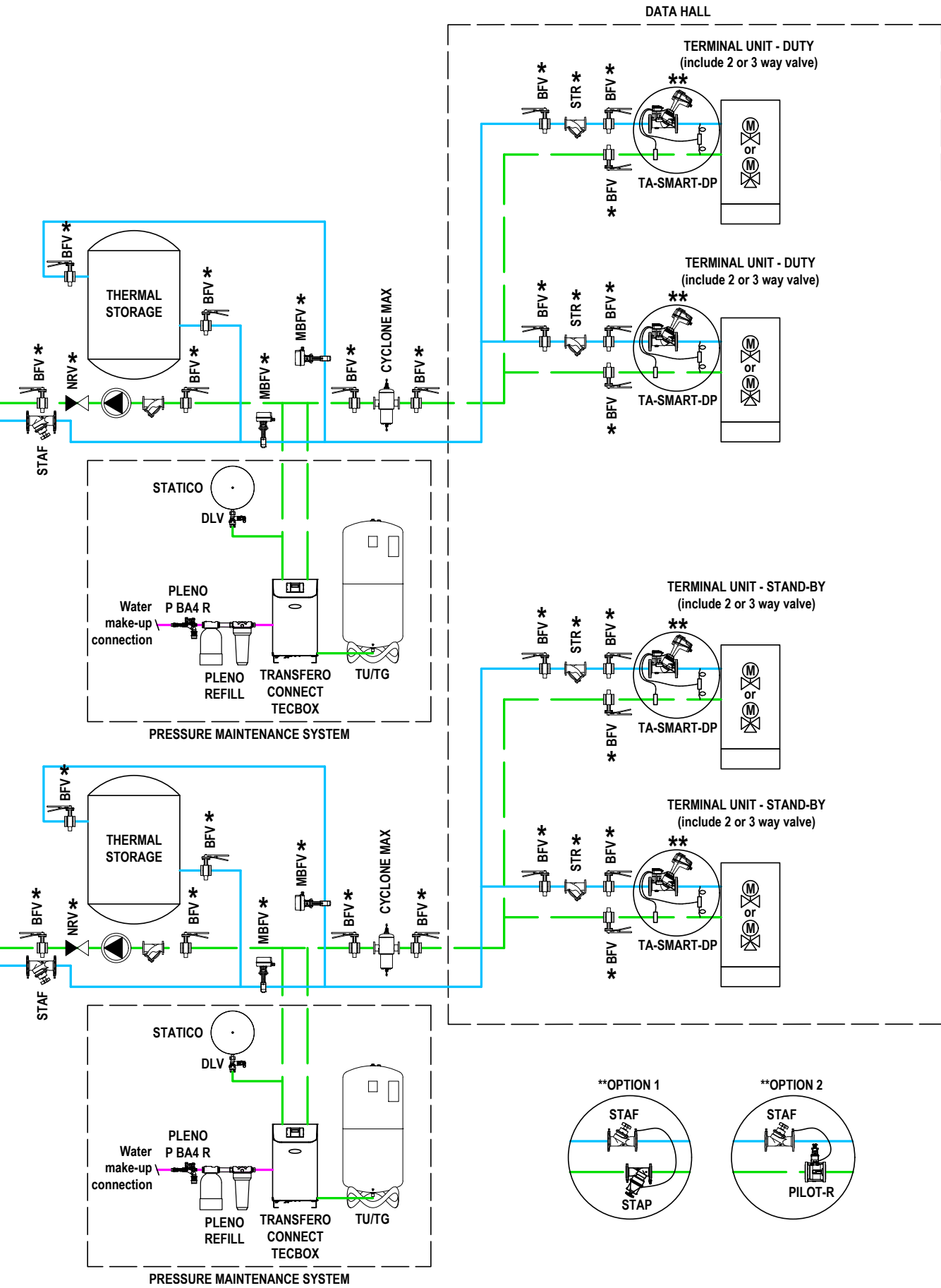

The HVAC system schematics provided serve as illustrations for typical applications in Data Centres. Nevertheless, if you seek tailored solutions precisely aligned with your specific needs and requirements, our expert team stands ready to assist you. Feel free to reach out if you have any questions or would like to engage in a detailed discussion about your project.



Climate Control

Our product brands:
IMI Pneumatex
IMI TA
IMI Heimeier

Climate Control, a Sector of IMI plc

(Legally trading as IMI Hydronic Engineering SA)

Route de Crassier 19

CH-1262 Eysins

Switzerland

EN-11/2024