

# Bolted bonnet, Outside screw-and-yoke, Rising stem handwheel, Swivel disc.

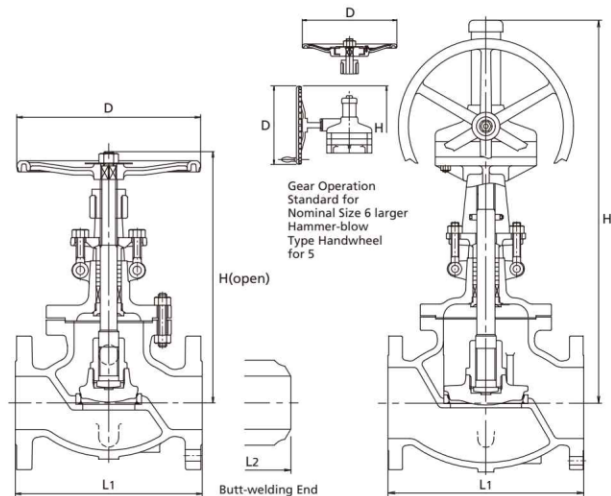

**300SCJS**

**G-300SCJS**

Fig	End Connections
<b>300SCJS</b>	RF-flanged ends.
<b>W300SCJS</b>	Butt-welding ends.

## Standard materials of parts

Parts	Materials
<b>Body</b>	ASTM A216 Gr.WCB
<b>Bonnet</b>	ASTM A216 Gr.WCB
<b>Stem</b>	ASTM A276 Tp.403
<b>Disc</b>	13Cr/Carbon Steel+13Cr
<b>Lock nut</b>	ASTM A182 Gr.F6a
<b>Body seat ring</b>	Carbon Steel+HF*
<b>Gland</b>	ASTM A182 Gr.F6a
<b>Gland packing</b>	Flexible Graphite
<b>Gland flange</b>	ASTM A105/A216 Gr. WCB
<b>Handwheel</b>	Ductile iron
<b>Gasket</b>	See Page 6
<b>Bonnet bolt/nut</b>	ASTM A193 Gr.B7/A194 Gr.2H
<b>Gland bolt/nut</b>	ASTM A576 Gr.1045/A194 Gr.2H
<b>Bonnet bushing</b>	ASTM A182 Gr.F6a
<b>Yoke sleeve</b>	ASTM A439 Tp.D2

\*Hard facing with Co-Cr-W Alloy.

Note: Refer to Page 5&6 for standard seat material and construction.

## Dimensions

Nominal Size		1½	2	2½	3	4	5	6	8	10	12	14	16
		40	50	65	80	100	125	150	200	250	300	350	400
L <sub>1</sub>	in	9.00	10.50	11.50	12.50	14.00	15.75	17.50	22.00	24.50	28.00	33.00	34.00
	mm	229	267	292	318	356	400	444	559	622	711	838	864
L <sub>2</sub>	in	—	10.50	11.50	12.50	14.00	15.75	17.50	22.00	24.50	28.00	33.00	34.00
	mm	—	267	292	318	356	400	444	559	622	711	838	864
H	in	14.2	14.2	16.9	17.2	20.0	24.0	38.9	41.9	45.0	46.7	57.1	55.5
	mm	361	361	428	436	509	610	989	1064	1142	1187	1450	1410
D	in	7.9	7.9	9.8	9.8	13.8	15.7	17.7	19.7	23.6	23.6	23.6	23.6
	mm	200	200	250	250	350	400	500	500	600	600	600	600