

Type EA Electric Actuators/Class 10K Stainless Steel Ball Valves

Fig. EA100/200-UTE

Actuator size: 1 and 1.5
 Valve size: 1/4" to 1" (Reduced bore)



*RoHS

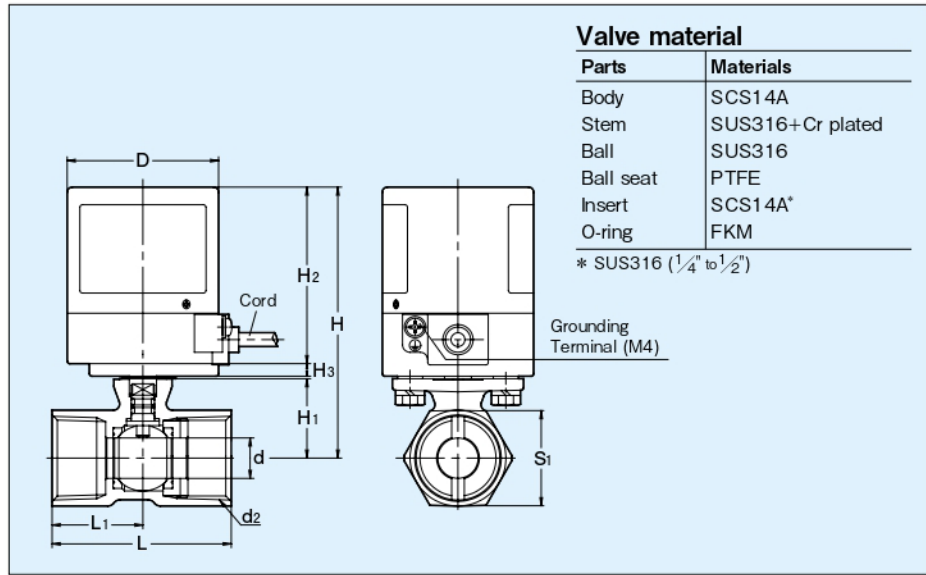

Dimensions

(mm)

Valve Size (inch)	d	d ₁	H	H ₁	L	L ₁	S ₁	Actuator			
								H ₂	H ₃	D	Type
1/4	4.5	Rc1/4	102	26	44	21	21	70	5	60	EA100/200-1
3/8	6.8	Rc3/8	102	26	44	21	21				
1/2	9.2	Rc1/2	102	26	56.5	27.5	25				
3/4	12.5	Rc3/4	105	29	59	30	32				
1	16	Rc1	108	32	71	36	38				EA100/200-1.5

Fig. EA100/200-UTE

Actuator size: 2
 Valve size: 1/4" to 2" (Reduced bore)

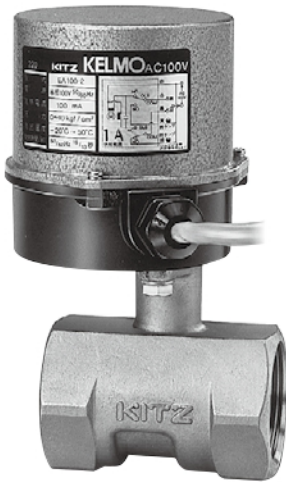

*RoHS

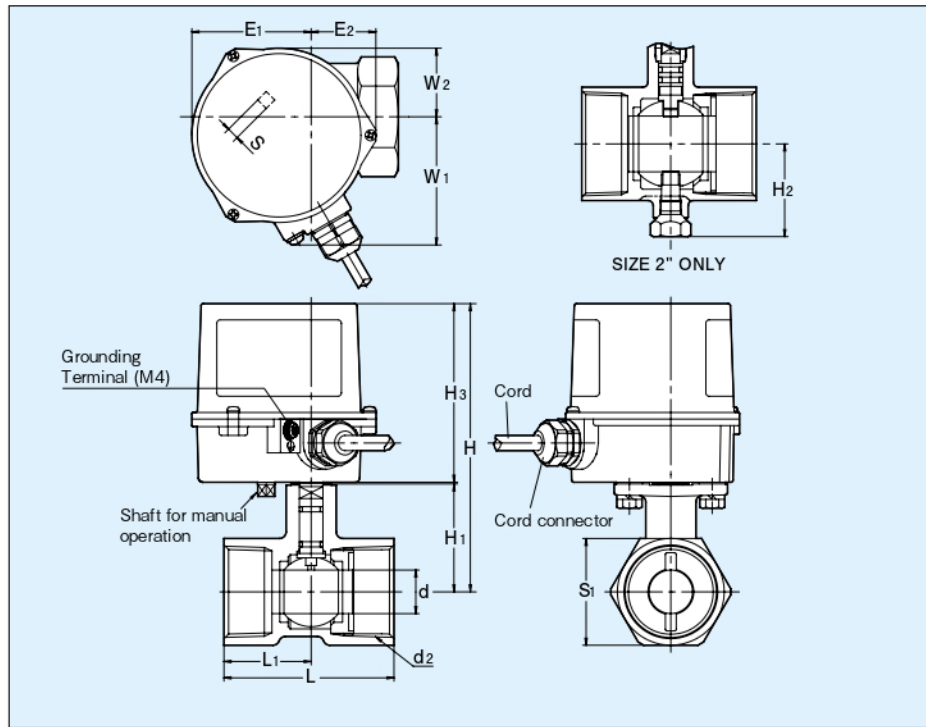

Dimensions

(mm)

Valve Size (inch)	d	d ₁	H	H ₁	H ₂	L	L ₁	S ₁	Actuator						
									H ₃	E ₁	E ₂	W ₁	W ₂	S	Type
1/4	20	Rc1/4	132.5	49.5	—	78	40	49	82	54.5	30	59	31.5	5.5	EA100/200-2
1/2	24.5	Rc1/2	135.5	52.5	—	83	42.5	53							
2	32	Rc2	141.5	58.5	53.5	100	51	65							