

# Type C Pneumatic Actuators/Class 10K Horizontal 3-way Bronze Ball Valves

Fig. C-TNE  
(Standard bore)

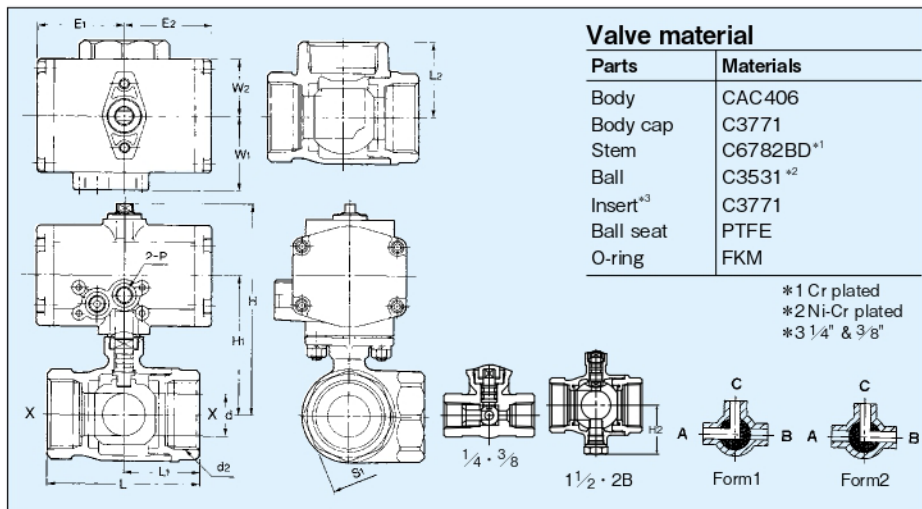

## Valve material

Parts	Materials
Body	CAC406
Body cap	C3771
Stem	C6782BD* <sup>1</sup>
Ball	C3531* <sup>2</sup>
Insert* <sup>3</sup>	C3771
Ball seat	PTFE
O-ring	FKM

\*1 Cr plated  
\*2 Ni-Cr plated  
\*3 1/4" & 3/8"

Note: Refer to page 3 for flow directional forms.

Products are adequately identified with nameplates indicating either one Form 1 or Form 2.

(mm)

## Dimensions

Valve Size (inch)	d	d <sub>2</sub>	H	H <sub>1</sub>	H <sub>2</sub>	L	L <sub>1</sub>	L <sub>2</sub>	S <sub>1</sub>	Actuators					
										E <sub>1</sub>	E <sub>2</sub>	W <sub>1</sub>	W <sub>2</sub>	P	Type
1/4	4.5	Rc1/4	85.5	54	—	46	23	23	21	43	43	34.5	26	Rc1/8	C-1
3/8	6.8	Rc3/8	85.5	54	—	46	23	23	21						
1/2	10	Rc1/2	93.5	62	—	67	33.5	33.5	28						
3/4	15	Rc3/4	97.5	66	—	68	34	34	34						
1	20	Rc1	101.5	70	—	79	39.5	39.5	41	51.4	51.4	44	33.5	Rc1/8	C-2
1 1/4	25	Rc1 1/4	125.5	83	—	89	44.5	44.5	50						
1 1/2	32	Rc1 1/2	138.5	96	53.5	100	50	50	56						
2	40	Rc2	144.5	102	60	115	57.5	57.5	68						