

300UMA

300UMAM

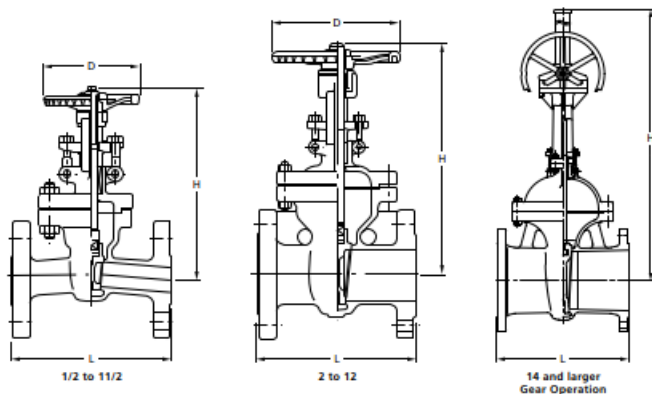

Materials

Parts	300UMA	300UMAM
Body	CF8	CF8M
Bonnet	CF8	CF8M
Stem	304SS	316SS
Disc	CF8	CF8M
Gland	304SS	316SS
Gland flange	Stainless steel	
Gland packing	Refer to Page 10	
Gasket	Refer to Page 10	
Yoke*	Ductile iron	
Yoke sleeve	Ductile Ni-resist	
Handwheel	Ductile iron	
Gland bolt/nut	Stainless steel	
Gland bolt pin	Stainless steel	
Bonnet bolt/nut	B8/8	
Grease nipple**	Stainless steel	
Name plate	Aluminum	

*Yoke is separated from bonnet for size 10 and larger.

**For size 10 and larger

Note: • Body seats and/or disc seats can be optionally hard-faced.

• Flexible wedge for all sizes

Items

Face to face dimensions	ASME B16.10 Class 300
End flange dimensions	ASME B16.5 Class 300
Wall thickness	ASME B16.34 Class 300

Nominal Size		1/2	3/4	1	1 1/2	2	2 1/2	3	4	5	6	8	10	12	14	16	18	20	24
		15	20	25	40	50	65	80	100	125	150	200	250	300	350	400	450	500	600
L	in.	5.51	5.98	6.50	7.48	8.50	9.49	11.1	12.0	15.0	15.9	16.5	18.0	19.8	30.00	33.00	36.00	39.00	45
	mm	140	152	165	190	216	241	283	305	381	403	419	457	502	762	838	914	991	1143
H (open)	in.	8.23	8.66	9.41	11.6	14.0	15.9	18.6	22.1	24.7	29.7	38.1	46.3	54.3	62.60	71.26	77.95	86.22	101.57
	mm	209	220	239	294	355	404	472	560	626	753	968	1177	1378	1590	1810	1980	2190	2580
D	in.	3.94	3.94	3.94	5.51	7.09	7.09	8.86	9.84	11.8	13.8	15.8	17.7	19.7	23.62	23.62	26.77	29.92	35.83
	mm	100	100	100	140	180	180	225	250	300	350	400	450	500	600	600	680	760	910