

20K Strainer for Gas Service

20FDYB

B.C.

RF-flanged

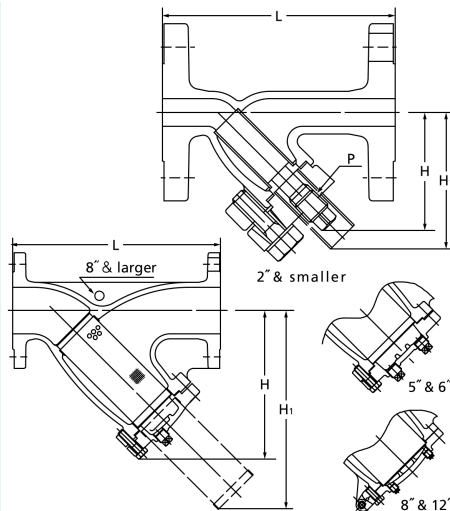
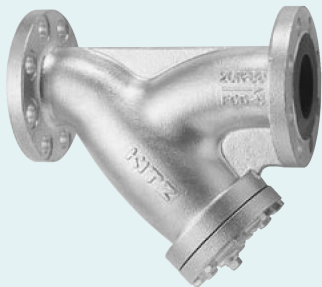

F-F dimension : KITZ Std.
End flanges : JIS B 2239 20K

120°C Static water..... 2.8MPa
220°C Steam, air, gas, oil..... 2.5MPa
300°C Steam, air, gas, oil..... 2.3MPa
350°C Steam, air, gas, oil..... 2.0MPa

- Use for lubricating or hydraulic oil is acceptable.
- A gasket will be used for sealing the plug for application to high temperature exceeding 260 °C . Specify your service temperature in advance. Ensure replacement of plug gaskets on your valve maintenance.

Materials

Parts	JIS material
Body	FCD-S
Cover	FCD-S
Gasket	Flexible Graphite
Screen *	SUS304
Plug	SUS304
Cover bolt	Carbon Steel

* 40mesh wire cloth (reinforced with SUS304 punched plate)

Dimensions

Size	mm															
	mm inch	10 3/8	15 1/2	20 3/4	25 1	32 1 1/4	40 1 1/2	50 2	65 2 1/2	80 3	100 4	125 5	150 6	200 8	250 10	300 12
L	120	125	140	160	185	200	250	305	360	415	465	515	620	760	870	
H	65	65	70	85	124	135	163	222	254	294	335	382	442	548	654	
H1	74	74	85	105	126	139	172	299	345	398	457	508	570	733	895	
P		Rc1/4	Rc1/4	Rc3/8	Rc1/2	Rc3/4	Rc1	Rc1 1/4	Rc1/2	Rc1 1/2	Rc3/4	Rc3/4	Rc3/4	Rc1	Rc1	Rc1

NOTE : For flange dimensions refer to Page 40.