

20K Strainer for Gas Service

20FDY

B.C.

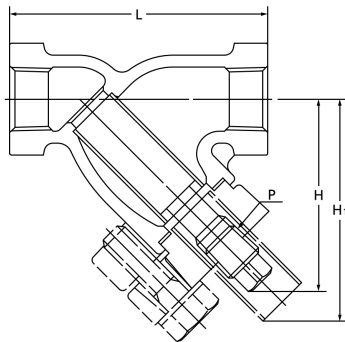
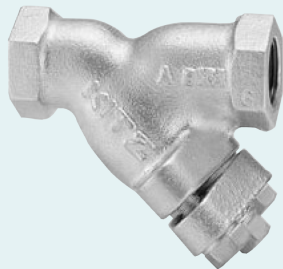

E-E dimension : KITZ Std.
End threads : JIS B 0203

120°C Static water..... 2.8MPa
220°C Steam, air, gas, oil..... 2.5MPa
300°C Steam, air, gas, oil..... 2.3MPa
350°C Steam, air, gas, oil..... 2.0MPa

- Use for lubricating or hydraulic oil is acceptable.
- A gasket will be used for sealing the plug for application to high temperature exceeding 260 °C . Specify your service temperature in advance. Ensure replacement of plug gaskets on your valve maintenance.

Materials

Parts	JIS material
Body	FCD-S
Cover	FCD-S
Gasket	Flexible Graphite
Screen *	SUS304
Plug	SUS304
Cover bolt	S45C

* 40mesh wire cloth (reinforced with SUS304 punched plate)

Dimensions

Size	mm							
	mm inch	10	15	20	25	32	40	50
L		80	85	100	115	135	150	180
H		65	65	70	83	120	130	152
P		Rc ¹ / ₄	Rc ¹ / ₄	Rc ³ / ₈	Rc ¹ / ₂	Rc ³ / ₄	Rc1	Rc1 ¹ / ₄
H1		74	74	85	102	122	134	161