

## Full bore, Split body, Side entry design

### Features

- Antistatic device
- Blowout-proof stem
- Fire test certification\* (API 607, ISO 10497)
- Stem head conform to CAPI ADDS 2.02 dimensions
- High performance **HYPATITE® PTFE** ball seats
- Actuator mounting pad to ISO 5211

- Conform to NACE MR0175 for hardness of body, body cap, stem and ball.

Page 108 for Pressure-Temperature Ratings.

Page 38 for Construction and Materials.

Page 105 for Dimension of Actuator Mounting Pad.

### 150UTDZ(M)/150SCTDZ 300UTDZ(M)/300SCTDZ

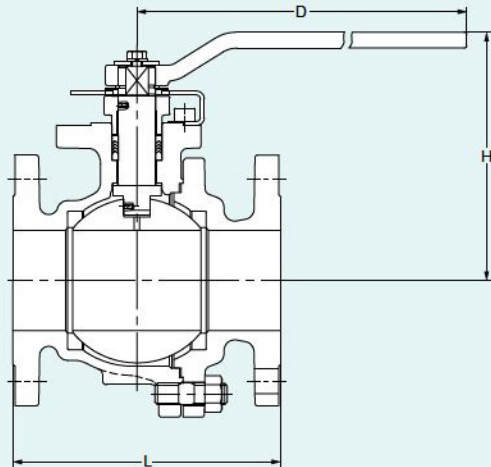

### Dimensions of 150UTDZ(M), 150SCTDZ

Unit: mm

Nominal Size	NPS	1/2	3/4	1	1 1/4*	1 1/2	2	2 1/2	3	4	5	6	8	10
	DN	15	20	25	32	40	50	65	80	100	125	150	200	250
Ball bore		14	19	24	32	38	50	64	76	100	123	151	202	253
L		108	117	127	140	165	178	190	203	229	356	394	457	533
H		108	111	124	128	134	143	179	189	224	240	315	406	Gear operation
D		130	130	160	160	230	230	400	400	460	460	1000	1500	Gear operation

### Valve operator

NPS 1/2 to 8: Lever operation  
 NPS 5 to 8: Optional gear operation  
 NPS 10: Standard gear operation

### Option

★ Flexible graphite packing and gasket  
 (See Pages 8 and 38)

- Ball and stem to 316ss available in carbon steel valves upon request