

Full bore, Split body, Side entry design

Features

- Antistatic device
- Blowout-proof stem
- Double "D" stem head
- High performance **HYPATITE® PTFE** ball seats

Page 111 for Pressure-Temperature Ratings.

Page 39 for Construction and Materials.

150UTB(M)

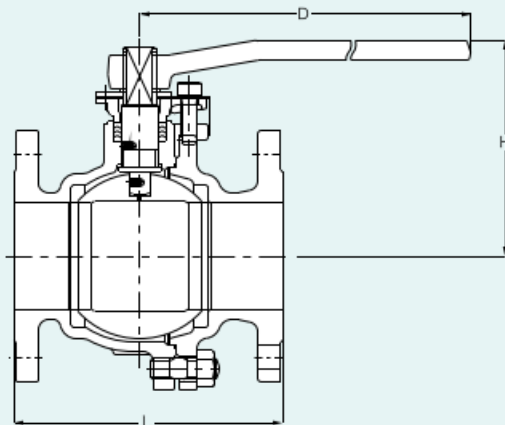

Dimensions of 150UTB(M)

Unit: mm

Nominal Size	NPS	1/2	3/4	1	1 1/2	2	2 1/2	3	4	5	6	8	10
	DN	15	20	25	40	50	65	80	100	125	150	200	250
Ball bore		15	20	25	40	50	65	80	100	125	150	200	250
L		108	117	127	165	178	190	203	229	356	394	457	533
H		102	105	124	115	120	155	165	200	220	295	355	Gear operation
D		130	130	160	230	230	400	400	460	460	1000	1500	Gear operation

Valve operator

NPS 1/2 to 8: Lever operation
 NPS 5 to 8: Optional gear operation
 NPS 10: Standard gear operation