

# Bolted bonnet, Outside screw-and-yoke, Rising stem handwheel, Swivel disc.

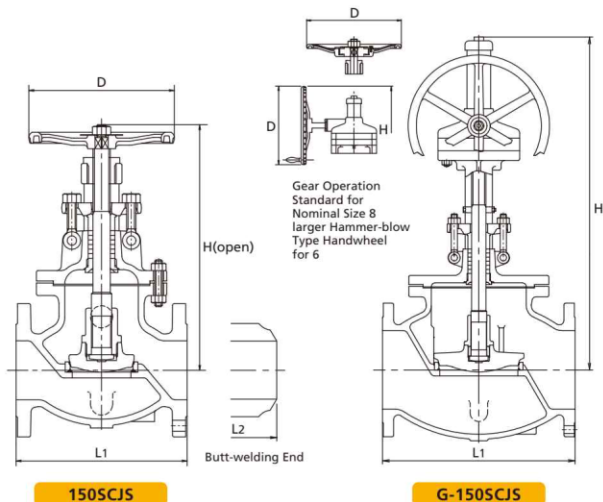

Fig	End Connections
150SCJS	RF-flanged ends.
W150SCJS	Butt-welding ends.

## Standard materials of parts

Parts	Materials
Body	ASTM A216 Gr.WCB
Bonnet	ASTM A216 Gr.WCB
Stem	ASTM A276 Tp.403
Disc	13Cr/Carbon Steel+13Cr
Lock nut	ASTM A182 Gr.F6a
Body seat ring	Carbon Steel+HF*
Gland	ASTM A182 Gr.F6a
Gland packing	Flexible Graphite
Gland flange	ASTM A105/A216 Gr. WCB
Handwheel	Ductile iron
Gasket	See Page 6
Bonnet bolt/nut	ASTM A193 Gr.B7/A194 Gr.2H
Gland bolt/nut	ASTM A576 Gr.1045/A194 Gr.2H
Bonnet bushing	ASTM A182 Gr.F6a
Yoke sleeve	ASTM A439 Tp.D2

\*Hard facing with Co-Cr-W Alloy.

**Note:** Refer to Page 5&6 for standard seat material and construction.

## Dimensions

Nominal Size	Nominal Size												
	1 1/2 40	2 50	2 1/2 65	3 80	4 100	5 125	6 150	8 200	10 250	12 300	14 350	16 400	18 450
L <sub>1</sub>	in	6.50	8.00	8.50	9.50	11.50	14.00	16.00	19.50	24.50	27.50	31.00	38.50
	mm	165	203	216	241	292	356	406	495	622	698	787	978
L <sub>2</sub>	in	—	8.00	8.50	9.50	11.50	14.00	16.00	19.50	24.50	37.50	31.00	38.50
	mm	—	203	216	241	292	356	406	495	622	698	787	978
H	in	13.0	13.0	14.9	15.3	18.0	19.1	20.2	24.8	38.4	41.3	43.5	49.8
	mm	331	331	379	389	458	484	513	929	975	1049	1106	1275
D	in	7.9	7.9	9.8	9.8	9.8	11.8	13.8	15.7	19.7	19.7	23.6	23.6
	mm	200	200	250	250	250	300	350	500	500	500	600	600