

10K Swing Check Valve

10SRBF

B.C.

FF-flanged

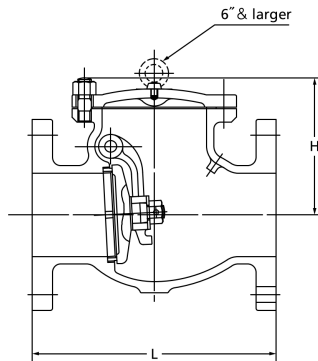

F-F dimension : JIS B 2002
End flanges : JIS B 2239 10K

120°C Static water..... 1.4MPa
220°C Steam, air, gas, oil..... 1.2MPa
300°C Steam, air, gas, oil..... 1.0MPa

- Use for lubricating or hydraulic oil is acceptable. Contact KITZ Corporation for technical advice, if valves are used as heat transfer media.
- Bolting materials will be changed for servicing high temperature exceeding 225°C . Contact KITZ Corporation for detailed information.
- A gasket will be used for sealing the plug for application to high temperature exceeding 260 °C . Specify your service temperature in advance. Ensure replacement of plug gaskets on your valve maintenance.

Materials

Parts	JIS material
Body	FCD-S
Cover	FCD-S
Disc	SUS403 (8"~12" : SCPH2 + 13Cr)
Disc nut	SS400 (5"~12" : SUS304)
Body seat ring	SCS1 (5"~12" : SUS403)
Arm	SCS13A (5"~12" : SFVC2A or SCPH2)
Hinge pin	SUS403
Split pin	SUS304
Plug	SS400
Washer	SS400
Gasket	Soft Steel
Cover bolt / nut	Carbon Steel

Dimensions

Size	mm									
	mm inch	40	50	65	80	100	125	150	200	250
L	165	203	216	241	292	330	356	495	622	698
H	115	120	130	145	160	195	215	255	310	350

NOTE : For flange dimensions refer to Page 40. ※ RF-flanged ends shall be optionally available.