

# 10K Globe Valve

## 10SJBF

S.B.I.S. or U.B.I.S.  
FF-flanged

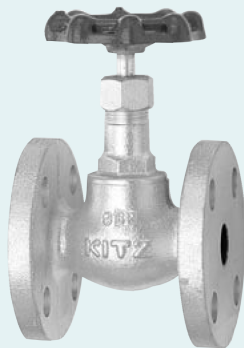

S.B.I.S. for 2" & smaller  
U.B.I.S. for 2 1/2" & 3"

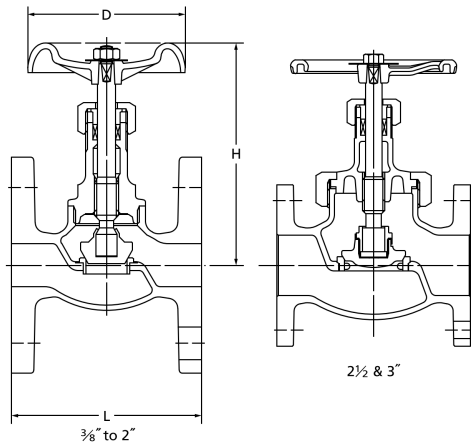

F-F dimension : JIS B 2011 \*  
End flanges : JIS B 2239 10K  
\*KITZ Std. for 3/8"

120°C Static water..... 1.4MPa  
220°C Steam, air, gas, oil..... 1.0MPa

● Use for lubricating or hydraulic oil is acceptable. Contact KITZ Corporation for technical advice, if valves are used as heat transfer media.

## Materials

Parts	JIS material
Body	FCD-S
Bonnet	FCD-S
Stem	SUS420J2
Disc	SUS403
Body seat ring	SUS403
Gland	SUS403 (3/8" ~ 3/4" : SUS420J2)
Gland packing	Non Asbestos Packing
Packing nut	FCD-S
Handwheel	FCD450 (2 1/2" & 3" : FCD400)
Wheel nut	SS400
Gasket	Stainless Foil inserted Flexible Graphite
Bonnet ring	FCD-S
Name plate	A1050P

## Dimensions

Size	mm									
	inch	10	15	20	25	32	40	50	65	80
		3/8	1/2	3/4	1	1 1/4	1 1/2	2	2 1/2	3
L		85	85	95	110	130	150	180	210	240
H (open)		108	122	125	146	160	180	198	250	280
D		60	70	80	90	100	115	135	180	225

NOTE : For flange dimensions refer to Page 40. ※ RF-flanged ends shall be optionally available.