



TML

TRANSDUCERS

2021

Load cells
Displacement Transducers
Pressure Transducers
Acceleration Transducers



INTRODUCTION

Strain gauge type transducers electrically measure physical quantities such as load and displacement. They operate by converting the physical quantities into mechanical stress, and then detecting that stress with a strain gauge. TML offers a number of products according to the item and quantity measured. Since our products use strain gauges, they can be connected to all types of measuring instruments for strain gauges, such as Data Loggers and Dynamic Strainmeters, for taking measurements. This enables capabilities like automatic multiple-point measurement as well as measurement via computer. Our strain gauge type transducers offer a variety of features like compact size, light weight and easy operation, high-precision measurements with excellent linearity and consistency, as well as dynamic measurement capability that is available in many of our products. These features led to widespread use of our strain gauge transducers not only for testing and research, but for control in all types of industrial and civil engineering fields as well. Among these products, transducers recommendable for civil engineering use are guided with the designation.

CHANGES TO THE CATALOG

Changes to this catalog due to product improvements may occur without prior notice.

DIMENSIONS

All dimensions are given in millimeters unless otherwise stated.

PRICES

This catalog does not list product prices. Customers must request a price list separately.

TRANSDUCER HANDLING

Read the Transducer Operation Manual carefully for proper use, and be sure to set up safety measures in case the transducer is damaged by overload or fatigue.

UNITS AND COVERSION FACTORS

Force	1N=0.102kgf	1kN=102kgf	1MN=102tf
Torque	1N·m=0.102kgf·m		
Pressure	1MPa=10.2kgf/cm ²		
Acceleration	1m/s ² =0.102G		

At Tokyo Measuring Instruments Laboratory Co., Ltd. we conduct quality assurance activities based on our company's quality policies to provide customers with the best products that can win their confidence. Products include our company's tangible products, sales activities, installation and measurement services, and all other servicing operations.

ISO9001

In January 1997, we gained ISO9001 accreditation (International Quality Assurance and Management standard) for strain measuring equipment. In January 1999, we gained ISO9001 accreditation for transducer production. Also, strain gauge manufacturing division is added to ISO9001 expanded edition in February 2006. Our goal is to gain ISO9001 accreditation for all company operations. We will further make efforts to achieve this goal and to maintain the system organized and streamlined according to the specifications of ISO9001.



Approval Certificate **ISO9001**
Design and manufacture of
strain gauges, strain measuring
equipment and transducers



Tokyo Measuring Instruments Lab.

8-2, Minami-Ohi 6-Chome, Shinagawa-Ku, Tokyo 140-8560, JAPAN

TEL: +81-3-3763-5614 FAX: +81-3-3763-5713

email address: sales@tml.jp

Your local representative:

INDEX

General description	2
Transducer terminology	3

LOAD CELLS

General Description / How to use / Important Points / Selection	4-6
Compression type Load Cell	
CLS-NA (2 ~ 100N) / CLS-NB (200N ~ 10kN) (CE compliant)	7
CLA-NA (500N ~ 20kN)	8
CLG-NB (10 ~ 200kN)	9
CLP-NB (10kN ~ 10MN) (CE compliant)	10
CLU-NA (10kN ~ 1MN)	11
CLM-NB (10kN ~ 500kN)	12
CLJ-NA (5 ~ 30kN)	13
CLJ-NB (50kN ~ 10MN)	14
CLF-NA (500kN ~ 2MN) (CE compliant) / CLF-NA (3~10MN)	15
CLR-NAH (500N ~ 200kN)	16
CLC-NA (50kN ~ 5MN) (CE compliant)	17
Civil Engineering design	
KCM-NA - Pullout testing and axial force measurement	18
KCE-NA - Strand tension measurement	19
KCH-NA - Strand tension measurement	20
KCC-NA / KCG-NA - Anchoring strand measurement	21
KCK-NA - Strand post-tension measurement	22
CLL-NA / CLH-NA - Concrete loading test	23
Tension/Compression Universal type Load Cell	
TCLZ-NA (10N ~ 10kN) (CE compliant)	24
TCLB-NA (50 ~ 200N) / TCLA-NB (500N ~ 20kN)	25
TCLY-NA (300kN ~ 2MN) / TCLN-NA (500N ~ 5kN)	26
TCLK-NA (5 ~ 50kN)	27
TCLU-NA (10 ~ 200kN)	28
TCLM-NB (10 ~ 200kN) (CE compliant)	29
TCLP-NB (10kN ~ 2MN) (CE compliant)	30
Tension type Load Cell	
TLJ-NA (10 ~ 100kN)	31
TLP-NB (10kN ~ 1MN)	32
3-Component Load Cell	
SLP-NA-T (100N ~ 1kN)	33
Torque Transducers	
LTA-NA (50 ~ 500N·m) / LTB-NA (10N·m ~ 1kN·m)	34
Load Cell Fitting Accessories	35-38

DISPLACEMENT TRANSDUCERS

General Description, Selection, Example of use	39
Displacement Transducers	
CDP (5 ~ 100mm) (CE compliant)	40
CDP-M (5 ~ 100mm) (CE compliant)	41
CDP-B (5 ~ 25mm) / CDP-D (50/100mm)	42
CDP-T (25mm)	43
SDP-E (50/100/200/300mm)	44
SDP-ET (50/100mm) / DDP-A (10~50mm)	45
DP-G (500 ~ 2000mm) (CE compliant) / DP-E (5000mm)	46
FDP-A (10 ~ 100mm)	47
PI (± 2 mm / ± 5 mm) (CE compliant)	48
OU (10 ~ 30mm) / CE (2~10mm)	49
RA/RA-L (2/5mm) (CE compliant) / UB/UB-A (2/5mm) (CE compliant)	50
Displacement Transducers Accessories	51
Contact Tip, Hook Bolt, Holder, Stand, Fixing Jig, Dummy Plate Extensometer	
EDP-A/EDP-B (5mm)	52
Civil Engineering design	
KJA-A/KJB-A - Mass concrete opening displacement	53
KG-A - Concrete crack displacement (CE compliant)	54
KG-B - Concrete crack displacement	55
KLG-A/NKLG-AB - Land slide measurement	56
KLG-B/NKLG-BB - Land slide measurement	57
KLA-A/NKLA-B - Ground level settlement	58
CM/CM-H - Concrete strength testing	59

PRESSURE TRANSDUCERS

General description, Selection, Example of use	60
Measuring hydraulic jack loads	61
Cavity type	
PW-PA (100kPa ~ 50MPa) / PWH-PA (70 ~ 200MPa)	62
PW-PAH (2 ~ 50MPa) / PWFA-PA (2 ~ 20MPa)	63
Flush Diaphragm type	
PWF-PB (1 ~ 50MPa) / PWFC-PB (2 ~ 50MPa)	64
PWFD-PB (2 ~ 20MPa) / PWFE-PA (2 ~ 20MPa)	65
Miniature type	
PDA-PB / PDB-PB (200kPa ~ 3MPa)	66

ACCELERATION TRANSDUCERS

General Description, Selection, How to use	67
ARS-A (10m/s ²) / ARM-A-T (X/Y=100m/s ² , Z=400m/s ²)	68
ARF-A (10 ~ 500m/s ²) / ARF-A-T (X/Y/Z=20 ~ 500m/s ²)	69
ARE-A (1000 ~ 10000m/s ²)	70
ARE-A-T (X/Y/Z=1000 ~ 5000m/s ²)	70
ARH-A (10 ~ 500m/s ²)	71
ARJ-A (50 ~ 2000m/s ²)	
ARJ-A-D (X/Y=50 ~ 2000m/s ²)	
ARJ-A-T (X/Y/Z=50 ~ 2000m/s ²)	72
ARGH-A (500 ~ 2000m/s ²) / ARGH-A (20 ~ 200m/s ²)	73
ARGH-A-T (1000m/s ²)	74
ARGL-A-T (100m/s ²)	75
Acceleration Transducers Accessories	
Mounting Plate	76

TRANSDUCER OUTPUT POLARITY

Civil Engineering design

Soil Pressure at construction site	
KDA/KDB (CE compliant) , KDC/KDD (CE compliant)	78
KDE/KDF (CE compliant) , KDG/KDH (CE compliant)	79
KDJ/KDK (CE compliant)	80
Pore water pressure in ground	
KPC/KPD (CE compliant)	80
Pore water pressure in model testing	
KPE/KPG	81
KPH	82
Level of water in dam, river and under-ground water	
KW-C	82
Inclination/Slope of structures	
KB-AB/KB-AC	83
KB-DB/KP-EB	84
Stress of reinforcing bars arranged	
KSAT-A	85
Internal strain of concrete, synthetic resin	
KM (CE compliant)	86-87
Internal strain of asphalt pavement	
KM-HAS (CE compliant)	87
Friction force on concrete caisson	
KKA-PB	88
Subgrade reaction force of caisson	
KKB-PB	89
Subgrade reaction and elastic modulus	
FWD-Light	90-91

Strain Gauges

Strain measuring instruments	
Static measurements	94-95
Dynamic measurements	96-97

Transducer bridge circuit and connector alignment

Bridge circuit inside and wiring system are given as follows, but not applicable to some products. When connector plug is required, specify it on order to install the plug to the transducer cable.

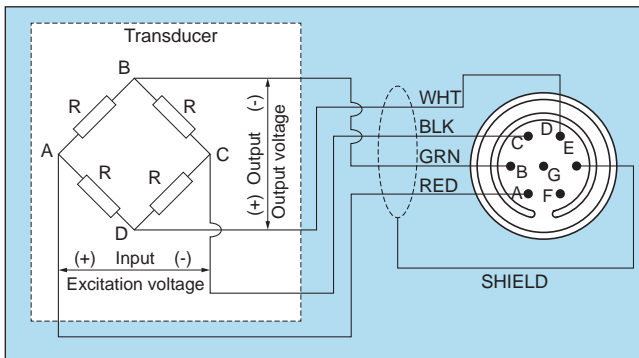

Transducer Input/Output resistance

Input/Output resistance (Ω)	Pin alignment of connector and resistance between cables (Ω)					
	A-C RED-BLK	B-D GRN-WHT	A-B RED-GRN	A-D RED-WHT	B-C GRN-BLK	C-D BLK-WHT
120	120	120	90	90	90	90
350	350	350	263	263	263	263

Measurements with constant voltage method and constant current methods

Constant voltage method

In this method, the bridge excitation voltage (voltage applied between A and C terminals of the strain measuring instrument) is kept constant. Our instruments commonly use this method, and our transducers are usually calibrated using this method. When the transducer cable is extended, sensitivity (calibration coefficient) of the transducer needs correction.

Constant current method

In this method, the bridge excitation current (current flows between A and C terminals of the strain measuring instrument) is kept constant. This method has the advantage that the output of the transducer does not decrease even if the transducer cable is extended. However, the input/output resistance of the transducer must be a specified value (usually, 120 or 350 ohm). It must also be noted that the sensitivity (calibration coefficient) of the transducer may differ for constant voltage method and constant current method.

Rated output and strain value

The output (rated output) of a transducer is expressed as mV/V. It is the output voltage when a maximum load is applied to the transducer. It shows the output voltage generated when 1V is applied.

Example:

1.5mV/V means that 1.5mV is output when a load of the transducer's full capacity is applied while 1V is applied as bridge excitation. If 2V is applied (bridge excitation of a strain measuring instrument):

$$1.5\text{mV/V} \times 2\text{V} = 3\text{mV}$$

Therefore, if the gauge factor is set at 2.00 (coefficient set at 1.000) the output voltage of the transducer is 3mV and the value to be shown on a strain measuring instrument can be calculated by the following expression, which is formulated based on the voltage-to-strain relational expression:

$$\Delta e = E/4 \times K \times \epsilon$$

$$\epsilon = 4\Delta e/KE$$

where, Δe : Output voltage (V) of a transducer

E : Excitation voltage (V)

K : Gauge factor of a strain measuring instrument

ϵ : Reading on a strain measuring instrument

With K, E and Δe defined as 2.00, 2V, and 3mV, respectively, 3mV is equal to 0.003V and therefore,

$$\epsilon = 0.003 = 3000 \times 10^{-6} \text{ strain}$$

By setting the gauge factor of a strain instrument at 2.00 and expressing the output voltage of a transducer at 1V excitation, we have the following:

$$2\Delta e = \epsilon, \text{ then}$$

$$1\text{mV/V} = 2000 \times 10^{-6} \text{ strain}$$

$$2\text{mV/V} = 4000 \times 10^{-6} \text{ strain}$$

Decreased sensitivity due to a long cable used to connect to a transducer

When a measuring instrument with constant voltage method is used and the transducer cable is extended from the original cable used for the calibration (shown in the test data), the output of the transducer is decreased. The output (calibration coefficient) will be as in the following formula. Correction should be made using this formula when necessary.

$$\epsilon_s = \epsilon_m \times \frac{R}{R+r \times L}$$

ϵ_s : Corrected output (calibration coefficient)

ϵ_m : Original output (calibration coefficient) given on the test data

R : Input resistance (Ω) of the transducer

r : Total resistance of the input side of the extended cable per meter (Ω/m)

L : Length of the longer cable (m)

Resistance per meter of a cable used to connect to a transducer

Cross section area (sq. mm)	Total resistance per meter (Ω)
0.005	7.2
0.05	0.63
0.08	0.44
0.09	0.40
0.14	0.25
0.3	0.12
0.35	0.11
0.5	0.07
0.75	0.048

TEDS support

TEDS is an abbreviation of Transducer Electronic Data Sheet. A TEDS compatible transducer has sensor information conforming to IEEE1451.4 as electronic data inside. It enables automatic input of sensor information including the sensitivity and serial number into the measuring instrument. This automation eliminates wrong settings, significantly reduces the time required for settings and realizes efficient and simple works.

For more details of TEDS compatible transducers and measuring instruments, please contact us.

Transducer terminology

Capacity

Maximum load that a transducer can measure and still maintain specifications.

Rated Output (RO)

Output at the rated load minus output under no-load conditions. Rated output is expressed per volt applied to the transducer (mV/V).

Non-linearity

Maximum distance of the transducer's output from a line connecting the calibration curve origin and the rated load point with increasing loads. Non-linearity is expressed as a percentage of rated output (%RO).

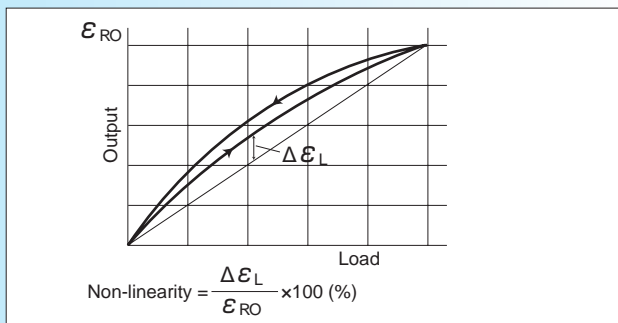

Hysteresis

Maximum difference between transducer output with increasing and decreasing loads. Hysteresis is expressed as a percentage of rated output (%RO).

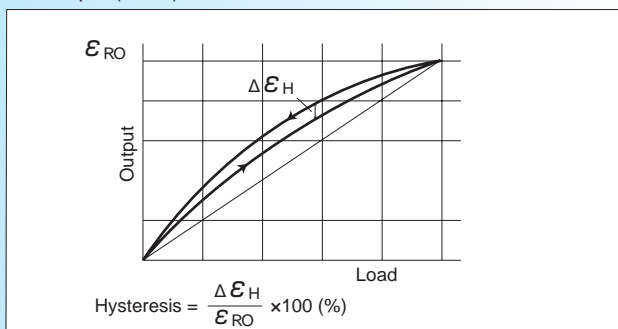

Repeatability

Maximum difference in output when the same rated load is measured repeatedly under identical load and environmental conditions. Repeatability is expressed as a percentage of rated output (%RO).

Temperature effect on zero

Transducer output due to changes in ambient temperature. Temperature effect on zero expresses change per degree of ambient temperature as a percentage of rated output (%RO/°C).

Temperature effect on span

Rate of change in rated output due to changes in ambient temperature. Temperature effect on span is expressed per degree of ambient temperature (%/°C).

Compensated temperature range

Range of temperatures compensated for temperature effect on zero and span. (°C).

Allowable temperature range

Range of temperatures that can be applied continuously without causing permanent destructive change to the transducer (°C).

Overload

Load that can be applied continuously without causing permanent destructive change exceeding specifications (%).

Ultimate overload rating

Maximum load that can be applied continuously without causing permanent destructive change mechanically (%).

Recommended exciting voltage

Voltage that can be applied to the transducer and still maintain specifications (V).

Allowable exciting voltage

Maximum voltage that can be applied continuously to the transducer without causing permanent destructive damage (V).

Zero balance

Output strain while unloaded (%RO)

Frequency response

Maximum frequency at which the transducer can output within a specified range using a sine wave load (Hz).

Natural frequency

Approximate frequency under no-load conditions at which a transducer oscillates freely (Hz).

Allowable bending moment

Maximum bending moment that can be applied continuously to the transducer without causing permanent destructive damage (kN·m).

Sensitivity

Transducer output with a fixed load. Sensitivity expresses strainmeter output per millimeter ($\times 10^{-6}$ strain/mm) when the strainmeter coefficient on the displacement transducer is set at 1.000 (2.00 gauge factor fixed).

Gauge length

Distance between two points used to measure displacement or strain.

Spring force

Approximate force required to displace capacity on the displacement transducer (N).

Input/Output resistance

Resistance between input and output terminals measured under no-load conditions with input and output terminals disconnected (Ω).

Input/Output cable

Cable that cannot be disconnected from the transducer.

Supplied cable

Standard cable accessory that can be disconnected from the transducer.

Weight

Approximate weight of the main unit minus I/O cable and cable accessories.

About IP ratings

A classification system rates how well enclosures and package for electrical components seal against intrusion by foreign materials such as dust and moisture. It conforms to JIS C0920, or IEC 60529, and entails various levels of ingress protection afforded against solid objects and water.

LOAD CELLS

TML load cells are used to convert force and load to electrical signals. The detecting element for force and load is a strain gauge that TML developed especially for load cells. With our extensive field-proven record and experience applied to structures and materials in all load cell areas, our cells have earned widespread trust as high-precision products offering excellent consistency and durability. Our line includes a number of compression, tension and tension/compression universal models with high to low capacities. Since our load cells are so widely used, we also offer all types of products related to load cells that allow customers to choose exactly what they need for their particular purpose. In addition to load cells, we also carry a line of products for measuring torque, such as torque transducers for socket wrenches, etc.

OUTPUT POLARITY WITH A LOAD

The measured value changes in negative (-) direction with increase of compressive force. It changes in positive (+) direction with increase of tensile force. (This does not apply to KCK-NA load cell.)

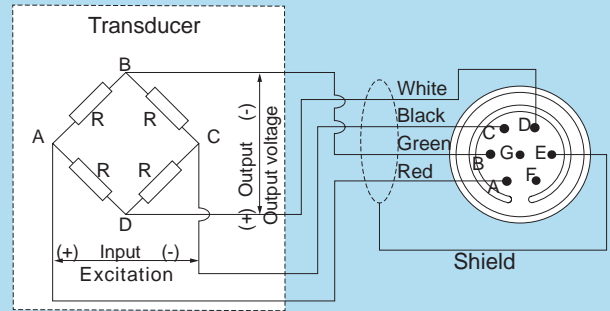

Not applicable to some products.

HOW TO USE

Fatigue test

Measuring a load in material fatigue testing using load or displacement parameters

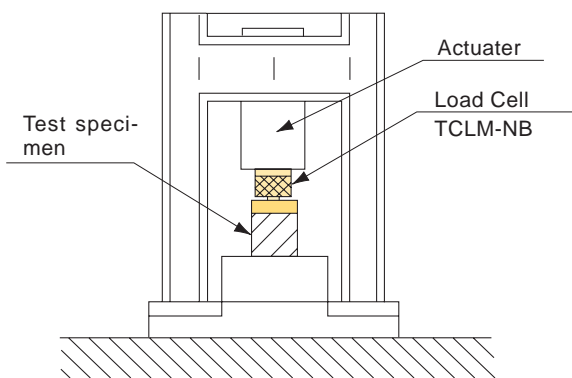

Ground and Rock anchors

Measuring force on steel bar or wire for PC -Pre-stressed concrete - like ground anchors and rock anchors

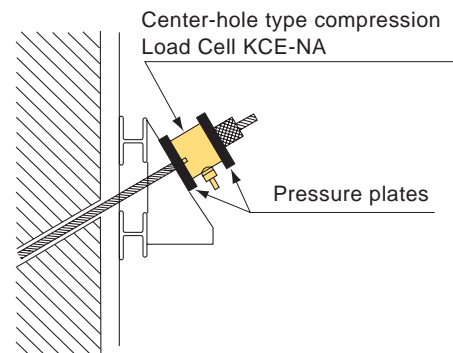

Loading test

A load test on concrete column specimen

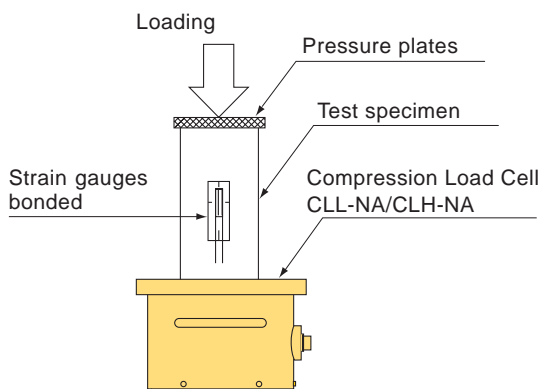

Suspension force

Measuring weight with a load suspended by crane

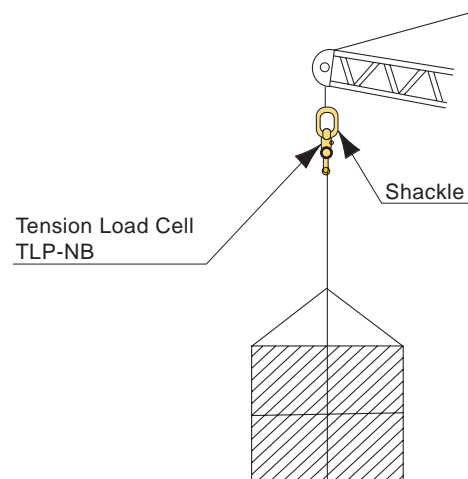

Important Points

The load cell is a transducer to detect the load which is directly applied to the load cell itself. Therefore, the load cell itself has to be treated as part of the structure. The load cell is calibrated to vertical load in

the sensing direction. Eccentric load, transverse load, bending or shearing force may deteriorate accuracy and in the worst case cause damage.

■ In case of compression use

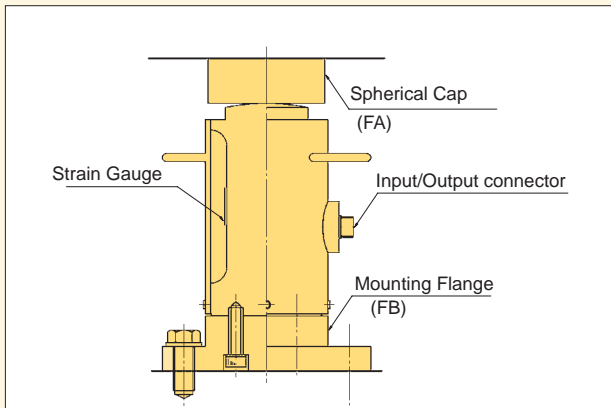

- A structure where a load cell is installed must sufficiently withstand loading. The base must be deformation or deflection free due to loading. In addition, the contact pressure of the bottom of load cell should be noted.
- The load cell should be installed so that the load can be applied vertically to the load cell. The top of load cell is so spherical that bending moment or distortion is not applied to the load cell. The use of a spherical cap is recommended.
- As the need arises, set up a safety device for breaking of the load cell.
- Load cell accessories such as spherical cap and mounting flange are available.
- In case the load cell is used for impact testing, larger capacity load cell has to be selected considering its shock acceleration component. In case of cyclic loading such as fatigue life test, the applied load should be 1/2 or less of the load cell capacity.
- All load cells are self-temperature-compensated, but a sharp temperature variation makes the output instable. Take note not to receive direct sunlight.

■ In case of tension use

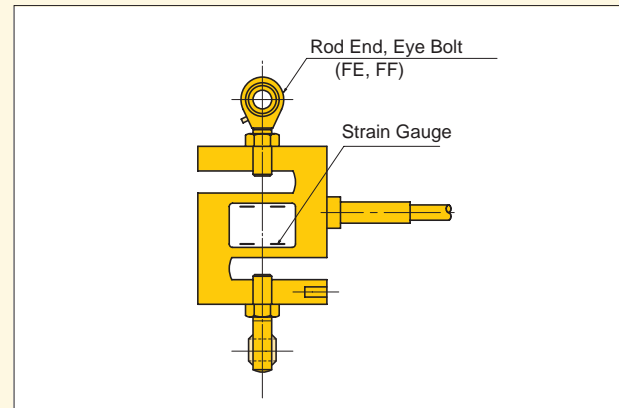

- In case the tension/compression load cell is used for tension, force is received by the screw thread. The strength of the thread is very important, and if fully loaded up to the rated capacity, stress at the thread becomes high. Therefore, a screw thread with 8 to 10 in strength gets necessary.
- For lifting load measurement, a measure for preventing the screw from rotating should be taken. In addition to high safety ratio, some safety device in case of breaking of the load cell should be also taken into account.
- Load Cell accessories such as Rod End and Eye Bolt are available.
- The load cell has hermetically sealed structure but the use in adverse environments may badly influence its waterproofness and corrosion resistance. Please consult us.
- The shield of the load cell cable is not connected to the load cell body. For noise protection, connect the shield to the E (earth) terminal of a measuring instrument.

Load Cells for Material Testing Machine

JIS B 7728

The force measuring system used for the calibration is this load cell. The load cell has to be calibrated in accordance with Japanese standard JIS B 7728 "Calibration of force-proving instruments used for the verification of uniaxial testing machines". The load cell conforms to JIS B 7728 and meets its requirement in accuracy, and has rod end and bearing plate as loading jigs. The load cell is produced according to the capacity, accuracy class and shape of a testing machine for calibration.

FEATURES

- ▶ Conforms to JIS B 7728:2013
- ▶ JIS B-7728 is based on ISO376:2011, Metallic materials - Calibration of force-proving instruments used for the verification of uniaxial testing machines (MOD), and thus it conforms to ISO376.
- ▶ For compression and tension
- ▶ Capacity at your option
- ▶ With loading jigs
- ▶ Remote sensing available

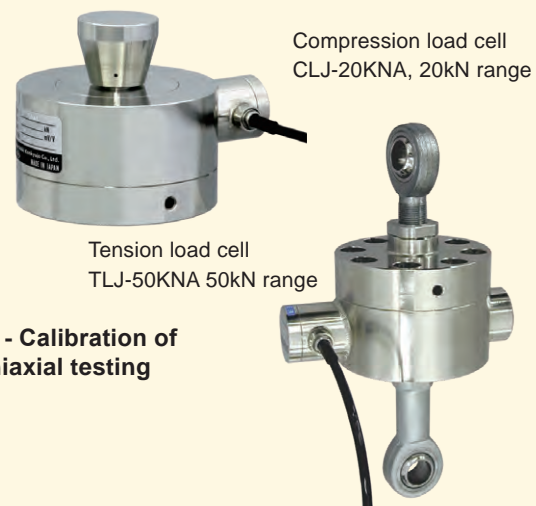

LOAD CELLS

Load Cell selection

Capacity Type	N								kN										MN					Page			
	2	5	10	20	50	100	200	500	1	2	5	10	20	30	50	100	200	300	500	1	1.5	2	3		5	10	
COMPRESSION TYPE																											
CLS-NA	●	●	●	●	●	●																					7
CLS-NB							●	●	●	●	●	●															7
CLA-NA							●	●	●	●	●	●															8
CLG-NB											●	●			●	●	●										9
CLP-NB											●	●	●	●	●	●	●	●	●	●	●	●	●	●	●	●	10
CLU-NA											●	●			●	●	●			●	●					11	
CLM-NB											●	●			●	●	●			●						12	
CLJ-NA										●	●	●	●													13	
CLJ-NB															●	●	●	●	●	●	●	●	●	●	●	●	14
CLF-NA																				●	●	●	●	●	●	●	15
CLF-NA																					●	●	●	●	●	●	15
CLR-NAH							●	●	●	●	●	●			●	●	●									16	
CLC-NA															●	●	●	●	●	●	●	●	●	●	●	●	17
KCM-NA											●	●			●	●	●	●	●	●	●	●	●	●	●	●	18
KCE-NA																				●	●	●	●	●	●	●	19
KCH-NA																				●	●	●	●	●	●	●	20
KCC-NA																					●	●					21
KCG-NA																					●	●					21
KCK-NA																					●	●					22
CLL-NA																				●	●						23
CLH-NA																				●	●	●					23
TENSION/COMPRESSION UNIVERSAL TYPE																											
TCLZ-NA			●	●	●	●	●	●	●	●	●	●															24
TCLB-NA				●	●	●																					25
TCLA-NB							●	●	●	●	●	●															25
TCLY-NA																		●	●	●	●	●	●	●	●	●	26
TCLN-NA							●	●	●	●																	26
TCLK-NA											●	●	●		●												27
TCLU-NA											●	●	●		●	●	●										28
TCLM-NB											●	●	●		●	●	●										29
TCLP-NB											●	●	●	●	●	●	●	●	●	●	●	●	●	●	●	●	30
TENSION TYPE																											
TLJ-NA											●	●			●	●											31
TLP-NB											●	●	●	●	●	●	●	●	●	●	●	●	●	●	●	●	32
3-Component Load Cell																											
SLP-NA-T						●	●	●	●																		33

Load Cell Fitting accessory

Fitting accessory	Applicable load cells	Accessory page
Spherical Cap FA	Compression Load Cell	CLA-NA, CLP-NB, CLG-NB, CLM-NB, CLU-NA, CLR-NAH
	Tension/Compression Universal Load Cell	TCLN-NA, TCLB-NA, TCLA-NB, TCLP-NB, TCLK-NA, TCLZ-NA, TCLU-NA, TCLM-NB
Mounting Flange FB	Compression Load Cell	CLA-NA, CLP-NB, CLG-NB, CLM-NB, CLU-NA, CLR-NAH
	Tension/Compression Universal Load Cell	TCLB-NA, TCLM-NB
Slide Support FC	Compression Load Cell	CLA-NA, CLP-NB, CLG-NB, CLM-NB, CLU-NA, CLR-NAH
Rotary Attachment FD	Tension/Compression Universal Load Cell	TCLB-NA, TCLZ-NA, TCLU-NA, TCLM-NB
Rod End FE	Tension/Compression Universal Load Cell	TCLN-NA, TCLB-NA, TCLA-NB, TCLA-NB, TCLP-NB, TCLK-NA, TCLZ-NA, TCLU-NA, TCLM-NB
	Tension Load Cell	TLJ-NA
Eye Bolt FF	Tension/Compression Universal Load Cell	TCLP-NB, TCLZ-NA, TCLU-NA, TCLM-NB
Load Button FG	Tension/Compression Universal Load Cell	TCLB-NA, TCLP-NB, TCLK-NA, TCLZ-NA, TCLU-NA, TCLM-NB
Sackle FH	Tension/Compression Universal Load Cell	TCLP-NB, TCLZ-NA, TCLU-NA, TCLM-NB
	Tension Load Cell	TLP-NB,

Torque transducer selection

Capacity Type	N-m							kN-m	Page
	10	20	30	50	100	200	300	500	
LTA-NA				●	●	●		●	34
LTB-NA	●	●	●	●	●	●	●	●	34

CLS-NA/CLS-NB Compression Load Cell

2N~10kN

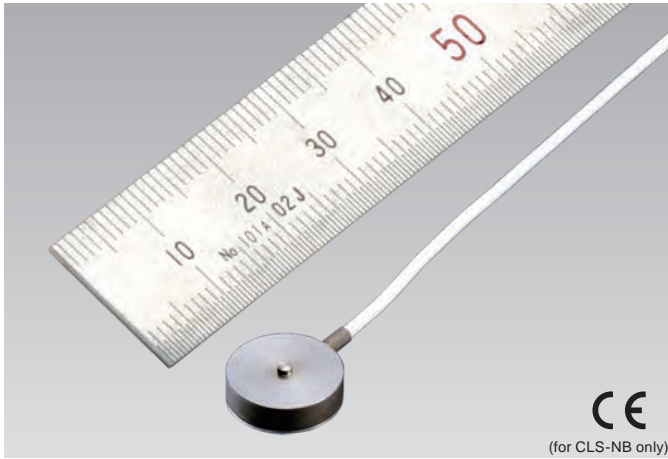

The CLS-NA and CLS-NB Load Cells are ultracompact load cells with capacities ranging from 2N to 10kN. They are widely used for measuring load distribution or loads in structural mockup testing and as a sensor for industrial machinery.

Protection ratings: IP41 equivalent CLS-2NA/CLS-5NA
IP53 equivalent Others

Ultracompact
Light weight

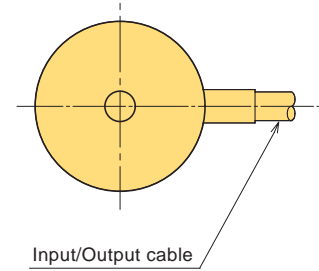

CLS-2NA~5KNB

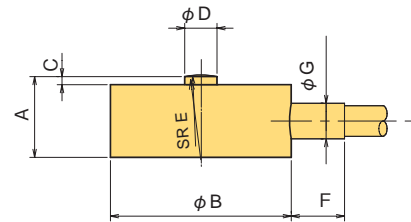

CLS-10KNB

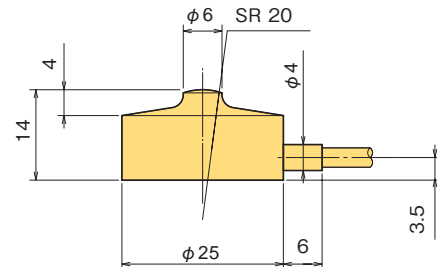

■ DIMENSIONS

TYPE	A	φB	C	φD	E	F	φG
CLS-2NA	4	12	0.7	1.5	2	4	1.8
CLS-5NA	4	12	0.7	1.5	2	4	1.8
CLS-10NA	4	12	0.7	1.5	2	4	1.8
CLS-20NA	4	12	0.7	1.5	2	4	1.8
CLS-50NA	4	12	0.7	1.5	2	4	1.8
CLS-100NA	4	12	0.7	1.5	2	4	1.8
CLS-200NB	9	20	1	2.5	8	6	4
CLS-500NB	9	20	1	2.5	8	6	4
CLS-1KNB	9	20	1	2.5	8	6	4
CLS-2KNB	10	20	1.5	3	8	6	4
CLS-5KNB	12.5	25	2	4	10	6	4
CLS-10KNB	As per the figure						

■ SPECIFICATIONS

TYPE	CLS-2NA	CLS-5NA	CLS-10NA	CLS-20NA	CLS-50NA	CLS-100NA	CLS-200NB	CLS-500NB	CLS-1KNB	CLS-2KNB	CLS-5KNB	CLS-10KNB
Capacity	2N	5N	10N	20N	50N	100N	200N	500N	1kN	2kN	5kN	10kN
Rated Output	1mV/V (2000×10 ⁻⁶ strain) ±20% *						1.5mV/V (3000×10 ⁻⁶ strain) ±10%					
Non-linearity	1%RO		0.5%RO									
Hysteresis	1%RO		0.5%RO									
Natural frequency	10kHz	20kHz	16kHz	30kHz	40kHz	50kHz	40kHz	50kHz	50kHz	60kHz	50kHz	40kHz
Temperature effect on zero	0.2%RO/°C		0.1%RO/°C									
Temperature effect on span	0.05%/°C											
Compensated temperature range	-10 ~ +60°C											
Allowable temperature range	-10 ~ +60°C											
Over load	150%											
Ultimate overload rating	300%		500%				300%					
Input/Output resistance	350Ω±2%						350Ω±1%					
Recommended exciting voltage	2V or less											
Allowable exciting voltage	5V											
Zero balance	200%RO		150%RO				100%RO					
Weight	1g	1g	3g	3g	3g	3g	12g	12g	12g	12g	40g	40g

Input/Output cable : CLS-NA φ 1.3mm 0.03mm² 4-core vinyl cable 2m

: CLS-NB φ 3mm 0.05mm² 4-core shielded chloroprene cable 2m

NB * : Tolerance of rated output for CLS-2NA and CLS-5NA is ±30%.

LOAD CELLS

CLA-NA Compression Load Cell 500N~20kN



The CLA-NA Load Cell has a diaphragm type strain sensing element. It is compact, easy to operate and can be used to take consistent measurement.

Protection ratings: IP67 equivalent

Small size
Hermetically sealed

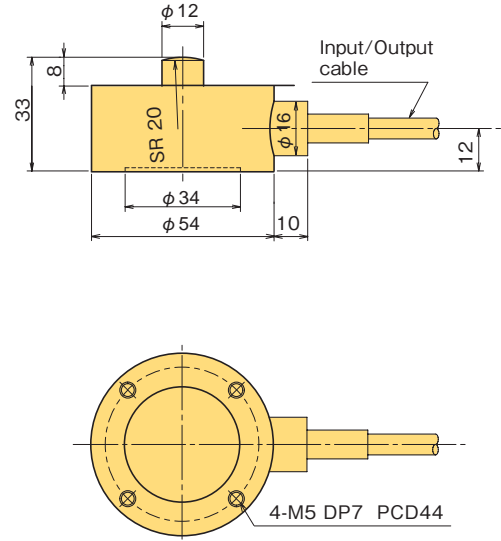

■ FITTING ACCESSORY

TYPE	Spherical Cap FA	Mounting Flange FB	Slide Support FC
CLA-500NA~ 20KNA	FA-20	FB-2-44	FC-2-20

Refer to pages 35~38 for load cell fitting accessories.

■ SPECIFICATIONS

TYPE	CLA-500NA	CLA-1KNA	CLA-2KNA	CLA-5KNA	CLA-10KNA	CLA-20KNA
Capacity	500N	1kN	2kN	5kN	10kN	20kN
Rated Output	1.5mV/V (3000×10 ⁻⁶ strain) ±0.5%					
Non-linearity	0.2%RO					
Hysteresis	0.1%RO					
Natural frequency	6.1kHz	8.9kHz	13kHz	19kHz	24kHz	28kHz
Temperature effect on zero	0.01%RO/°C					
Temperature effect on span	0.01%/°C					
Compensated temperature range	-10 ~ +60°C					
Allowable temperature range	-20 ~ +70°C					
Over load	150%					
Input/Output resistance	350Ω±2%					
Recommended exciting voltage	6V or less					
Allowable exciting voltage	15V					
Zero balance	5%RO					
Weight	0.36kg					0.38kg

Input/Output cable : φ6mm 0.35mm² 4-core shielded chloroprene cable 5m

CLG-NB Compression Load Cell 10~200kN



The CLG-NB is a high precision load cell in a thin, hermetically sealed package. It is widely used in tight spaces and as a system sensor for industrial machinery.

Protection ratings: IP67 equivalent

Low profile
Hermetically sealed

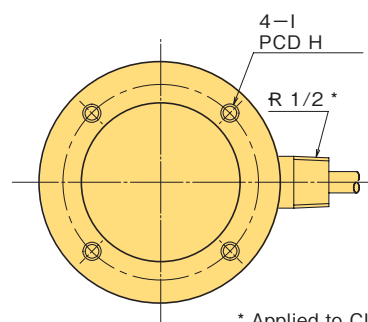
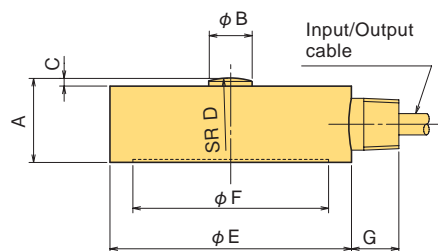

* Applied to CLG-50KNB ~ CLG-200KNB

■ DIMENSIONS

TYPE	A	φ B	C	D	φ E	φ F	G	H	I
CLG-10KNB	25	12	3	60	84	59	10	70	M5 DP8
CLG-20KNB	25	12	3	60	84	59	10	70	M5 DP8
CLG-50KNB	35	18	3	60	102	67	20	82	M8 DP10
CLG-100KNB	40	22	5	80	117	71	20	90	M8 DP10
CLG-200KNB	50	28	7	100	127	77	20	100	M8 DP10

■ FITTING ACCESSORY

TYPE	Spherical Cap FA	Mounting Flange FB	Slide Support FC
CLG-10KNB,-20KNB	FA-60	FB-2-70	FC-5-60
CLG-50KNB	FA-60	FB-5-82	FC-5-60
CLG-100KNB	FA-80	FB-10-90	FC-20-80
CLG-200KNB	FA-100	FB-20-100	FC-20-100

Refer to pages 35~38 for load cell fitting accessories.

■ SPECIFICATIONS

TYPE	CLG-10KNB	CLG-20KNB	CLG-50KNB	CLG-100KNB	CLG-200KNB
Capacity	10kN	20kN	50kN	100kN	200kN
Rated Output	2mV/V (4000×10 ⁻⁶ strain) ±0.5%				
Non-linearity	0.2%RO				
Hysteresis	0.2%RO				
Natural frequency	10kHz	13kHz	13kHz	13kHz	13kHz
Temperature effect on zero	0.01%RO/°C				
Temperature effect on span	0.005%/°C				
Compensated temperature range	-10 ~ +60°C				
Allowable temperature range	-20 ~ +70°C				
Over load	150%				
Input/Output resistance	350Ω±1%				
Recommended exciting voltage	6V or less				
Allowable exciting voltage	15V				
Zero balance	5%RO				
Weight	0.9kg	0.9kg	1.8kg	2.6kg	3.8kg

Input/Output cable : CLG-10KNB, 20KNB : φ6mm 0.35mm² 4-core shielded chloroprene cable 5m
: CLG-50KNB~ 200KNB : φ9mm 0.5mm² 4-core shielded chloroprene cable 5m

LOAD CELLS

CLP-NB Compression Load Cell 10kN~10MN



**General purpose
Various capacities**

The CLP-NB has a column type strain sensing element. With a full line of products with capacities ranging from 10kN to 10MN, customers can select a model for any load level.

NB: Available with built-in two isolated I/O ports at option

Protection ratings: IP65 equivalent

CLP-10~ 500KNB

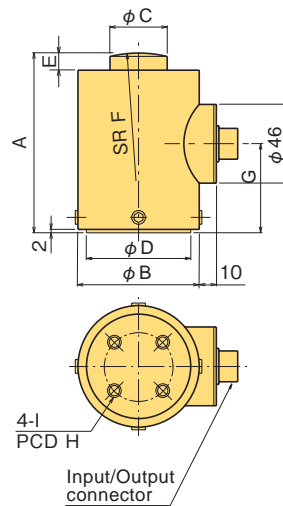

CLP-1~ 5MNB

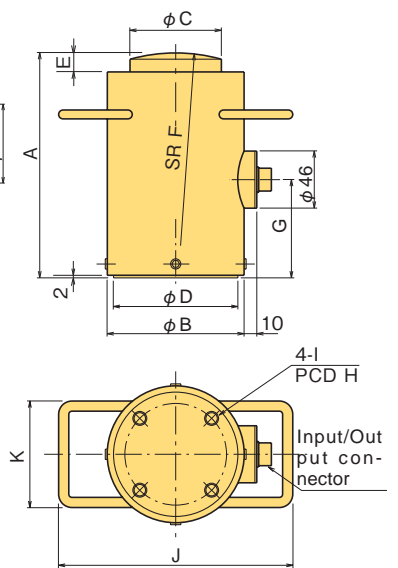

■ DIMENSIONS

TYPE	A	φ B	φ C	φ D	E	F	G	H	I	J	K
CLP-10KNB	80	60	22	50	8	60	40	30	M8DP10	-	-
CLP-20KNB	80	60	22	50	8	60	40	30	M8DP10	-	-
CLP-30KNB	80	60	22	50	8	60	40	30	M8DP10	-	-
CLP-50KNB	80	60	22	50	8	60	40	30	M8DP10	-	-
CLP-100KNB	80	60	24	50	8	80	40	30	M8DP10	-	-
CLP-200KNB	105	70	34	60	10	100	52	40	M8DP10	-	-
CLP-300KNB	145	90	50	80	15	140	72	60	M8DP15	-	-
CLP-500KNB	145	90	50	80	15	140	72	60	M8DP15	-	-
CLP-1MNB	180	110	74	100	15	160	80	80	M12DP15	186	86
CLP-2MNB	230	140	100	130	15	250	100	100	M16DP18	240	120
CLP-3MNB	275	160	120	150	15	360	135	120	M16DP18	260	120
CLP-5MNB	345	200	155	185	20	360	165	140	M20DP25	300	120
CLP-10MNB	As per the figure										

CLP-10MNB

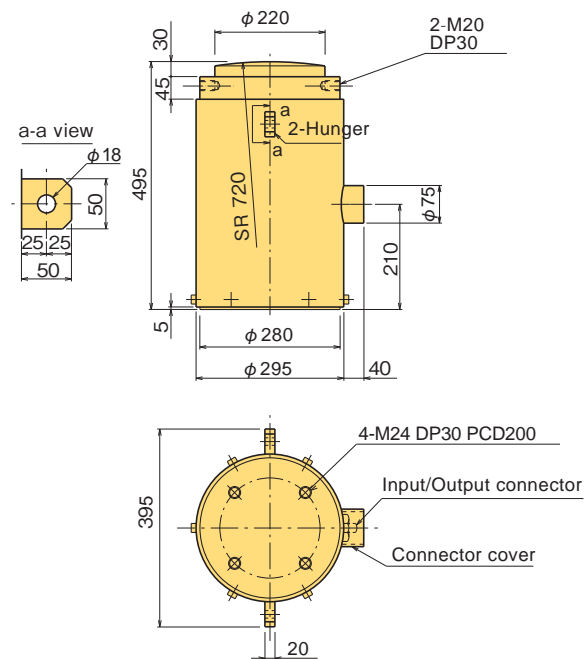

■ FITTING ACCESSORY

TYPE	Spherical Cap FA	Mounting Flange FB	Slide Support FC
CLP-10KNB~ 50KNB	FA-60	FB-10-30	FC-5-60
CLP-100KNB	FA-80	FB-10-30	FC-20-80
CLP-200KNB	FA-100	FB-20-40	FC-20-100
CLP-300KNB~500KNB	FA-140	FB-50-60	FC-50-140
CLP-1MNB	FA-160	FB-100-80	-
CLP-2MNB	FA-250	FB-200-100	-
CLP-3MNB	FA-360	FB-300-120	-
CLP-5MNB	FA-360B	FB-500-140	-
CLP-10MNB	FA-720	FB-1000-200	-

Refer to pages 35~38 for load cell fitting accessories.

■ SPECIFICATIONS

TYPE	CLP-10KNB	CLP-20KNB	CLP-30KNB	CLP-50KNB	CLP-100KNB	CLP-200KNB	CLP-300KNB	CLP-500KNB	CLP-1MNB	CLP-2MNB	CLP-3MNB	CLP-5MNB*	CLP-10MNB*
Capacity	10kN	20kN	30kN	50kN	100kN	200kN	300kN	500kN	1MN	2MN	3MN	5MN	10MN
Rated Output	1.5mV/V (3000×10 ⁻⁶ strain) ±0.2%												
Non-linearity	0.1%RO											0.2%RO	
Hysteresis	0.1%RO												
Natural frequency	7.5kHz	9.2kHz	11kHz	14kHz	19kHz	16kHz	11kHz	13kHz	13kHz	7.0kHz	5.8kHz	4.5kHz	2.7kHz
Temperature effect on zero	0.01%RO/°C												
Temperature effect on span	0.005%/°C												
Compensated temperature range	-10 ~ +60°C												
Allowable temperature range	-20 ~ +70°C												
Over load	150%												
Input/Output resistance	350Ω±1%												
Recommended exciting voltage	10V or less												
Allowable exciting voltage	20V												
Zero balance	5%RO												
Weight	1.1kg	1.1kg	1.1kg	1.1kg	1.2kg	2.0kg	4.2kg	4.6kg	10kg	24kg	33kg	70kg	190kg

Input/Output cable : CT9-4N10/WP-STB (φ9mm 0.5mm² 4-core shielded chloroprene cable 10m) *Made-to-order

CLU-NA Compression Load Cell 10kN~1MN



The CLU-NA is an inert-gas encased load cell in a hermetically sealed package. It can take highly precise and consistent measurements over long periods of time.

NB: Available with built-in two isolated I/O ports at option

Protection ratings: IP65 equivalent

Inert gas hermetically sealed

CLU-10~500KNA

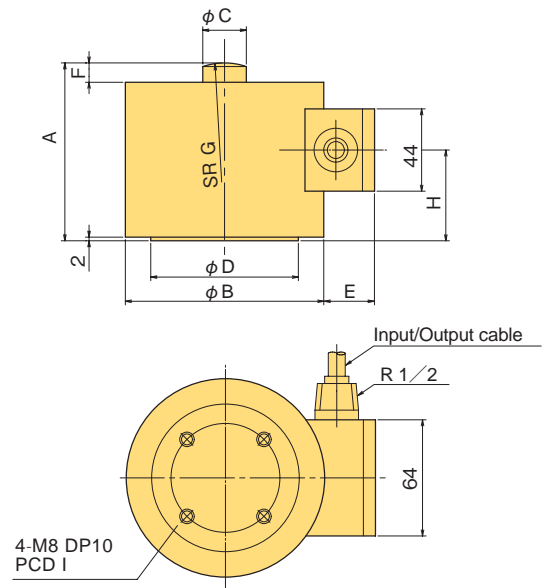

CLU-1MNA

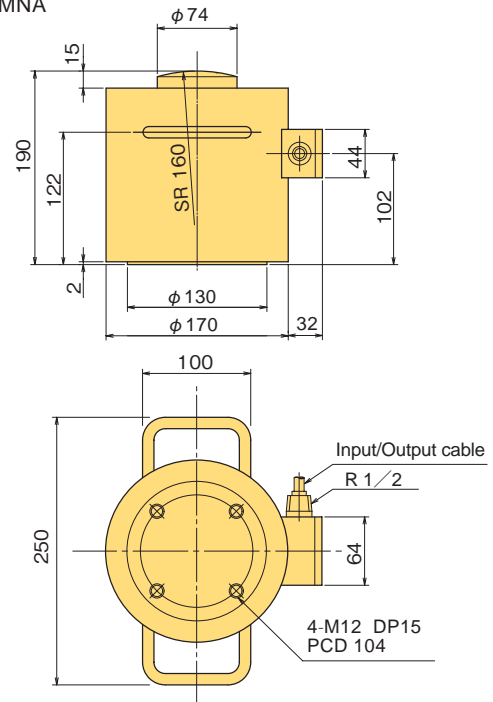

■ DIMENSIONS

TYPE	A	φB	φC	φD	E	F	G	H	I
CLU-10KNA	84	92	22	68	28	10	60	42	54
CLU-20KNA	84	92	22	68	28	10	60	42	54
CLU-50KNA	84	92	22	68	28	10	60	42	54
CLU-100KNA	96	108	24	80	28	10	80	49	60
CLU-200KNA	114	118	34	90	29	12	100	57	70
CLU-500KNA	158	160	50	120	31	15	140	82	100
CLU-1MNA	As per the figure								

■ FITTING ACCESSORY

TYPE	Spherical Cap FA	Mounting Flange FB	Slide Support FC
CLU-10KNA~ 50KNA	FA-60	FB-5-54	FC-5-60
CLU-100KNA	FA-80	FB-10-60	FC-20-80
CLU-200KNA	FA-100	FB-20-70	FC-20-100
CLU-500KNA	FA-140	FB-50-100	FC-50-140
CLU-1MNB	FA-160	FB-100-104	-

Refer to pages 35~38 for load cell fitting accessories.

■ SPECIFICATIONS

TYPE	CLU-10KNA	CLU-20KNA	CLU-50KNA	CLU-100KNA	CLU-200KNA	CLU-500KNA	CLU-1MNA
Capacity	10kN	20kN	50kN	100kN	200kN	500kN	1MN
Rated Output	2mV/V (4000×10 ⁻⁶ strain) ±0.2%						
Non-linearity	0.15%RO						
Hysteresis	0.05%RO						
Natural frequency	5.2kHz	9.5kHz	12kHz	13kHz	11kHz	9kHz	7kHz
Temperature effect on zero	0.005%/°C						
Temperature effect on span	0.005%/°C						
Compensated temperature range	-10 ~ +60°C						
Allowable temperature range	-30 ~ +80°C						
Over load	150%						
Input/Output resistance	350Ω±1%						
Recommended exciting voltage	10V or less						
Allowable exciting voltage	20V						
Zero balance	5%RO						
Weight	2.2kg	2.2kg	2.2kg	3.2kg	4.3kg	11kg	15kg

Input/Output cable : φ9mm 0.5mm² 4-core shielded chloroprene cable 5m

LOAD CELLS

CLM-NB Compression Load Cell 10kN~500kN



The CLM-NB is an inert-gas encased load cell in a hermetically sealed package. It offers high precision, high output characteristics and excellent consistency because it uses a shear beam for the strain sensing element. This model is widely used in applications like test equipment.

Protection ratings: IP65 equivalent

High precision
Inert gas hermetically sealed

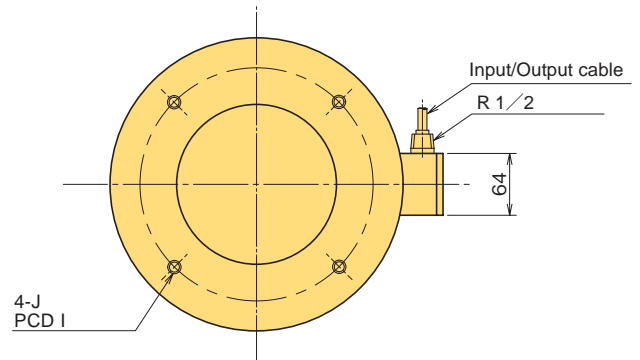
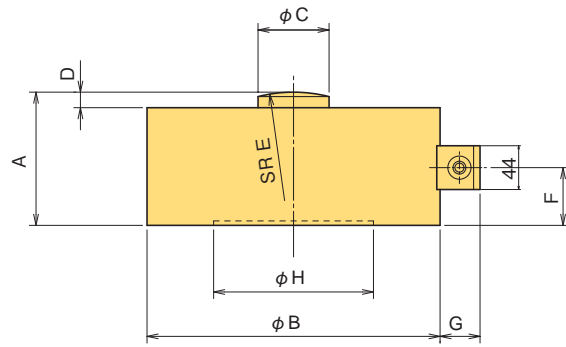

■ DIMENSIONS

TYPE	A	φB	φC	D	E	F	G	φH	I	J
CLM-10KNB	60	98	22	5	60	27.5	31	64	80	M8 DP10
CLM-20KNB	60	98	22	5	60	27.5	31	64	80	M8 DP10
CLM-50KNB	60	98	22	5	60	27.5	31	64	80	M8 DP10
CLM-100KNB	70	118	24	5	80	32.5	34	68	90	M8 DP10
CLM-200KNB	90	157	34	10	100	40	37	86	120	M8 DP15
CLM-500KNB	110	187	50	10	140	50	38	110	150	M8 DP15

■ FITTING ACCESSORY

TYPE	Spherical Cap FA	Mounting Flange FB	Slide Support FC
CLM-10KNB~50KNB	FA-60	FB-5-80	FC-5-60
CLM-100KNB	FA-80	FB-10-90	FC-20-80
CLM-200KNB	FA-100	FB-20-120	FC-20-100
CLM-500KNB	FA-140	FB-50-150	FC-50-140

Refer to pages 35~38 for load cell fitting accessories.

■ SPECIFICATIONS

TYPE	CLM-10KNB	CLM-20KNB	CLM-50KNB	CLM-100KNB	CLM-200KNB	CLM-500KNB
Capacity	10kN	20kN	50kN	100kN	200kN	500kN
Rated Output	2.5mV/V (5000×10 ⁻⁶ strain) ±0.2%					
Non-linearity	0.03%RO					
Hysteresis	0.03%RO					
Natural frequency	5.3kHz	7.1kHz	10kHz	12kHz	7.5kHz	7.5kHz
Temperature effect on zero	0.002%RO/°C					
Temperature effect on span	0.002%/°C					
Compensated temperature range	-10 ~ +60°C					
Allowable temperature range	-30 ~ +80°C					
Over load	150%					
Input/Output resistance	350Ω±1%					
Recommended exciting voltage	10V or less					
Allowable exciting voltage	20V					
Zero balance	5%RO					
Weight	2.5kg	2.5kg	3kg	5kg	11kg	18kg

Input/Output cable : φ9mm 0.5mm² 4-core shielded chloroprene cable 5m

CLJ-NA Compression Load Cell

5~30kN

Made-to-order



The CLJ-NA is designed considering JIS B 7728 "Calibration of force-proving instruments used for the verification of uniaxial testing machine" and is the most suitable for verification of single axis compression testing machine. Calibration in accordance with JIS B 7728 is available at extra cost.

Protection ratings: IP65 equivalent

High stability

Remote sensing compatible

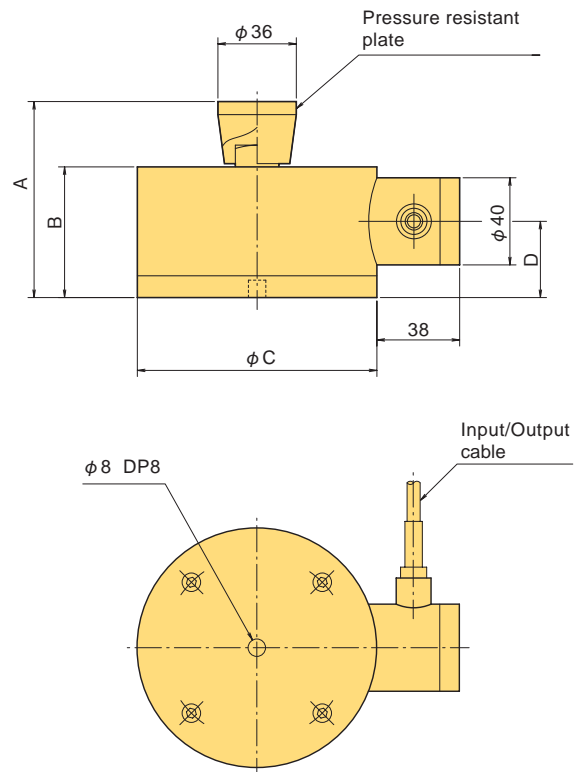

■ DIMENSIONS

TYPE	A	B	φC	D
CLJ-5KNA	90	60	110	35
CLJ-10KNA	90	60	110	35
CLJ-20KNA	90	60	110	35
CLJ-30KNA	95	65	125	40

■ SPECIFICATIONS

TYPE	CLJ-5KNA	CLJ-10KNA	CLJ-20KNA	CLJ-30KNA
Capacity	5kN	10kN	20kN	30kN
Rated Output	2mV/V (4000×10 ⁻⁶ strain) or more			
Non-linearity	0.05%RO			
Hysteresis	0.05%RO			
Natural frequency	5.6kHz	6.9kHz	8.5kHz	7.7kHz
Temperature effect on zero	0.005%RO/°C			
Temperature effect on span	0.005%/°C			
Compensated temperature range	-10 ~ +60°C			
Allowable temperature range	-30 ~ +80°C			
Over load	150%			
Ultimate overload rating	300%			
Input/Output resistance	350Ω±2%			
Recommended exciting voltage	6V or less			
Allowable exciting voltage	15V			
Zero balance	5%RO			
Weight	4kg	4kg	4kg	6kg

Input/Output cable : φ6mm 0.08mm² 6-core shielded polyurethane cable 5m (Remote-sensing compatible)

LOAD CELLS

CLJ-NB Compression Load Cell

50kN~10MN



The CLJ-NB is designed considering JIS B 7728 "Calibration of force-proving instruments used for the verification of uniaxial testing machine" and is the most suitable for verification of single axis compression testing machine. Calibration in accordance with JIS B 7728 is available at extra cost.

Protection ratings: IP67 equivalent

High stability

Remote sensing compatible

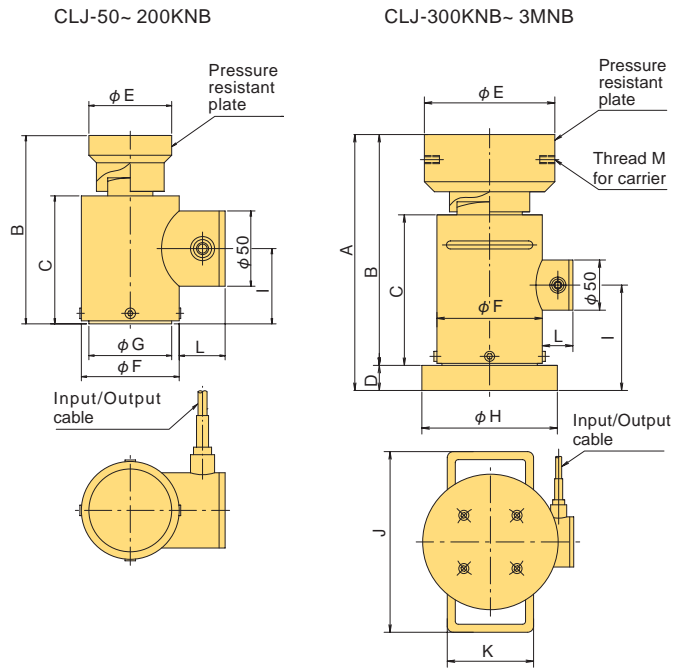

CLJ-5MNB, -10MNB

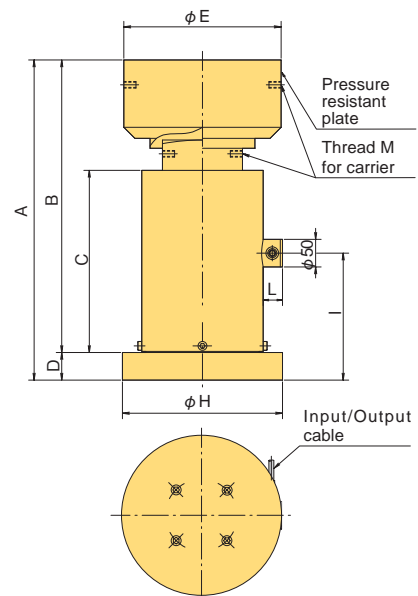

■ DIMENSIONS

TYPE	A	B	C	D	φE	φF	φG	φH	I	J	K	L	M
CLJ-50KNB	-	110	73	-	40	60	50	-	41	-	-	31	-
CLJ-100KNB	-	110	73	-	40	60	50	-	41	-	-	31	-
CLJ-200KNB	-	125	85	-	55	65	55	-	50	-	-	31	-
CLJ-300KNB	175	160	105	15	80	75	-	80	75	-	-	31	-
CLJ-500KNB	195	180	120	15	90	85	-	95	80	-	-	31	-
CLJ-1MNB	255	230	150	25	130	105	-	135	105	180	86	35	2-M8 DP15
CLJ-2MNB	340	305	200	35	180	130	-	185	145	230	120	35	2-M10 DP18
CLJ-3MNB	420	370	240	50	225	155	-	225	190	255	120	35	2-M12 DP22
CLJ-5MNB	580	530	330	50	285	220	-	290	230	-	-	35	4-M12 DP22
CLJ-10MNB	790	710	425	80	410	270	-	410	325	-	-	35	4-M20 DP30

■ SPECIFICATIONS

TYPE	CLJ-50KNB	CLJ-100KNB	CLJ-200KNB	CLJ-300KNB	CLJ-500KNB	CLJ-1MNB	CLJ-2MNB	CLJ-3MNB*	CLJ-5MNB*	CLJ-10MNB*
Capacity	50kN	100kN	200kN	300kN	500kN	1MN	2MN	3MN	5MN	10MN
Rated Output	2mV/V (4000×10 ⁻⁶ strain) or more									
Non-linearity	0.05%RO									
Hysteresis	0.05%RO									
Natural frequency	6.1kHz	8.5kHz	8.1kHz	5.5kHz	5.4kHz	4.1kHz	3.0kHz	2.4kHz	1.7kHz	1.3kHz
Temperature effect on zero	0.0005%/°C									
Temperature effect on span	0.0005%/°C									
Compensated temperature range	-10 ~ +60°C									
Allowable temperature range	-20 ~ +70°C									
Over load	150%									
Ultimate overload rating	300%									
Input/Output resistance	350Ω±2%									
Recommended exciting voltage	10V or less									
Allowable exciting voltage	20V									
Zero balance	5%RO									
Weight	2kg	2kg	2.5kg	5kg	7kg	20kg	45kg	85kg	175kg	470kg

Input/Output cable : CLJ-50KNB~ -500KNB φ 6mm 0.08mm² 6-core shielded polyurethane cable 5m (Remote-sensing compatible)
 : CLJ-1MNB~ -10MNB φ 9mm 0.3mm² 6-core shielded vinyl cable 5m (Remote-sensing compatible)

*Made-to-order

CLF-NA Compression Load Cell 500kN~2MN



Low profile
Flat surface

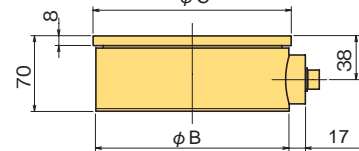
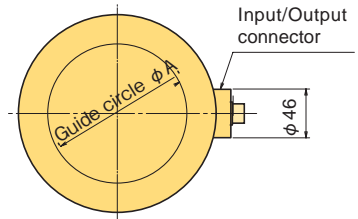

The CLF-NA is a thin load cell with a flat load bearing surface. It is widely used as a load sensor for industrial machinery, especially when measuring loads on rolling machines or measuring compression force on presses.

Protection ratings: IP65 equivalent

■ SPECIFICATIONS

TYPE	CLF-500KNA	CLF-1MNA	CLF-1.5MNA	CLF-2MNA
Capacity	500kN	1MN	1.5MN	2MN
Rated Output	2mV/V (4000×10 ⁻⁶ strain) ±0.5%			
Non-linearity	0.3%RO			
Hysteresis	0.2%RO			
Temperature effect on zero	0.01%RO/°C			
Temperature effect on span	0.005%/°C			
Compensated temperature range	-10 ~ +60°C			
Allowable temperature range	-20 ~ +70°C			
Over load	150%			
Input/Output resistance	350Ω±5%			
Recommended exciting voltage	10V or less			
Allowable exciting voltage	20V			
Zero balance	5%RO			
Weight	6kg	8kg	10kg	13kg

Supplied cable : CT9-4N10/WP-STB (φ9mm 0.5mm² 4-core shielded chloroprene cable 10m)

N.B.: Force should be applied uniformly to the surface including guide circle.

■ DIMENSIONS

TYPE	φ A	φ B	φ C
CLF-500KNA	95	140	145
CLF-1MNA	130	180	185
CLF-1.5MNA	150	200	205
CLF-2MNA	170	220	225

CLF-NA Compression Load Cell 3~10MN

Made-to-order



Low profile
Flat surface

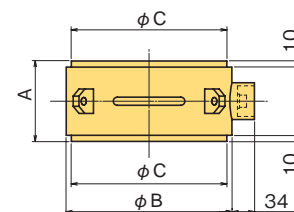
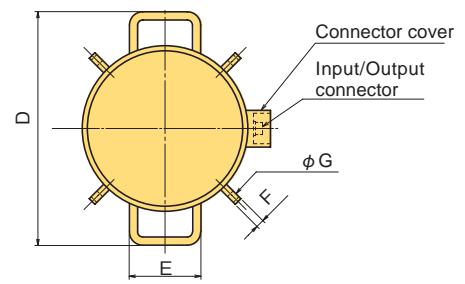

The CLF-NA is a thin load cell with a flat load bearing surface. It is widely used as a load sensor for industrial machinery, especially when measuring loads on rolling machines or measuring compression force on presses.

Protection ratings: IP65 equivalent

■ SPECIFICATIONS

TYPE	CLF-3MNA	CLF-5MNA	CLF-10MNA
Capacity	3MN	5MN	10MN
Rated Output	1.5mV/V (3000×10 ⁻⁶ strain) ±0.5%		
Non-linearity	0.3%RO		
Hysteresis	0.2%RO		
Temperature effect on zero	0.01%RO/°C		
Temperature effect on span	0.005%/°C		
Compensated temperature range	-10 ~ +60°C		
Allowable temperature range	-20 ~ +70°C		
Over load	150%		
Input/Output resistance	350Ω±5%		
Recommended exciting voltage	10V or less		
Allowable exciting voltage	20V		
Zero balance	5%RO		
Weight	40kg	66kg	150kg

Supplied cable : CT9-4N10/WP-STB (φ9mm 0.5mm² 4-core shielded chloroprene cable 10m)

N.B.: Force should be applied uniformly to the sur-face.

■ DIMENSIONS

TYPE	A	φ B	φ C	D	E	F	φ G
CLF-3MNA	125	255	240	355	110	13	11
CLF-5MNA	135	320	300	430	120	16	13
CLF-10MNA	170	415	390	555	130	27	22

LOAD CELLS

CLR-NAH Compression Load Cell 500N~200kN

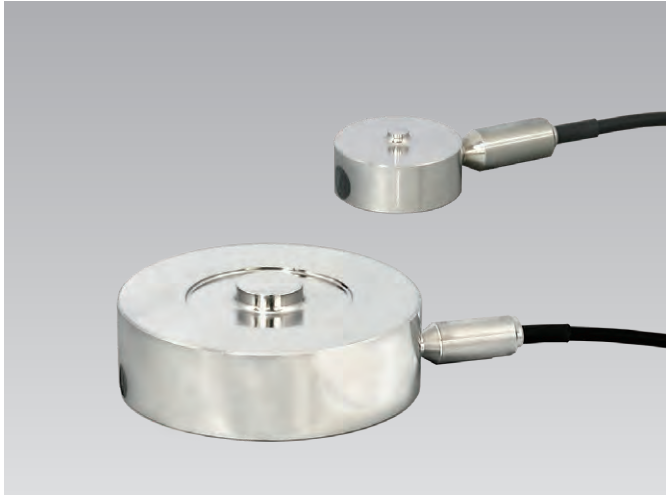

CLR-500NAH~ 20KNAH

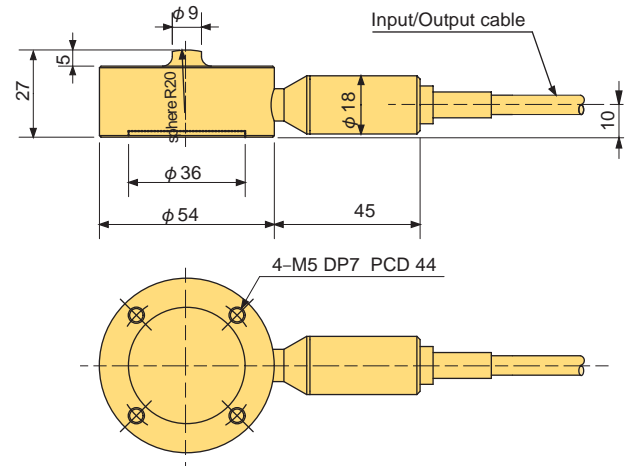

The CLR-NAH compression load cell can be used at high temperatures. The inert gas-filled and hermetically sealed structure offers stable measurement.

Protection ratings: IP67 equivalent

High temperature upto 160°C
Inert gas hermetically sealed

CLR-50~ 200KNAH

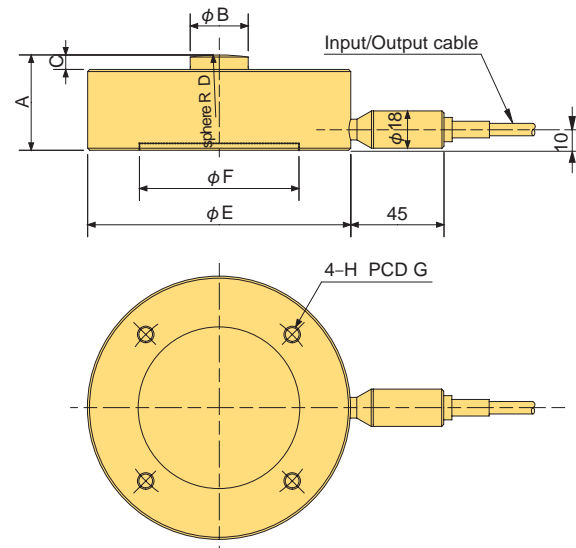

■ FITTING ACCESSORY

TYPE	Spherical Cap FA	Mounting Flange FB	Slide Support FC
CLR-500NAH CLR-1KNAH~ 20KNAH	FA-20	FB-2-44	FC-2-20
CLR-50KNAH	FA-60	FB-5-82	FC-5-60
CLR-100KNAH	FA-80	FB-10-90	FC-20-80
CLR-200KNAH	FA-100	FB-20-100	FC-20-100

Refer to pages 35~38 for load cell fitting accessories.

■ DIMENSIONS

TYPE	A	φB	C	D	φE	φF	G	H
CLR-50KNAH	31	18	3	60	102	67	82	M8 DP10
CLR-100KNAH	36	22	5	80	117	71	90	M8 DP10
CLR-200KNAH	46	28	7	100	127	77	100	M8 DP10

■ SPECIFICATIONS

TYPE	CLR-500NAH	CLR-1KNAH	CLR-2KNAH	CLR-5KNAH	CLR-10KNAH	CLR-20KNAH	CLR-50KNAH	CLR-100KNAH	CLR-200KNAH
Capacity	500N	1kN	2kN	5kN	10kN	20kN	50kN	100kN	200kN
Rated Output	2mV/V (4000×10 ⁻⁶ strain) ±25%								
Non-linearity	0.5%RO								
Hysteresis	0.5%RO								
Natural frequency	6.1kHz	8.9kHz	13kHz	19kHz	24kHz	28kHz	13kHz	13kHz	13kHz
Temperature effect on zero	0.005%RO/°C								
Temperature effect on span	0.01%/°C								
Compensated temperature range	-10 ~ +160°C								
Allowable temperature range	-10 ~ +160°C								
Over load	150%								
Input/Output resistance	350Ω±2%								
Recommended exciting voltage	10V or less								
Allowable exciting voltage	20V								
Zero balance	±5000×10 ⁻⁶ strain or less								
Weight	0.3kg						1.4kg	2.2kg	3.6kg

Input/Output cable : φ6mm 0.3mm² 4-core shielded fluorocarbon resin cable 5m

CLC-NA Center-hole type Compression Load Cell 50kN~5MN



The CLC-NA is a center-hole-type load cell with a strain gauge mounted on a cylindrical strain sensing element. It is used to conduct pullout tests on anchors or laboratory experiments.

Protection ratings: IP65 equivalent

High precision

CLC-50KNA~ 3MNA

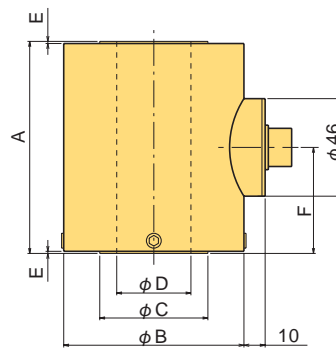

CLC-5MNA

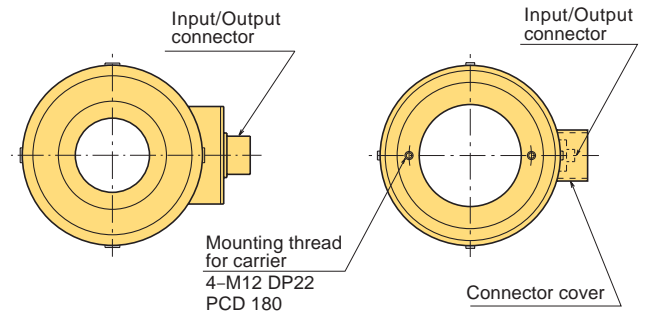
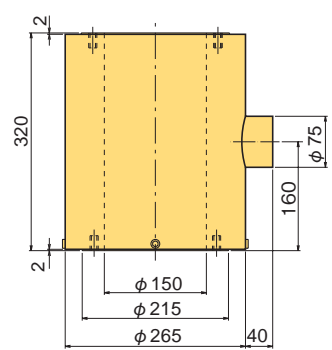

■ DIMENSIONS

TYPE	A	φB	φC	φD	E	F
CLC-50KNA	60	50	21	15	1	30
CLC-100KNA	70	60	29	20	1	35
CLC-200KNA	90	70	42	30	1	45
CLC-300KNA	100	85	51	35	1	50
CLC-500KNA	100	100	62	40	1	50
CLC-1MNA	150	130	90	60	2	75
CLC-2MNA	200	170	132	90	2	100
CLC-3MNA	250	205	164	115	2	125
CLC-5MNA	As per the figure					

■ SPECIFICATIONS

TYPE	CLC-50KNA	CLC-100KNA	CLC-200KNA	CLC-300KNA	CLC-500KNA	CLC-1MNA	CLC-2MNA	CLC-3MNA	CLC-5MNA*
Capacity	50kN	100kN	200kN	300kN	500kN	1MN	2MN	3MN	5MN
Rated Output	1.5mV/V (3000x10 ⁻⁶ strain) ±0.5%								
Non-linearity	0.3%RO					0.5%RO			
Hysteresis	0.3%RO					0.5%RO			
Natural frequency	20kHz	20kHz	17kHz	15kHz	15kHz	10kHz	7.7kHz	6.2kHz	4.7kHz
Temperature effect on zero	0.01%RO/°C								
Temperature effect on span	0.005%/°C								
Compensated temperature range	-10 ~ +60°C								
Allowable temperature range	-20 ~ +70°C								
Over load	150%								
Input/Output resistance	350Ω±1%								
Recommended exciting voltage	10V or less								
Allowable exciting voltage	20V								
Zero balance	5%RO								
Weight	1kg	2kg	2kg	3kg	4kg	8kg	19kg	34kg	67kg

Input/Output cable : CT9-4N10/WP-STB Waterproof plug (φ9mm 0.5mm² 4-core shielded chloroprene cable 10m) *Made-to-order

Pullout testing and axial force measurement

KCM-NA Center-hole type Compression Load Cell

Civil engineering design



The KCM-NA is a center-hole-type load cell with a strain gauge mounted on a cylindrical strain sensing element. It is used to measure prestress or tension force on ground anchors, pullout testing and measuring axial force on tie rods. The model is especially well suited for measuring on site.

Protection ratings: IP67 equivalent

Small type
Easy handling

KCM-10KNA~ 1MNA

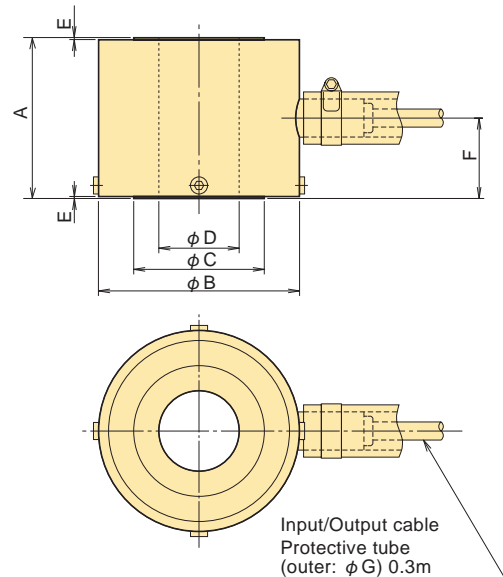

KCM-2MNA~ 5MNA

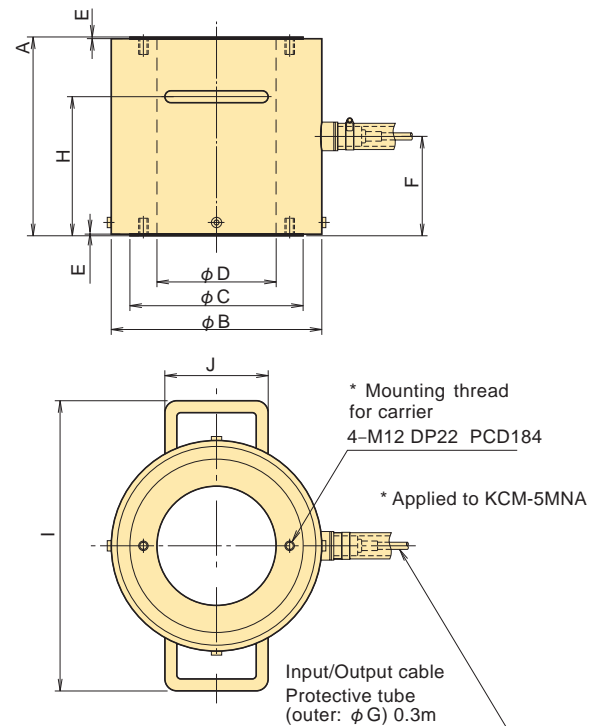

■ DIMENSIONS

TYPE	A	φB	φC	φD	E	F	φG	H	I	J
KCM-10KNA	50	50	18	15	1	29	26	-	-	-
KCM-20KNA	50	50	18	15	1	29	26	-	-	-
KCM-50KNA	50	50	22	15	1	29	26	-	-	-
KCM-100KNA	60	60	30	20	1	33	26	-	-	-
KCM-200KNA	70	70	44	30	1	35	26	-	-	-
KCM-300KNA	80	85	53	35	1	40	26	-	-	-
KCM-500KNA	80	100	65	40	1	40	26	-	-	-
KCM-1MNA	120	130	94	60	2	60	33	-	-	-
KCM-2MNA	160	170	135	90	2	80	33	110	234	124
KCM-3MNA	195	205	169	115	2	97.5	33	130	285	124
KCM-5MNA	250	265	218	150	2	125	33	175	365	130

■ SPECIFICATIONS

TYPE	KCM-10KNA	KCM-20KNA	KCM-50KNA	KCM-100KNA	KCM-200KNA	KCM-300KNA	KCM-500KNA	KCM-1MNA	KCM-2MNA*	KCM-3MNA*	KCM-5MNA*
Capacity	10kN	20kN	50kN	100kN	200kN	300kN	500kN	1MN	2MN	3MN	5MN
Rated Output	1.5mV/V (3000×10 ⁻⁶ strain) ±20%			1.5mV/V (3000×10 ⁻⁶ strain) ±10%							
Non-linearity	0.5%RO								1%RO		
Hysteresis	0.5%RO								1%RO		
Temperature effect on zero						0.1%RO/°C					
Temperature effect on span						0.05%/°C					
Compensated temperature range						-10 ~ +60°C					
Allowable temperature range						-20 ~ +70°C					
Over load	150%										
Input/Output resistance	350Ω±1%										
Recommended exciting voltage	10V or less										
Allowable exciting voltage	20V										
Zero balance	5%RO										
Weight	0.5kg	0.5kg	0.8kg	1.1kg	1.4kg	2kg	2.8kg	6.2kg	16kg	29kg	55kg

Input/Output cable : φ9mm 0.5mm² 4-core shielded chloroprene cable 5m *Made-to-order

KCE-NA Center-hole type Compression Load Cell

Civil engineering design



The KCE-NA is a center-hole-type load cell designed to use in tension measurement of anchoring strand. It can deliver stable measurement performance under somewhat eccentric load. An extra model with built-in temperature sensor is available.

Protection ratings: IP67 equivalent

Small effect of eccentric load

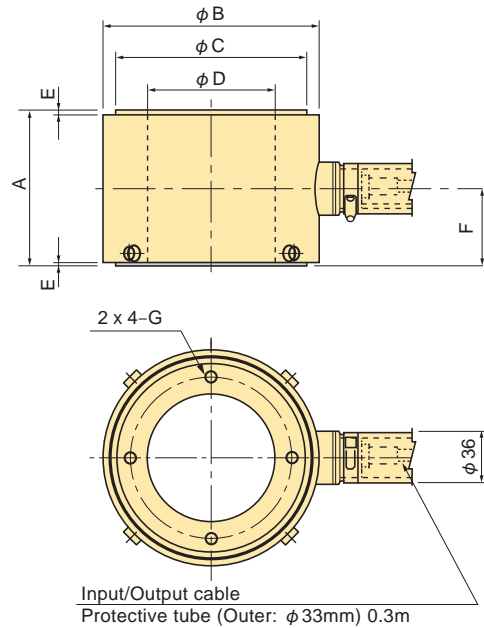

■ DIMENSIONS

TYPE	A	φ B	φ C	φ D	E	F	G
KCE-500KNA	77.5	130	113	82	2	39	M8 DP10 PCD 98
KCE-1MNA	109	150	134	90	2	54.5	M10DP12 PCD112
KCE-1.5MNA	115	185	160	110	4	57.5	M12DP15 PCD136
KCE-2MNA	155	215	188	140	5	77.5	M12DP15 PCD164

■ SPECIFICATIONS

TYPE	KCE-500KNA	KCE-1MNA	KCE-1.5MNA	KCE-2MNA
Capacity	500kN	1MN	1.5MN	2MN
Rated Output	1.25mV/V (2500×10 ⁻⁶ strain) ±10%			
Non-linearity	0.5%RO			
Hysteresis	0.5%RO			
Natural frequency	16kHz	12kHz	12kHz	9.2kHz
Temperature effect on zero	0.1%RO/°C			
Temperature effect on span	0.05%/°C			
Compensated temperature range	-10 ~ +60°C			
Allowable temperature range	-20 ~ +70°C			
Over load	120%			
Input/Output resistance	350Ω±1%			
Recommended exciting voltage	10V or less			
Allowable exciting voltage	20V			
Zero balance	5%RO			
Weight	4.0kg	8.5kg	12.2kg	21kg

Input/Output cable : φ 9mm 0.5mm² 4-core shielded chloroprene cable 5m

■ ACCESSORY

● FLANGE KCEF-11

This flange is a pressure plate used to secure a load cell to a structure.

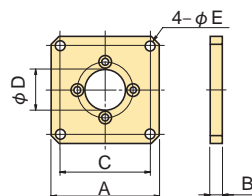
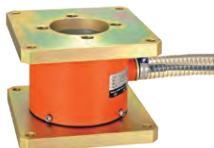

■ Dimensions

Type	Applicable Load Cell	A	B	C	φ D	φ E	Weight
KCEF-11-50	KCE-500KNA	180	20	150	82	12.5	4.1kg
KCEF-11-100	KCE-1MNA	200	20	170	90	12.5	5.1kg
KCEF-11-150	KCE-1.5MNA	220	35	190	110	12.5	10.4kg
KCEF-11-200	KCE-2MNA	250	35	220	140	12.5	13 kg

● FLANGE KCEF-12

This flange is a pressure plate used to consistently measure eccentric loads although with limitations.

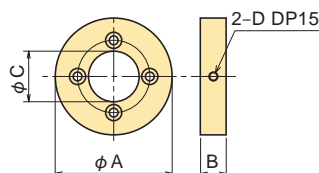

■ Dimensions

Type	Applicable Load Cell	φ A	B	φ C	D	Weight
KCEF-12-50	KCE-500KNA	156	26	82	M 8	2.8kg
KCEF-12-100	KCE-1MNA	176	35	90	M10	4.9kg
KCEF-12-150	KCE-1.5MNA	206	43	110	M10	7.9kg
KCEF-12-200	KCE-2MNA	236	47	140	M12	10 kg

Strand tension measurement

KCH-NA Center-hole type Compression Load Cell



Civil engineering design

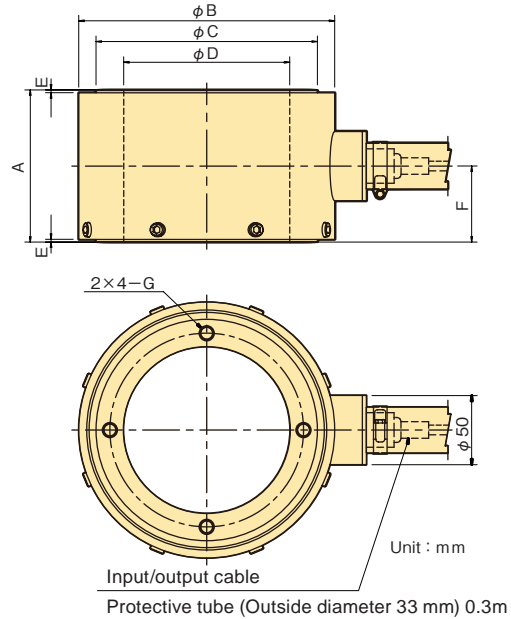
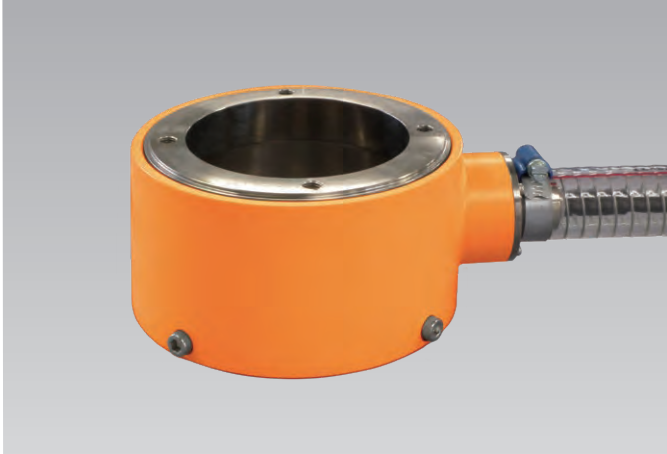

The KCH-NA is a center-hole type load cell used for the management of tensile force acting on a rod or strand in various anchor methods. The diameter of its center-hole is larger than that of our conventional type KCE-NA.

Protection ratings: IP68 equivalent

Large center-hole
Waterproof construction
(IP68 equivalent)
Small effect of eccentric load

■ DIMENSIONS

TYPE	A	φB	φC	φD	E	F	G
KCH-500KNA	80	140	125	95	2	40	M 8 DP10 PCD110
KCH-1MNA	110	185	160	120	2	55	M10DP12 PCD140
KCH-1.5MNA	135	210	185	145	4	67.5	M12DP15 PCD165
KCH-2MNA	Made-to-order manufacturing						

■ SPECIFICATIONS

Type	KCH-500KNA	KCH-1MNA	KCH-1.5MNA	KCH-2MNA
Capacity	500kN	1MN	1.5MN	2MN
Rated output	1.25mV/V (2500×10 ⁻⁶ strain) ±10%			
Non-linearity	0.5%RO			
Hysteresis	0.5%RO			
Natural frequency	16kHz	12kHz	11kHz	Made-to-order manufacturing
Temperature effect on zero	0.1%RO/°C			
Temperature effect on span	0.05%/°C			
Compensated temperature range	-10~+60°C			
Allowable temperature range	-20~+70°C			
Overload	120%			
Ultimate overload rating	200%			
Input/output resistance	350Ω			
Recommended exciting voltage	10V or less			
Allowable exciting voltage	20V			
Zero balance	5%RO			

Input/Output cable : Φ9mm 0.5mm² 4-core shielded Chloroprene cable 5m

*Output polarity (note) : The output polarity of this load cell changes to positive polarity as the compression force increases.

In addition to the above, custom-made products will also be available. Please contact us for the details.

■ ACCESSORY

● FLANGE KCHF-11

This flange is a pressure plate used to secure a load cell to a structure.

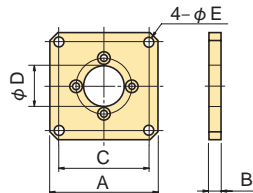
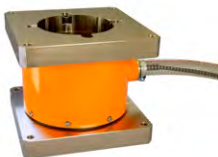

■ Dimensions

Type	Applicable Load Cell	A	B	C	φD	φE	Weight
KCEF-11-50	KCH-500KA	190	20	160	95	12.5	4.4kg
KCEF-11-100	KCH-1MNA	235	20	205	120	12.5	6.7kg
KCEF-11-150	KCH-1.5MNA	245	35	215	145	12.5	11.4kg
KCEF-11-200	KCH-2MNA	Made-to-order manufacturing					Please contact us for the details.

● FLANGE KCHF-12

This flange is a pressure plate used to consistently measure eccentric loads although with limitations.

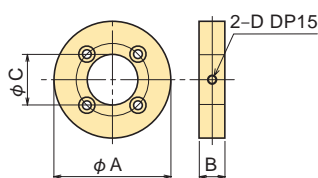

■ Dimensions

Type	Applicable Load Cell	φA	B	φC	D	Weight	
KCHF-12-50	KCH-500KA	160	30	95	M10	2.9	
KCHF-12-100	KCH-1MNA	200	40	120	M10	6.0	
KCHF-12-150	KCH-1.5MNA	230	47	145	M12	8.8	
KCHF-12-200	KCH-2MNA	Made-to-order manufacturing					Please contact us for the details.

Anchoring strand tension measurement

KCC-NA Center-hole type Compression Load Cell

Civil engineering design

Made-to-order

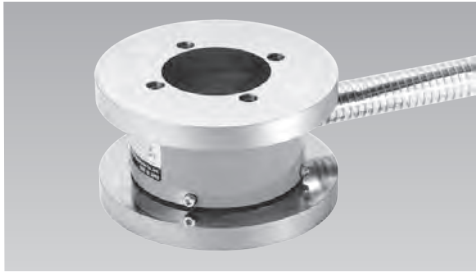

Large center-hole diameter
Flange-mounted

The KCC-NA is a center-hole-type load cell with flanges. The large diameter of its center hole makes this load cell suitable for use in almost all anchoring methods. It can deliver stable measurement performance under a relatively high eccentric load. Protection ratings: IP67 equivalent

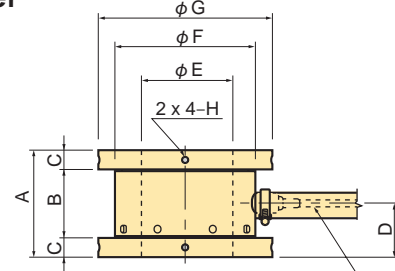

Input/Output cable
Protective tube (Outer: $\phi 33\text{mm}$) 0.3m

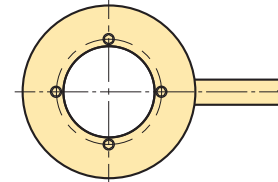

SPECIFICATIONS

TYPE	KCC-200KNA	KCC-500KNA	KCC-1MNA
Capacity	200kN	500kN	1MN
Rated Output	1mV/V (2000×10^{-6} strain) $\pm 10\%$		
Non-linearity	1%RO		
Hysteresis	1%RO		
Temperature effect on zero	0.1%RO/ $^{\circ}\text{C}$		
Temperature effect on span	0.05%/ $^{\circ}\text{C}$		
Compensated temperature range	-10 ~ +60 $^{\circ}\text{C}$		
Allowable temperature range	-20 ~ +70 $^{\circ}\text{C}$		
Over load	120%		
Input/Output resistance	350 $\Omega \pm 1\%$		
Recommended exciting voltage	10V or less		
Allowable exciting voltage	20V		
Zero balance	5%RO		
Weight	13kg	20kg	32kg

Input/Output cable : $\phi 9\text{mm}$ 0.5mm² 4-core shielded chloroprene cable 5m

DIMENSIONS

TYPE	A	B	C	D	ϕE	ϕF	ϕG	H
KCC-200KNA	108	68	20	54	90	145	190	-
KCC-500KNA	140	90	25	70	120	185	230	M 8 DP20
KCC-1MNA	183	123	30	92	140	220	250	M12 DP20

KCG-200KNA Center-hole type Compression Load Cell

Civil engineering design



Small size
Light weight
Low price

Protection ratings: IP67 equivalent

Small and inexpensive center-hole load cell enabling installation at the strand anchoring part in bridges, etc.

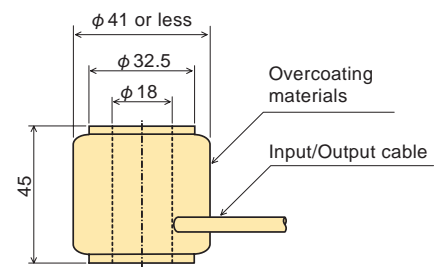
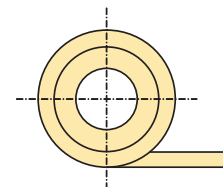

SPECIFICATIONS

TYPE	KCG-200KNA
Capacity	200kN
Rated Output	2.25mV/V (4500×10^{-6} strain) $\pm 10\%$
Non-linearity	0.5%RO
Hysteresis	0.5%RO
Temperature effect on zero	0.1%RO/ $^{\circ}\text{C}$
Temperature effect on span	0.05%/ $^{\circ}\text{C}$
Compensated temperature range	-10 ~ +60 $^{\circ}\text{C}$
Allowable temperature range	-30 ~ +70 $^{\circ}\text{C}$
Over load	120%
Ultimate overload rating	200%
Input/Output resistance	350 Ω
Recommended exciting voltage	10V or less
Allowable exciting voltage	20V
Zero balance	5%RO
Weight	250g

Input/Output cable : $\phi 3\text{mm}$ 0.05mm² 4-core shielded chloroprene cable 2m



Strand post-tension measurement

KCK-NA Center-hole type Compression Load Cell

Civil engineering design

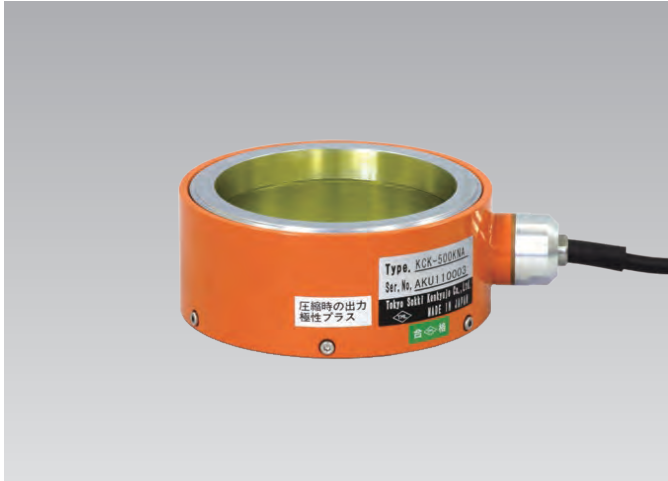

The KCK-NA is a center-hole type load cell designed to use in tension measurement of strand post-tensioning anchor such as lift-off testing and monitoring of existing anchor.

Protection ratings: IP67 equivalent

N.B.: The measured value of this load cell shows "+" polarity with increase in compression load.

- Large center-hole
- Lightweight
- Low profile

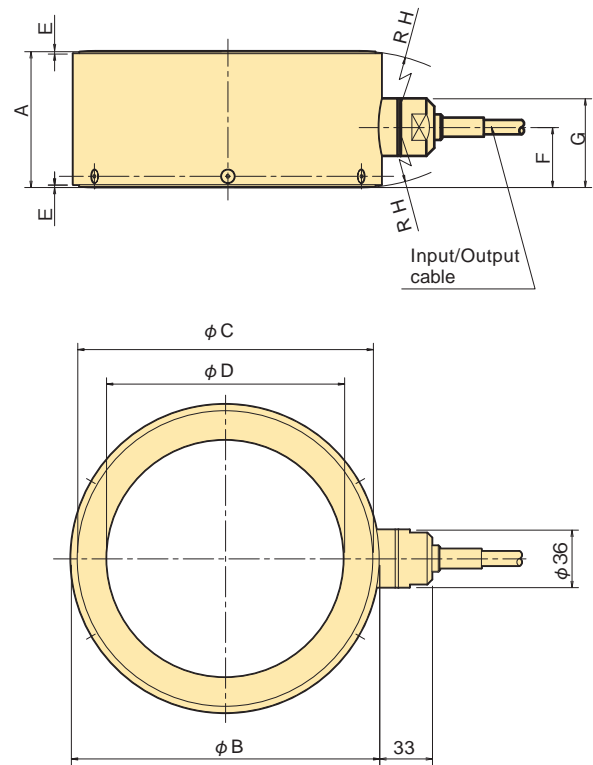

■ DIMENSIONS

TYPE	A	φB	φC	φD	E	F	G	H
KCK-500KNA	65	155	140	120	1.5	32.5	50.5	75
KCK-1MNA	85	193	185	149	1.5	37.5	55.5	110

■ SPECIFICATIONS

TYPE	KCK-500KNA	KCK-1MNA
Capacity	500kN	1MN
Rated Output	1.25mV/V (2500×10 ⁻⁶ strain) ±10%	1.4mV/V (2800×10 ⁻⁶ strain) ±10%
Non-linearity	1%RO	
Hysteresis	1%RO	
Temperature effect on zero	0.1%RO/°C	
Temperature effect on span	0.05%/°C	
Compensated temperature range	-10 ~ +60°C	
Allowable temperature range	-30 ~ +70°C	
Over load	120%	
Ultimate overload rating	200%	
Input/Output resistance	350Ω±1%	
Recommended exciting voltage	10V or less	
Allowable exciting voltage	20V	
Zero balance	5%RO	
Weight	3.0kg	5.5kg

Input/Output cable : φ9mm 0.5mm² 4-core shielded chloroprene cable 5m

CLL-NA Compression Load Cell 500kN~1MN

Civil engineering design



Loading test on cylindrical concrete specimen

The CLL-NA with a flat loading platform is used to conduct loading tests on cylindrical concrete test specimens. A cylindrical concrete specimen can be directly set on the surface of the loading platform.

Protection ratings: IP65 equivalent

■ DIMENSIONS

TYPE	A	φB	φC	φD	E	F	φG	H	I	J	K	L
CLL-500KNA	115	160	140	130	25	1	102	M10 DP10	80	45	-	-
CLL-1MNA	155	220	190	180	25	2	153	M12 DP15	124	65	280	120

■ SPECIFICATIONS

TYPE	CLL-500KNA	CLL-1MNA
Applicable specimen	φ 10 x 20cm	φ 15 x 30cm
Capacity	500kN	1MN
Rated Output	1.5mV/V (3000×10 ⁻⁶ strain) ±0.5%	
Non-linearity	0.2%RO	
Hysteresis	0.2%RO	
Temperature effect on zero	0.01%RO/°C	
Temperature effect on span	0.01%/°C	
Compensated temperature range	-10 ~ +60°C	
Allowable temperature range	-20 ~ +70°C	
Over load	150%	
Input/Output resistance	350Ω±5%	
Recommended exciting voltage	10V or less	
Allowable exciting voltage	20V	
Zero balance	5%RO	
Weight	9kg	22kg

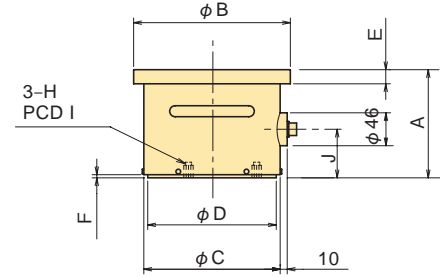
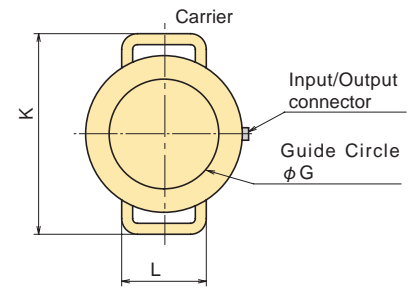

Supplied cable :

CT9-4N10/WP-STB (φ9mm 0.5mm² 4-core shielded chloroprene cable 10m)

CLH-NA Compression Load Cell 1~2MN

Civil engineering design



Loading test on cylindrical concrete specimen

The CLH-NA is designed mainly to test a cylindrical test specimen made of high-strength concrete. By using this load cell together with the compressometer, it is possible to measure load and strain simultaneously.

Protection ratings: IP65 equivalent

■ DIMENSIONS

TYPE	A	φB	φC	φD	E	F	φG	H	I	J	K	L
CLH-1MNA	115	160	140	130	25	1	102	M10 DP10	80	45	-	-
CLH-1.5MNA	137	195	170	160	25	2	127	M10 DP12	96	55	254	114
CLH-2MNA	155	220	190	180	25	2	153	M12 DP15	124	65	280	120

■ SPECIFICATIONS

TYPE	CLH-1MNA	CLH-1.5MNA	CLH-2MNA
Applicable specimen	φ 10 x 20cm	φ 12.5 x 25cm	φ 15 x 30cm
Capacity	1MN	1.5MN	2MN
Rated Output	1.5mV/V (3000×10 ⁻⁶ strain) ±0.5%		
Non-linearity	0.2%RO		
Hysteresis	0.2%RO		
Temperature effect on zero	0.01%RO/°C		
Temperature effect on span	0.01%/°C		
Compensated temperature range	-10 ~ +60°C		
Allowable temperature range	-20 ~ +70°C		
Over load	150%		
Input/Output resistance	350Ω±5%		
Recommended exciting voltage	10V or less		
Allowable exciting voltage	20V		
Zero balance	5%RO		
Weight	10kg	14kg	26kg

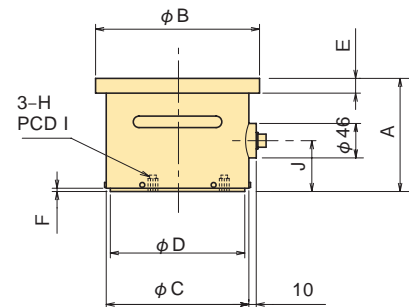
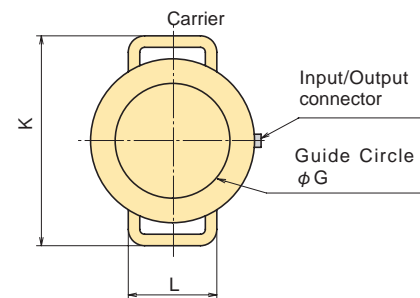

Supplied cable :

CT9-4N10/WP-STB (φ9mm 0.5mm² 4-core shielded chloroprene cable 10m)

LOAD CELLS

TCLZ-NA Tension/Compression Universal Load Cell 10N~10kN



The TCLZ-NA Tension/Compression Universal Load Cell is a high precision load cell that is compact and light weight. With its beam type internal structure, it is widely used as a sensor for controlling industrial machinery.

Protection ratings: IP41 equivalent

**High precision
Various capacities**

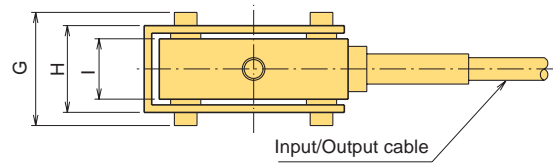
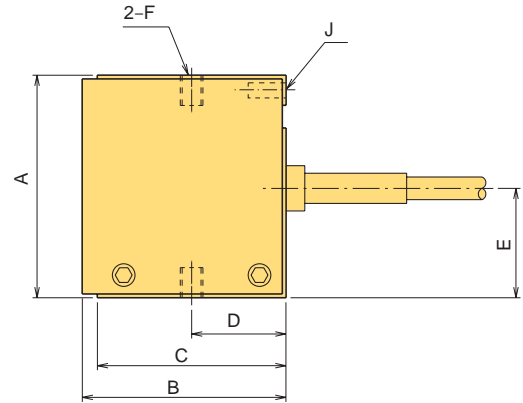

■ DIMENSIONS

TYPE	A	B	C	D	E	F	G	H	I	J
TCLZ-10NA	59	84	80	40	29.5	M6 x 1 DP8	28	21	14	φ4 DP10
TCLZ-20NA	59	84	80	40	29.5	M6 x 1 DP8	28	21	14	φ4 DP10
TCLZ-50NA	59	54	50	25	29.5	M6 x 1 DP8	30	23	16	φ4 DP10
TCLZ-100NA	59	54	50	25	29.5	M6 x 1 DP8	30	23	16	φ4 DP10
TCLZ-200NA	59	54	50	25	29.5	M6 x 1 DP8	30	23	16	φ4 DP10
TCLZ-500NA	67	54	50	25	33.5	M12 x 1.75 DP12	34	27	20	φ6 DP12
TCLZ-1KNA	67	54	50	25	33.5	M12 x 1.75 DP12	34	27	20	φ6 DP12
TCLZ-2KNA	67	54	50	25	33.5	M12 x 1.75 DP12	34	27	20	φ6 DP12
TCLZ-5KNA	75	60	56	28	37.5	M12 x 1.75 DP14	34	27	20	φ6 DP12
TCLZ-10KNA	75	60	56	28	37.5	M12 x 1.75 DP14	34	27	20	φ6 DP12

■ FITTING ACCESSORY

TYPE	Rotary attachment FD	Rod End FE	Eye Bolt FF	Load Button FG	Shackle FH
TCLZ-10NA~-200NA	FD-002	FE-002A	-	FG-002	-
TCLZ-500NA~-5KNA	FD-05A	FE-05A	FF-1	FG-05	FH-1B
TCLZ-10KNA	FD-1A	FE-1A	FF1	FG-05	FH-1B

Refer to pages 35~38 for load cell fitting accessories.

■ SPECIFICATIONS

TYPE	TCLZ-10NA	TCLZ-20NA	TCLZ-50NA	TCLZ-100NA	TCLZ-200NA	TCLZ-500NA	TCLZ-1KNA	TCLZ-2KNA	TCLZ-5KNA	TCLZ-10KNA
Capacity	10N	20N	50N	100N	200N	500N	1kN	2kN	5kN	10kN
Rated Output	1.25mV/V(2500×10 ⁻⁶ strain) ±0.5%		2mV/V (4000×10 ⁻⁶ strain) ±0.5%							
Non-linearity	0.05%RO		0.03%RO							0.05%RO
Hysteresis	0.05%RO		0.03%RO							0.05%RO
Natural frequency	0.14kHz	0.21kHz	0.45kHz	0.59kHz	0.87kHz	1.2kHz	1.7kHz	2.9kHz	3.5kHz	3.6kHz
Temperature effect on zero	0.01%/RO/°C					0.005%/RO/°C				
Temperature effect on span	0.005%/°C									
Compensated temperature range	-10 ~ +60°C									
Allowable temperature range	-20 ~ +70°C									
Over load	150%									
Input/Output resistance	350Ω±2%		350Ω±1%							
Recommended exciting voltage	6V or less									
Allowable exciting voltage	15V									
Zero balance	5%RO									
Weight	0.2kg	0.2kg	0.1kg	0.1kg	0.1kg	0.4kg	0.4kg	0.4kg	0.6kg	0.6kg

Input/Output cable : TCLZ-10NA/-20NA φ3mm 0.05mm² 4-core shielded chloroprene cable 5m
: Others φ6mm 0.35mm² 4-core shielded chloroprene cable 5m

TCLB-NA Tension/Compression Universal Load Cell 50~200N

Made-to-order



**Low capacity
High precision**

The TCLB-NA Tension/Compression Universal Load Cell is a low capacity load cell. It can be used for high precision measurement because the internal structure uses both ends fixed beam for the strain sensing element.

Protection ratings: IP40 equivalent TCLB-50NA
IP42 equivalent TCLB-100NA/-200NA

■ SPECIFICATIONS

TYPE	TCLB-50NA	TCLB-100NA	TCLB-200NA
Capacity	50N	100N	200N
Rated Output	1.5mV/V(3000×10 ⁻⁶ strain) ±0.5%		
Non-linearity	0.1%RO		
Hysteresis	0.1%RO		
Natural frequency	0.9kHz	1.4kHz	2kHz
Temperature effect on zero	0.01%RO/°C		
Temperature effect on span	0.01%/°C		
Compensated temperature range	-10 ~ +60°C		
Allowable temperature range	-20 ~ +70°C		
Over load	150%		
Input/Output resistance	350Ω±2%		
Recommended exciting voltage	6V or less		
Allowable exciting voltage	15V		
Zero balance	5%RO		
Weight	0.45kg		0.9kg

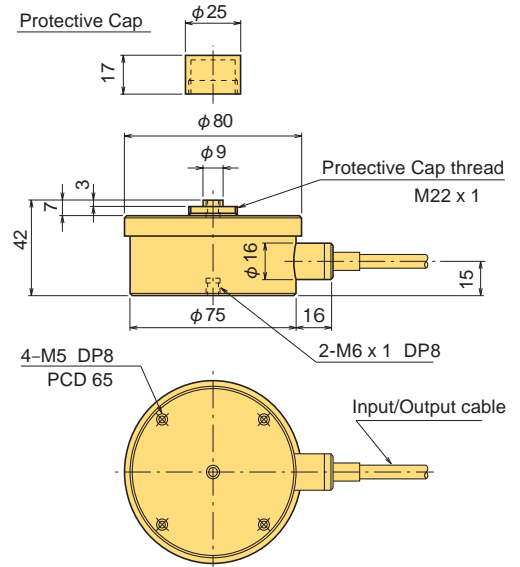

■ FITTING ACCESSORY

Spherical Cap FA	Mounting Flange FB	Rotary at-attachment FD	Rod End FE	Load Button FG
FA-20	FB-002-65	FD-002	FE-002A	FG-002

Refer to pages 35~38 for load cell fitting accessories.

Input/Output cable :
φ9mm 0.5mm² 4-core shielded chloroprene cable 5m

TCLA-NB Tension/Compression Universal Load Cell 500N~20kN



**Small size
Hermetically sealed**

The TCLA-NB Tension/Compression Universal Load Cell comes to much smaller and lightweight than conventional TCLA-NA. High capacity ranges of 10kN and 20kN are added on the line. It is hermetically sealed, enabling highly precise and consistent measurement.

Protection ratings: IP67 equivalent

■ SPECIFICATIONS

TYPE	TCLA-500NB	TCLA-1KNB	TCLA-2KNB	TCLA-5KNB	TCLA-10KNB	TCLA-20KNB
Capacity	500N	1kN	2kN	5kN	10kN	20kN
Rated Output	1.5mV/V(3000×10 ⁻⁶ strain) ±2%	1.5mV/V(3000×10 ⁻⁶ strain) ±1%	2.0mV/V(4000×10 ⁻⁶ strain) ±1%			
Non-linearity	0.3%RO	0.2%RO				
Hysteresis	0.1%RO					
Natural frequency	4.5kHz	6.7kHz	8.5kHz	13kHz	17kHz	16kHz
Temperature effect on zero	0.01%RO/°C					
Temperature effect on span	0.01%/°C					
Compensated temperature range	-10 ~ +60°C					
Allowable temperature range	-20 ~ +70°C					
Over load	150%			120%		
Input/Output resistance	350Ω±2%					
Recommended exciting voltage	6V or less					
Allowable exciting voltage	15V					
Zero balance	5%RO					
Weight	0.6kg				0.7kg	

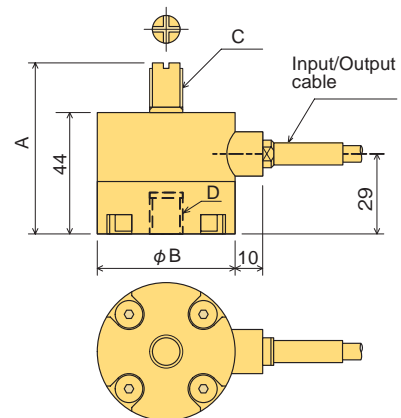

■ DIMENSIONS

TYPE	A	φB	C	D
TCLA-500NB ~ 10KNB	62	50	M12 x 1.75	M12 x 1.75 DP15
TCLA-20KNB	64	55	M18 x 1.5	M18 x 1.5 DP15

■ FITTING ACCESSORY

TYPE	Rotary at-attachment FD	Rod End FE
TCLA-500NB ~ 5KNB	FD-05B	FE - 0 5 A / FE-05B
TCLA-10KNB	FD-1B	FE-1A/FE-1B
TCLA-20KNB	FD-2B	FE-2A/FE-2B

Refer to pages 35~38 for load cell fitting accessories.
Input/Output cable :
φ6mm 0.35mm² 4-core shielded chloroprene cable 5m

LOAD CELLS

TCLY-NA Tension/Compression Universal Load Cell 300kN~2MN

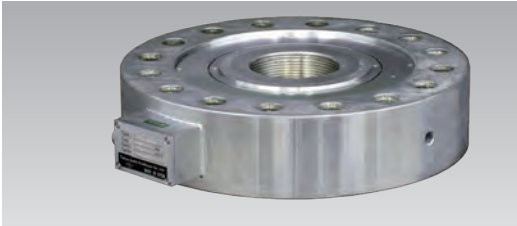

The TCLY-NA is a Tension/Compression Universal Load Cell with low-profile construction and high-capacity. It offers high precision, high output characteristics and an excellent stability because it uses a shear beam for the strain sensing element. This model is widely used in applications like one-axis loading test machine.

Low profile
High capacities

Protection ratings: IP40 equivalent

■ DIMENSIONS

TYPE	A	φB	φC	D	E	F	φG	φH	I	J
TCLY-300KNA	70	295	120	M65x3	35	33	198	17	245	M12 DP22
TCLY-500KNA	75	320	140	M85x3	37.5	33	220	22	270	M12 DP22
TCLY-1MNA	90	420	190	M110x3	45	34	278	26	350	M12 DP22
TCLY-1.5MNA	100	470	230	M140x4	50	34	318	32	395	M16 DP27
TCLY-2MNA	110	500	250	M160x4	55	34.5	338	38	420	M20 DP30

■ SPECIFICATIONS

TYPE	TCLY-300KNA	TCLY-500KNA	TCLY-1MNA	TCLY-1.5MNA	TCLY-2MNA	TCLY-5MNA	TCLY-10MNA
Capacity	300kN	500kN	1MN	1.5MN	2MN	5M	10M
Rated Output	2mV/V(4000×10 ⁻⁶ strain) ±0.5%						
Non-linearity	0.2%RO						
Hysteresis	0.2%RO					0.5%RO	
Natural frequency	4.8kHz	5.4kHz	4.8kHz	4.9kHz	5.2kHz		
Temperature effect on zero	0.01%RO/°C						
Temperature effect on span	0.005%/°C						
Compensated temperature range	0 ~ +40°C						
Allowable temperature range	-10 ~ +60°C						
Over load	150%						
Ultimate overload rating	300%						
Input/Output resistance	700Ω±1%						
Recommended exciting voltage	10V or less						
Allowable exciting voltage	20V						
Zero balance	5%RO						
Weight	35kg	40kg	80kg	100kg	125kg		

Supplied cable : CT9-4N10/NP-STB NDIS plug(φ 9mm 0.5mm² 4-core shielded chloroprene cable 10m)

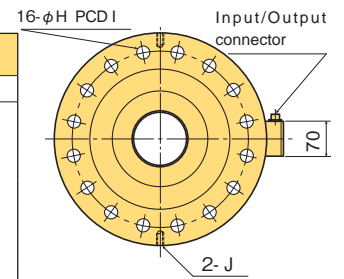
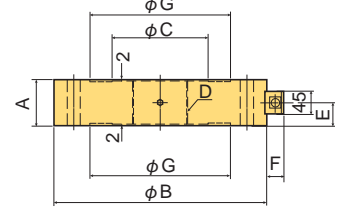

Build-to-order manufacturing

TCLN-NA Tension/Compression Universal Load Cell 500N~5kN



Small size
Hermetically sealed

Compared with TML ordinary Tension/Compression Universal Load Cells, the TCLN-NA is very small and light model. The Input/Output cable is as thin as 3mm in diameter for easiness to handle.

Protection ratings: IP67 equivalent

■ SPECIFICATIONS

TYPE	TCLN-500NA	TCLN-1KNA	TCLN-2KNA	TCLN-5KNA
Capacity	500N	1kN	2kN	5kN
Rated Output	1mV/V(2000×10 ⁻⁶ strain) ±20%			
Non-linearity	0.5%RO			
Hysteresis	0.1%RO			
Natural frequency	10kHz	12kHz	14kHz	14kHz
Temperature effect on zero	0.05%RO/°C			
Temperature effect on span	0.05%/°C			
Compensated temperature range	-10 ~ +60°C			
Allowable temperature range	-20 ~ +70°C			
Over load	150%			
Ultimate overload rating	200%			
Input/Output resistance	350Ω±2%			
Recommended exciting voltage	6V or less			
Allowable exciting voltage	15V			
Zero balance	10%RO			
Weight	80g	80g	80g	140g

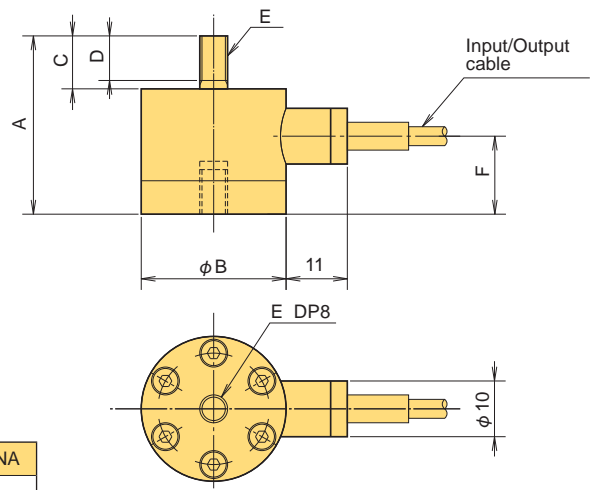

■ DIMENSIONS

TYPE	A	φB	C	D	E	F
TCLN-500NA	32	26	9.5	8	M5 x 0.8	14
TCLN-1KNA	32	26	9.5	8	M5 x 0.8	14
TCLN-2KNA	32	26	9.5	8	M5 x 0.8	14
TCLN-5KNA	42	32	14	12	M8 x 1.25	15

■ FITTING ACCESSORY

TYPE	Rod End FE
TCLN-500NA~2KNA	FE-002C/FE-002D
TCLN-5KNA	FE-05C/FE-05D

Refer to pages 35~38 for load cell fitting accessories.

Input/Output cable : φ 3mm 0.05mm² 4-core shielded chloroprene cable 5m

TCLK-NA Tension/Compression Universal Load Cell 5~50kN



Low profile Hermetically sealed

The TCLK-NA Tension/Compression Universal Load Cell has a low profile construction that serves to save installation space.
Protection ratings: IP67 equivalent

TCLK-5KNA

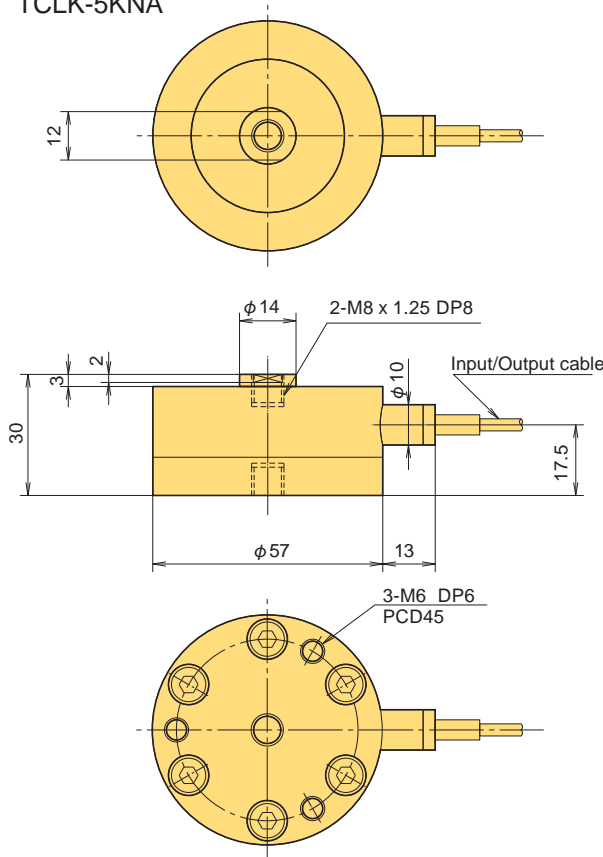

TCLK-10KNA~ 50KNA

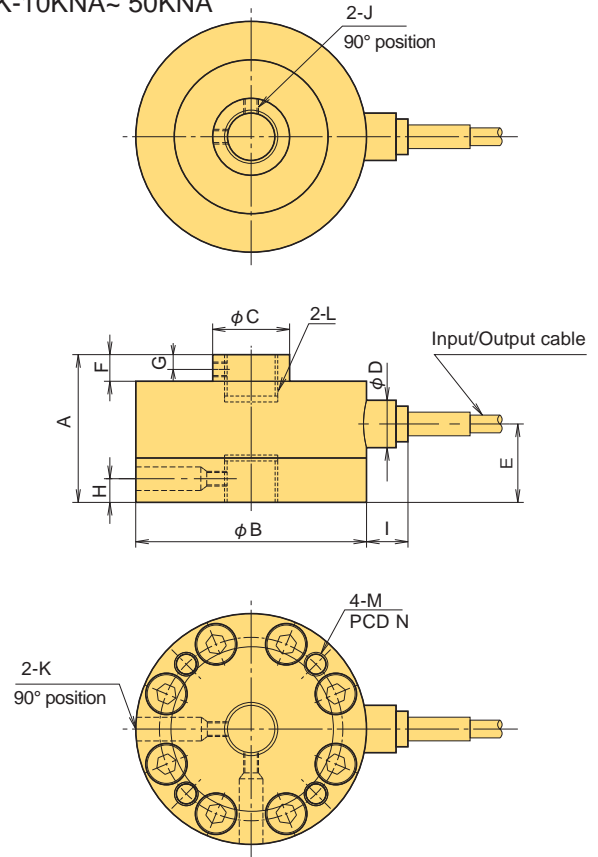

■ DIMENSIONS

TYPE	A	φB	φC	φD	E	F	G	H	I	J	K	L	M	N
TCLK-5KNA	As per the figure													
TCLK-10KNA	40	68	20	16	22	6	3	6	14	M3	M4 φ6 DP22	M12 x 1.75 DP13	M6 DP8	55
TCLK-20KNA	50	78	26	16	26.5	9	5	8	14	M5	M5 φ8 DP22	M18 x 1.5 DP16	M8 DP10	62
TCLK-50KNA	62	100	33	16	31	9	5	10	14	M5	M5 φ8 DP22	M24 x 2 DP20	M8 DP10	80

■ SPECIFICATIONS

TYPE	TCLK-5KNA	TCLK-10KNA	TCLK-20KNA	TCLK-50KNA
Capacity	5kN	10kN	20kN	50kN
Rated Output	2mV/V(4000×10 ⁻⁶ strain) ±1%			
Non-linearity	0.1%RO			
Hysteresis	0.1%RO			
Natural frequency	18kHz	17kHz	17kHz	14kHz
Temperature effect on zero	0.01%RO/°C			
Temperature effect on span	0.01%/°C			
Compensated temperature range	-10 ~ +60°C			
Allowable temperature range	-20 ~ +70°C			
Over load	150%			
Input/Output resistance	350Ω±2%			
Recommended exciting voltage	6V or less			
Allowable exciting voltage	15V			
Zero balance	5%RO			
Weight	0.45kg	0.8kg	1.3kg	2.6kg

■ FITTING ACCESSORY

TYPE	Spherical Cap FA	Rod End FE	Load Button FG
TCLK-5KNA	FA-20	FE-05C	FG-05B
TCLK-10KNA	FA-60	FE-1A	FG-1
TCLK-20KNA	FA-80	FE-2A	FG-2
TCLK-50KNA	FA-100	FE-5A	FG-5

Refer to pages 35~38 for load cell fitting accessories.

Input/Output cable :

TCLK-5KNA φ3mm 0.05mm² 4-core shielded chloroprene cable 5m
TCLK-10KNA~50KNA φ6mm 0.35mm² 4-core shielded chloroprene cable 5m

LOAD CELLS

TCLU-NA Tension/Compression Universal Load Cell

10~200kN

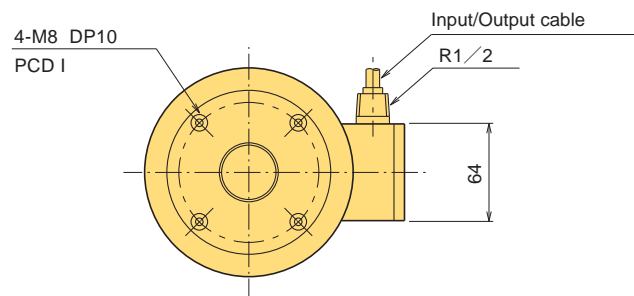
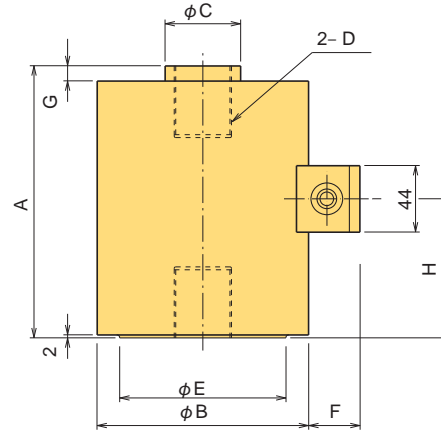

The TCLU-NA Tension/Compression Universal Load Cell is an inert-gas encased load cell in a hermetically sealed package. It can take highly precise and consistent measurements over long periods of time, and is used primarily in applications such as measuring crane and jack loads.

Protection ratings: IP65 equivalent

Inert gas hermetically sealed

■ DIMENSIONS

TYPE	A	φB	φC	D	φE	F	G	H	I
TCLU-10KNA	101	88	20	M12 x 1.75 DP15	70	28	8	49	58
TCLU-20KNA	111	100	26	M18 x 1.5 DP20	80	27	8	55	66
TCLU-50KNA	131	100	32	M24 x 2 DP30	80	26.8	8	65	66
TCLU-100KNA	181	138	50	M39 x 2 DP45	110	33	10	92	94
TCLU-200KNA	255	176	64	M50 x 2 DP65	150	34	12	130	130

■ FITTING ACCESSORY

TYPE	Spherical Cap FA	Rotary attachment FD	Rod End FE	Eye Bolt FF	Load Button FG	Shackle FH
TCLU-10KNA	FA-60	FD-1A	FE-1A	FF-1	FG-1	FH-1B
TCLU-20KNA	FA-80	FD-2A	FE-2A	FF-2	FG-2	FH-2B
TCLU-50KNA	FA-100	FD-5	FE-5A	FF-5	FG-5	FH-5B
TCLU-100KNA	FA-140	FD-10	FE-10A	FF-10	FG-10	FH-10B
TCLU-200KNA	FA-140	FD-20	FE-20A	FF-20B	FG-20	FH-20B

Refer to pages 35~38 for load cell fitting accessories.

■ SPECIFICATIONS

TYPE	TCLU-10KNA	TCLU-20KNA	TCLU-50KNA	TCLU-100KNA	TCLU-200KNA
Capacity	10kN	20kN	50kN	100kN	200kN
Rated Output	2mV/V(4000×10 ⁻⁶ strain) ±0.5%				
Non-linearity	0.15%RO				
Hysteresis	0.05%RO				
Natural frequency	4.8kHz	5.3kHz	6.0kHz	4.8kHz	2.4kHz
Temperature effect on zero	0.005%RO/°C				
Temperature effect on span	0.005%/°C				
Compensated temperature range	-10 ~ +60°C				
Allowable temperature range	-30 ~ +80°C				
Over load	150%				
Input/Output resistance	350Ω±1%				
Recommended exciting voltage	10V or less				
Allowable exciting voltage	20V				
Zero balance	5%RO				
Weight	4kg	4kg	4kg	11kg	18kg

Input/Output cable : φ9mm 0.5mm² 4-core shielded chloroprene cable 5m

TCLM-NB Tension/Compression Universal Load Cell 10~200kN



The TCLM-NB Tension/Compression Universal Load Cell is an inert-gas encased load cell in a hermetically sealed package. It offers high precision, high output characteristics and excellent stability because it uses a shear beam for the strain sensing element. The model is widely used in applications like test equipment

Protection ratings: IP65 equivalent

High precision
Inert gas hermetically sealed

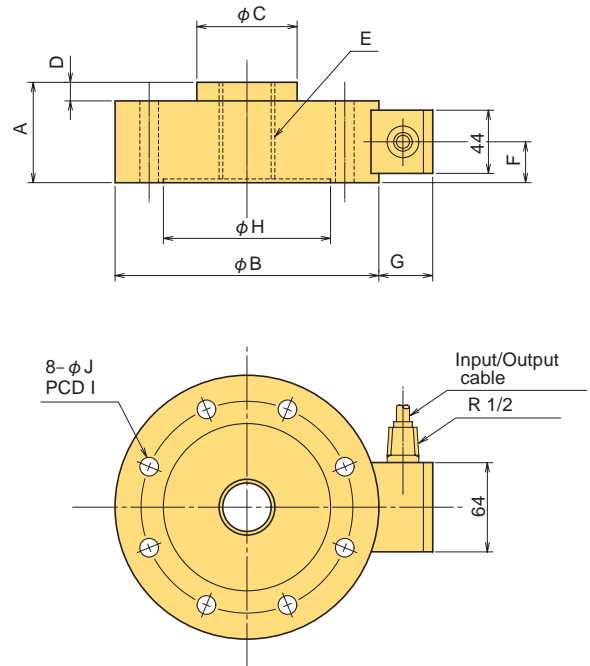

■ DIMENSIONS

TYPE	A	φB	φC	D	E	F	G	φH	I	φJ
TCLM-10KNB	60	118	26	8	M12 x 1.75	26	37	68	90	8.5
TCLM-20KNB	60	118	26	8	M18 x 1.5	26	37	68	90	8.5
TCLM-50KNB	60	127	32	8	M24 x 2	26	37	76	100	8.5
TCLM-100KNB	70	187	70	12	M39 x 2	29	38	116	150	13
TCLM-200KNB	85	226	94	12	M50 x 2	37	38.3	146	185	17

■ FITTING ACCESSORY

TYPE	Spherical Cap FA	Mounting Flange FB	Rotary attachment FD	Rod End FE	Eye Bolt FF	Load Button FG	Shackle FH
TCLM-10KNB	FA-60	FB-1M	FD-1A	FE-1A	FF-1	FG-1	FH-1B
TCLM-20KNB	FA-80	FB-2M	FD-2A	FE-2A	FF-2	FG-2	FH-2B
TCLM-50KNB	FA-100	FB-5M	FD-5	FE-5A	FF-5	FG-5	FH-5B
TCLM-100KNB	FA-140	FB-10M	FD-10	FE-10A	FF-10	FG-10	FH-10B
TCLM-200KNB	FA-140	FB-20M	FD-20	FE-20A	FF-20B	FG-20	FH-20B

Refer to pages 35~38 for load cell fitting accessories.

■ SPECIFICATIONS

TYPE	TCLM-10KNB	TCLM-20KNB	TCLM-50KNB	TCLM-100KNB	TCLM-200KNB
Capacity	10kN	20kN	50kN	100kN	200kN
Rated Output	2.5mV/V/(5000×10 ⁻⁶ strain) ±0.5%				
Non-linearity	0.05%RO				
Hysteresis	0.05%RO				
Natural frequency	1.4kHz	6.3kHz	8.2kHz	6.9kHz	5.6kHz
Temperature effect on zero	0.002%RO/°C				
Temperature effect on span	0.002%/°C				
Compensated temperature range	-10 ~ +60°C				
Allowable temperature range	-30 ~ +80°C				
Over load	150%				
Input/Output resistance	350Ω±1%				
Recommended exciting voltage	10V or less				
Allowable exciting voltage	20V				
Zero balance	5%RO				
Weight	4kg	4kg	6kg	10kg	17kg

Input/Output cable : φ9mm 0.5mm² 4-core shielded chloroprene cable 5m

LOAD CELLS

TCLP-NB Tension/Compression Universal Load Cell

10kN ~2MN



General purpose Various capacities

The TCLP-NB Tension/Compression Universal Load Cell is a load cell widely used in applications such as measuring crane and jack loads because it offers excellent consistency.

Two independent output type is available on request.

Protection ratings: IP65 equivalent

TCLP-10 ~ 200KNB

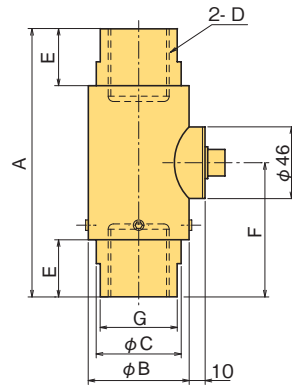

TCLP-300-/500KNB

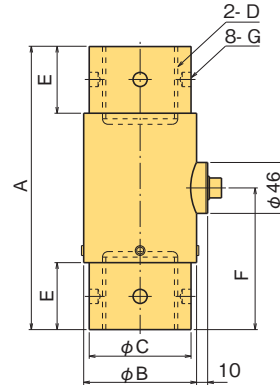

TCLP-1 ~ 2MNB

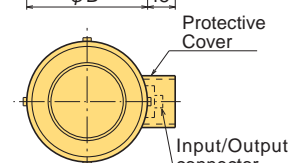
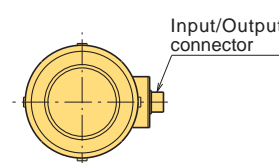
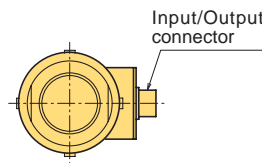
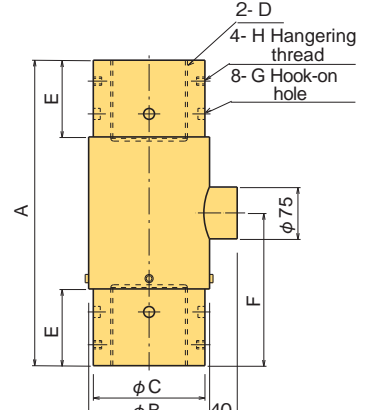

■ DIMENSIONS

TYPE	A	φB	φC	D	E	F	G	H
TCLP-10KNB	100	55	45	M12 x 1.75 DP15	15	53	36	-
TCLP-20KNB	110	60	50	M18 x 1.5 DP20	20	58	46	-
TCLP-30KNB	125	60	50	M24 x 2 DP30	20	63	46	-
TCLP-50KNB	125	60	50	M24 x 2 DP30	20	63	46	-
TCLP-100KNB	175	65	55	M39 x 2 DP45	37.5	87.5	50	-
TCLP-200KNB	255	80	70	M50 x 2 DP65	65	127.5	65	-
TCLP-300KNB	255	100	90	M65 x 3 DP65	60	127.5	φ13 DP8	-
TCLP-500KNB	330	130	120	M85 x 3 DP85	80	165	φ15 DP10	-
TCLP-1MNB	440	175	160	M110 x 3 DP110	108	220	φ15 DP10	M12 DP12
TCLP-1.5MNB	530	215	200	M140 x 4 DP140	155	265	φ20 DP10	M16 DP20
TCLP-2MNB	605	245	230	M160 x 4 DP160	194	302.5	φ20 DP10	M20 DP25

■ FITTING ACCESSORY

TYPE	Spherical Cap FA	Rotary attachment FD	Rod End FE	Eye Bolt FF	Load Button FG	Shackle FH
TCLP-10KNB	FA-60	FD-1A	FE-1A	FF-1	FG-1	FH-1B
TCLP-20KNB	FA-80	FD-2A	FE-2A	FF-2	FG-2	FH-2B
TCLP-30-/50KNB	FA-100	FD-5	FE-5A	FF-5	FG-5	FH-5B
TCLP-100KNB	FA-140	FD-10	FE-10A	FF-10	FG-10	FH-10B
TCLP-200KNB	FA-140	FD-20	FE-20A	FF-20B	FG-20	FH-20B

■ SPECIFICATIONS

Refer to pages 35~38 for load cell fitting accessories.

TYPE	TCLP-10KNB	TCLP-20KNB	TCLP-30KNB	TCLP-50KNB	TCLP-100KNB	TCLP-200KNB	TCLP-300KNB	TCLP-500KNB	TCLP-1MNB	TCLP-1.5MNB*	TCLP-2MNB*
Capacity	10kN	20kN	30kN	50kN	100kN	200kN	300kN	500kN	1MN	1.5MN	2MN
Rated Output	1mV/V(2000×10 ⁻⁶ strain) ±0.5%										
Non-linearity	0.1%RO									0.3%RO	
Hysteresis	0.1%RO									0.3%RO	
Natural frequency	6.8kHz	7.9kHz	8.3kHz	10kHz	10kHz	7.7kHz	6.7kHz	5.3kHz	4kHz	3.1kHz	2.6kHz
Temperature effect on zero	0.01%RO/°C										
Temperature effect on span	0.005%/°C										
Compensated temperature range	-10 ~ +60°C										
Allowable temperature range	-20 ~ +70°C										
Over load	200%										
Input/Output resistance	350Ω±1%										
Recommended exciting voltage	10V or less										
Allowable exciting voltage	20V										
Zero balance	5%RO										
Weight	1.5kg	1.5kg	2kg	2kg	2.5kg	5kg	8kg	15kg	50kg	85kg	110kg

Supplied cable : CT9-4N10/WP-STB (φ9mm 0.5mm² 4-core shielded chloroprene cable 10m)

*Made-to-order

TLJ-NA Tension Load Cell

10~100kN

Made-to-order



The TLJ-NA Tension Load Cell is designed considering JIS B7721 "Tension/compression testing machines - Verification and calibration of the force-measuring system" and JIS B 7728 "Calibration of force-proving instruments used for the verification of uniaxial testing machine" and is the most suitable for verification of single axis tension testing machine. Calibration in accordance with JIS B 7721 and JIS B 7728 is available at extra cost.

Protection ratings: IP65 equivalent

High stability

Remote sensing compatible

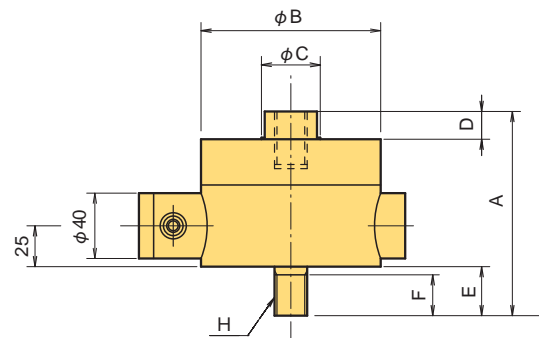
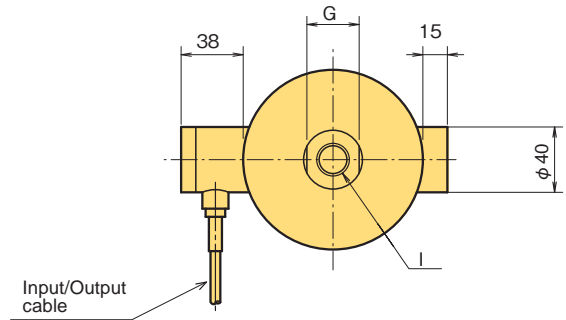

■ DIMENSIONS

TYPE	A	φB	φC	D	E	F	G	H	I
TLJ-10KNA	125	110	36	17	30	25	32	M20 x 1.5	M20 x 1.5 DP35
TLJ-20KNA	125	110	36	17	30	25	32	M20 x 1.5	M20 x 1.5 DP35
TLJ-50KNA	132	125	36	17	35	30	32	M20 x 1.5	M20 x 1.5 DP35
TLJ-100KNA	142	145	42	17	40	34	36	M24 x 2	M24 x 2 DP35

■ FITTING ACCESSORY

TYPE	Rod End FE
TLJ-10KNA ~ 50KNA	FE-5C/FE-5D
TLJ-100KNA	FE-5A/FE-5B

Refer to pages 35~38 for load cell fitting accessories.

■ SPECIFICATIONS

TYPE	TLJ-10KNA	TLJ-20KNA	TLJ-50KNA	TLJ-100KNA
Capacity	10kN	20kN	50kN	100kN
Rated Output	2mV/V/(4000×10 ⁻⁶ strain) or more			
Non-linearity	0.03%RO			
Hysteresis	0.03%RO			
Natural frequency	3.5kHz	4.4kHz	4.5kHz	4.7kHz
Temperature effect on zero	0.005%/RO/°C			
Temperature effect on span	0.005%/°C			
Compensated temperature range	-10 ~ +60°C			
Allowable temperature range	-30 ~ +80°C			
Over load	120%			
Ultimate overload rating	200%			
Input/Output resistance	350Ω±2%			
Recommended exciting voltage	6V or less			
Allowable exciting voltage	15V			
Zero balance	5%RO			
Weight	5.3kg	5.3kg	6.9kg	10kg

Input/Output cable : φ6mm 0.08mm² 6-core shielded polyurethane cable 5m (Remote sensing compatible)

LOAD CELLS

TLP-NB Tension Load Cell

10kN~1MN



The TLP-NB Tension Load Cell is a tension-only load cell that is used primarily in applications such as measuring tension on wire rope or loads suspended from cranes. Eyebolts integrated into the main unit facilitate mounting simply by attaching shackles.

Protection ratings: IP65 equivalent

Eyebolts integrated type

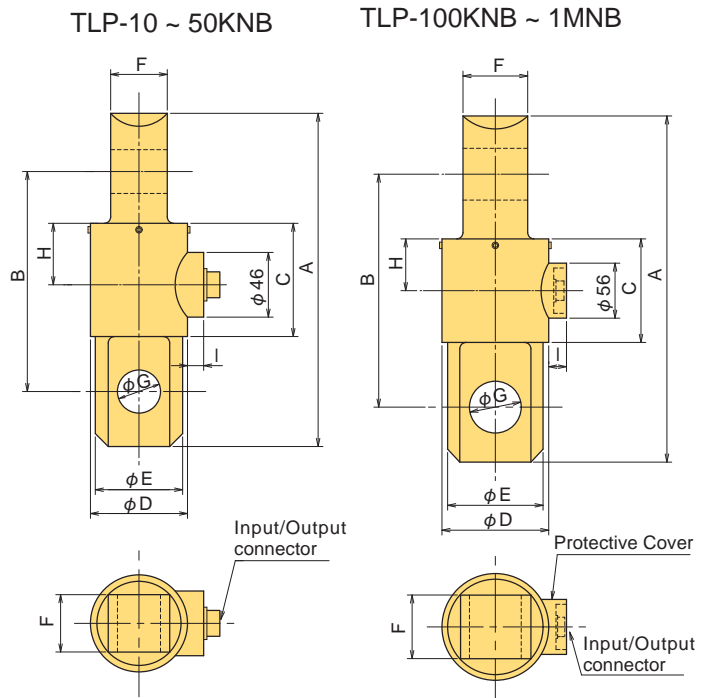

■ DIMENSIONS

TYPE	A	B	C	φD	φE	F	φG	H	I
TLP-10KNB	140	110	69	50	32	20	18	39	10
TLP-20KNB	164	122	71	50	40	25	22	40	10
TLP-30KNB	179	127	63	60	50	30	27	34	10
TLP-50KNB	234	168	80	70	60	40	37	44	10
TLP-100KNB	292	200	86	95	85	56	49	47	35
TLP-200KNB	358	244	108	112	100	68	54	56	35
TLP-300KNB	428	288	128	135	120	75	64	64	35
TLP-500KNB	508	342	148	160	145	98	75	74	35
TLP-1MNB	690	450	210	210	195	130	102	105	35

■ FITTING ACCESSORY

TYPE	Shackle FH
TLP-10KNB	FH-1B
TLP-20KNB	FH-2B
TLP-30KNB	FH-3B
TLP-50KNB	FH-5B
TLP-100KNB	FH-10B
TLP-200KNB	FH-20B
TLP-300KNB	FH-30B
TLP-500KNB	FH-50B
TLP-1MNB	FH-100B

Refer to pages 35~38 for load cell fitting accessories.

■ SPECIFICATIONS

TYPE	TLP-10KNB	TLP-20KNB	TLP-30KNB	TLP-50KNB	TLP-100KNB	TLP-200KNB	TLP-300KNB*	TLP-500KNB*	TLP-1MNB*
Capacity	10kN	20kN	30kN	50kN	100kN	200kN	300kN	500kN	1MN
Rated Output	1mV/V(2000×10 ⁻⁶ strain) ±0.5%								
Non-linearity	0.1%RO								
Hysteresis	0.1%RO								
Natural frequency	11kHz	9.5kHz	6.0kHz	4.8kHz	4.0kHz	3.7kHz	3.2kHz	2.7kHz	2.0kHz
Temperature effect on zero	0.01%RO/°C								
Temperature effect on span	0.005%/°C								
Compensated temperature range	-10 ~ +60°C								
Allowable temperature range	-20 ~ +70°C								
Over load	200%								
Input/Output resistance	350Ω±1%								
Recommended exciting voltage	10V or less								
Allowable exciting voltage	20V								
Zero balance	5%RO								
Weight	1kg	1.5kg	2kg	4kg	8kg	14kg	24kg	38kg	110kg

Supplied cable : CT9-4N10/WP-STB (φ9mm 0.5mm² 4-core shielded chloroprene cable 10m) *Made-to-order

MULTI-COMPONENT LOAD CELLS

3-Component Load Cell SLP-NA-T 100N/200N/500N/1kN Made-to-order



The SLP-NA-T is a strain gauge based load cell for simultaneous measurement of forces in three mutually perpendicular axes. Since the load cell is constructed small and light, it is well suited to use in model testing.

Protection ratings: IP65 equivalent

Small and light

High frequency response

Easy handling

Applicable to wind tunnel testing and vibration testing of models

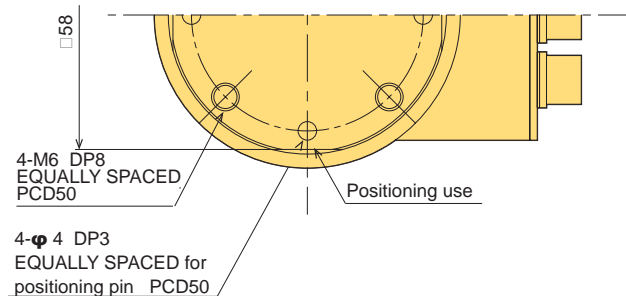
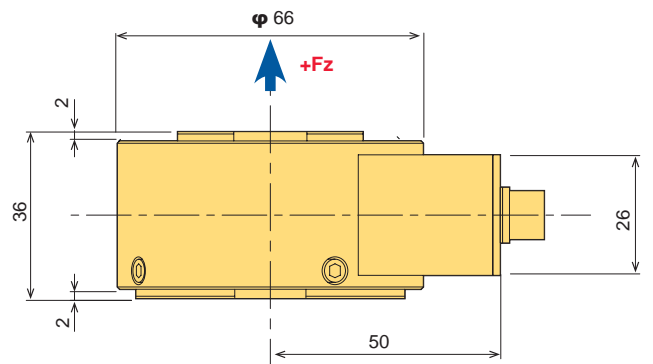
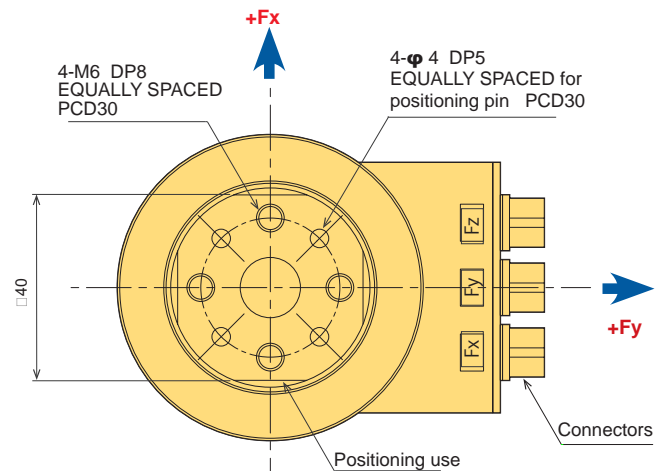

■ SPECIFICATIONS

TYPE	SLP-100NA-T	SLP-200NA-T	SLP-500NA-T	SLP-1KNA-T
Capacity Fx, Fy, Fz	100N	200N	500N	1kN
Rated Output	Approx. 0.5mV/V (Approx. 1000x10 ⁻⁶ strain)			
Non-linearity	0.5%RO			
Hysteresis	0.5%RO			
Cross sensitivity	2%RO			
Temperature effect on zero	0.05%RO/°C			
Temperature effect on span	0.05%/°C			
Compensated temperature range	-10 ~ +60°C (No icing)			
Allowable temperature range	-20 ~ +80°C (No icing)			
Over Load	150%			
Ultimate overload rating	200%			
Input/Output resistance	350Ω			
Recommended exciting voltage	2V or less			
Allowable exciting voltage	15V			
Zero balance	20%RO			
Weight	Approx. 300g		Approx. 800g	

Supplied cable : ϕ 4mm 0.09mm² 4-core shielded vinyl cable 5m, 3 pcs.

LOAD CELLS

LTA-NA Torque Transducer 50~500N·m



Fastening torque measurement for bolts and nuts

The LTA-NA Torque Transducer is a high precision transducer that is used to measure tightening force on nuts and bolts. Compact and light weight, it is mounted between the socket and the socket wrench handle. Although the transducer uses a strainmeter to take readings, it can be used to take peak readings simply by connecting it to a peak hold measuring instrument.

LTA-50 ~ -200NA

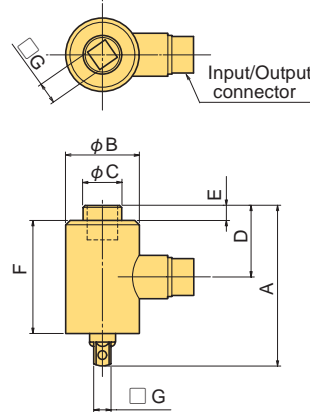

LTA-500NA

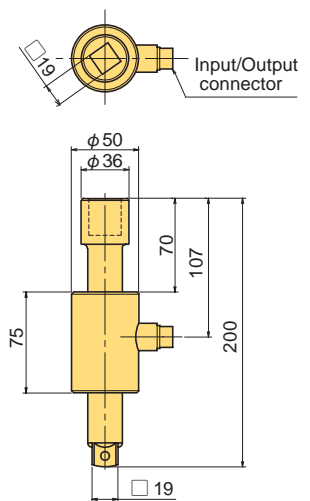

■ SPECIFICATIONS

TYPE	LTA-50NA	LTA-100NA	LTA-200NA	LTA-500NA
Capacity	50N·m	100N·m	200N·m	500N·m
Rated Output	2mV/V(4000×10 ⁻⁶ strain) ±2%		3mV/V (6000×10 ⁻⁶ strain) ±2%	2mV/V(4000×10 ⁻⁶ strain) ±2%
Non-linearity	0.3%RO			
Temperature effect on zero	0.1%RO/°C			
Temperature effect on span	0.05%/°C			
Compensated temperature range	-10 ~ +60°C			
Allowable temperature range	-10 ~ +60°C			
Input/Output resistance	350Ω±1%			
Recommended exciting voltage	3V or less			
Allowable exciting voltage	10V			
Zero balance	10%RO			
Over Load	120%			
Weight	0.25kg	0.3kg	0.3kg	1.5kg

■ DIMENSIONS

TYPE	A	φB	φC	D	E	F	□G
LTA-50NA	75	34	18	35	7	52	9.5
LTA-100NA	75	34	23.5	38	9	48	12.7
LTA-200NA	75	34	23.5	38	9	48	12.7
LTA-500NA	As per the figure						

Protection ratings: IP40 equivalent

Supplied cable :

CT6-4V5/NP-STB (φ6mm 0.3mm² 4-core shielded vinyl cable 5m)

LTB-NA Torque Transducer 10N·m~1kN·m



Flange mounting type

The LTB-NA Torque Transducer is a flange-mounted transducer that is installed between non-rotating measuring items in order to detect torque in the items.

Protection ratings: IP30 equivalent

■ DIMENSIONS

TYPE	A	φB	φC	φD	E	F	φG	H
LTB-10NA	55	105	20 H8	45	5	3	5.5	90
LTB-20NA	55	105	20 H8	45	5	3	5.5	90
LTB-30NA	55	105	20 H8	45	5	3	5.5	90
LTB-50NA	55	105	20 H8	45	5	3	5.5	90
LTB-100NA	75	115	20 H8	55	8	3	8.5	95
LTB-200NA	75	115	20 H8	55	8	3	8.5	95
LTB-300NA	75	115	20 H8	55	8	3	8.5	95
LTB-500NA	90	130	30 H8	60	10	3	10.5	110
LTB-1KNA	105	140	30 H8	70	12	3	12.5	115

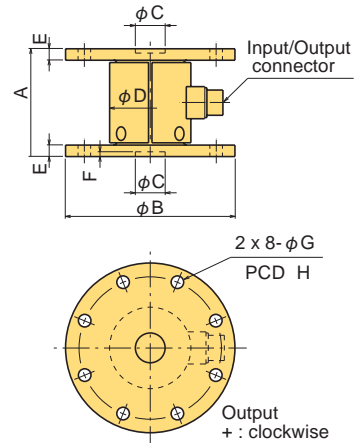

■ SPECIFICATIONS

TYPE	LTB-10NA	LTB-20NA	LTB-30NA	LTB-50NA	LTB-100NA	LTB-200NA*	LTB-300NA*	LTB-500NA*	LTB-1KNA*
Capacity	10N·m	20N·m	30N·m	50N·m	100N·m	200N·m	300N·m	500N·m	1kN·m
Rated Output	1mV/V(2000×10 ⁻⁶ strain) ±2%								
Non-linearity	0.3%RO								
Hysteresis	0.3%RO								
Temperature effect on zero	0.01%RO/°C								
Temperature effect on span	0.005%/°C								
Compensated temperature range	0 ~ +40°C								
Allowable temperature range	-10 ~ +60°C								
Over load	150%								
Input/Output resistance	350Ω±1%								
Recommended exciting voltage	6V or less								
Allowable exciting voltage	10V								
Zero balance	5%RO								
Weight	1kg	1kg	1kg	1kg	2kg	2kg	2kg	3kg	5kg

Supplied cable :CT6-4V5/NP-STB (φ6mm 0.3mm² 4-core shielded vinyl cable 5m) *Made-to-order

LOAD CELL FITTING ACCESSORY

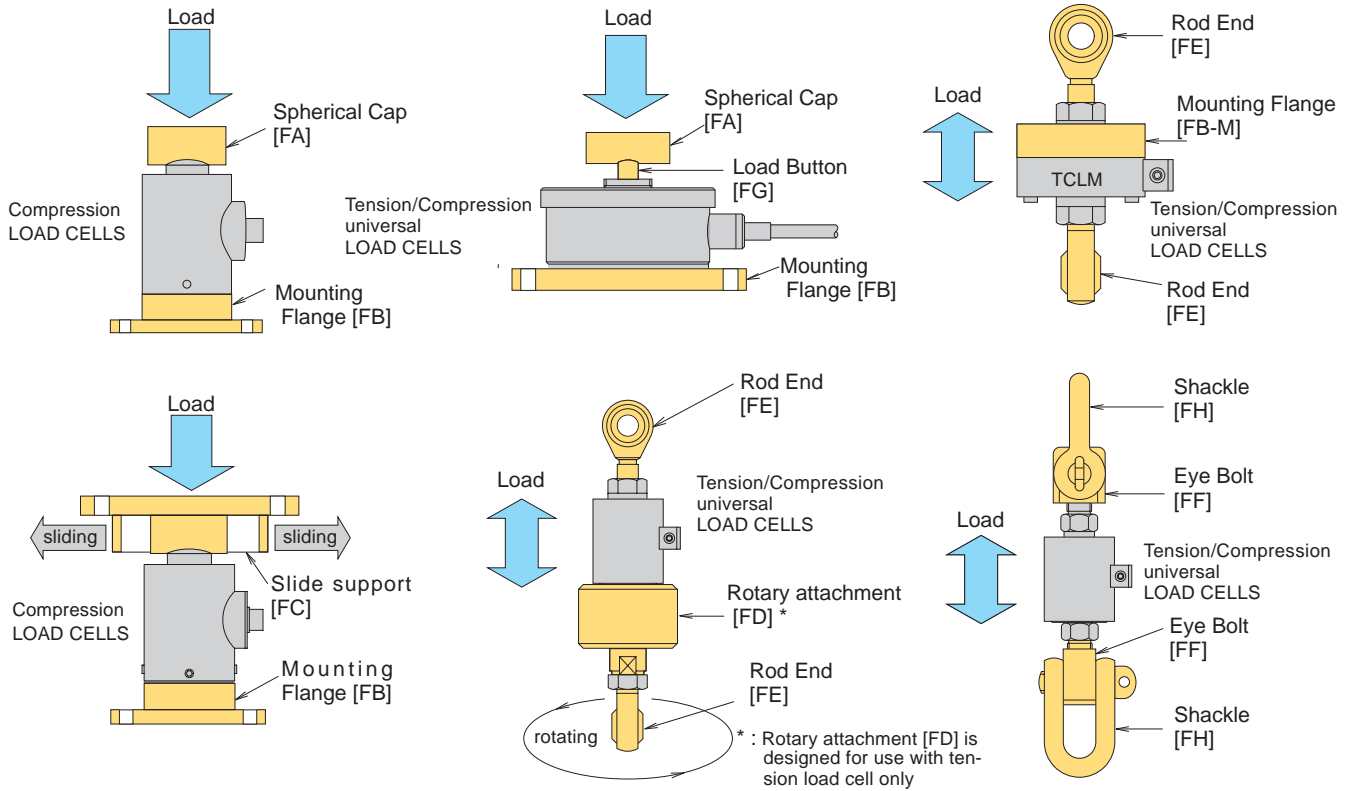

Compression Load Cells	Fitting accessory		
	Spherical Cap FA	Mounting Flange FB	Slide Support FC
CLA-500NA ~ 20KNA	FA-20	FB-2-44	FC-2-20
CLP-10, -20KNB	FA-60	FB-10-30	FC-5-60
-30, -50KNB (-D)**	FA-60	FB-10-30	FC-5-60
-100KNB (-D)**	FA-80	FB-10-30	FC-20-80
-200KNB (-D)**	FA-100	FB-20-40	FC-20-100
-300, -500KNB (-D)**	FA-140	FB-50-60	FC-50-140
-1MNB (-D)**	FA-160	FB-100-80	-
-2MNB (-D)**	FA-250	FB-200-100	-
-3MNB (-D)**	FA-360	FB-300-120	-
-5MNB (-D)**	FA-360B	FB-500-140	-
-10MNB	FA-720	FB-1000-200	-
CLG-10, -20KNB	FA-60	FB-2-70	FC-5-60
-50KNB	FA-60	FB-5-82	FC-5-60
-100KNB	FA-80	FB-10-90	FC-20-80
-200KNB	FA-100	FB-20-100	FC-20-100
CLM-10KNB ~ 50KNB	FA-60	FB-5-80	FC-5-60
-100KNB	FA-80	FB-10-90	FC-20-80
-200KNB	FA-100	FB-20-120	FC-20-100
-500KNB	FA-140	FB-50-150	FC-50-140
CLU-10KNA ~ 50KNA	FA-60	FB-5-54	FC-5-60
-100KNA (-D)**	FA-80	FB-10-60	FC-20-80
-200KNA (-D)**	FA-100	FB-20-70	FC-20-100
-500KNA (-D)**	FA-140	FB-50-100	FC-50-140
-1MNA (-D)**	FA-160	FB-100-104	-
CLR-500NAH ~ -200KNAH	FA-20	FB-2-44	FC-2-20
-50KNAH	FA-60	FB-5-82	FC-5-60
-100KNAH	FA-80	FB-10-90	FC-20-80
-200KNAH	FA-100	FB-20-100	FC-20-100

** : -D in the parenthesis is a suffix code for two isolated I/O ports type load cell at option

LOAD CELLS

LOAD CELL FITTING ACCESSORY

Tension/Compression Universal Load Cells	Fitting accessory							
	Spherical Cap FA	Mounting Flange FB	Slide Support FC	Rotary Attach- ment FD	Rod End FE	Eye Bolt FF	Load Button FG	Shackle FH
TCLN-500NA ~ 2KNA	-	-	-	-	FE-002C/002D	-	-	-
-5KNA	-	-	-	-	FE-05C/05D	-	-	-
TCLB-50NA ~ 200NA	FA-20	FB-002-65	-	FD-002	FE-002A	-	FG-002	-
TCLA-500NB ~ 5KNB	-	-	-	FD-05B	FE-05A/-05B	-	-	-
TCLA-10KNB	-	-	-	FD-1B	FE-1A/-1B	-	-	-
TCLA-20KNB	-	-	-	FD-2B	FE-2A/-2B	-	-	-
TCLP-10KNB	FA-60	-	-	FD-1A	FE-1A	FF-1	FG-1	FH-1B
-20KNB (-D)**	FA-80	-	-	FD-2A	FE-2A	FF-2	FG-2	FH-2B
-30, -50KNB (-D)**	FA-100	-	-	FD-5	FE-5A	FF-5	FG-5	FH-5B
-100KNB (-D)**	FA-140	-	-	FD-10	FE-10A	FF-10	FG-10	FH-10B
-200KNB (-D)**	FA-140	-	-	FD-20	FE-20A	FF-20B	FG-20	FH-20B
TCLK-5KNA	FA-20	-	-	-	FE-05C	-	FG-05B	-
-10KNA	FA-60	-	-	-	FE-1A	-	FG-1	-
-20KNA	FA-80	-	-	-	FE-2A	-	FG-2	-
-50KNA	FA-100	-	-	-	FE-5A	-	FG-5	-
TCLZ-10NA ~ 200NA	FA-20	-	-	FD-002	FE-002A	-	FG-002	-
-500NA ~ 5KNA	FA-20	-	-	FD-05A	FE-05A	FF-1	FG-05	FH-1B
-10KNA	FA-20	-	-	FD-1A	FE-1A	FF-1	FG-05	FH-1B
TCLU-10KNA	FA-60	-	-	FD-1A	FE-1A	FF-1	FG-1	FH-1B
-20KNA	FA-80	-	-	FD-2A	FF-2A	FF-2	FG-2	FH-2B
-50KNA	FA-100	-	-	FD-5	FE-5A	FF-5	FG-5	FH-5B
-100KNA	FA-140	-	-	FD-10	FE-10A	FF-10	FG-10	FH-10B
-200KNA	FA-140	-	-	FD-20	FE-20A	FF-20B	FG-20	FH-20B
TCLM-10KNB	FA-60	FB-1M	-	FD-1A	FE-1A	FF-1	FG-1	FH-1B
-20KNB	FA-80	FB-2M	-	FD-2A	FE-2A	FF-2	FG-2	FH-2B
-50KNB	FA-100	FB-5M	-	FD-5	FE-5A	FF-5	FG-5	FH-5B
-100KNB	FA-140	FB-10M	-	FD-10	FE-10A	FF-10	FG-10	FH-10B
-200KNB	FA-140	FB-20M	-	FD-20	FE-20A	FF-20B	FG-20	FH-20B
Tension Load Cell	Spherical Cap FA	Mounting Flange FB	Slide Support FC	Rotary Attach- ment FD	Rod End FE	Eye Bolt FF	Load Button FG	Shackle FH
TLP-10KNB	-	-	-	-	-	-	-	FH-1B
-20KNB	-	-	-	-	-	-	-	FH-2B
-30KNB	-	-	-	-	-	-	-	FH-3B
-50KNB	-	-	-	-	-	-	-	FH-5B
-100KNB	-	-	-	-	-	-	-	FH-10B
-200KNB	-	-	-	-	-	-	-	FH-20B
-300KNB	-	-	-	-	-	-	-	FH-30B
-500KNB	-	-	-	-	-	-	-	FH-50B
-1MNB	-	-	-	-	-	-	-	FH-100B
TLJ-10KNA ~ 50KNA	-	-	-	-	FE-5C/-5D	-	-	-
-100KNA	-	-	-	-	FE-5A/-5B	-	-	-

** : -D in the parenthesis is a suffix code for two I/O ports type load cell at option

FA SPHERICAL CAP

The FA Spherical Cap is mounted to the top of a compression load cell for accurate transmission of compression loads.

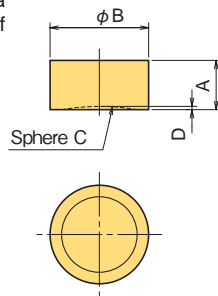

TYPE	A	φB	C	D	Weight
FA-20	15	38	20	2	0.15kg
FA-60	25	58	60	1	0.5kg
FA-80	25	58	80	1	0.5kg
FA-100	30	58	100	1.5	0.6kg
FA-140	40	78	140	3.5	1.5kg
FA-160	40	98	160	4	2.5kg
FA-250	45	128	250	5	4kg
FA-360	50	148	360	6	6kg
FA-360B	60	196	360	10	13kg
FA-720	110	280	720	10	54kg

FB-M MOUNTING FLANGE

The FB-M Mounting Flange is used to mount Rod End and Eye Bolt to TCLM-NB type load cell.

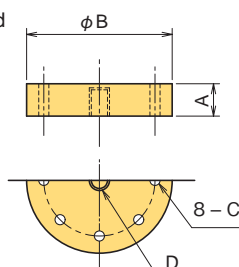

TYPE	A	φB	C	D	Weight
FB-1M	20	118	M8 PCD90	M12 x 1.75 DP15	1.5kg
FB-2M	25	118	M8 PCD90	M18 x 1.5 DP20	2kg
FB-5M	35	127	M8 PCD100	M24 x 2 DP30	3kg
FB-10M	50	187	M12 DP15 PCD150	M39 x 2 DP45	10kg
FB-20M	70	226	M16 DP25 PCD185	M50 x 2 DP60	21kg

FB MOUNTING FLANGE

The FB Mounting Flange is used when mounting area for a compression load cell is unstable or when load cell can not be secured from the bottom.

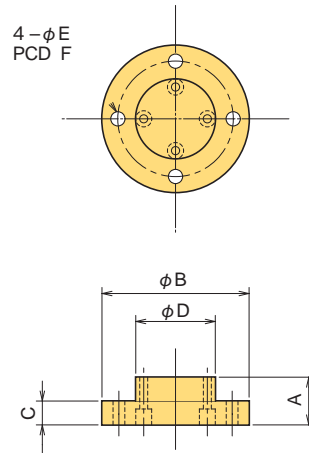

TYPE	A	φB	C	φD	φE	F	Weight
FB-2-44	20	98	10	54	9	76	0.7kg
FB-2-70	12	124	9	84	9	108	0.95kg
FB-5-54	25	138	10	92	11	114	2kg
FB-5-80	25	148	13	98	11	124	2.5kg
FB-5-82	20	150	14	102	11	130	2kg
FB-10-30	25	108	10	60	11	84	0.9kg
FB-10-60	30	158	10	108	11	134	3kg
FB-10-90	25	168	13	118	11	144	3kg
FB-20-40	30	118	10	70	11	94	1.5kg
FB-20-70	30	168	10	118	11	142	3kg
FB-20-100	30	178	15	127	11	158	4kg
FB-20-120	35	208	13	158	11	184	7kg
FB-50-60	40	138	15	90	11	114	3kg
FB-50-100	40	218	15	160	14	190	8kg
FB-50-150	40	248	15	187	14	220	11kg
FB-100-80	50	158	20	110	14	134	5kg
FB-100-104	50	228	20	170	14	200	11kg
FB-200-100	60	208	25	140	18	172	10kg
FB-300-120	60	228	25	160	18	192	13kg
FB-500-140	70	277	30	200	22	236	22kg
FB-1000-200	100	400	40	295	26	350	73kg

FC SLIDE SUPPORT

The FC Slide Support can be used to eliminate lateral load from compression load cell for high precision measurements.

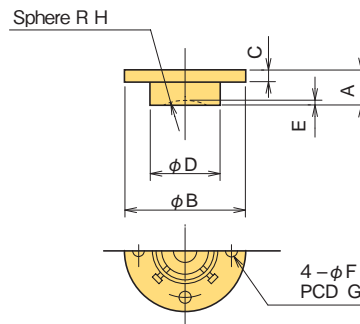

TYPE	A	φB	C	φD	E	φF	G	H	Sliding area	Weight
FC-2-20	27	98	10	56	2	9	76	20	±6mm	0.75kg
FC-5-60	40	128	13	84	1	11	106	60	±8mm	2kg
FC-20-80	45	168	13	118	1	11	140	80	±10mm	4kg
FC-20-100	45	168	13	118	1.5	11	140	100	±10mm	4kg
FC-50-140	55	218	18	164	3.5	13	190	140	±15mm	10kg

FD ROTARY ATTACHMENT

The FD Rotary Attachment ensures smooth load transmission by eliminating torsion during tension load measurements.

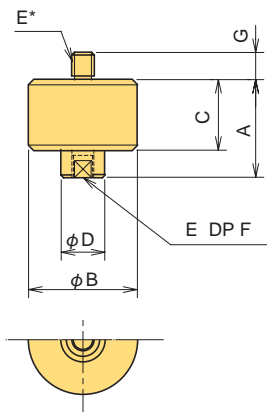

TYPE	A	φB	C	φD	E*	F	G	Weight
FD-002	54	58	39	20	M 6x1	12	7	0.8kg
FD-05A	54	58	39	20	M12x1.75	15	13	0.8kg
FD-05B	54	58	39	20	M12x1.75	15	15	0.8kg
FD-1A	54	88	39	20	M12x1.75	15	13	2kg
FD-1B	54	88	39	20	M12x1.75	15	15	2kg
FD-2A	67	100	50	26	M18x1.5	20	18	3kg
FD-2B	67	100	50	26	M18x1.5	20	20	3kg
FD-5	87	100	71	32	M24x2	30	28	4kg
FD-10	112	138	93	50	M39x2	45	43	11kg
FD-20	150	176	122	65	M50x2	65	60	23kg

E* :FD-05B M12xP1.75 DP15 internal thread
 FD-1B M12xP1.75 DP15 internal thread
 FD-2B M18xP1.5 DP20 internal thread

LOAD CELLS

LOAD CELL FITTING ACCESSORY

FE ROD END

The FE Rod End is ideal when a tension/compression universal load cell is used to measure tension loads on machinery and structures.

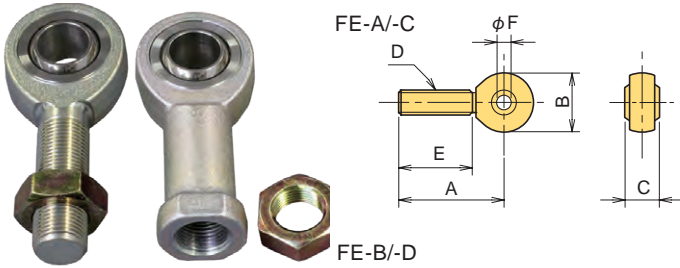

Please note that a combination use is not available with the FH Shackle below.

TYPE	A	B	C	D	E	φF	Weight
FE-002A	36	18	9	M 6x1	22	6	0.02kg
FE-002C	39.5	20.5	11	M 5x0.8	22	5	0.035kg
FE-002D	35	20.5	11	M 5x0.8	19	5	0.04kg
FE-05A	54	30	16	M12x1.75	33	12	0.1kg
FE-05B	50	30	16	M12x1.75	24	12	0.1kg
FE-05C	46	23	11	M 8x1.25	29	8	0.04kg
FE-05D	41	23	11	M 8x1.25	22	8	0.05kg
FE-1A	62	34	16	M12x1.75	37	12	0.15kg
FE-1B	57	34	16	M12x1.75	32	12	0.15kg
FE-2A	79.5	43	20	M18x1.5	46	18	0.3kg
FE-2B	74	43	20	M18x1.5	40	18	0.3kg
FE-5A	105	70	35	M24x2	59	25	1kg
FE-5B	105	70	35	M24x2	54	25	1.2kg
FE-5C	83	45	22	M20x1.5	50	20	0.3kg
FE-5D	76	45	22	M20x1.5	41	20	0.33kg
FE-10A	173	100	43	M39x2	80	40	4kg
FE-20A	231	120	53	M50x2	105	50	7kg

FF EYE BOLT

The FF Eye Bolt is used when a tension/compression universal load cell is used to measure tension. It can be used with FH Shackle.

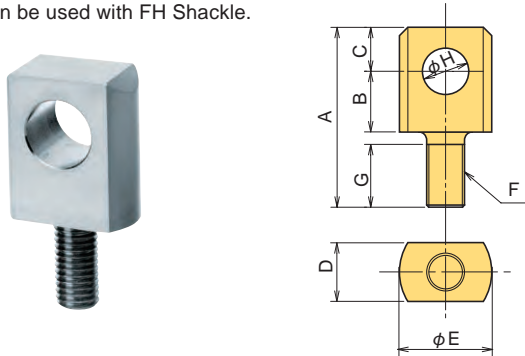

TYPE	A	B	C	D	φE	F	G	φH	Weight
FF-1	65	25	15	22	35	M12x1.75	21	18	0.2kg
FF-2	86	30	21	27	45	M18x1.5	30	22	0.5kg
FF-5	128	45	33	43	70	M24x2	44	37	1.5kg
FF-10	166	55	46	58	95	M39x2	57	49	4kg
FF-20B	207	53	57	68	100	M50x2	85	54	6kg

FG LOAD BUTTON

The FG Load Button is used when a tension/compression universal load cell is used to measure compression.

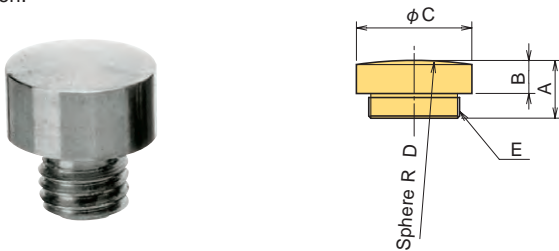

TYPE	A	B	φC	D	E	Weight
FG-002	10	6	9	20	M 6x1	4g
FG-05B	15	8	14	20	M 8x1.25	12g
FG-05	18	10	16	20	M12x1.75	20g
FG-1	20	10	20	60	M12x1.75	30g
FG-2	20	10	26	80	M18x1.5	55g
FG-5	22	12	32	100	M24x2	100g
FG-10	25	15	50	140	M39x2	300g
FG-20	30	20	64	140	M50x2	600g

FH SHACKLE

The FH Shackle is used with a tension load cell in instances such as measuring wire tension.

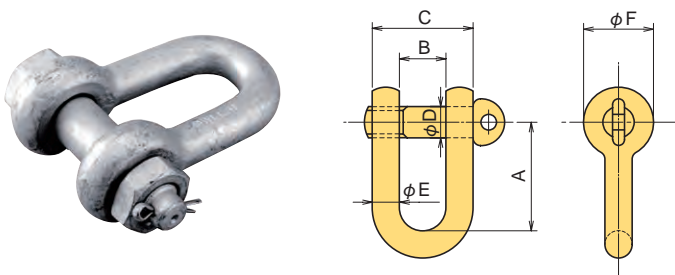

TYPE	A	B	C	φD	φE	φF	Weight
FH-1B	56	24	52	17	14	36	0.4kg
FH-2B	72	29	65	21	18	45	0.85kg
FH-3B	88	34	78	26	22	55	1.5kg
FH-5B	120	45	105	36	20	75	5kg
FH-10B	160	60	140	48	40	100	11kg
FH-20B	171	73	165	50	46	110	13kg
FH-30B	201	83	183	58	50	127	20kg
FH-50B	239	105	236	70	65	153	40kg
FH-100B	314	134	314	96	90	203	100kg

DISPLACEMENT TRANSDUCERS

TML displacement transducers are used to measure various types of displacement such as displacement in structures and machinery as well as elongation and cracks in materials testing. They are widely used in applications ranging from testing and research to control. We offer a wide spectrum of displacement transducers to fit any type of measuring item, mounting location or displacement, and our products can easily be combined with Data Loggers or other equipment for automatic measurement of multiple points.

OUTPUT POLARITY WITH A LOAD

The measured value changes in positive (+) direction when the distance between the displacement transducer and the contact point increases or when the distance between two contact points increases (for crack measurement).

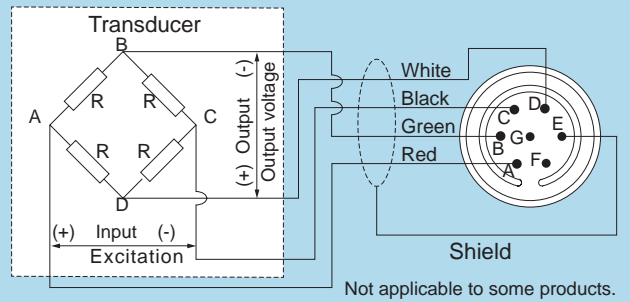

Displacement transducer selection

Application	TYPE	Capacity (mm)													Page	
		2	5	10	20	25	30	50	100	200	300	500	1000	2000		5000
High sensitivity	CDP		●	●		●		●	●							40
	CDP-M-MT		●	●		●		●	●							41
Drip-proof structure	CDP-B		●	●		●										42
High sensitivity, Two-isolated I/O ports type	CDP-D							●	●							42
High sensitivity, Tension use	CDP-T					●										43
General, Ruler built-in	SDP-E							●	●	●	●					44
Tension use, Ruler built-in	SDP-ET							●	●							45
Dial gauge type	DDP-A			●	●		●	●								45
Tape measure type	DP-E														●	46
	DP-G										●	●	●			46
Waterproofing structure	FDP-A			●		●		●	●							47
Large span	PI	●	●													48
Ring type	OU			●	●			●								49
Simplest construction	CE	●	●	●												49
Simple design, COD (Crack opening displacement) measurement	RA	●	●													50
	RA-L	●	●													50
	UB	●	●													50
	UB-A		●													50
Displacement transducers accessory		Contact tips, Hook bolt, Holder, Magnet stand, Fixing jigs, etc.													51	
Extensometer	EDP-A/-B		●													52

EXAMPLE OF DISPLACEMENT TRANSDUCER USE

General displacement measurements

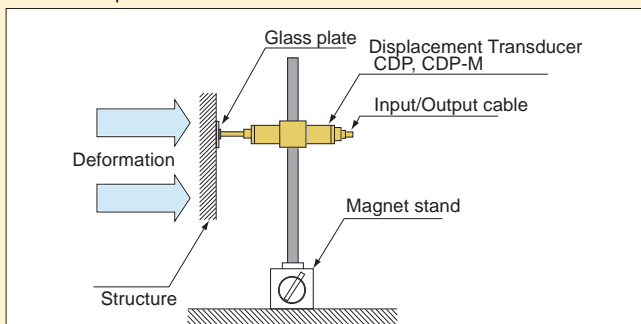

This configuration is used to measure structural deformation and movement.

Measuring cracks in concrete

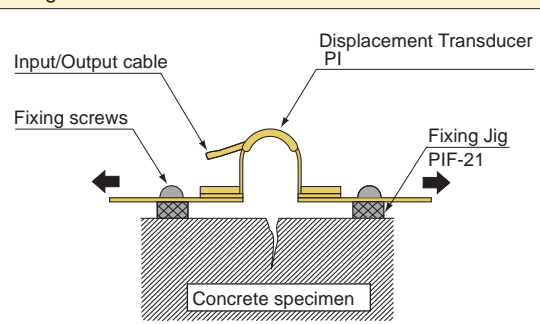

This configuration is used to measure opening displacement due to cracks propagating in concrete.

Measuring girder bend

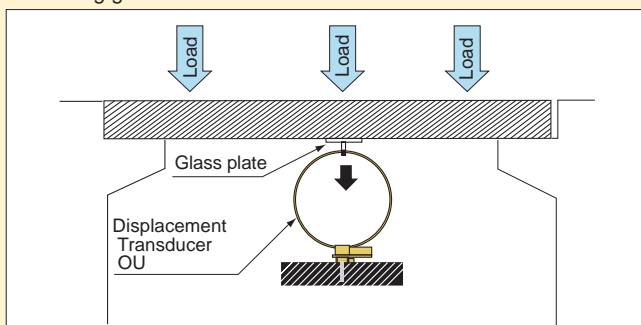

This configuration is used to measure bend with a load applied to a bridge girder.

Measuring displacement and bending strains

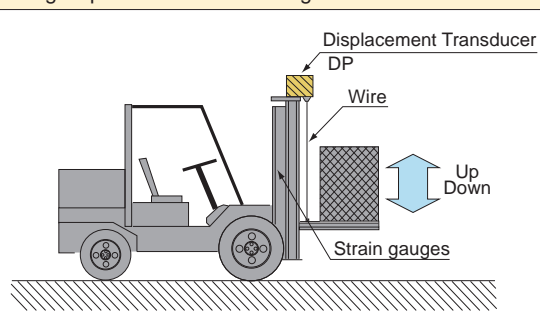

This configuration is used to measure displacement and bending strains in fork-lift truck onboard measurement.

DISPLACEMENT TRANSDUCERS

CDP Displacement Transducer

5~100mm

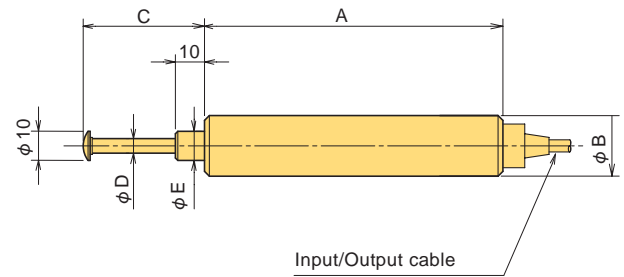

■ DIMENSIONS

TYPE	A	φB	C	φD	φE
CDP-5	99	20.5	20	5	10
CDP-10	99	20.5	24	5	10
CDP-25	114	20.5	40	5	10
CDP-50	154	33.5	65	5	10
CDP-100	274	41	118	6	12

The CDP displacement transducer is a compact, easy-to-operate strain gauge type transducer. Because it is designed to produce a large output and to deliver stable performance, highly accurate measurements can be made. It is suitable for both static and dynamic measurements.

Protection ratings: IP40 equivalent

High precision

HOLDER CDPF-11

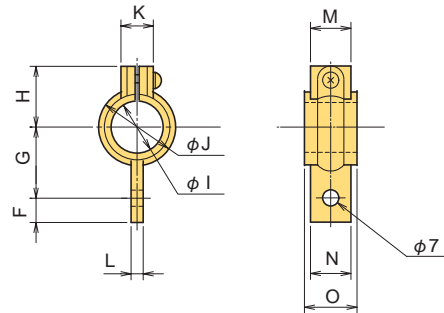

■ DIMENSIONS HOLDER

TYPE	Applicable CDP	F	G	H	φI	φJ	K	L	M	N	O
CDPF-11-25	CDP-5~25	10	28	25	20.5	30	13	5	15	15	20
CDPF-11-50	CDP-50	10	35	32	33.5	43	13	5	15	15	20
CDPF-11-100	CDP-100	11	36	40	41	50	17.5	8	14	16	25

■ SPECIFICATIONS

TYPE	CDP-5	CDP-10	CDP-25	CDP-50	CDP-100
Capacity	5mm	10mm	25mm	50mm	100mm
Rated Output	5mV/V(10000×10 ⁻⁶ strain) ±0.15%	5mV/V(10000×10 ⁻⁶ strain) ±0.1%	6.25mV/V(12500×10 ⁻⁶ strain) ±0.1%	5mV/V (10000×10 ⁻⁶ strain) ±0.1%	
Sensitivity(x10 ⁻⁶ strain)/mm	2000	1000	500	200	100
Non-linearity	0.15%RO	0.1%RO			
Spring force	6.4N	3.4N			4.9N
Frequency response	40Hz	12Hz	8Hz	6Hz	3Hz
Temperature effect on zero	0.01%RO/°C		0.008%RO/°C		0.01%RO/°C
Compensated temperature range	0 ~ +40°C (no condensation)				
Allowable temperature range	-10 ~ +60°C (no condensation)				
Input/Output resistance	350Ω				
Recommended exciting voltage	2V or less				
Allowable exciting voltage	10V				
Holders supplied	CDPF-11-25 1 piece			CDPF-11-50 2 pieces	CDPF-11-100 2 pieces
Weight	90g	90g	100g	270g	580g

Supplied cable : CT6-4V10/NJ-STB (φ6mm 0.3mm² 4-core shielded vinyl cable 10m)

DISPLACEMENT TRANSDUCERS

CDP-M Small Displacement Transducer 5~100mm

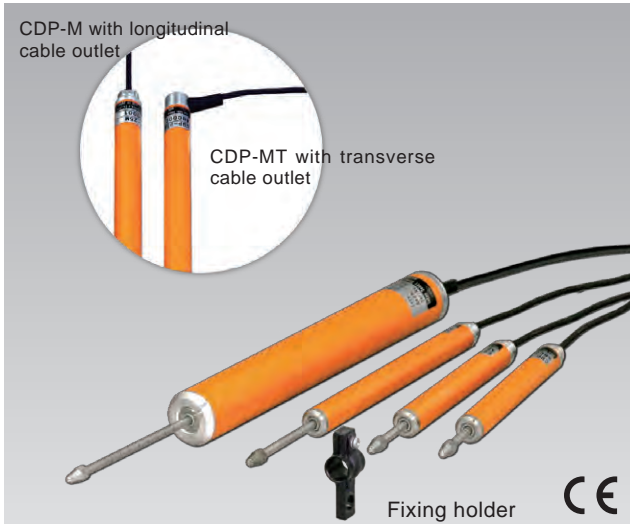

The CDP-M series is a small and high sensitivity displacement transducer. Compared with conventional CDP series, its output is the same but the CDP-M is smaller by 50~80% in diameter and its temperature range extended up to +80°C. This series is available with CDP-M with cable output along the measurement axis and CDP-MT with cable output vertical to the axis. The transducer can be used for not only static measurements but quasi-dynamic measurements. A fixing holder is supplied as a standard accessory. Options include ordinary magnet stand MB-B and small MB-PSL specified for the CDP-M series.

Protection ratings: IP40 equivalent

Small size

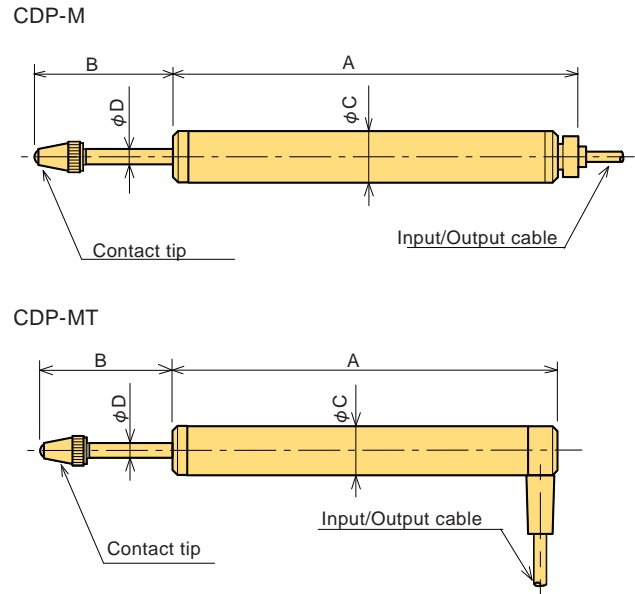

■ DIMENSIONS

TYPE	A	B	φC	φD	Holder
CDP-5M /-5MT	79	21.5	10	3	CDPF-12-25
CDP-10M /-10MT	79	27			
CDP-25M /-25MT	114.5	41.5	20	5	CDPF-11-25
CDP-50M /-50MT	158	68			
CDP-100M /-100MT	268	115	33	5	CDPF-11-50

HOLDER

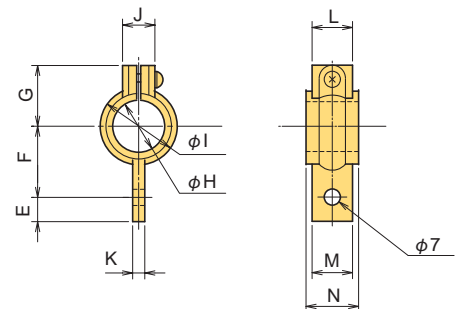

■ DIMENSIONS HOLDER

TYPE	E	F	G	φH	φI	J	K	L	M	N
CDPF-12-25	7	17.5	16.5	10.4	15	9	5	10	10	15
CDPF-11-25	10	28	25	20.5	30	13	5	15	15	20
CDPF-11-50	10	35	32	33.5	43	13	5	15	15	20

■ SPECIFICATIONS

TYPE	CDP-5M CDP-5MT	CDP-10M CDP-10MT	CDP-25M CDP-25MT	CDP-50M CDP-50MT	CDP-100M CDP-100MT
Capacity	5mm	10mm	25mm	50mm	100mm
Rated Output	5mV/V(10000×10 ⁻⁶ strain) ±0.3%		6.25mV/V(12500×10 ⁻⁶ strain) ±0.3%	5mV/V (10000×10 ⁻⁶ strain) ±0.3%	
Sensitivity(x10 ⁻⁶ strain)/mm	2000	1000	500	200	100
Non-linearity	0.3%RO				
Spring force	2N	1.3N	1.5N	1.2N	5N
Frequency response	13Hz	6.5Hz	7Hz	10Hz	9.5Hz
Temperature effect on zero	0.05%RO/°C				
Compensated temperature range	0 ~ +40°C (no condensation)				
Allowable temperature range	-10 ~ +80°C (no condensation)				
Input/Output resistance	350Ω				
Recommended exciting voltage	2V or less				
Allowable exciting voltage	10V				
Holders supplied	CDPF-12-25 1 piece			CDPF-11-25 2 pieces	CDPF-11-50 2 pieces
Weight	29g		46g	120g	350g

Supplied cable : CT6-4V10/NJ-STB (φ 6mm 0.3mm² 4-core shielded vinyl cable 10m)

DISPLACEMENT TRANSDUCERS

CDP-B Displacement Transducer 5~25mm

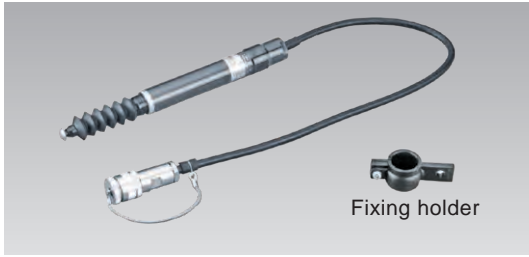

The CDP-B displacement transducer is the CDP displacement transducer with a bellows attached to the measuring rod. It is used if measurement must be made in an adverse on-site environment.

Protection ratings: IP42 equivalent

On-site application

■ SPECIFICATIONS

TYPE	CDP-5B	CDP-10B	CDP-25B
Capacity	5mm	10mm	25mm
Rated Output	5mV/V(10000×10 ⁻⁶ strain) ±0.1%		
Sensitivity(x10 ⁻⁶ strain)/mm	2000	1000	500
Non-linearity	0.15%RO	0.1%RO	
Spring force	6.4N	3.4N	
Frequency response	40Hz	12Hz	5Hz
Temperature effect on zero	0.01%RO/°C		
Compensated temperature range	0 ~ +40°C (no condensation)		
Allowable temperature range	-10 ~ +60°C (no condensation)		
Input/Output resistance	350Ω		
Recommended exciting voltage	2V or less		
Allowable exciting voltage	10V		
Holders supplied	CDPF-11-25 1 piece		
Weight	130g	130g	140g

Supplied cable :CT6-4N10/WJ-STB (φ 6mm 0.35mm² 4- core shielded chloro-prene cable 10m)

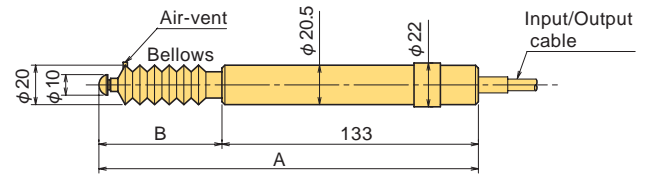

HOLDER CDPF-11-25

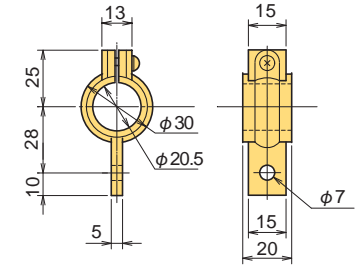

■ DIMENSIONS

TYPE	A	B
CDP-5B	197	64
CDP-10B	198	65
CDP-25B	208	75

CDP-D Displacement Transducer 50/100mm



The CDP-D displacement transducer is the CDP displacement transducer with dual isolated I/O ports. For example, one set of input and output cables can be connected to an analog measuring instrument and the other set to a digital measuring instrument. With two different types of measuring equipment connected to this transducer, simultaneous measurements can be made without interference.

■ SPECIFICATIONS

TYPE	CDP-50-D	CDP-100-D
Capacity	50mm	100mm
Rated Output	5mV/V(10000×10 ⁻⁶ strain) ±0.1%	
Sensitivity(x10 ⁻⁶ strain)/mm	200	100
Non-linearity	0.1%RO	
Cross sensitivity	0.2%RO	
Spring force	3.4N	4.9N
Frequency response	6Hz	3Hz
Temperature effect on zero	0.01%RO/°C	
Compensated temperature range	0 ~ +40°C (no condensation)	
Allowable temperature range	-10 ~ +60°C (no condensation)	
Input/Output resistance	350Ω	
Recommended exciting voltage	2V or less	
Allowable exciting voltage	10V	
Holders supplied	CDPF-11-50 2 pcs.	CDPF-11-100 2 pcs.
Weight	300g	600g

Supplied cable : CT6-4V10/NJ-STB (φ 6mm 0.3mm² 4-core shielded vinyl cable 10m)

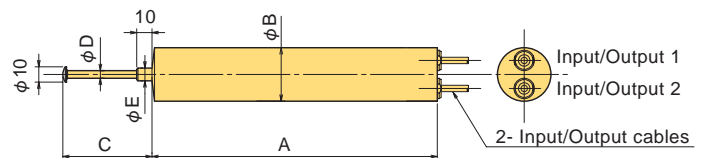

■ DIMENSIONS

TYPE	A	φB	C	φD	φE
CDP-50-D	165	33.5	65	5	10
CDP-100-D	274	41	118	6	12

Protection ratings: IP40 equivalent

HOLDER CDPF-11

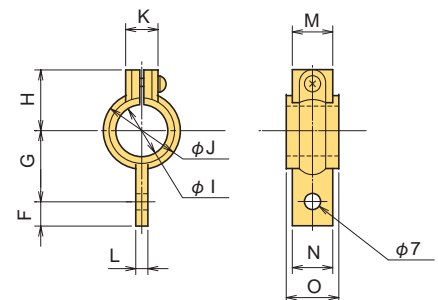

■ DIMENSIONS HOLDER

TYPE	Applicable CDP	F	G	H	φI	φJ	K	L	M	N	O
CDPF-11-50	CDP-50-D	10	35	32	33.5	43	13	5	15	15	20
CDPF-11-100	CDP-100-D	11	36	40	41	50	17.5	8	14	16	25

DISPLACEMENT TRANSDUCERS

CDP-T Displacement Transducer

25mm

NEW



Wire tension High precision

The CDP-T displacement transducer is the Tensile-type CDP displacement transducer. Use the hook on the measuring axis of the main unit to measure the displacement via a wire or other means.

Because it is designed to produce a large output and to deliver stable performance, highly accurate measurements can be made. (Please take into account the loss of sensitivity due to stretching of wires, etc. before use.)

Protection ratings: IP40 equivalent

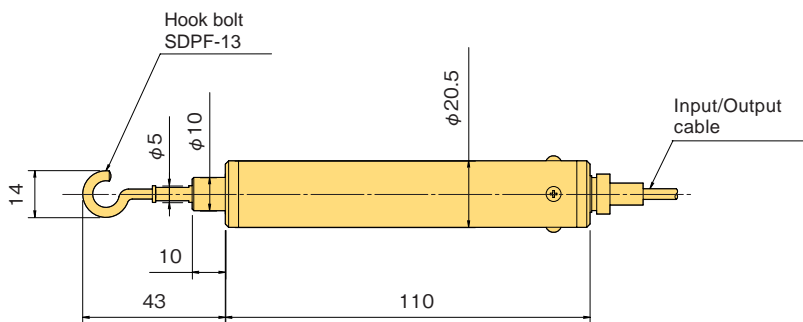

HOLDER CDPF-11-25

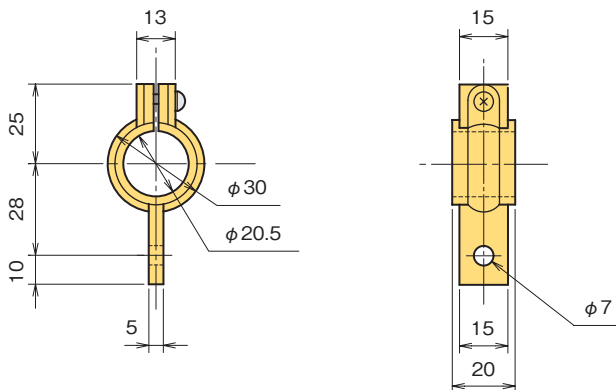

■ SPECIFICATIONS

TYPE	CDP-25T
Capacity	25mm
Rated Output	6.25mV/V(12500×10 ⁻⁶ strain) ±0.15%
Sensitivity(x10 ⁻⁶ strain)/mm	500
Non-linearity	0.15%RO
Spring force	3.4N
Frequency response	8Hz
Temperature effect on zero	0.015%RO/°C
Compensated temperature range	0 ~ +40°C (no condensation)
Allowable temperature range	-10 ~ +60°C (no condensation)
Input/Output resistance	350Ω
Recommended exciting voltage	2V or less
Allowable exciting voltage	10V
Holders supplied	CDPF-11-25 1 pcs.
Weight	115g

Supplied cable : CT6-4V10/NJ-STB (φ6mm 0.3mm² 4-core shielded vinyl cable 10m)

DISPLACEMENT TRANSDUCERS

SDP-E Displacement Transducer

50 / 100 / 200 / 300mm

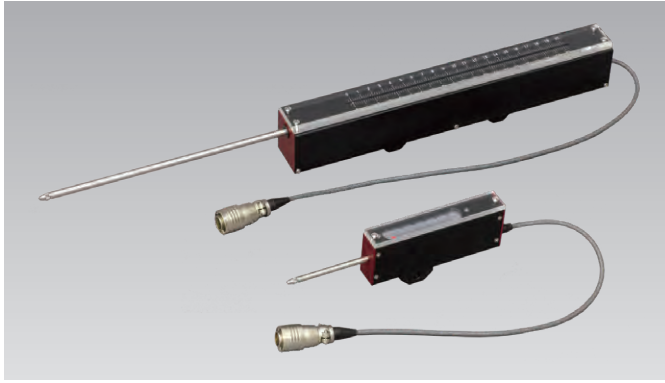

General purpose

This is a strain gauge type displacement transducer for general purpose. This transducer has a small cantilever inside, and displacement is mechanically converted into deflection of the cantilever. Strain, which is proportional to the deflection, is generated on the cantilever and is measured by strain gauges. Stable measurement is possible even for a small displacement. The scale and pointer on the main body enables easy positioning of the transducer.

For SDP-200E and SDP-300E, a dual-output type with two independent input/output ports is optionally available.

Protection ratings: IP40 equivalent

SDP-50E/SDP-100E

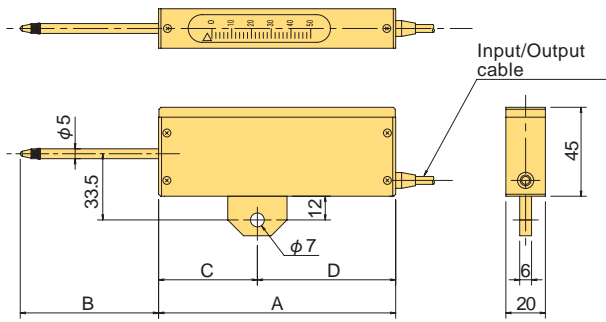

■ DIMENSIONS

TYPE	A	B	C	D
SDP-50E	120	70	50	70
SDP-100E	210	120	90	120

SDP-200E/SDP-300E

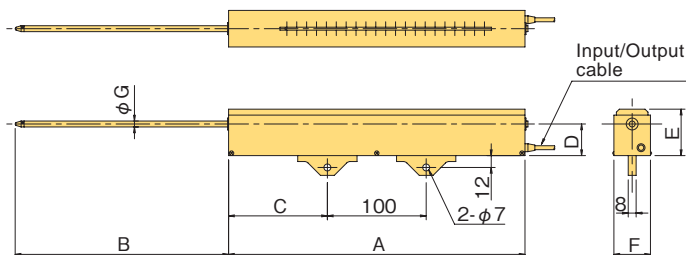

■ DIMENSIONS

TYPE	A	B	C	D	E	F	G
SDP-200E	300	216	100	32	47	37	6
SDP-300E	400	317	150	35	51	42	8

■ SPECIFICATIONS

TYPE	SDP-50E	SDP-100E	SDP-200E	SDP-300E
Capacity	50mm	100mm	200mm	300mm
Rated Output	2.5mV/V(5000×10 ⁻⁶ strain) ±0.2%		5mV/V(10000×10 ⁻⁶ strain) ±0.3%	
Sensitivity(x10 ⁻⁶ strain)/mm	100	50	50	33
Non-linearity	0.2%RO		0.3%RO	
Spring force	6N			7.4N
Frequency response	1Hz		2Hz	
Allowable temperature range	-10 ~ +60°C (no condensation)			
Input/Output resistance	350Ω			
Recommended exciting voltage	2V or less			
Allowable exciting voltage	5V		10V	
Weight	220g	320g	900g	1200g

Supplied cable : CT6-4V10/NJ-STB (φ 6mm 0.3mm² 4-core shielded vinyl cable 10m)

DISPLACEMENT TRANSDUCERS

SDP-ET Displacement Transducer 50/100mm

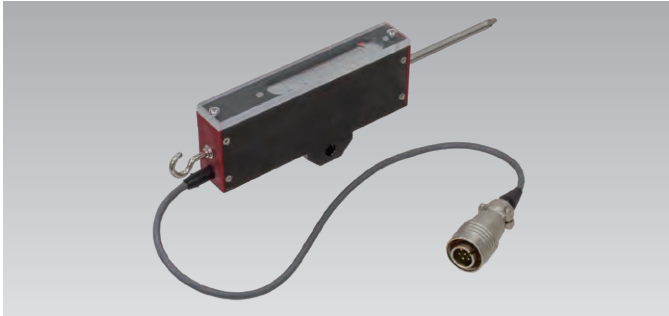

Wire tension
General purpose

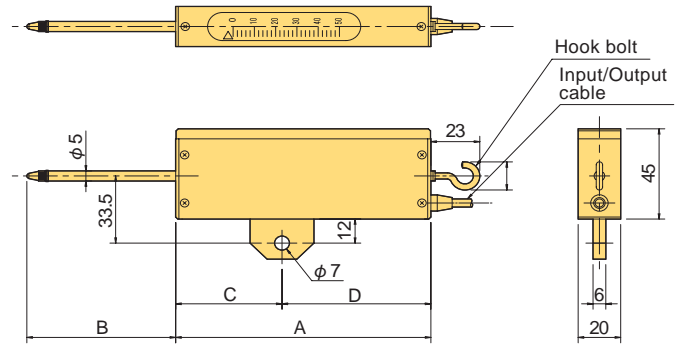

The SDP-ET displacement transducer is a general-purpose, strain gauge type transducer, and features measurement of tension displacement using hook bolt. Designed with a strain-generating cantilever, it is able to make stable measurement while maintaining the high sensitivity to minuscule displacements.

Protection ratings: IP40 equivalent

SPECIFICATIONS

TYPE	SDP-50ET	SDP-100ET
Capacity	50mm	100mm
Rated Output	2.5mV/V(5000×10 ⁻⁶ strain) ±0.2%	
Sensitivity(x10 ⁻⁶ strain)/mm	100	50
Non-linearity	0.2%RO	
Spring force	6N	
Frequency response	1Hz	
Allowable temperature range	-10 ~ +60°C (no condensation)	
Input/Output resistance	350Ω	
Recommended exciting voltage	2V or less	
Allowable exciting voltage	5V	
Weight	220g	320g

Supplied cable : CT6-4V10/NJ-STB (φ6mm 0.3mm² 4-core shielded vinyl cable 10m)

DIMENSIONS

TYPE	A	B	C	D
SDP-50ET	120	70	50	70
SDP-100ET	210	120	90	130

DDP-A Displacement Transducer 10~50mm



DDP-10--30A

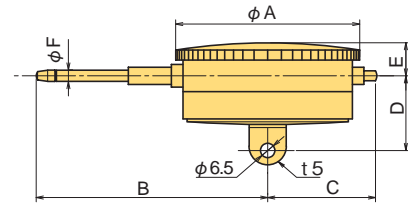

DDP-50A

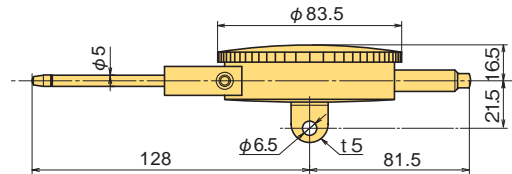

The DDP-A displacement transducer is a dial gauge with a strain sensing element and a bridge circuit integrated. The amount of displacement can be checked by viewing the pointer while the output from the sensing element can be used to control a recorder or a machine.

Protection ratings: IP40 equivalent

Dial gauge Integrated

SPECIFICATIONS

TYPE	DDP-10A	DDP-20A	DDP-30A	DDP-50A
Capacity	10mm	20mm	30mm	50mm
Rated Output	1.5mV/V(3000×10 ⁻⁶ strain) ±0.3%			2.5mV/V(5000×10 ⁻⁶ strain) ±0.3%
Sensitivity(x10 ⁻⁶ strain)/mm	300	150	100	
Non-linearity	0.3%RO			
Spring force	2.9N	3.9N		5.4N
Frequency response	2Hz		1Hz	
Allowable temperature range	-10 ~ +60°C (no condensation)			
Input/Output resistance	350Ω			
Recommended exciting voltage	2V or less			
Allowable exciting voltage	5V			
Weight	190g	340g	400g	500g

Supplied cable : CT6-4V10/NJ-STB (φ6mm 0.3mm² 4-core shielded vinyl cable 10m)

DIMENSIONS

TYPE	φA	B	C	D	E	φF
DDP-10A	53	65	40.5	33	14.5	4
DDP-20A	66.5	90	41	33	14.5	5
DDP-30A	76	102	46	33	15	5
DDP-50A	As per the figure					

DISPLACEMENT TRANSDUCERS

DP-G / E Displacement Transducer 500~5000mm

NEW



Wire tension type

The DP-G / E displacement transducer is used to measure a large amount of displacement. A stainless steel wire is drawn to measure displacement. The wire tension is constant in the same direction regardless of the amount of displacement. This is a small, lightweight, and high-accuracy transducer.

Protection ratings: IP 40 equivalent



(for DP-G only)

DP-500G/-1000G/-2000G

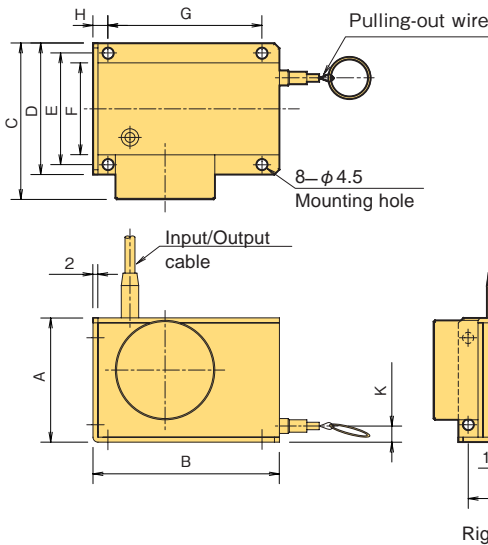

DP-5000E

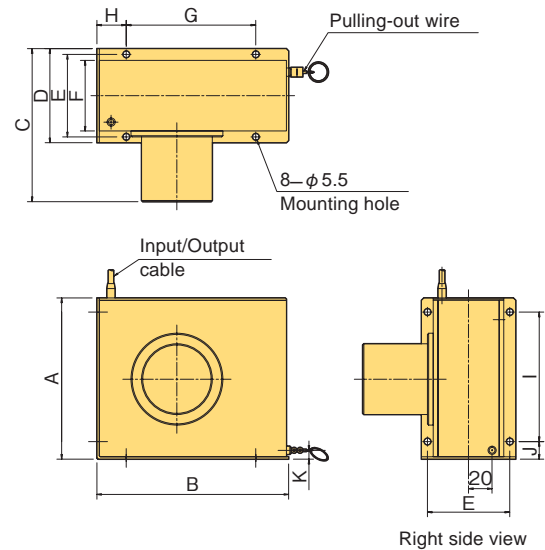

■ DIMENSIONS

TYPE	A	B	C	D	E	F	G	H	I	J	K
DP-500G	50	75	63	53	45	37	62	6	35	7	6.5
DP-1000G	50	75	63	53	45	37	62	6	35	7	6.5
DP-2000G	80	98	67	57	49	41	74	16	53	19	6.5
DP-5000E	137	163	130	80	70	60	110	25	110	15	7.5

■ SPECIFICATIONS

TYPE	DP-500G	DP-1000G	DP-2000G	DP-5000E
Capacity	500mm	1000mm	2000mm	5000mm
Rated Output	5mV/V(10000×10 ⁻⁶ strain) ±0.3%			
Sensitivity(x10 ⁻⁶ strain)/mm	20	10	5	2
Non-linearity	0.3%RO			
Spring force	1.5N		1.7N	2N
Allowable temperature range	-10 ~ +80°C (no condensation)			
Input/Output resistance	Input 260Ω Output 350Ω		Input 200Ω Output 350Ω	
Recommended exciting voltage	2V or less			
Allowable exciting voltage	10V			
Weight	230g	230g	400g	1400g

Supplied cable : CT6-4V10/NJ-STB (φ 6mm 0.3mm² 4-coreshielded vinyl cable 10m)

DISPLACEMENT TRANSDUCERS

FDP-A Waterproof Displacement Transducer 10~100mm

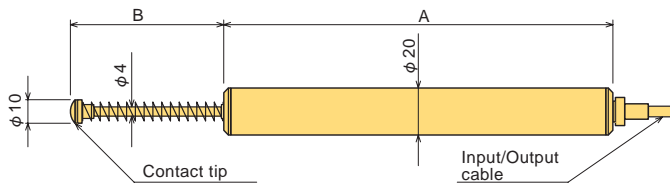
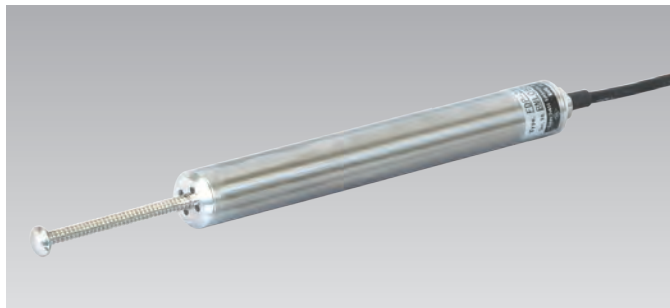

■ DIMENSIONS

TYPE	A	B
FDP-10A	170	69
FDP-25A	170	69
FDP-50A	230	89
FDP-100A	347	181

FDP-A series is a DC operated LVDT which can be measured with not only our TDS series data loggers but DC excitation type dynamic strainmeters and handheld strainmeters. In addition to high output and high response, waterproof structure and all stainless steel made external parts make underwater measurement possible.

Protection ratings: IP68 equivalent

Waterproof type

■ Instruments

Data Logger



■ Sensor mode applicable: Full bridge 0-2V

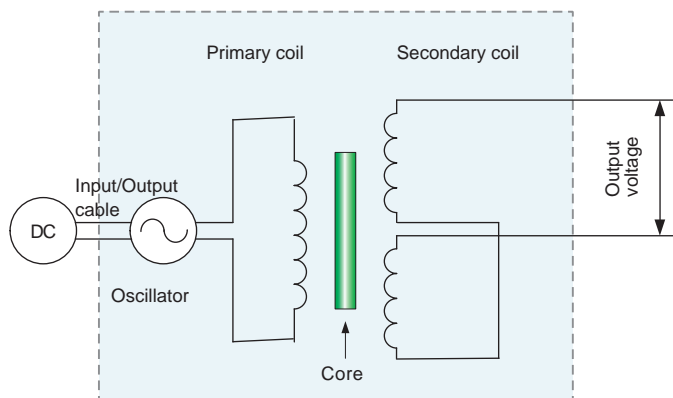

Handheld Data Logger



Dynamic strain recorder



■ SPECIFICATIONS

TYPE	FDP-10A	FDP-25A	FDP-50A	FDP-100A
Capacity	10mm	25mm	50mm	100mm
Rated Output	10000x10 ⁻⁶ strain		15000x10 ⁻⁶ strain	
Sensitivity(x10 ⁻⁶ strain)/mm	1000	600	300	150
Non-linearity	0.5%RO			
Spring force	3N		3.5N	
Frequency response	16Hz	10Hz	8Hz	5Hz
Temperature effect on zero	0.05%RO/°C			
Compensated temperature range	-10 ~ +60°C (no icing)			
Allowable temperature range	-10 ~ +80°C (no icing)			
Recommended exciting voltage	2V or less			
Allowable exciting voltage	5V			
Water pressure resistance	1MPa			
Holders supplied	CDPF-11-25 1 pc.		CDPF-11-25 2 pcs.	
Weight	250g	250g	350g	650g

Input/Output cable : φ 4.6mm 0.14mm² 4-core shielded vinyl cable 10m

DISPLACEMENT TRANSDUCERS

PI Displacement Transducer $\pm 2/\pm 5\text{mm}$

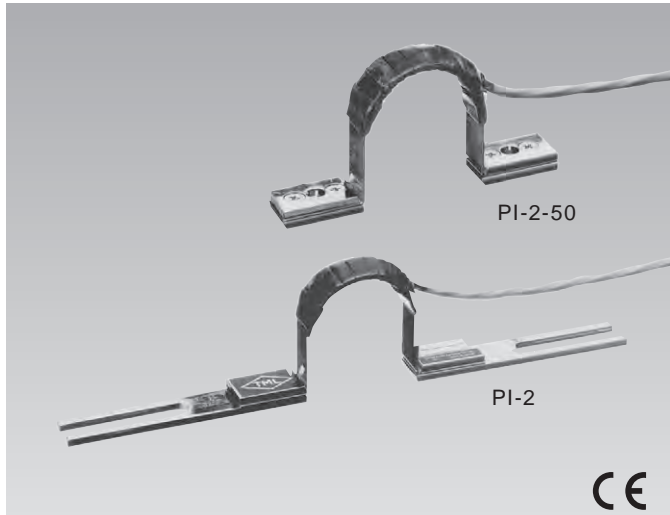

The PI displacement transducer has a simple structure: a combination of strain gauges and an arch-shaped spring plate, the former attached to the latter. Six models designed for gauge lengths of 50 mm to 300 mm are available. This transducer is used to measure the crack opening displacement occurring within each gauge length on the surface of concrete or to measure the displacement of various structures.

Pi-shape type Surface measurement use

PI-2-50/PI-5-50

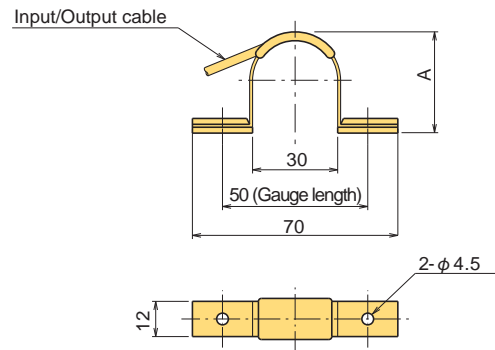

PI-2/PI-5

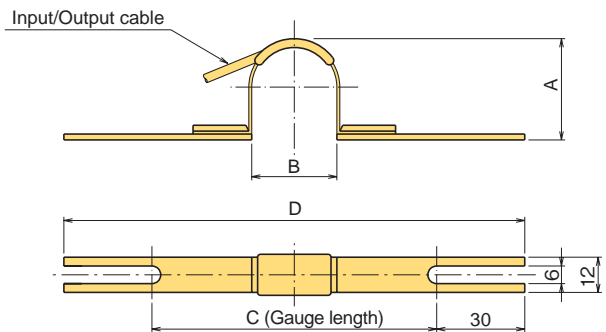

■ DIMENSIONS

TYPE	A	B	C	D	Weight
PI-2-50	35	As per the figure			40
PI-2-100	35	30	100	160	50
PI-2-150	35	30	150	210	60
PI-2-200	35	30	200	260	70
PI-2-250	35	30	250	310	80
PI-2-300	35	30	300	360	90
PI-5-50	50	As per the figure			40
PI-5-100	45	40	100	160	50
PI-5-150	45	40	150	210	60
PI-5-200	45	40	200	260	70
PI-5-250	45	40	250	310	80
PI-5-300	45	40	300	360	90

■ ACCESSORY

TYPE	Dummy plate	Fixing jig
PI-2-50 / PI-5-50	PIF-11-50	PIF-21-50
PI-2-100 / PI-5-100	PIF-11-100	PIF-21-100
PI-2-150 / PI-5-150	PIF-11-150	PIF-21-100
PI-2-200 / PI-5-200	PIF-11-200	PIF-21-100
PI-2-250 / PI-5-250	PIF-11-250	PIF-21-100
PI-2-300 / PI-5-300	PIF-11-300	PIF-21-100

Dummy plate PIF-11

This plate is used to maintain the proper gauge length when mounting the PIF-21 jig to test specimen.

Fixing Jig PIF-21

This Jig is pre-mounted to concrete and other test specimen in order to screw-mount PI displacement transducer.

■ SPECIFICATIONS

TYPE	PI-2	PI-5
Gauge length	50, 100, 150, 200, 250, 300 mm	
Capacity	$\pm 2\text{mm}$	$\pm 5\text{mm}$
Rated Output	2mV/V(4000 $\times 10^{-6}$ strain)	2.5mV/V(5000 $\times 10^{-6}$ strain)
Sensitivity(x10 ⁻⁶ strain)/mm	2000	1000
Non-linearity	0.5%RO	
Allowable temperature range	0 ~ +40°C	
Input/Output resistance	350 Ω	
Recommended exciting voltage	2V or less	
Allowable exciting voltage	10V	

Input/Output cable : $\phi 3\text{mm}$ 0.09mm² 4-core vinyl cable 2m

DISPLACEMENT TRANSDUCERS

OU Ring type Displacement Transducer 10~30mm

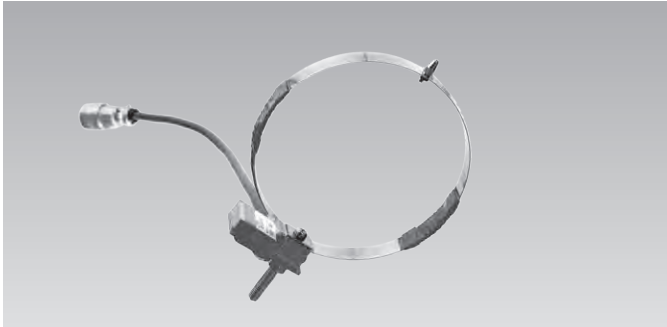

The OU displacement transducer is a combination of a round plate spring and strain gauges. It is mounted with its contact tip pressed against a structure. When displacement occurs in the structure, the plate spring is deformed and the amount of output proportional to the amount of displacement can be output.

Ring type

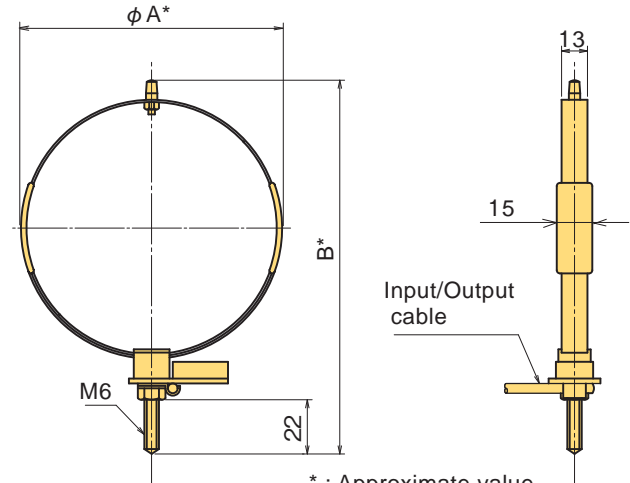

* : Approximate value

■ SPECIFICATIONS

TYPE	OU-10	OU-20	OU-30
Capacity	10mm	20mm	30mm
Rated Output	5mV/V(10000×10 ⁻⁶ strain)		
Sensitivity(x10 ⁻⁶ strain)/mm	1000	500	300
Non-linearity	1%RO		
Spring force	31N	25N	17N
Frequency response	55Hz	30Hz	20Hz
Allowable temperature range	0 ~ +40°C		
Input/Output resistance	350Ω		
Recommended exciting voltage	2V or less		
Allowable exciting voltage	10V		
Weight	60g	70g	75g

Supplied cable : CT6-4V5/NJ-STB (φ6mm 0.3mm² 4-core shielded vinyl cable 5m)

■ DIMENSIONS

TYPE	φA	B
OU-10	85	130
OU-20	115	160
OU-30	155	200

CE Cantilever type Displacement Transducer 2~10mm

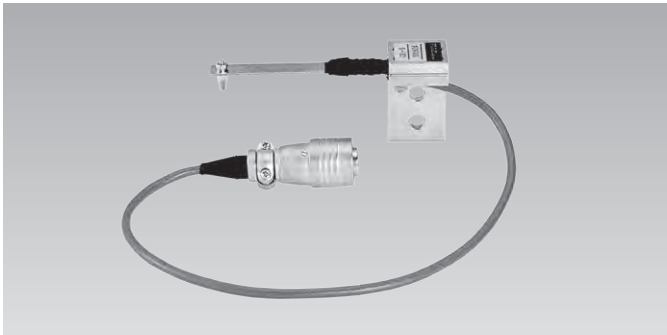

The CE displacement transducer has the structure of strain gage mounted on a cantilever. The high responsiveness to displacement and the simple structure allows this transducer to make accurate and stable measurement and to be installed in a confined space.

Cantilever type

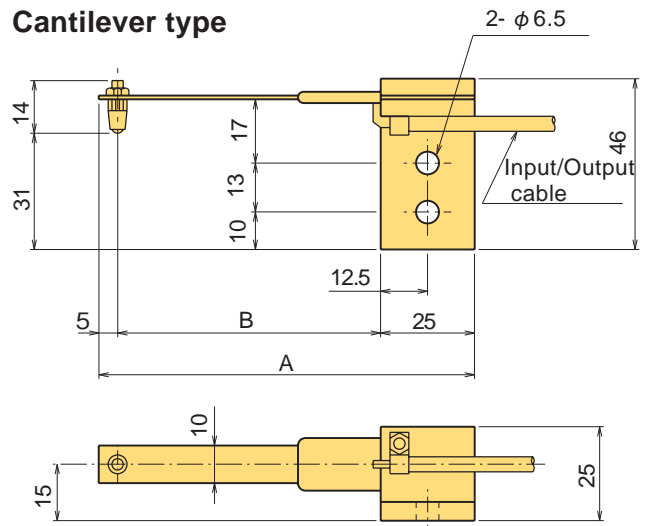

■ SPECIFICATIONS

TYPE	CE-2	CE-5	CE-10
Capacity	2mm	5mm	10mm
Rated Output	2.5mV/V(5000×10 ⁻⁶ strain)		
Sensitivity(x10 ⁻⁶ strain)/mm	2500	1000	500
Non-linearity	1%RO		
Spring force	7.1N	4.7N	3.2N
Frequency response	110Hz	45Hz	25Hz
Allowable temperature range	0 ~ +40°C		
Input/Output resistance	350Ω		
Recommended exciting voltage	2V or less		
Allowable exciting voltage	10V		
Weight	90g	90g	95g

Supplied cable : CT6-4V5/NJ-STB (φ6mm 0.3mm² 4-core shielded vinyl cable 5m)

■ DIMENSIONS

TYPE	A	B
CE-2	75	45
CE-5	100	70
CE-10	130	100

DISPLACEMENT TRANSDUCERS

RA/RA-L Clip-shape Displacement Transducer

2/5mm

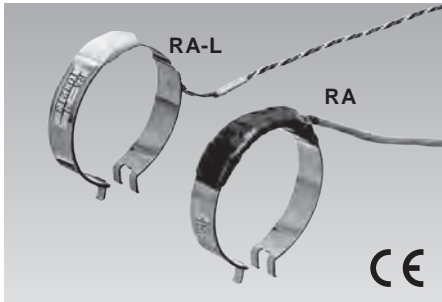

Clip-on type

The RA Clip-shape Displacement Transducer is designed to measure crack opening displacement(COD) in metal.
The RA-L Cryogenic Clip-shape Displacement Transducer is designed to measure crack opening displacement(COD) in metal under low-temperature conditions.

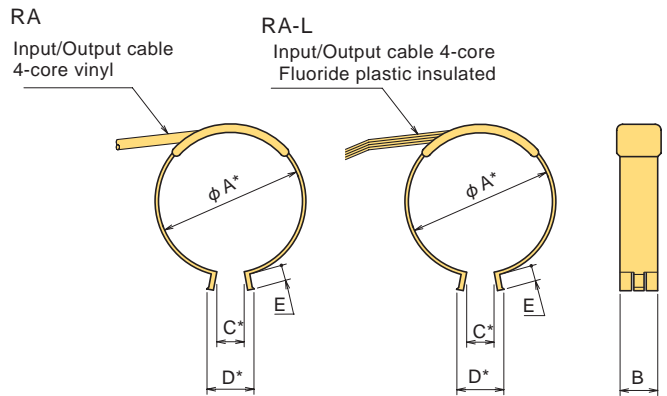

* : Approximate value

■ SPECIFICATIONS

TYPE	RA-2 / RA-2L	RA-5 / RA-5L
Capacity	2 (2~4) mm	5 (2~7) mm
Rated Output	1mV/V(2000×10 ⁻⁶ strain)	1.5mV/V(3000×10 ⁻⁶ strain)
Sensitivity(x10 ⁻⁶ strain)/mm	1000	600
Non-linearity	1%RO	
Allowable temperature range	RA-2/RA-5 : 0 ~ +40°C RA-2L/RA-5L : -196 ~ +40°C	
Input/Output resistance	350Ω	
Recommended exciting voltage	2V or less	
Allowable exciting voltage	10V	
Weight	RA-2 : 31g RA-2L : 22g	RA-5 : 35g RA-5L : 28g

Input/Output cable : RA-2/RA-5 : ϕ 3mm 0.09mm² 4-core vinyl cable 2m
: RA-2L/RA-5L : 0.08mm² 4-core Fluoride plastic insulated cable 2m

■ DIMENSIONS

TYPE	ϕA	B	C	D	E
RA-2 / RA-2L	40	10	8	13	5
RA-5 / RA-5L	50	12	14	19	10

NB: Calibration of RA-L for cryogenic use is available only at room temperature

■ ACCESSORY

Fixing Jig RAF-11

The RAF-11 is pre-mounted on test specimen in order to clasp-mount the RA and RA-L.

UB / UB-A Clip-shape Displacement Transducer

2/5mm

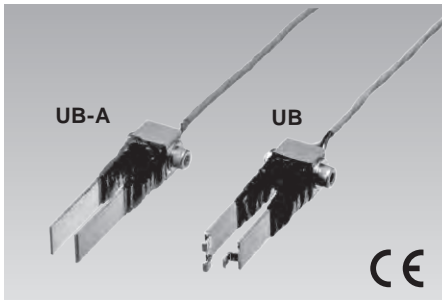

Clip-on type

The UB and UB-5A Clip-shape Displacement Transducers are designed to measure crack opening displacement(COD) in metal.
The UB-5A has a shape of the tip conforms to ASTM specifications.

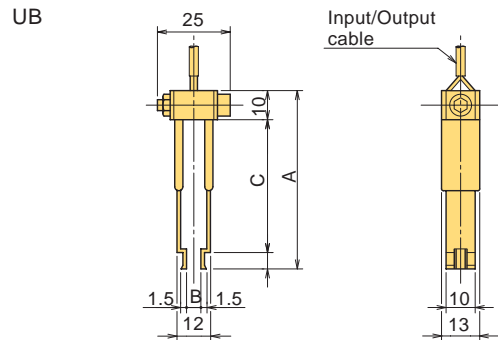

■ DIMENSIONS

TYPE	A	B	C
UB-2	40	2	26
UB-5	60	5	46

■ ACCESSORY

Fixing Jig RAF-11

The RAF-11 is pre-mounted on test specimen in order to clasp-mount the UB.

■ SPECIFICATIONS

TYPE	UB-2	UB-5	UB-5A
Capacity	2 (2~4) mm	5 (2~7) mm	5 (3~8) mm
Rated Output	2.5mV/V(5000×10 ⁻⁶ strain)	2.5mV/V(5000×10 ⁻⁶ strain)	2.5mV/V(5000×10 ⁻⁶ strain)
Sensitivity(x10 ⁻⁶ strain)/mm	2500	1000	1000
Non-linearity	1%RO		1%RO
Allowable temperature range	0 ~ +40°C		0 ~ +40°C
Input/Output resistance	350Ω		350Ω
Recommended exciting voltage	2V or less		2V or less
Allowable exciting voltage	10V		10V
Weight	39g	42g	42g

Input/Output cable : ϕ 3mm 0.09mm² 4-core vinyl cable 2m

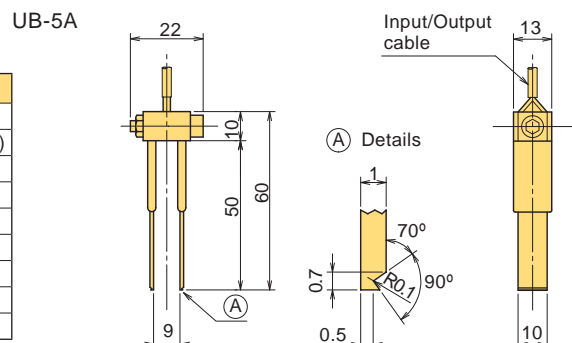

DISPLACEMENT TRANSDUCERS

Displacement Transducers Accessories

Contact Tip DF-11

The DF-11 is used with OU/CE/DDP-A/SDP-C/SDP-CT type displacement transducer.

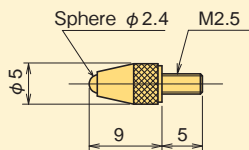

Contact Tip DF-15

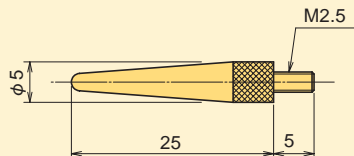

Contact Tip DF-12

The DF-12 is used with SDP-D type displacement transducer.

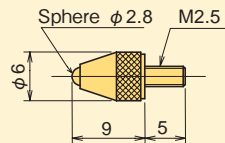

Contact Tip DF-16

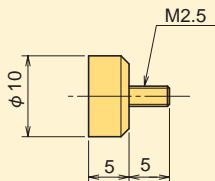

Contact Tip DF-13

The DF-13 is used with CDP type displacement transducer.

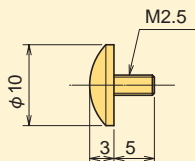

Contact Tip DF-17

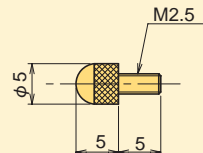

Contact Tip DF-14 with roller

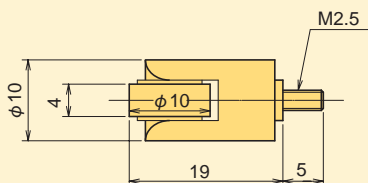

Hook Bolt SDPF-13

The SDPF-13 is used with SDP-CT displacement transducer. Also available with SDP-D and CDP-T for tension displacement use.

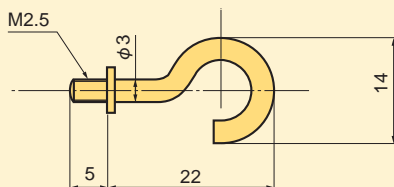

Holder CDPF-11/-12

The CDPF-11 is used to mount CDP displacement transducer, and the CDPF-12 to mount CDP-M/-MT.

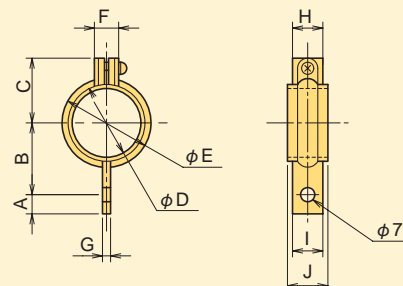

Magnet Stand MB

The MB is used to mount displacement transducers.

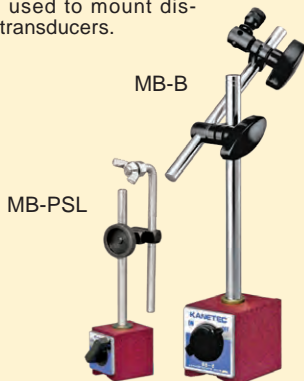

Fixing Jig RAF-11

The RAF-11 is pre-mounted on test specimen in order to clasp-mount RA or UB type displacement transducer.

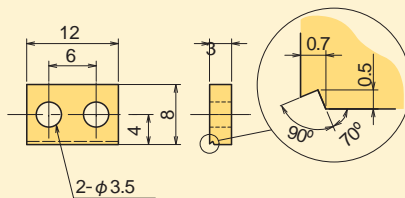

Type	Applicable transducers
CDPF-11-25	CDP-5~25, -5~25B, CDP-50M/-MT, CDP-25T, FDP-10A~-100A
CDPF-11-50	CDP-50, -50-D, CDP-100M/-MT
CDPF-11-100	CDP-100, -100-D
CDPF-12-25	CDP-5M~25M, CDP-5MT~25MT

Type	A	B	C	φ D	φ E	F	G	H	I	J
CDPF-11-25	10	28	25	20.5	30	13	5	15	15	20
CDPF-11-50	10	35	32	33.5	43	13	5	15	15	20
CDPF-11-100	11	36	40	41	50	17.5	8	14	16	25
CDPF-12-25	7	17.5	16.5	10.4	15	9	5	10	10	15

Fixing Jig PIF-21

The PIF-21 is pre-mounted on concrete and other test specimen in order to screw-mount PI type displacement transducer.

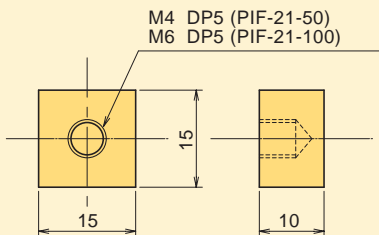

Type	Applicable transducer
PIF-21-50	PI-2-50 / PI-5-50
PIF-21-100	PI-2-100 / PI-5-100
	PI-2-150 / PI-5-150
	PI-2-200 / PI-5-200
	PI-2-250 / PI-5-250
	PI-2-300 / PI-5-300

Dummy Plate PIF-11

The PIF-11 is used to maintain the proper gauge length when mounting the PIF-21 Fixing Jig on test specimen.

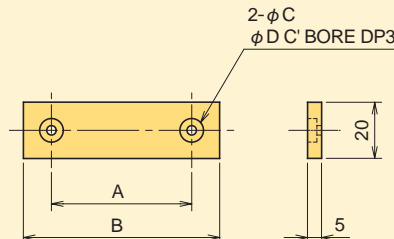

Type	Applicable transducer	A	B	φ C	φ D
PIF-11-50	PI-2-50 / PI-5-50	50	70	4.1	8
PIF-11-100	PI-2-100 / PI-5-100	100	120	6.1	12
PIF-11-150	PI-2-150 / PI-5-150	150	170	6.1	12
PIF-11-200	PI-2-200 / PI-5-200	200	220	6.1	12
PIF-11-250	PI-2-250 / PI-5-250	250	270	6.1	12
PIF-11-300	PI-2-300 / PI-5-300	300	320	6.1	12

DISPLACEMENT TRANSDUCERS

EDP-A / EDP-B Extensometer 5mm

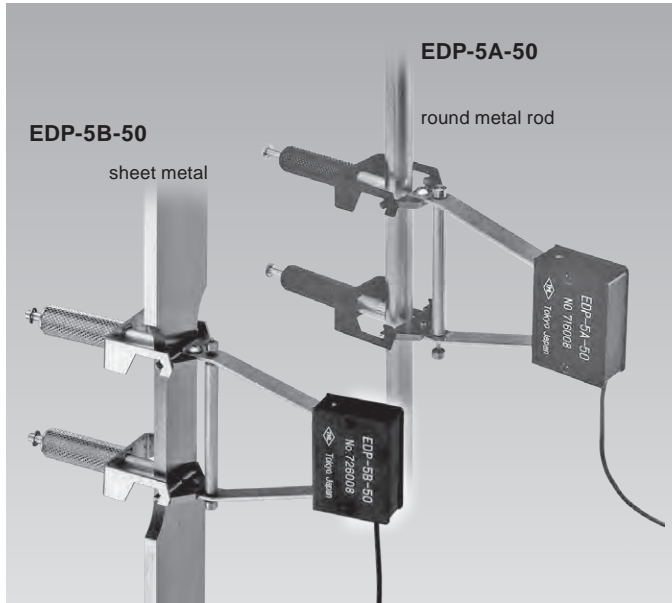

The EDP series extensometer is designed to measure elongation in round metal rod or sheet metal test specimen. It has a special holder that simply and securely holds it in place, and it detects elongation in test specimen based on displacement between two knife edges. This series uses a strain gauge for the sensing element and can be connected to an ordinary strainmeter for high precision measurements.

Protection ratings: IP20 equivalent

For materials tension test

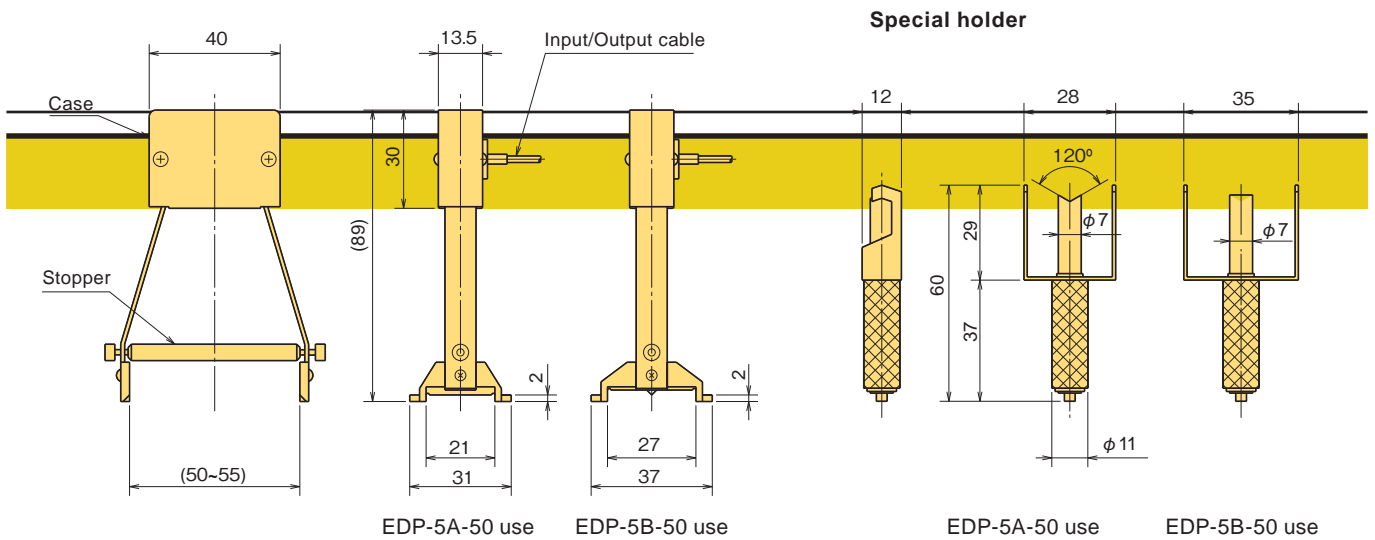

■ SPECIFICATIONS

TYPE	EDP-5A-50	EDP-5B-50
Gauge length	50mm	
Capacity	5mm	
Applicable test specimen	Round bar $\phi 8\sim 20\text{mm}$	Plate 5~17mm thickness 10~25mm width
Rated Output	3mV/V(6000 $\times 10^{-6}$ strain)	
Sensitivity	1200 $\times 10^{-6}$ strain/mm	
Non-linearity	0.3%RO	
Allowable temperature range	0 ~ +40°C (No condensation)	
Input/Output resistance	350 Ω	
Recommended exciting voltage	2V or less	
Allowable exciting voltage	10V	
Weight	Extensometer: 30g Holder (a pair) : 40g	

Input/Output cable : $\phi 2.2\text{mm}$ 0.05mm² 4-core shielded vinyl cable 2m

Mass concrete opening displacement

KJA-A/KJB-A Joint-meter

Civil engineering design



Excellent waterproofness
Long term stable measurement
Easy Installation

These models are used to measure joint opening displacement of mass concrete. Two models are ready for different applications. The KJA-A Joint-Meter is embedded in an exclusive socket mounted to concrete blocks made of mass concrete or other materials, and is used to measure joint opening displacement. The KJB-A is used to measure displacement on concrete surfaces or underwater simply by manufacturing appropriate fittings. Moreover, these models are available for waterproof type displacement transducer. Optional model with built-in thermocouple unit can be supplied.

Protection ratings : IP 68 equivalent

INSTALLATION EXAMPLE

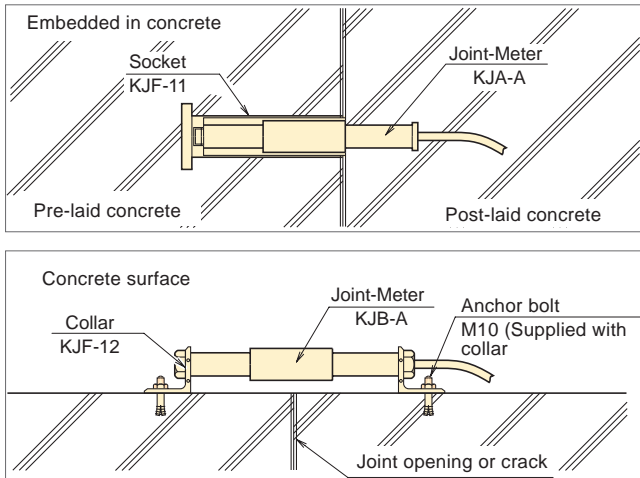

KJA-A

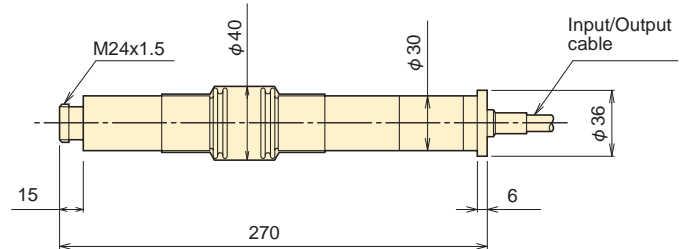

KJB-A

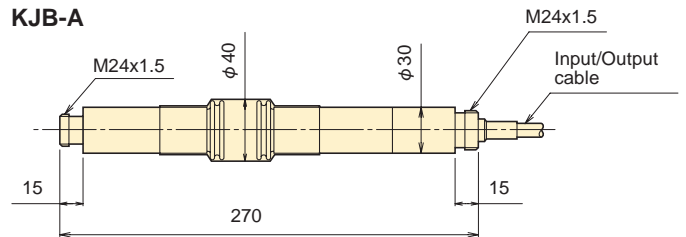

SPECIFICATIONS

TYPE	KJA-5A KJB-5A	KJA-10A KJB-10A	KJA-20A KJB-20A	KJA-50A KJB-50A
Capacity	5mm	10mm	20mm	50mm
Rated Output	1mV/V (2000×10 ⁻⁶ strain)			
Non-linearity	1%RO			
Allowable temperature range	-20 ~ +80°C			
Input/Output resistance	350Ω			
Recommended exciting voltage	2V or less			
Allowable exciting voltage	10V			
Weight	700g			

Input/Output cable : φ9mm 0.5mm² 4-core shielded chloroprene cable 2m

ACCESSORY

Socket KJF-11 KJA-A use

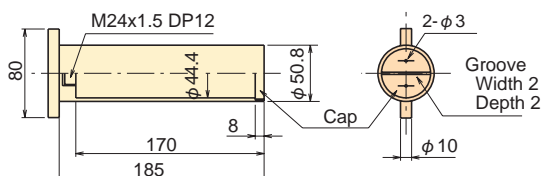

Collar KJF-12 KJB-A use

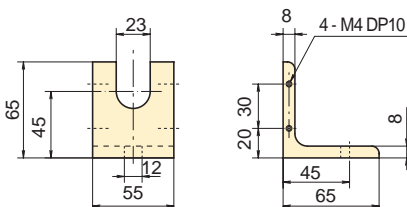

Dummy plate KJF-13 KJB-A use

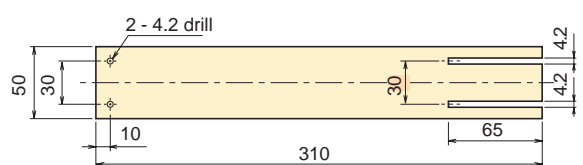

Protective cover KJF-14 KJB-A use

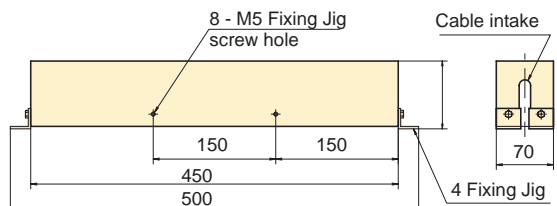

Concrete crack displacement

KG-A Crack Displacement Transducer

Civil engineering design



CE

The KG-A crack displacement transducer is set across a crack on the surface of concrete or across a joint between two concrete layers to measure the displacement of openings. The waterproof feature allows this transducer to make accurate and stable measurement outdoors over a long period of time. It is mounted using an anchor bolt (KGF-11) or a mounting metal piece (KGF-31).

Protection ratings : IP 65 equivalent

Drip-proof structure
Excellent stability over a long period of time
High sensitivity, High accuracy
Compact, Easy to handle

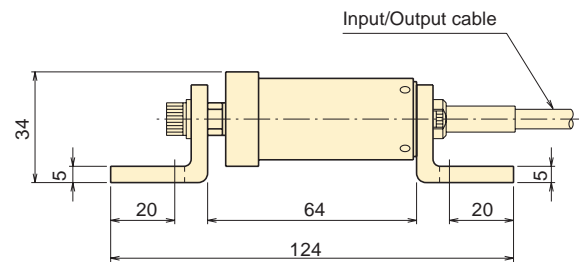
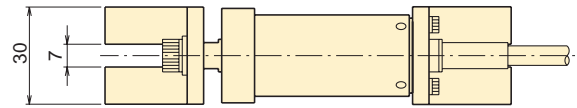

■ SPECIFICATIONS

TYPE	KG-2A	KG-5A
Capacity	±2mm	±5mm
Rated Output	1.5mV/V (3000×10 ⁻⁶ strain)	2mV/V (4000×10 ⁻⁶ strain)
Sensitivity	1500×10 ⁻⁶ strain/mm	800×10 ⁻⁶ strain/mm
Non-linearity	0.5%RO	1%RO
Spring force	15N (1.5kgf)	
Allowable temperature range	-20 ~ +60°C	
Input/Output resistance	350Ω	
Recommended exciting voltage	2V or less	
Allowable exciting voltage	5V	
Weight	180g	

Input/Output cable : φ 6mm 0.35mm² 4-core shielded chloroprene cable 2m

■ ACCESSORY

Anchor Bolt KGF-11

This bolt is used to mount the KG-A transducer. After the bolt is placed on to concrete surface the KG-A is mounted. (2 pcs/set)
Thread M6



Fixing Jig KGF-31

This jig is screw-mounted to the collar of the transducer, and bonded on to concrete surface. (2 pcs/set)



Protective Cover KGF-21

This cover protects the transducer installed on to concrete surface from mechanical damage.



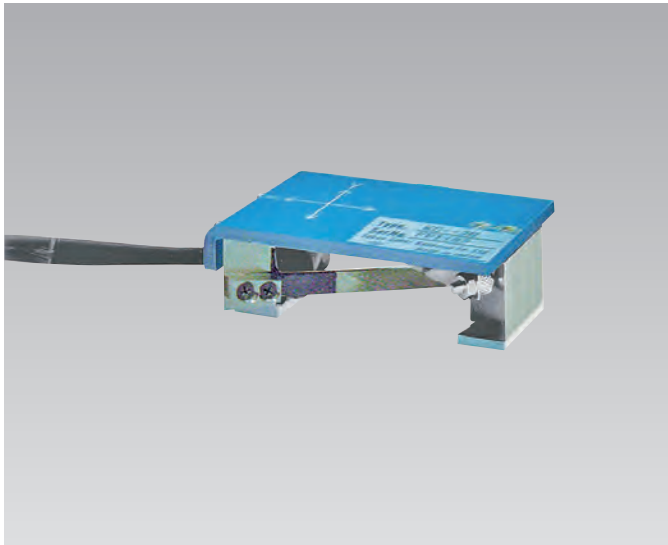

Compact, Light-weight
Easy to handle
Repeated use

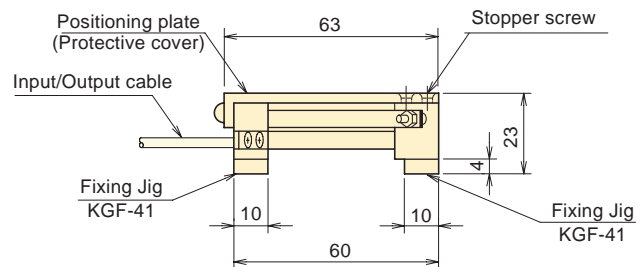
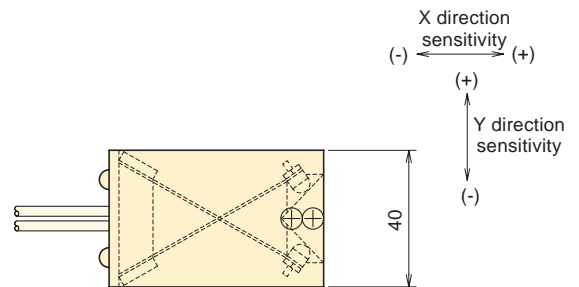

The KG-B crack displacement transducer is used to measure the displacement in two directions simultaneously: the displacement of openings, such as concrete cracks or joints, and the horizontal shear displacement. It is mounted on a structure by bonding with adhesive. Because the fixing jigs are detachable, the transducer can be demounted and set on a different structure. This allows this transducer to be used repeatedly on different structures. In addition, the small-size feature makes this transducer suitable for indoor measurement.

■ SPECIFICATIONS

TYPE	KG-3B
Capacity	X-direction : -2mm~+4mm Y-direction : ±3mm
Rated Output	X-direction : Approx. -1~+2mV/V (-2000~+4000×10 ⁻⁶ strain) Y-direction : Approx. ±1.5mV/V (±3000×10 ⁻⁶ strain)
Sensitivity	Approx. 1000×10 ⁻⁶ strain/mm
Non-linearity	1%RO
Cross sensitivity	X-direction : 1.5%RO Y-direction : 2.0%RO
Allowable temperature range	0 ~ +40°C
Input/Output resistance	350Ω
Recommended exciting voltage	2V or less
Allowable exciting voltage	5V
Fixing Jig	1 pc.
Weight	180g

Input/Output cable : φ3mm 0.05mm² 4-core shielded chloroprene cable 2m, 2 pcs.

■ ACCESSORY

Fixing Jig KGF-41

This jig is bonded onto concrete surface to mount the transducer. (2 pcs/set)



Dummy plate KGF-61

This plate is temporarily mounted to maintain proper gauge length for installation of the transducer with KGF-41 jig.



Land slide measurement

KLG-A/NKLG-AB Ground Extension Gauge

Civil engineering design

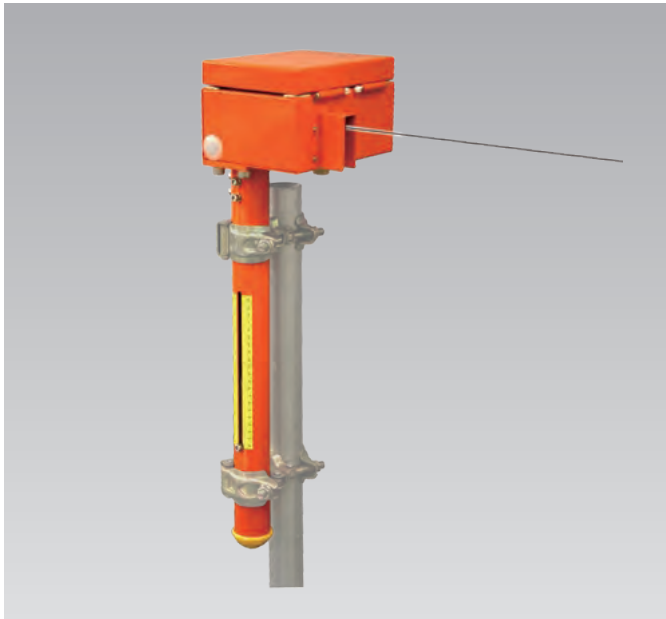

Remote measurement
Excellent stability
Easy to handle
Electrical insulation function

BUILT-IN ARRESTOR

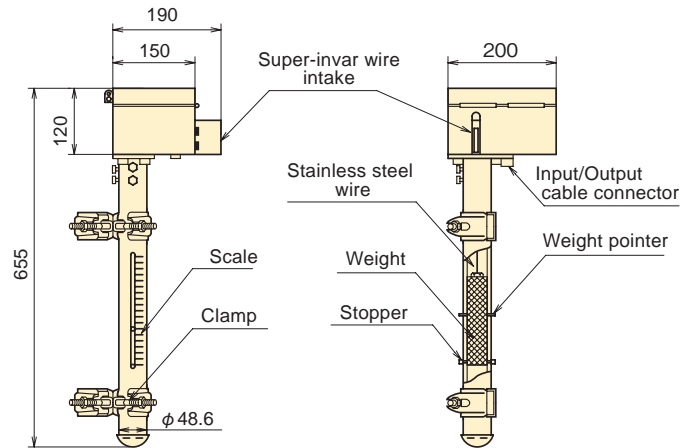

The KLG-A ground extension gauge is used to measure the displacement of a ground surface. A super-invar wire is set between a stanchion at a reference point (fixed stanchion) and a stanchion at a measurement position (mobile stanchion) and this gauge is mounted on the stanchion at the reference point. The waterproof and environmental resistance features make this gauge suitable for on-site measurement work. The NKLG-AB model is designed specifically for use with the network measurement system TML-NET.

Protection ratings : IP 65 equivalent

PRINCIPLE AND APPLICATION

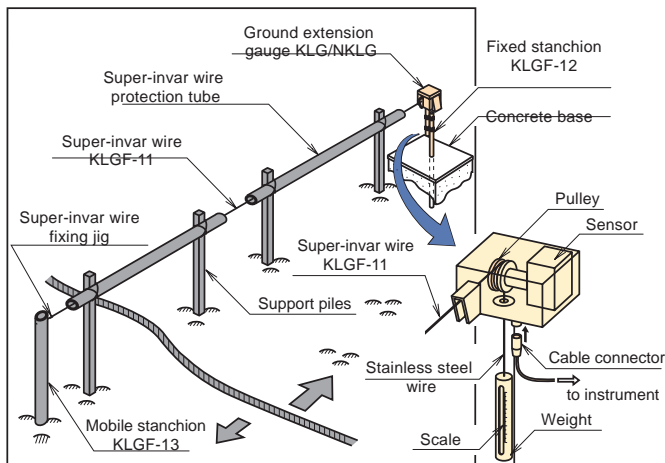

COMPATIBLE ACCESSORY

With KLG-A/NKLG-AB/KLG-B/NKLG-BB



KLG-11



KLG-14

KLG-A SPECIFICATIONS

TYPE	KLG-200A
Capacity	200mm
Rated Output	2.5mV/V (5000×10 ⁻⁶ strain)
Non-linearity	1%RO
Allowable temperature range	-20 ~ +60°C (No icing)
Input/Output resistance	350Ω
Recommended exciting voltage	2V or less
Allowable exciting voltage	5V
Weight	10 kg

Input/Output cable :

CT9-4N2/WP-STB (φ9mm 0.5mm² 4-core shielded chloroprene cable 2m)

NKLG-AB SPECIFICATIONS

TYPE	NKLG-200AB
Capacity	200mm
Rated indication	Approx. 5000 digits
Non-linearity	1%RO
Allowable temperature range	-20 ~ +60°C (No icing)
Channel set	Factory default (000~ 999)
Weight	10 kg

Supplied cable :

CT6-2R2/WP-STB (φ6mm 0.5mm² 2-core shielded vinyl cable 2m)

To activate electrical insulation function it requires the dedicated instrument as below.

TDS-540-03 and NDR-100, or TDS-150-06 including an option for Switching box/TML-NET driving board

Super-Invar wire KLG-11

The KLG-11 Super-Invar Wire is a wire used to connect an extension gauge to a mobile stanchion in order to transmit displacement. 0.5mm-dia. × 30m (Thermal expansion 1ppm or less)

Fixed Stanchion KLG-12

The KLG-12 Fixed Stanchion is installed at a reference point and is used to mount an extension gauge.

48.6mm-dia. × 1.5m

Mobile Stanchion KLG-13

The KLG-13 mobile Stanchion is installed at a measurement point and is used for fixing the other end of the Super-Invar Wire drawn from the extension gauge.

48.6mm-dia. × 1.5m

Crimp Pliers KLG-14

The KLG-14 Crimp Pliers are used to crimp the wire locks supplied with the Super-Invar Wire.

KLG-B/NKLG-BB Ground Extension Gauge

Civil engineering design



Remote measurement
Excellent stability
Easy to handle
Electrical insulation function

BUILT-IN ARRESTOR

The KLG-B ground extension gauge is placed near the ground surface to measure the displacement of a ground slide. A super-Invar wire is set between a stanchion at a reference point (fixed stanchion) and a stanchion at a measurement position (mobile stanchion) and this gauge is mounted on the stanchion at the reference point. The waterproof and environmental resistance features make this gauge suitable for on-site measurement work. The NKLG-BB model is designed specifically for use with the network measurement system TML-NET.

Protection ratings : IP 55 equivalent

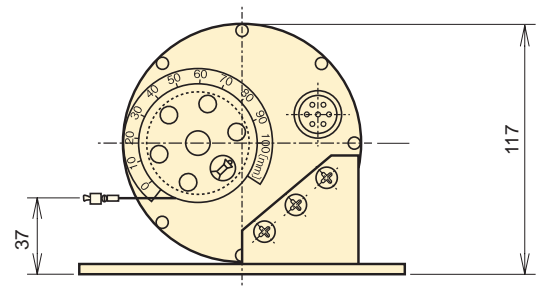
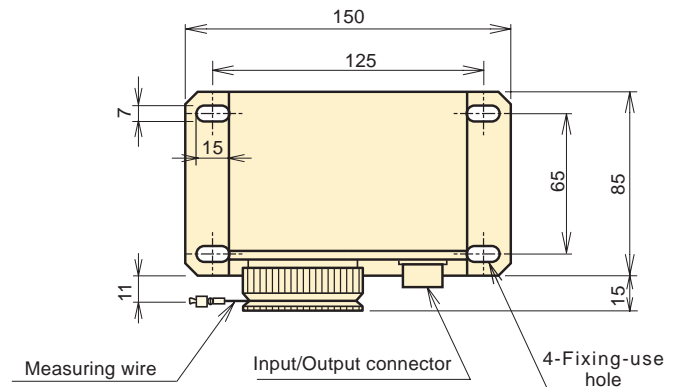

■ KLG-B SPECIFICATIONS

TYPE	KLG-100B
Capacity	100mm
Rated Output	Approx. 2.5mV/V (5000×10 ⁻⁶ strain)
Non-linearity	1%RO
Allowable temperature range	-20 ~ +60°C (No icing)
Input/Output resistance	350Ω
Recommended exciting voltage	2V or less
Allowable exciting voltage	5V
Weight	1.2 kg

Input/Output cable :

CT9-4N2/WP-STB (φ 9mm 0.5mm² 4-core shielded chloroprene cable 2m)

■ NKLG-BB SPECIFICATIONS

TYPE	NKLG-100BB
Capacity	100mm
Rated indication	Approx. 5000 digits
Non-linearity	1%RO
Allowable temperature range	-20 ~ +60°C (No icing)
Channel set	Factory default (000- 999)
Weight	1.2 kg

Input/Output cable :

CT6-2R2/WP-STB (φ 6mm 0.5mm² 2-core shielded vinyl cable 2m)

To activate electrical insulation function it requires the dedicated instrument as below.

TDS-540-03 and NDR-100, or TDS-150-06 including an option for Switching box/TML-NET driving board

■ KLG-B/NKLG-BB DEDICATED ACCESSORY

Mounting plate KLG-15

This dedicated plate is usable to mount the extension gauge KLG-B/NKLG-BB.

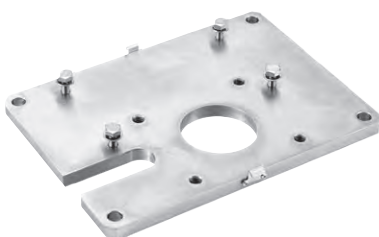

Protective cover KLG-16

This dedicated cover is usable to protect the extension gauge KLG-B/NKLG-BB mounted on plate KLG-15



Stanchion mount adapter KLG-17

This dedicated adapter is usable to fix the extension gauge KLG-B/NKLG-BB mounted on the plate KLG-15 to the stanchion accessory KLG-12.



Ground level settlement

KLA-A/NKLA-B Settlement Transducer

Civil engineering design

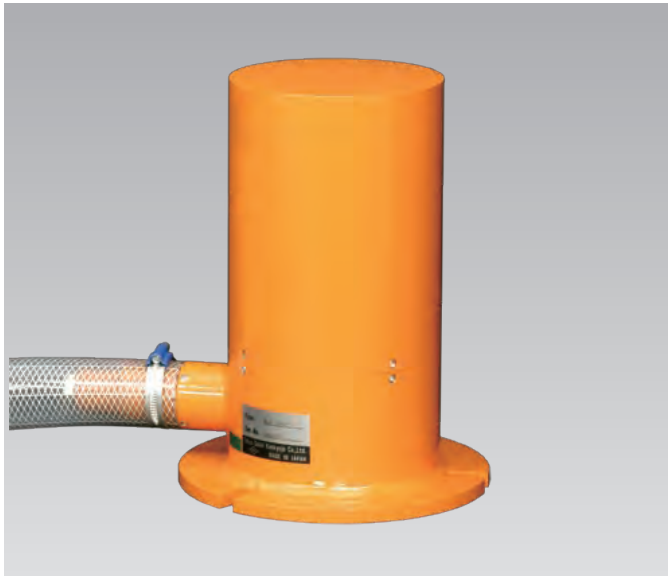

The KLA-A Settlement Transducers is set on a ground surface to measure the settlement of each ground layer. The NKLA-A is also for the same measurement while it can be used with the network measurement system TML-NET. Special anchors are mounted at specified positions inside a borehole and the amount of positional displacement between each anchor and the ground surface level is measured. Anchors can be mounted at the maximum of six levels inside one borehole..

Protection ratings : IP 45 equivalent

Remote measurement

Measures the amount of settlement of ground layers at the maximum 6 positions.

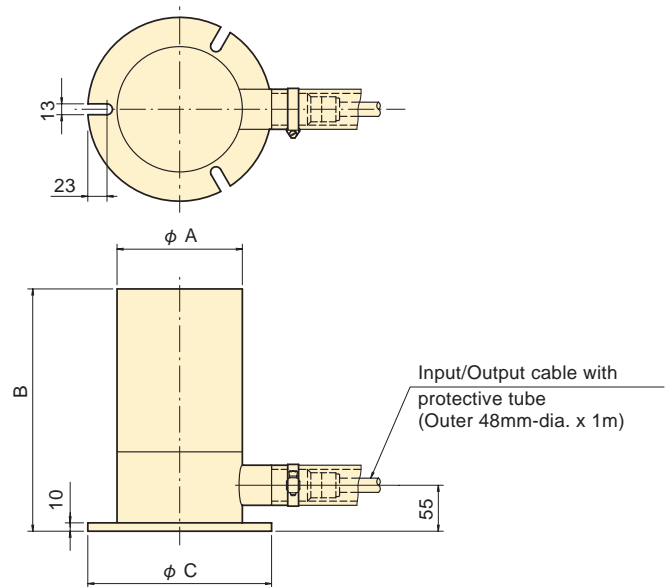

TYPE	ϕ A	B	ϕ C	D
KLA-100A/NKLA-100B	150	290	220	23
KLA-200A/NKLA-200B	200	360	260	15

PRINCIPLE AND APPLICATION

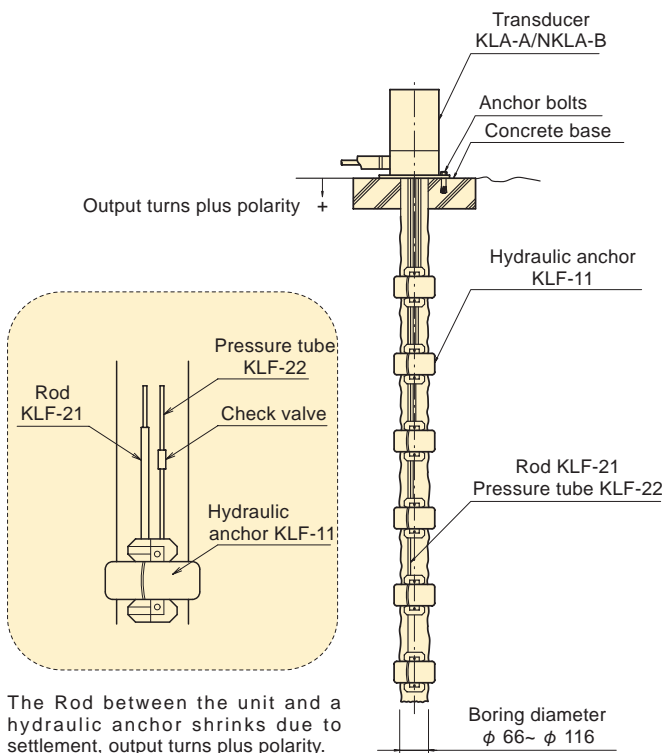

The Rod between the unit and a hydraulic anchor shrinks due to settlement, output turns plus polarity.

KLA-A SPECIFICATIONS

TYPE	KLA-100A-X	KLA-200A-X
Measuring point	1~6 points (-X filled with the specified points)	
Capacity	100mm	200mm
Rated Output	Approx. 2.5mV/V (5000x10 ⁻⁶ strain)	
Non-linearity	1%RO	
Allowable temperature range	-20 ~ +60°C (No icing)	
Input/Output resistance	350Ω	
Recommended exciting voltage	2V or less	
Allowable exciting voltage	5V	
Weight	5 kg	4.5~6 kg

Input/Output cable

for 1~3 points: ϕ 11.5mm 0.3mm² 12-core shielded vinyl cable 2m
for 4~6 points: ϕ 16.5mm 0.3mm² 24-core shielded vinyl cable 2m

NKLA-B SPECIFICATIONS

TYPE	NKLA-100B-X	NKLA-200B-X
Measuring point	1~6 points (-X filled with the specified points)	
Capacity	100mm	200mm
Rated indication	Approx. 5000 digits	
Non-linearity	1%RO	
Allowable temperature range	-20 ~ +60°C (No icing)	
Channel set	Factory default (000~ 999)	
Weight	5 kg	5~7 kg

Supplied cable

CT6-2R2/WP-STB ϕ 6mm 0.5mm² 2-core shielded vinyl cable 2m

To activate electrical insulation function it requires the dedicated instrument as below.

TDS-540-03 and NDR-100, or TDS-150-06 including an option for Switching box/TML-NET driving board

CM Compressometer

Civil engineering design

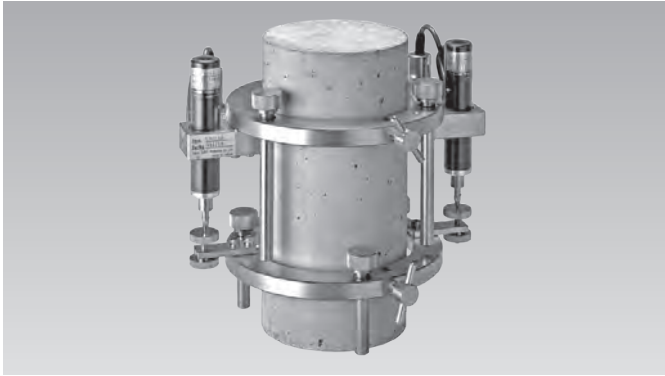

- Easy to install
- Repeated use
- Easy drawing of stress- strain curve

The CM compressometer is designed to conduct a strength test. It measures the axial strain on a cylindrical concrete specimen placed in and secured by screws to the inner chamber of this compressometer. It uses a high-sensitivity displacement transducer to measure the amount of strain. By multiplying a measurement by a certain factor, the amount of strain can be calculated as a numerical value. Unlike the case of ordinary strain gauges, this compressometer is simple and easy to operate and can be used repeatedly. However, it cannot be used to conduct breaking tests.

SPECIFICATIONS

TYPE	CM-10	CM-12	CM-15
Applicable specimen	φ 10x20 cm	φ 12.5x25 cm	φ 15x30 cm
Gauge length	100mm	125mm	150mm
Capacity	50000×10 ⁻⁶ strain	40000×10 ⁻⁶ strain	33000×10 ⁻⁶ strain
Input/Output resistance	350Ω		
Recommended exciting voltage	2V or less		
Allowable exciting voltage	10V		
Weight	2.5 kg	3.1 kg	3.7 kg

Supplied cable : CT6-4V10/NP-STB (φ 6mm 0.3mm² 4-core shielded vinyl cable 10m)

DIMENSIONS

TYPE	φ A	B	φ C	D
CM-10	150	200	100	50
CM-12	185	250	125	62.5
CM-15	210	300	150	75

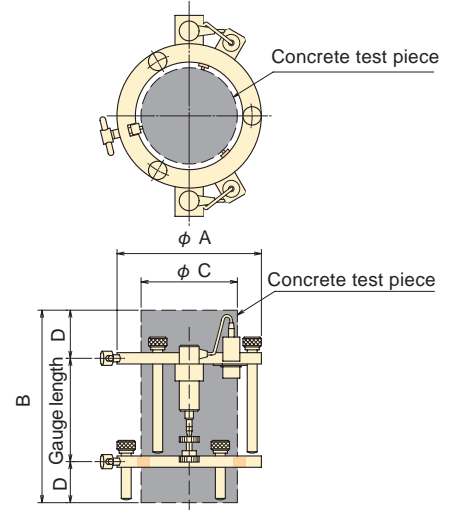

CM-H Compressometer (Destructive)

Civil engineering design

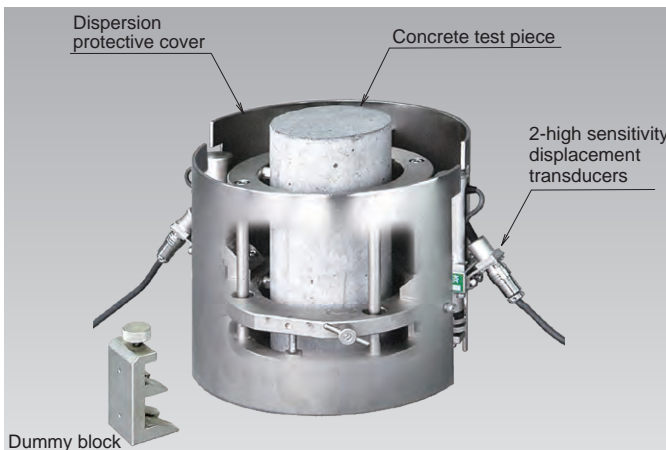

The CM-10H compressometer is designed to measure compressive strain of cylindrical specimen made of ordinary concrete or high-strength concrete under loading test. It uses high sensitive displacement transducers for measurement of strain, and is constructed not to apply excessive displacement to the transducers even after the specimen is broken. In addition, it is equipped with protective covers intended to prevent dispersion of fragments of broken specimen. The displacement transducers are also protected with covers. It is very easy to set a specimen to the compressometer. A wet concrete specimen, which is just after taken out from underwater curing, can also be measured. When used together with load cell CLL-NA or CLH-NA, it is possible to measure the modulus of static elasticity.

- Usable till destruction of a specimen
- Easy to install
- Possible strain measurement of wet specimen
- Repeated use

SPECIFICATIONS

TYPE	CM-10H
Applicable specimen	φ 10x20 cm
Gauge length	100mm
Capacity	20000×10 ⁻⁶ strain
Input/Output resistance	350Ω
Weight	4.5 kg

Supplied cable : CT6-4V3/SNP-STB (φ 6mm 0.3mm² 4-core shielded vinyl cable 3m)

OPTION

Mounting jigs to position concrete test specimen are replaceable with option as damaged.

CMF-11H Fixed edge



CMF-12H Movable edge



CMF-13H Handle screw

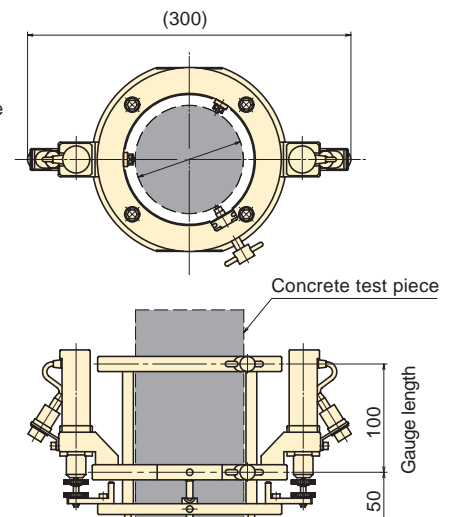
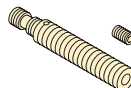

PRESSURE TRANSDUCERS

TML Pressure Transducers electrically detect the gauge pressure of fluids like oil and water or gases like air. Our pressure transducers have sensing elements that use TML strain gauges made exclusively for transducers, and they can be used for consistent, highly reliable measurements over long periods of time. Our PW-PA, PWH and PW-PAH models are cavity type pressure transducers ideal for high precision static measurements, and PWF, PWFA, PWFC, PWFD and PWFE models have flush diaphragm structures best suited for dynamic measurements. PWFA model is with built-in amplifier, capable of high temperature use up to 120 deg. C. and the output voltage is 0.5~5V. PW-PAH model is designed for high temperature use up to 170 deg. C with smaller size. And PDA/PDB models are Miniature Pressure gauges. Their sensing part is 7.6mm-dia. and 2mm-thick.

OUTPUT POLARITY WITH A LOAD

The measured value changes in positive(+) direction with increase of pressure..

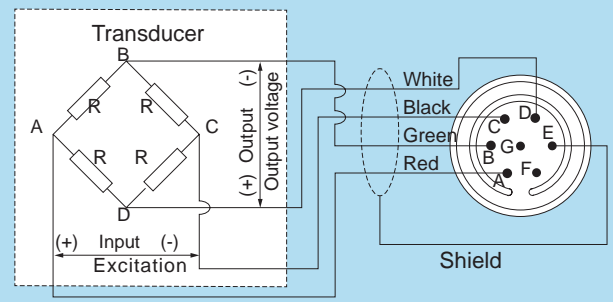

Not applicable to some products.

Pressure transducer selection

Utility	Type	Capacity (kPa)				Capacity (MPa)												Page	
		50	100	200	500	1	2	3	5	10	20	30	50	70	100	150	200		
High precision	PW-PA		●	●	●	●	●		●	●	●	●							62
High capacity, High sensitivity	PWH-PA													●	●	●	●		62
High temperature use upto 170 deg C	PW-PAH						●		●	●	●		●						63
Built-in amplifier, High temperature use	PWFA-PA						●		●	●	●								63
Flush diaphragm	PWF-PB					●	●		●	●	●		●						64
Flush diaphragm, Small G1/8 screw	PWFC-PB						●		●	●	●		●						64
Flush diaphragm, M8 bolt shape	PWFD-PB						●		●	●	●								65
Flush diaphragm, M6 bolt shape	PWFE-PA						●		●	●	●								65
Miniature, 7.6mm-dia. 2mm-thick	PDA-PB	●	●	●	●	●	●	●											66
Miniature, 7.6mm-dia. 2mm-thick	PDB-PB	●	●	●	●	●	●	●											66

EXAMPLE OF PRESSURE TRANSDUCER USE

Static measurement
Measuring static water (oil) pressure in pressure vessels

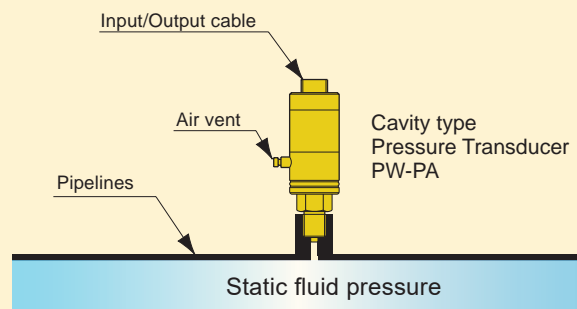

Dynamic measurement
Measuring pressure variation in pipe lines

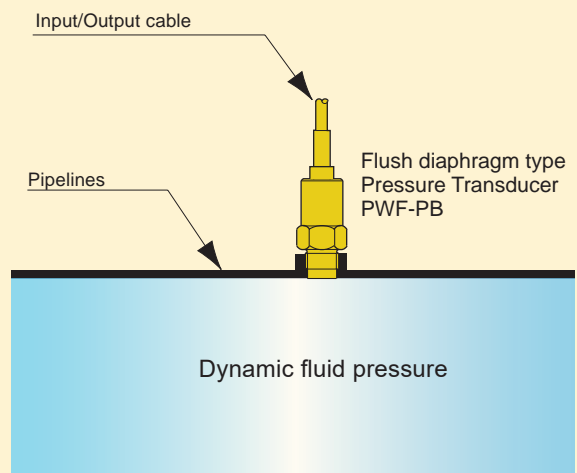

Measuring hydraulic jack loads

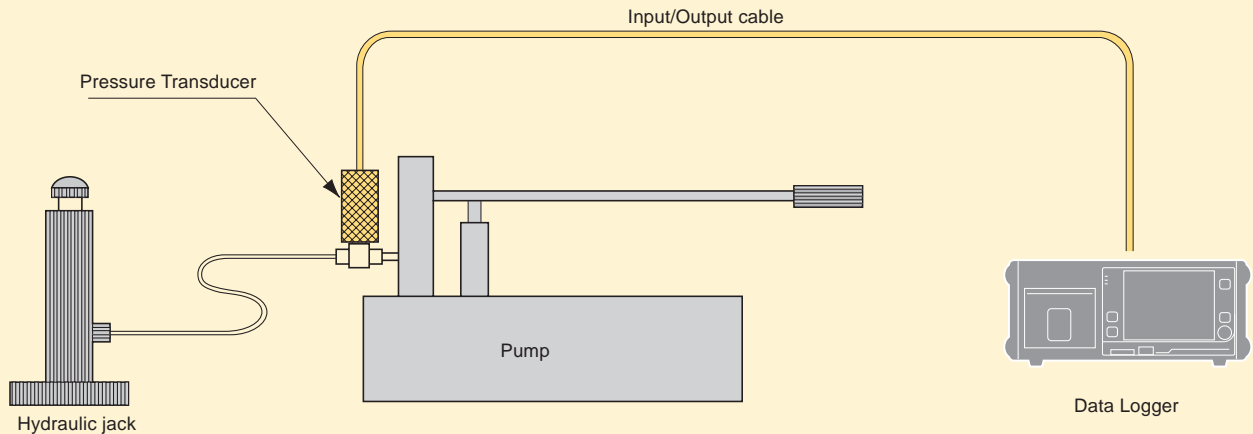

Method used to calculate the conversion coefficient when measuring hydraulic jack load (kN or MN) with a pressure transducer

$$\text{Correction coefficient (K)} = C \times A$$

- K: Correction coefficient
- C: Calibration coefficient for the transducer
- A: Jack cylinder surface area exposed to pressure
- F: Maximum jack load
- P: Maximum jack pressure

Example

Determine the correction coefficient when a pressure transducer is mounted to a jack with a maximum load of 3MN and a cylinder surface area exposed to pressure of 500cm².

$$\text{Maximum jack pressure } P = \frac{F}{A} = \frac{3 \times 10^6}{5 \times 10^{-2}} = 60\text{MPa}$$

Select a pressure transducer with a capacity higher than 60MPa because maximum jack pressure here is 60MPa. In this case, use the PWH-70MPA because it has a capacity of 70MPa.

If the calibration coefficient for the PWH-70MPA is

$$C = 0.035\text{MPa}/1 \times 10^{-6} \text{ strain},$$

then the correction coefficient (K) is

$$C \times A = 0.035 \times 10^6 \times 5 \times 10^{-2}$$

and equals $1.75 \times 10^3\text{N}$.

Converted to MN, we get the following:

$$K = \frac{1.75 \times 10^3 \text{ N}}{1 \times 10^{-6} \text{ strain}} = 0.00175\text{MN}/1 \times 10^{-6} \text{ strain}$$

Therefore Data Logger TDS-540 settings are as follows:

```
Sensor Mode : 4 GAGE
Coefficient  : +0.00175 E+0
Unit        : MN
Point       : ###.###
```

Settings are entered, screen displays the reflected functions.

```
Coefficient : 1.75000 E-3
Unit        : MN
Point       : ###.###
```

PRESSURE TRANSDUCERS

PW-PA Pressure Transducer 100kPa~50MPa

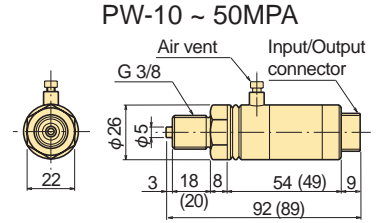
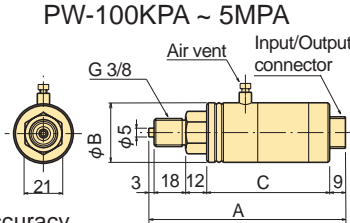

The PW-PA pressure transducer can make stable high-accuracy measurement over a long period of time. It is widely used in production lines and plants and to measure liquid pressure, air pressure, and so forth in laboratories.

Protection ratings: IP42 equivalent PW-100KPA, 200KPA / IP65 equivalent PW-500KPA~50MPa

■ Dimensions

Figures in parentheses are of PW-50MPa.

TYPE	A	φB	C
PW-100~ 500KPA	105	42	63
PW-1~ 5MPa	112	34	70
PW-10~ 50MPa	As per the figure		

■ SPECIFICATIONS

TYPE	PW-100KPA	PW-200KPA	PW-500KPA	PW-1MPa	PW-2MPa	PW-5MPa	PW-10MPa	PW-20MPa	PW-30MPa	PW-50MPa	
Capacity	100kPa	200kPa	500kPa	1MPa	2MPa	5MPa	10MPa	20MPa	30MPa	50MPa	
Rated Output	1mV/V(2000x 10 ⁻⁶ strain) ±1%	1.5mV/V(3000x10 ⁻⁶ strain) ±1%				2mV/V(4000x10 ⁻⁶ strain) ±1%					
Non-linearity	0.3%RO				0.2%RO						
Hysteresis	0.3%RO				0.2%RO						
Repeatability	0.3%RO				0.2%RO						
Temperature effect on zero					0.02%RO/°C						
Temperature effect on span					0.02%/°C						
Compensated temperature range					-10 ~ +60°C						
Allowable temperature range					-20 ~ +70°C						
Over load					150%						
Ultimate overload rating					300%						
Input/Output resistance					350Ω±1%						
Recommended exciting voltage	3V or less				6V or less						
Allowable exciting voltage	10V				15V						
Mounting thread					G3/8 (PF3/8)						
Materials of pressure media					SUS630						
Weight	530g				400g				200g		

Supplied cable : CT9-4N2/WP-STB (φ9mm 0.5mm² 4-core shielded chloroprene cable 2m) For measurement of negative pressure, please consult us.

PWH-PA High capacity Pressure Transducer 70~200MPa

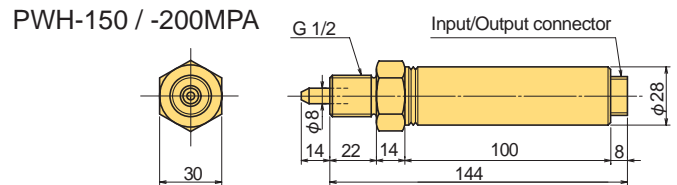
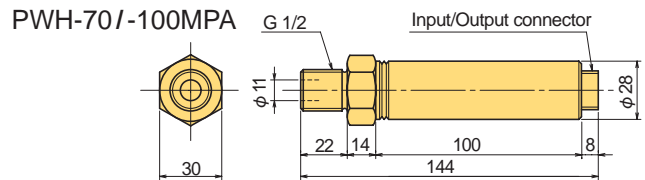

The PWH-PA high-capacity pressure transducer has a sealed structure made with high-strength stainless steel. Using this highly sensitive transducer, stable high-accuracy measurement can be made over a long period of time. It is used to control plant or production lines, to measure jack pressure, and for various other applications.

Protection ratings: IP65 equivalent

■ SPECIFICATIONS

TYPE	PWH-70MPa	PWH-100MPa	PWH-150MPa	PWH-200MPa
Capacity	70MPa	100MPa	150MPa	200MPa
Rated Output	1mV/V(2000x 10 ⁻⁶ strain) ±1%			
Non-linearity	0.2%RO			
Hysteresis	0.2%RO			
Repeatability	0.3%RO			
Temperature effect on zero	0.02%RO/°C			
Temperature effect on span	0.02%/°C			
Compensated temperature range	-10 ~ +60°C			
Allowable temperature range	-20 ~ +70°C			
Over load	150%			
Ultimate overload rating	300%			
Input/Output resistance	350Ω±1%			
Recommended exciting voltage	6V or less			
Allowable exciting voltage	15V			
Mounting thread	G1/2 (PF1/2)			
Materials of pressure media	SUS630			
Weight	400g			410g

High capacity
Available for many fields of industrial application such as plant, production line, jack pressure, etc.

Supplied cable : CT9-4N2/WP-STB (φ9mm 0.5mm² 4-core shielded chloroprene cable 2m)

PRESSURE TRANSDUCERS

PW-PAH High temperature Pressure Transducer

2~50MPa



The PW-PAH pressure transducer is designed to measure pressure in a high temperature with compact size. As the model equipped with a fluoroplastic Input/Output cable, a high temperature pressure measurement is available up to 170°C. These models line up five ranges of 2, 5, 10, 20 and 50MPa.

Protection ratings: IP65 equivalent

PW-2MPAH~ 20MPAH

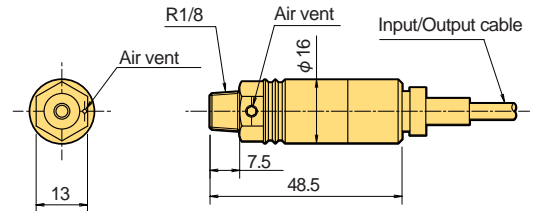

PW-50MPAH

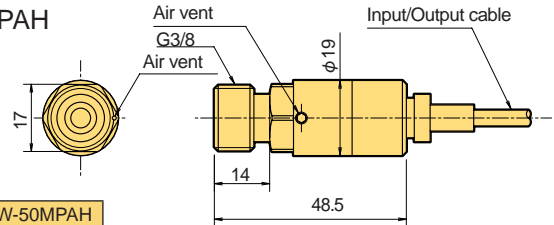

Gases and liquids pressure measurement in high temperature +170°C at max.
Smallest size with 16mm-dia. 48.5mm long

SPECIFICATIONS

TYPE	PW-2MPAH	PW-5MPAH	PW-10MPAH	PW-20MPAH	PW-50MPAH
Capacity	2MPa	5MPa	10MPa	20MPa	50MPa
Rated Output	2mV/V(4000× 10 ⁻⁶ strain) ±25%				
Non-linearity	0.3%RO				
Hysteresis	0.2%RO				
Repeatability	0.2%RO				
Temperature effect on zero	0.008%RO/°C				
Temperature effect on span	0.01%/°C				
Compensated temperature range	-40 ~ +150°C				
Allowable temperature range	-40 ~ +170°C				
Over load	150%				
Input/Output resistance	350Ω				
Recommended exciting voltage	5V or less				
Allowable exciting voltage	10V				
Mounting thread	R1/8 (Male)			G3/8 (Male)	
Materials of pressure media	SUS630				
Weight	50g			70g	

Supplied cable :
 CT4-4F5/SNP-STB (φ4mm 0.08mm² 4-core shielded fluoroplastic resin cable 5m)

PWFA-PA Small High-Temperature Pressure Transducer with built-in amplifier

2~20MPa



The PWFA-PA is a M8 bolt-shaped flush diaphragm pressure transducer with a built-in strain amplifier. Since the PWFA-PA is small sized and can be used for dynamic measurement in high temperature ranges, it is most suited to in-vehicle measurement of hydraulic oil pressure of engine, motor, transmission, oil pump and so on.

Protection ratings: IP65 equivalent

Excellent anti-vibration characteristics
Measurement possible in high temperature up to 120°C
Light weight of 45 g, which is less than half of conventional products.
Overall length after installation is 32 mm, which is less than one third of conventional products

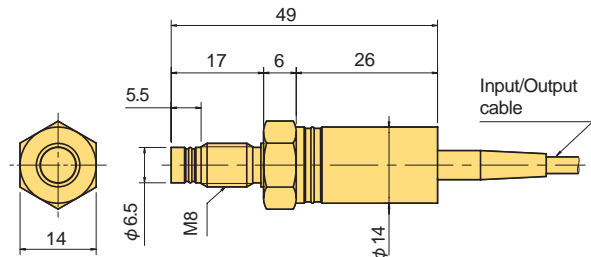

SPECIFICATIONS

TYPE	PWFA-2MPA	PWFA-5MPA	PWFA-10MPA	PWFA-20MPA
Capacity	2MPa	5MPa	10MPa	20MPa
Output voltage	0.5 ~ 5V			
Non-linearity	0.5%RO			
Hysteresis	0.3%RO			
Temperature effect on zero	0.1%RO/°C			
Temperature effect on span	0.03%/°C			
Compensated temperature range	-20 ~ +120°C			
Allowable temperature range	-20 ~ +120°C			
SN ratio	50dB or more			
Load resistance	5kΩ or more			
Frequency response of amplifier	DC ~ 1kHz			
Over load	150%			
Mounting thread	M8			
Materials of pressure media	SUS630			
Weight	45g			

Input/Output cable :
 φ3mm 0.08mm² 4-core shielded fluoroplastic cable 5m)

NB: A zero point may drift for a long term con-tinuous use in high temperature.

PRESSURE TRANSDUCERS

PWF-PB Flush Diaphragm type Pressure Transducer

1~50MPa



G3/8 size
High response

Because this transducer has its pressure-receiving surface at the top of mounting screws, it is suitable for use in a situation where pressure changes dynamically. It is widely used to measure the pressure in pipelines, cylinder pressure, and so forth
Protection ratings: IP67 equivalent

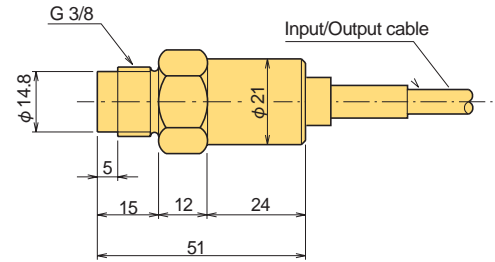
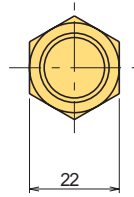

■ SPECIFICATIONS

TYPE	PWF-1MPB	PWF-2MPB	PWF-5MPB	PWF-10MPB	PWF-20MPB	PWF-50MPB
Capacity	1MPa	2MPa	5MPa	10MPa	20MPa	50MPa
Rated Output	1.75mV/V(3500×10 ⁻⁶ strain) ±25%					
Non-linearity	0.5%RO					
Hysteresis	0.5%RO					
Repeatability	0.5%RO					
Temperature effect on zero	0.06%RO/°C					
Temperature effect on span	0.03%/°C					
Compensated temperature range	-10 ~ +60°C					
Allowable temperature range	-20 ~ +70°C					
Over load	150%					
Ultimate overload rating	300%					
Input/Output resistance	350Ω					
Recommended exciting voltage	6V or less					
Allowable exciting voltage	10V					
Natural frequency	30kHz	40kHz	60kHz	80kHz	110kHz	170kHz
Mounting thread	G3/8 (PF3/8)					
Materials of pressure media	SUS630					
Weight	100g					

Input/Output cable :
φ6mm 0.35mm² 4-core shielded chloroprene cable 2m

Applicable fitting torque: 10~20N·m

PWFC-PB Flush Diaphragm type Pressure Transducer

2~50MPa

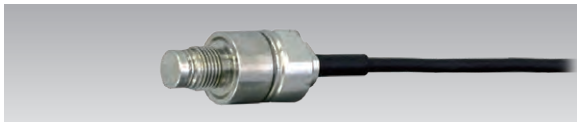

G1/8 size
High response

The PWFC-PB flush diaphragm pressure transducer is small in size and the screw used to mount it is also small G1/8 (PF1/8). The high responsiveness to changes in pressure makes this transducer most suitable for pressure control systems or pressure measurement in a confined space. It is widely used to control pressure in production lines, to measure cylinder pressure, and for many other applications.

Protection ratings: IP67 equivalent

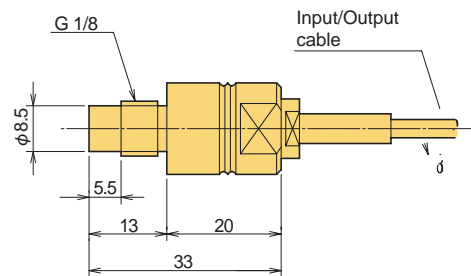
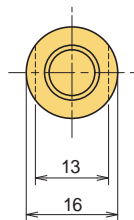

■ SPECIFICATIONS

TYPE	PWFC-2MPB	PWFC-5MPB	PWFC-10MPB	PWFC-20MPB	PWFC-50MPB
Capacity	2MPa	5MPa	10MPa	20MPa	50MPa
Rated Output	1.5mV/V(3000×10 ⁻⁶ strain) ±25%				
Non-linearity	0.5%RO				
Hysteresis	0.5%RO				
Repeatability	0.5%RO				
Temperature effect on zero	0.03%RO/°C				
Temperature effect on span	0.03%/°C				
Compensated temperature range	-10 ~ +60°C				
Allowable temperature range	-20 ~ +70°C				
Over load	150%				
Ultimate overload rating	300%				
Input/Output resistance	350Ω				
Recommended exciting voltage	3V or less				
Allowable exciting voltage	6V				
Natural frequency	70kHz	90kHz	130kHz	180kHz	290kHz
Mounting thread	G1/8 (PF1/8)				
Materials of pressure media	SUS630				
Weight	25g				

Input/Output cable :
φ3mm 0.05mm² 4-core shielded chloroprene cable 2m
Applicable fitting torque: 10~15N·m

PRESSURE TRANSDUCERS

PWFD-PB Flush Diaphragm Pressure Transducer 2~20MPa

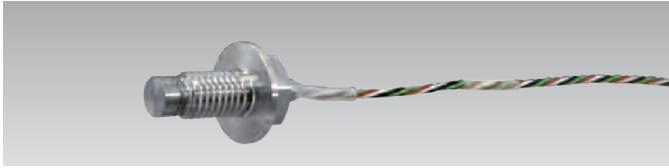

M8 size
High temperature

The PWFD-PB is a bolt-shaped flush diaphragm pressure transducer. As it is small and can be used for dynamic measurement in high temperature region, it suits various pressure measurements around engine. The shape of hexagonal bolt (M8 size) with flange makes installation to a screw hole easy.

Protection ratings: IP67 equivalent

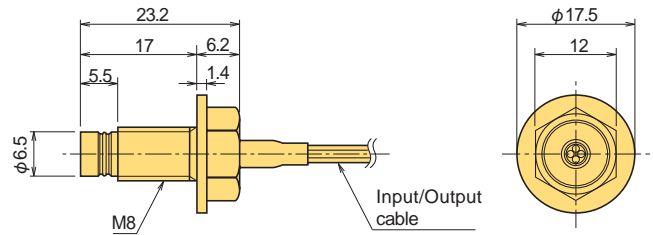

■ SPECIFICATIONS

TYPE	PWFD-2MPB	PWFD-5MPB	PWFD-10MPB	PWFD-20MPB
Capacity	2MPa	5MPa	10MPa	20MPa
Rated Output	1.5mV/V(3000×10 ⁻⁶ strain) ±25%	2mV/V(4000×10 ⁻⁶ strain) ±25%		
Non-linearity	0.5%RO			
Hysteresis	0.5%RO			
Repeatability	0.5%RO			
Temperature effect on zero	0.03%/RO/°C			
Temperature effect on span	0.03%/°C			
Compensated temperature range	0 ~ +150°C			
Allowable temperature range	-20 ~ +150°C			
Over load	150%			
Ultimate overload rating	300%			
Input/Output resistance	350Ω			
Recommended exciting voltage	2V or less			
Allowable exciting voltage	5V			
Natural frequency	70kHz	90kHz	130kHz	180kHz
Mounting thread	M8			
Materials of pressure media	SUS630			
Weight	7g			

Input/Output cable :
0.08mm² 4-core fluoroplastic insulated cable 2m
Applicable fitting torque : 10~15N·m

NB: A zero point may drift for a long term continuous use in high temperature.

PWFE-PA Flush Diaphragm Pressure Transducer 2~20MPa

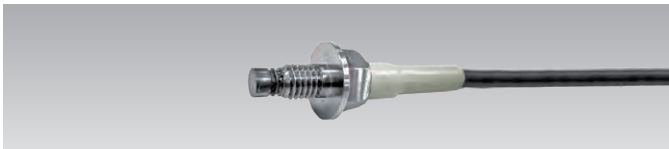

M6 size
High temperature

The PWFE-PA is a bolt-shaped flush diaphragm pressure transducer. As it is small and can be used for dynamic measurement in high temperature region, it suits various pressure measurements around engine. The shape of hexagonal bolt (M6 size) with flange makes installation to a screw hole easy.

Protection ratings: IP67 equivalent

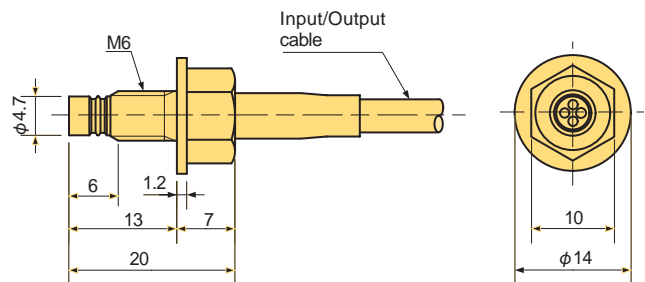

■ SPECIFICATIONS

TYPE	PWFE-2MPA	PWFE-5MPA	PWFE-10MPA	PWFE-20MPA
Capacity	2MPa	5MPa	10MPa	20MPa
Rated Output	1.5mV/V(3000×10 ⁻⁶ strain) ±25%	1.75mV/V(3500×10 ⁻⁶ strain) ±25%		
Non-linearity	1%RO	0.5%RO		
Hysteresis	1%RO	0.5%RO		
Repeatability	0.5%RO			
Temperature effect on zero	0.1%RO/°C			
Temperature effect on span	0.03%/°C			
Compensated temperature range	-20 ~ +150°C			
Allowable temperature range	-20 ~ +150°C			
Over load	120%			
Input/Output resistance	120Ω			
Recommended exciting voltage	2V or less			
Allowable exciting voltage	5V			
Natural frequency	110kHz	160kHz	200kHz	270kHz
Mounting thread	M6			
Materials of pressure media	SUS630			
Weight	5g			

Input/Output cable :
φ4mm 0.08mm² 4-core fluoroplastic insulated cable 2m
Applicable fitting torque : 4~5N·m

NB: A zero point may drift for a long term continuous use in high temperature.

PRESSURE TRANSDUCERS

PDA-PB / PDB-PB Miniature Pressure Transducer 50kPa~3MPa

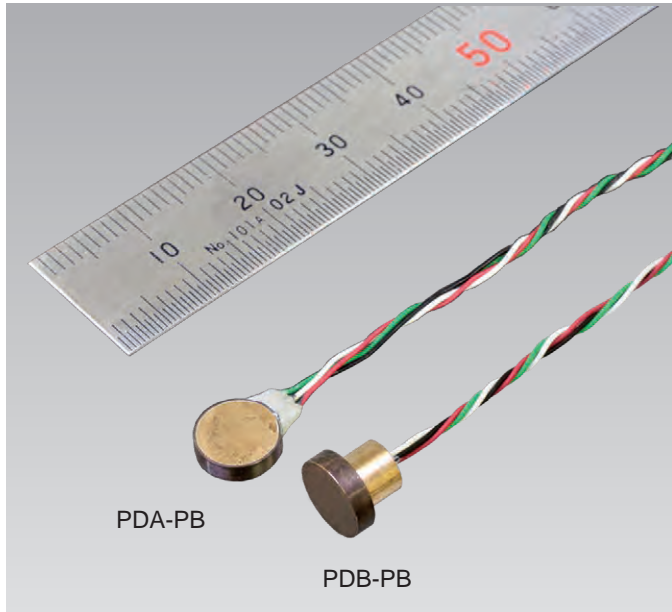

Ultracompact and Lightweight
Waterproof type

PDA-PB

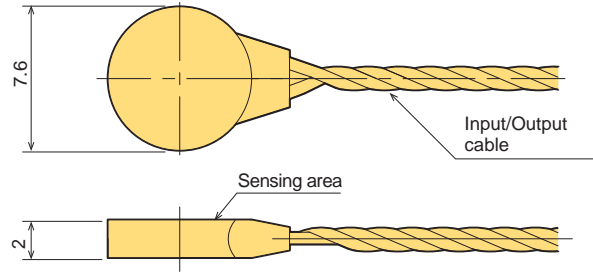

PDB-PB

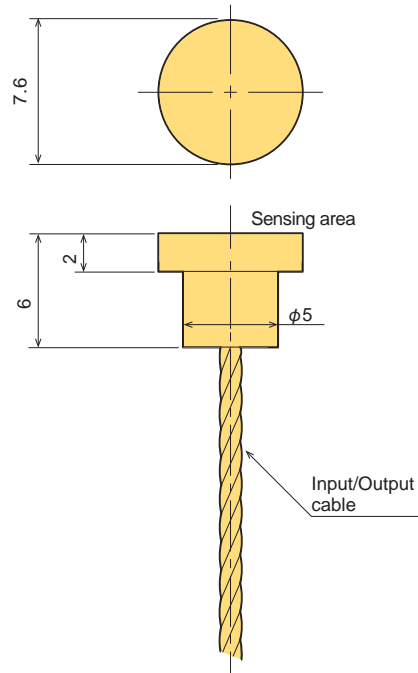

The sensing part of the PDA-PB and PDB-PB miniature pressure gauges is 7.6 mm in diameter and 2 mm in thickness. As they are waterproof for daily ordinary use, they can be used in water. They use a scratch-resistant fluoroplastic insulated cable. Two models of PDA-PB and PDB-PB are available depending on the direction of cable outlet.

Protection ratings: IP67 equivalent

Ultra-miniature, Easy handling

Optimum for model testing

Capable of underwater use for a short term

■ SPECIFICATIONS

TYPE	PDA-50KPB PDB-50KPB	PDA-100KPB PDB-100KPB	PDA-200KPB PDB-200KPB	PDA-500KPB PDB-500KPB	PDA-1MPB PDB-1MPB	PDA-2MPB PDB-2MPB	PDA-3MPB PDB-3MPB
Capacity	50kPa	100kPa	200kPa	500kPa	1MPa	2MPa	3MPa
Rated Output	0.5mV/V (1000x10 ⁻⁶ strain)	0.75mV/V (1500x10 ⁻⁶ strain)	1mV/V(2000x10 ⁻⁶ strain)				
Non-linearity				1%RO			
Hysteresis				1%RO			
Temperature effect on zero				1%RO/°C			
Temperature effect on span				1%/°C			
Compensated temperature range				-10 ~ +60°C (no icing)			
Allowable temperature range				-20 ~ +70°C (no icing)			
Input/Output resistance				350Ω			
Recommended exciting voltage				2V or less			
Allowable exciting voltage				5V			
Weight				PDA-PB: 0.4g PDB-PB: 0.7g			

Input/Output cable : 0.014mm² 4-core cross-linked polyethylene insulated cable 1m

Note: If used in water for a prolonged period, the waterproof performance may deteriorate.

ACCELERATION TRANSDUCERS

TML Acceleration Transducers electrically detect acceleration in all types of structures, including automobiles and machinery. Our acceleration transducers have sensing elements that use TML strain gauges made exclusively for transducers, and they can be used to take measurements based on DC levels.

Example of Frequency characteristics

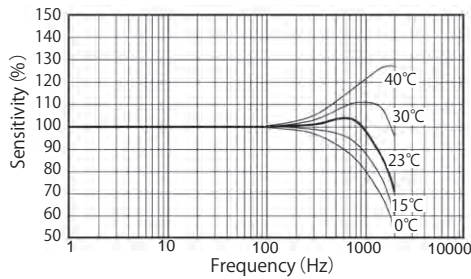

Acceleration transducer presents different frequency characteristics, output sensitivity vs. frequency, depending on temperature.

OUTPUT POLARITY WITH A LOAD

The measured value changes in positive (+) direction when acceleration is applied to the transducer in + direction marked on the transducer.

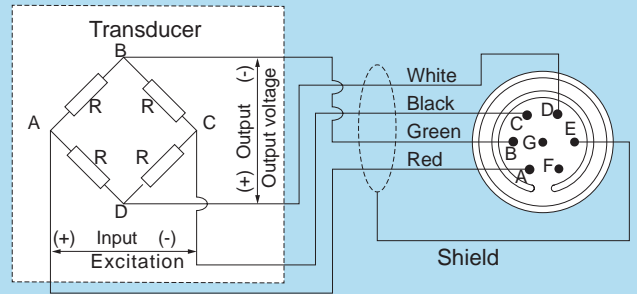

Not applicable to some products.

Acceleration transducer selection

Utility	Type	Capacity (m/s ²)												Page		
		10	20	40	50	100	200	500	1000	2000	5000	10000				
Micromechanical Vibration	Uni-axial model	ARS-A	●													68
Smallest and lightest	Tri-axial model	ARM-A-T	100m/s ² is for X- and Y-directions, 400m/s ² is for Z-direction.												68	
Compact size	Uni-axial model	ARF-A	●	●		●	●	●	●							69
	Tri-axial model	ARF-A-T		●		●	●	●	●							69
Small size and high responsive in the range of high frequencies	Uni-axial model	ARE-A									●	●	●	●	70	
	Tri-axial model	ARE-A-T									●	●	●		70	
Waterproof structure	Uni-axial model	ARH-A	●	●		●	●	●	●						71	
	Uni-axial model	ARJ-A				●	●	●	●	●	●	●			72	
Small size and high responsive characteristics	Bi-axial model	ARJ-A-D				●	●	●	●	●	●	●			72	
	Tri-axial model	ARJ-A-T				●	●	●	●	●	●	●			72	
	Uni-axial model	ARGH-A								●	●	●			73	
Small High response Low capacity	Uni-axial model	ARGL-A		●	●			●	●						73	
Small High response High capacity	Tri-axial model	ARGH-A-T									●				74	
Small High response Low capacity	Tri-axial model	ARGL-A-T						●							75	

HOW TO USE

Vibrating acceleration on vehicle

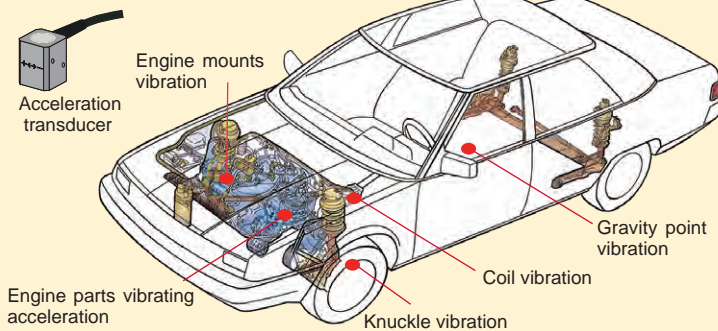

Cable force of cable-stayed bridge

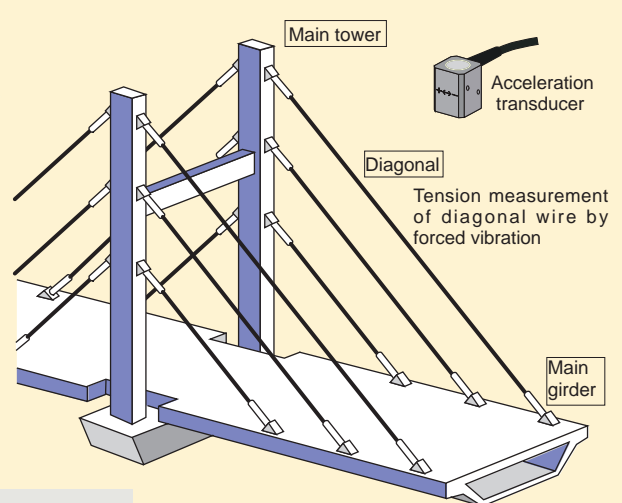

Structure vibrating acceleration

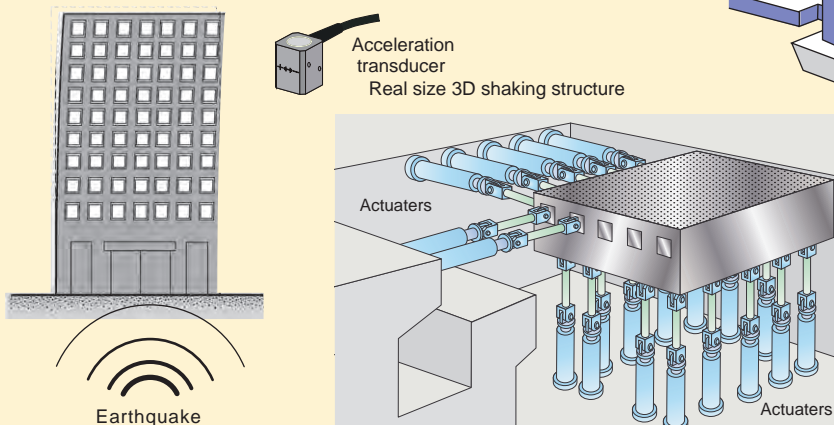

ACCELERATION TRANSDUCERS

ARS-A High sensitive Acceleration Transducer 10m/s²



High sensitivity

Small accelerometer suitable for measurement of vibration mode of machines and structures including cable tension of bridges. High sensitivity of 30000×10^{-6} strain for 10 m/s^2 makes minute vibration measurement possible.

Protection ratings: IP61 equivalent

SPECIFICATIONS

TYPE	ARS-10A
Capacity	10m/s ²
Rated Output	15mV/V (30000×10^{-6} strain)
Non-linearity	1%RO
Frequency response range	DC~30Hz (Sensitivity deviation $\pm 5\%$)
Natural frequency	55Hz
Allowable temperature range	-10 ~ +50°C
Over load	500%
Input/Output resistance	120Ω
Recommended exciting voltage	2V or less
Allowable exciting voltage	5V
Zero balance	$\pm 5000 \times 10^{-6}$ strain or less
Weight	23g

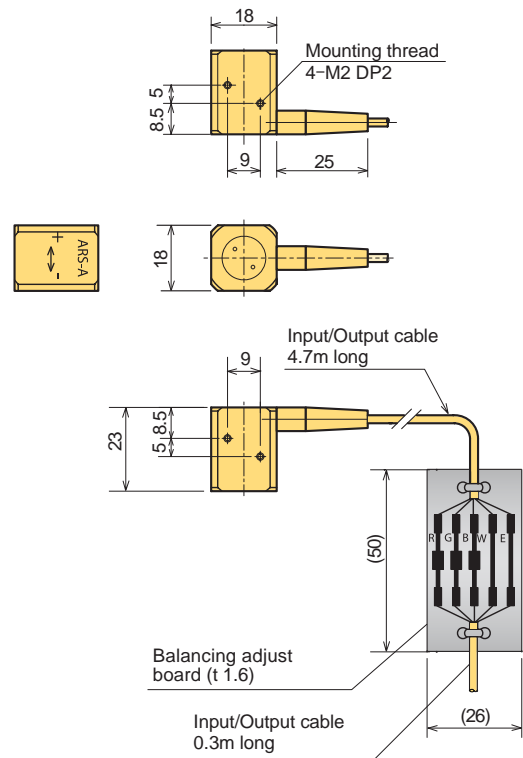

Input/Output cable : $\phi 3.2 \text{ mm}$ 0.08 mm^2 4-core shielded vinyl cable 5m

ARM-A-T Small Tri-axial model Acceleration Transducer 100m/s² / 400m/s²



Identical gravity position for
3 axes
Easy handling

Tri-axial acceleration transducers for the fields of machines, vehicles, shipping, civil works and structures.

Protection ratings: IP61 equivalent

SPECIFICATIONS

TYPE	ARM-A-T
Numbers of measurement	3 directions
Capacity	X- and Y-directions 100m/s ² Z-direction 400m/s ²
Rated output	0.5mV/V (1000×10^{-6} strain)
Non-linearity	1%RO
Frequency response range	DC~200Hz (Sensitivity deviation $\pm 10\%$)
Natural frequency	X- and Y-directions 500Hz Z-direction 1400Hz
Cross sensitivity	3%RO (at 100m/s ² load)
Allowable temperature range	-10 ~ +60°C
Over load	300%
Input/Output resistance	X- and Y-directions 1000Ω Z-direction 200Ω
Recommended exciting voltage	2V or less
Allowable exciting voltage	5V
Weight	13g

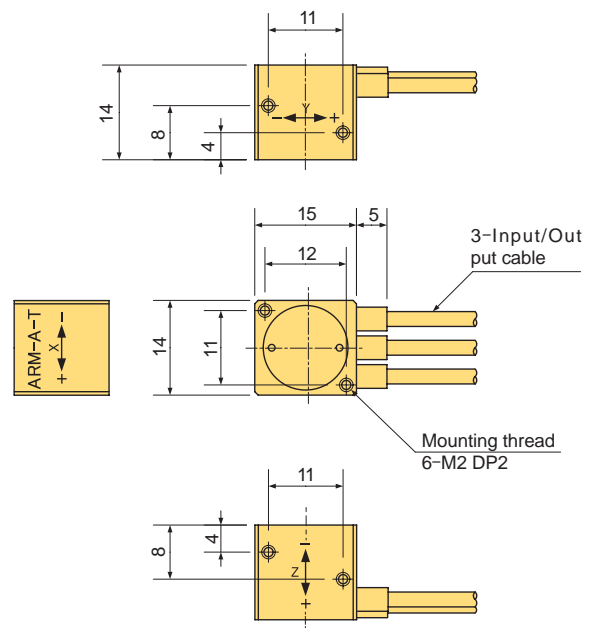

Input/Output cable : $\phi 2.2 \text{ mm}$ 0.05 mm^2 4-core shielded vinyl cable 5m

ACCELERATION TRANSDUCERS

ARF-A Low capacity Acceleration Transducer 10~500m/s²

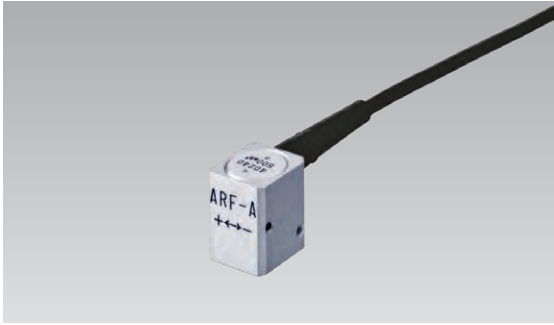

General purpose
Low capacity

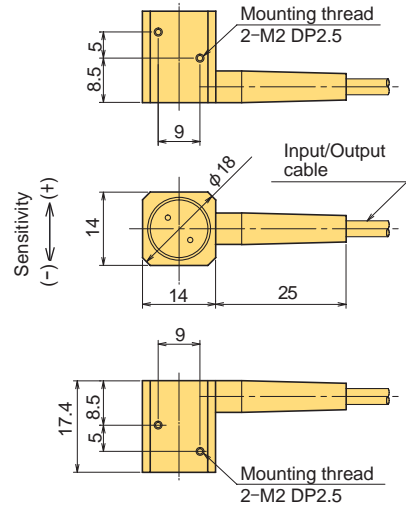

The ARF-A acceleration transducer is used to measure the acceleration of structures subject to vibration such as machinery, vehicles, ships, civil engineering structures, buildings, and so forth. It is small and lightweight and can make measurement on the DC level.

Protection ratings: IP61 equivalent

■ SPECIFICATIONS

TYPE	ARF-10A	ARF-20A	ARF-50A	ARF-100A	ARF-200A	ARF-500A
Capacity	10m/s ²	20m/s ²	50m/s ²	100m/s ²	200m/s ²	500m/s ²
Rated Output	0.5mV/V(1000x10 ⁻⁶ strain)					
Non-linearity	1%RO					
Frequency response range (※)	DC~50Hz	DC~80Hz	DC~130Hz	DC~180Hz	DC~310Hz	DC~520Hz
Natural frequency	100Hz	150Hz	240Hz	300Hz	520Hz	870Hz
Allowable temperature range	-10 ~ +50°C					
Over load	300%					
Input/Output resistance	120Ω					
Recommended exciting voltage	2V or less					
Allowable exciting voltage	5V					
Weight	13g					

※Sensitivity deviation ±5%

Input/Output cable : φ3.2mm 0.08mm² 4-core shielded vinyl cable 5m Shield of Input/Output cable is grounded to the body.

ARF-A-T Low capacity Tri-axial Acceleration Transducer 20~500m/s²



General-purpose
Low capacity
Three directional measurement

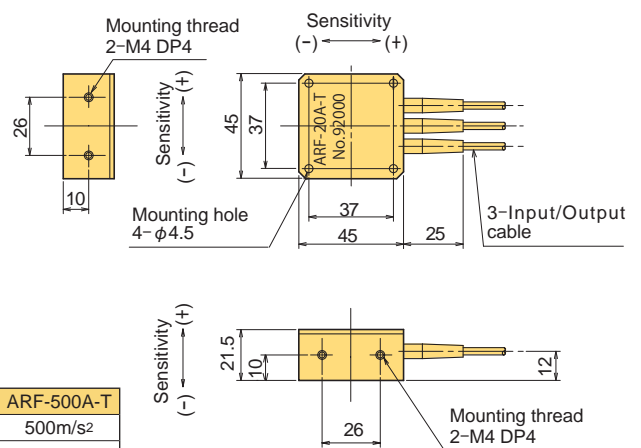

The ARF-A-T acceleration transducer measures acceleration in three directions (X, Y and Z) simultaneously. It is small and lightweight and can make high-accuracy measurement with the least interference.

Protection ratings: IP61 equivalent

■ SPECIFICATIONS

TYPE	ARF-20A-T	ARF-50A-T	ARF-100A-T	ARF-200A-T	ARF-500A-T
Capacity	20m/s ²	50m/s ²	100m/s ²	200m/s ²	500m/s ²
Rated Output	0.5mV/V(1000x10 ⁻⁶ strain)				
Non-linearity	1%RO				
Frequency response range (※)	DC~80Hz	DC~130Hz	DC~180Hz	DC~310Hz	DC~520Hz
Natural frequency	150Hz	240Hz	300Hz	520Hz	870Hz
Cross sensitivity	3%RO				
Allowable temperature range	-10 ~ +50°C				
Over load	300%				
Input/Output resistance	120Ω				
Recommended exciting voltage	2V or less				
Allowable exciting voltage	5V				
Weight	85g				

※Sensitivity deviation ±10%

Input/Output cable : φ3.2mm 0.08mm² 4-core shielded vinyl cable 5m Shield of Input/Output cable is grounded to the body.

ACCELERATION TRANSDUCERS

ARE-A High capacity Acceleration Transducer 1000~10000m/s²



General purpose
High capacity

The ARE-A acceleration transducer is used to measure the acceleration of structures subject to relatively strong vibration. It is small, lightweight and easy to operate.

Protection ratings: IP61 equivalent

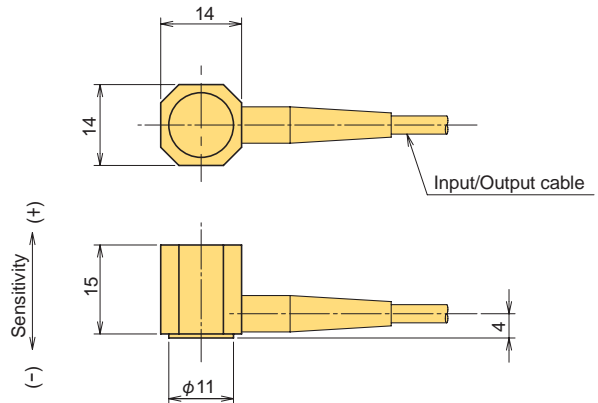

■ SPECIFICATIONS

TYPE	ARE-1000A	ARE-2000A	ARE-5000A	ARE-10000A
Capacity	1000m/s ²	2000m/s ²	5000m/s ²	10000m/s ²
Rated Output	0.5mV/V/(1000×10 ⁻⁶ strain)			
Non-linearity	1%RO			
Frequency response range	DC~1.3kHz*1	DC~2.1kHz*1	DC~2.1kHz*1	DC~5kHz*2
Natural frequency	2.2kHz	3.5kHz	4.5kHz	7.5kHz
Allowable temperature range	-10 ~ +50°C		-10 ~ +60°C	
Over load	300%			
Input/Output resistance	120Ω			
Recommended exciting voltage	2V or less			
Allowable exciting voltage	5V			
Weight	8g			

*1 : Sensitivity deviation ±5% *2 : Sensitivity deviation ±10%
Input/Output cable : φ 3.2mm 0.08mm² 4-core shielded vinyl cable 5m
Shield of Input/Output cable is grounded to the body.

ARE-A-T High capacity Tri-axial Acceleration Transducer 1000~5000m/s²



General purpose
High capacity
Three directional measurement

The ARE-A-T acceleration transducer measures acceleration in three directions (X, Y and Z) simultaneously. It is small and lightweight and can make high-accuracy measurement with the least interference.

Protection ratings: IP61 equivalent

■ SPECIFICATIONS

TYPE	ARE-1000A-T	ARE-2000A-T	ARE-5000A-T
Capacity	1000m/s ²	2000m/s ²	5000m/s ²
Rated Output	0.5mV/V/(1000×10 ⁻⁶ strain)		
Non-linearity	1%RO		
Frequency response range (*)	DC~1.3kHz	DC~2.1kHz	DC~2.1kHz
Natural frequency	2.2kHz	3.5kHz	4.5kHz
Cross sensitivity	3%RO		
Allowable temperature range	-10 ~ +50°C		-10 ~ +60°C
Over load	300%		
Input/Output resistance	120Ω		
Recommended exciting voltage	2V or less		
Allowable exciting voltage	5V		
Weight	77g	77g	75g

* Sensitivity deviation ±5%
Input/Output cable : φ 3.2mm 0.08mm² 4-core shielded vinyl cable 5m
Shield of Input/Output cable is grounded to the body.

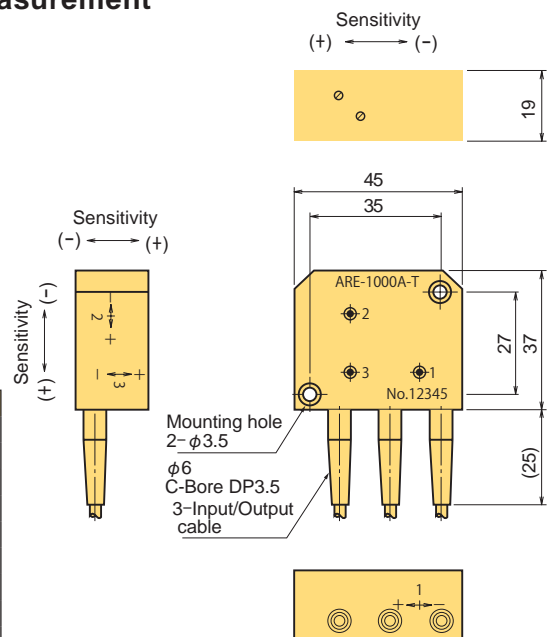

ACCELERATION TRANSDUCERS

ARH-A Waterproof, Low capacity Acceleration Transducer 10~500m/s²



Waterproof type
Low capacity

The ARH-A acceleration transducer has a waterproof structure. It is installed in water or ground or embedded in concrete. The rigid waterproof structure makes this transducer suitable for use in an adverse environment or for outdoor use.

Protection ratings: IP67 equivalent

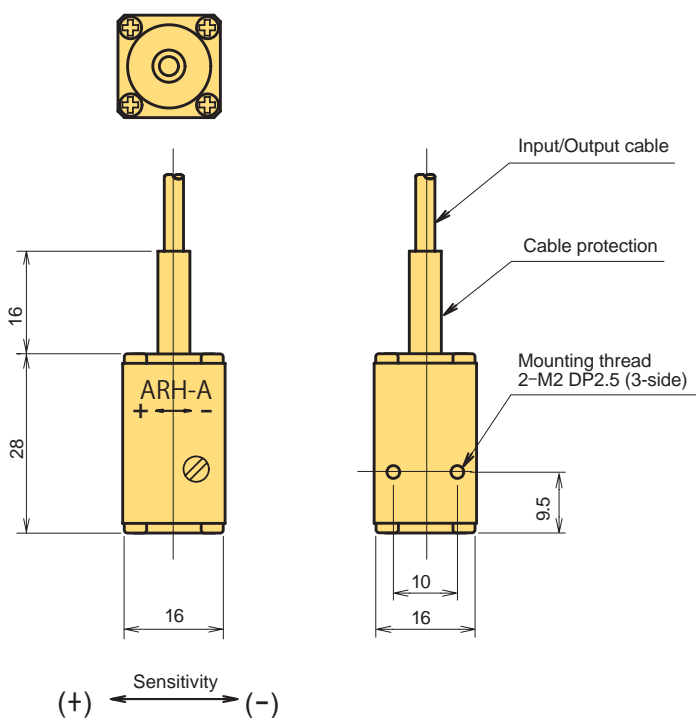

■ SPECIFICATIONS

TYPE	ARH-10A	ARH-20A	ARH-50A	ARH-100A	ARH-200A	ARH-500A
Capacity	10m/s ²	20m/s ²	50m/s ²	100m/s ²	200m/s ²	500m/s ²
Rated Output	0.5mV/V(1000×10 ⁻⁶ strain)					
Non-linearity	1%RO					
Frequency response range (※)	DC~50Hz	DC~80Hz	DC~130Hz	DC~180Hz	DC~310Hz	DC~520Hz
Natural frequency	100Hz	150Hz	240Hz	300Hz	520Hz	870Hz
Allowable temperature range	-10 ~ +50°C					
Over load	300%					
Input/Output resistance	120Ω					
Recommended exciting voltage	2V or less					
Allowable exciting voltage	5V					
Water pressure resistive	500kPa					
Weight	18g					

※ Sensitivity deviation ±5%

Input/Output cable : φ3.2mm 0.08mm² 4-core shielded vinyl cable 5m Shield of Input/Output cable is grounded to the body.

ACCELERATION TRANSDUCERS

ARJ series Acceleration Transducer 50~2000m/s²

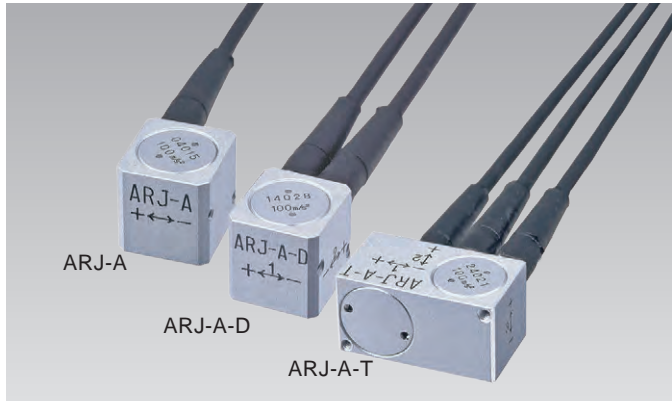

The ARJ series acceleration transducer is small in size and has highly responsive characteristics. This series is developed to measure the acceleration of machinery, vehicles, ships, civil engineering structures, buildings, and so forth. And the series consists of uni-axial model ARJ-A, bi-axial model ARJ-A-D with the same size and weight as the uni-axial model, and tri-axial model ARJ-A-T with the same height as the uni-, bi-axial models and weighs times double of the bi-axial model.

Protection ratings: IP61 equivalent

ARJ-A

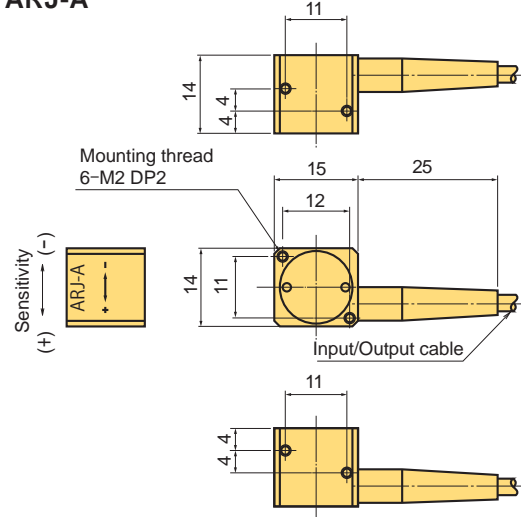

ARJ-A-T

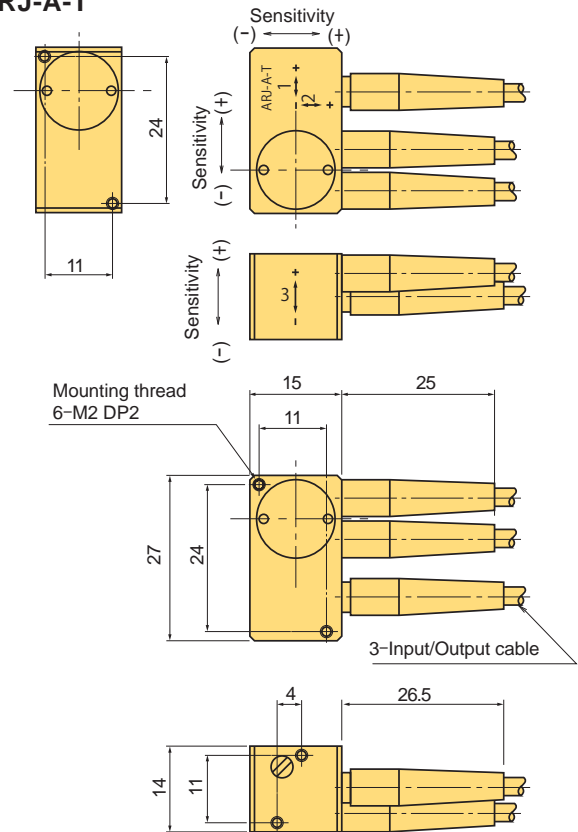

ARJ-A-D

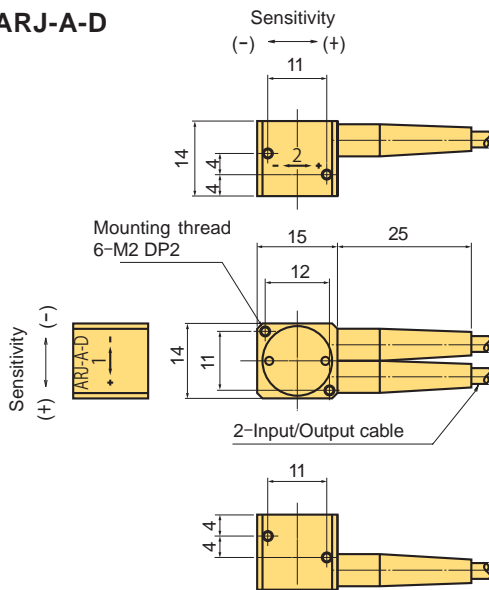

SPECIFICATIONS

TYPE	Uni-axial Bi-axial Tri-axial	ARJ-50A ARJ-50A-D ARJ-50A-T	ARJ-100A ARJ-100A-D ARJ-100A-T	ARJ-200A ARJ-200A-D ARJ-200A-T	ARJ-500A ARJ-500A-D ARJ-500A-T	ARJ-1000A ARJ-1000A-D ARJ-1000A-T	ARJ-2000A ARJ-2000A-D ARJ-2000A-T
Capacity		50m/s ²	100m/s ²	200m/s ²	500m/s ²	1000m/s ²	2000m/s ²
Rated Output		0.5mV/V(1000x10 ⁻⁶ strain)					
Non-linearity		1%RO					
Frequency response range (※)		DC~150Hz	DC~300Hz	DC~500Hz	DC~780Hz	DC~1kHz	DC~2kHz
Natural frequency		280Hz	500Hz	830Hz	1kHz	2kHz	3kHz
Cross sensitivity		3%RO (except uni-axial model ARJ-A)					
Allowable temperature range		-10 ~ +60°C	-10 ~ +50°C				
Over load		300%					
Input/Output resistance		Approx. 1kΩ					
Recommended exciting voltage		5V or less					
Allowable exciting voltage		15V					
Weight	Uni-axial	13g	12g	12g	10g	11g	11g
	Bi-axial	14g	13g	13g	11g	12g	12g
	Tri-axial	27g	25g	24g	20g	22g	22g

※ Sensitivity deviation ±5%

Input/Output cable : φ 3.2mm 0.08mm² 4-core shielded vinyl cable 5m Shield of Input/Output cable is grounded to the body.

ACCELERATION TRANSDUCERS

ARGH-A Small, High response, High capacity Acceleration Transducer 500~2000m/s² **NEW**



MEMS-based acceleration transducer compatible with DC-exciting dynamic strain meter

The ARGH-A is a small and high-response acceleration transducer incorporating a MEMS-based acceleration sensor. Its small, light-weight and robust structure allows the use of this transducer for the measurement in various fields such as machines, vehicles, ships, civil engineering and construction. This transducer can easily be used by merely connecting it to our dc-exciting dynamic strain meter without using an external power supply. Protection ratings: IP61 equivalent

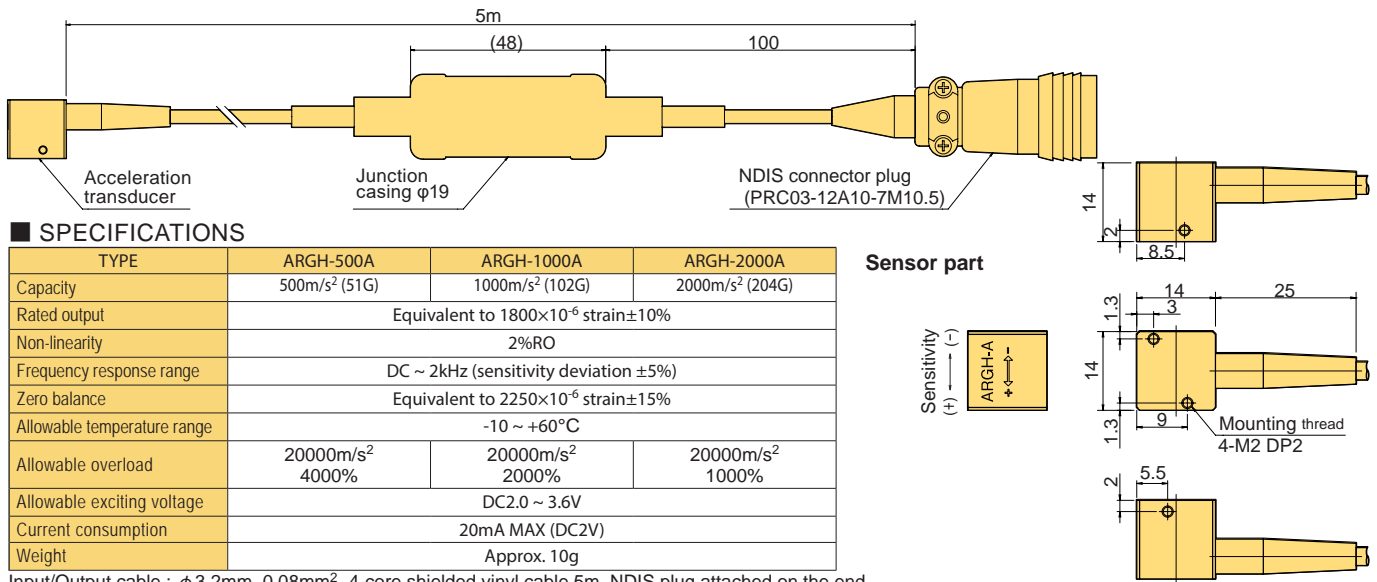

■ SPECIFICATIONS

TYPE	ARGH-500A	ARGH-1000A	ARGH-2000A
Capacity	500m/s ² (51G)	1000m/s ² (102G)	2000m/s ² (204G)
Rated output	Equivalent to 1800×10 ⁻⁶ strain±10%		
Non-linearity	2%RO		
Frequency response range	DC ~ 2kHz (sensitivity deviation ±5%)		
Zero balance	Equivalent to 2250×10 ⁻⁶ strain±15%		
Allowable temperature range	-10 ~ +60°C		
Allowable overload	20000m/s ² 4000%	20000m/s ² 2000%	20000m/s ² 1000%
Allowable exciting voltage	DC2.0 ~ 3.6V		
Current consumption	20mA MAX (DC2V)		
Weight	Approx. 10g		

Input/Output cable : φ3.2mm 0.08mm² 4-core shielded vinyl cable 5m, NDIS plug attached on the end

ARGL-A Small, High response, Low capacity Acceleration Transducer 20~200m/s² **NEW**



MEMS-based acceleration transducer compatible with DC-exciting dynamic strain meter

The ARGL-A is a small and high-response acceleration transducer incorporating a MEMS-based acceleration sensor. Its small, light-weight and robust structure allows the use of this transducer for the measurement in various fields such as machines, vehicles, ships, civil engineering and construction. This transducer can easily be used by merely connecting it to our dc-exciting dynamic strain meter without using an external power supply. Protection ratings: IP61 equivalent

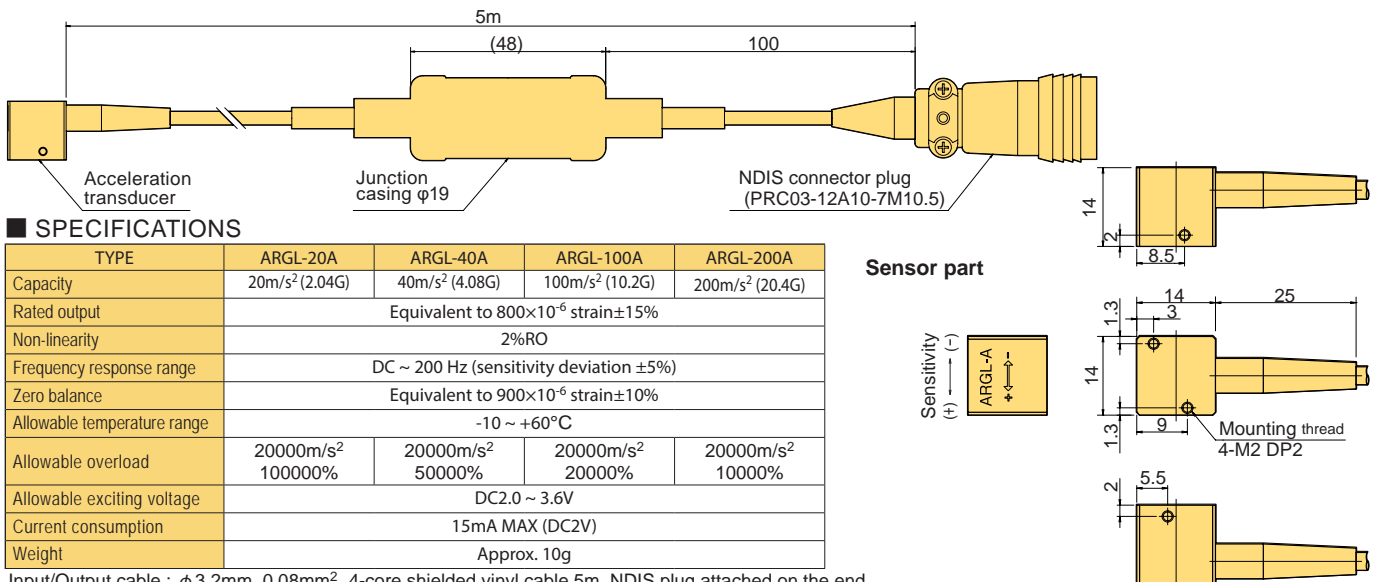

■ SPECIFICATIONS

TYPE	ARGL-20A	ARGL-40A	ARGL-100A	ARGL-200A
Capacity	20m/s ² (2.04G)	40m/s ² (4.08G)	100m/s ² (10.2G)	200m/s ² (20.4G)
Rated output	Equivalent to 800×10 ⁻⁶ strain±15%			
Non-linearity	2%RO			
Frequency response range	DC ~ 200 Hz (sensitivity deviation ±5%)			
Zero balance	Equivalent to 900×10 ⁻⁶ strain±10%			
Allowable temperature range	-10 ~ +60°C			
Allowable overload	20000m/s ² 100000%	20000m/s ² 50000%	20000m/s ² 20000%	20000m/s ² 10000%
Allowable exciting voltage	DC2.0 ~ 3.6V			
Current consumption	15mA MAX (DC2V)			
Weight	Approx. 10g			

Input/Output cable : φ3.2mm 0.08mm² 4-core shielded vinyl cable 5m, NDIS plug attached on the end

ACCELERATION TRANSDUCERS

ARGL-A-T Small, High response, Low capacity, Tri-axial Acceleration Transducer 100m/s^2 **NEW**



Same shape as single-axis type
Capable of measuring in three directions

The ARGL-A-T is a small and high-response acceleration transducer incorporating a MEMS-based acceleration sensor. Its small, light-weight and robust structure allows the use of this transducer for the measurement in various fields such as machines, vehicles, ships, civil engineering and construction. This transducer can be just connected to our dc-exciting dynamic strain meter and measured without the need of an external power supply.

Protection ratings: IP61 equivalent

Acceleration transducer

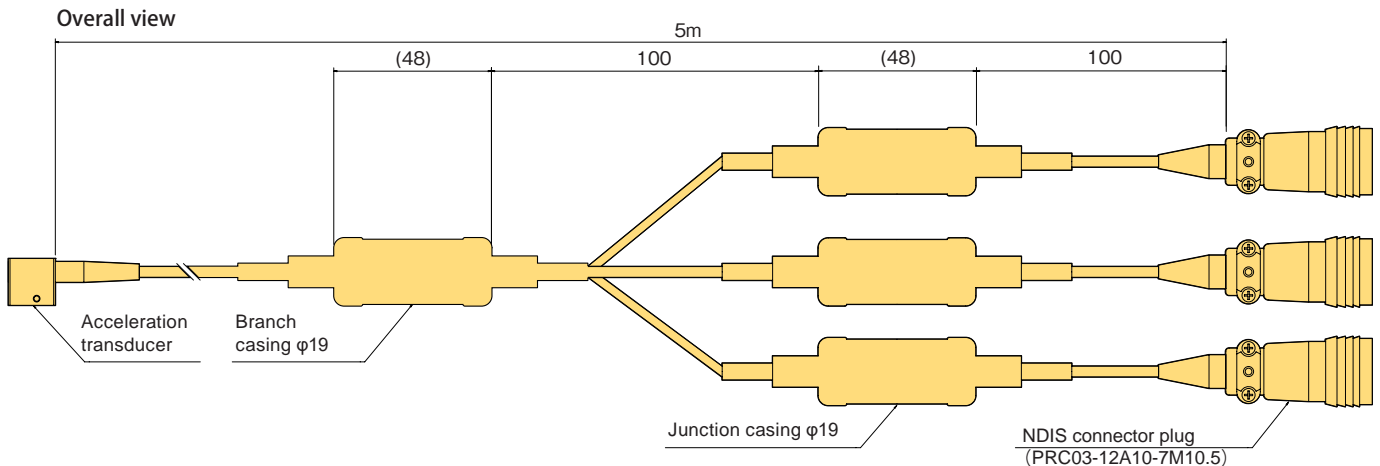
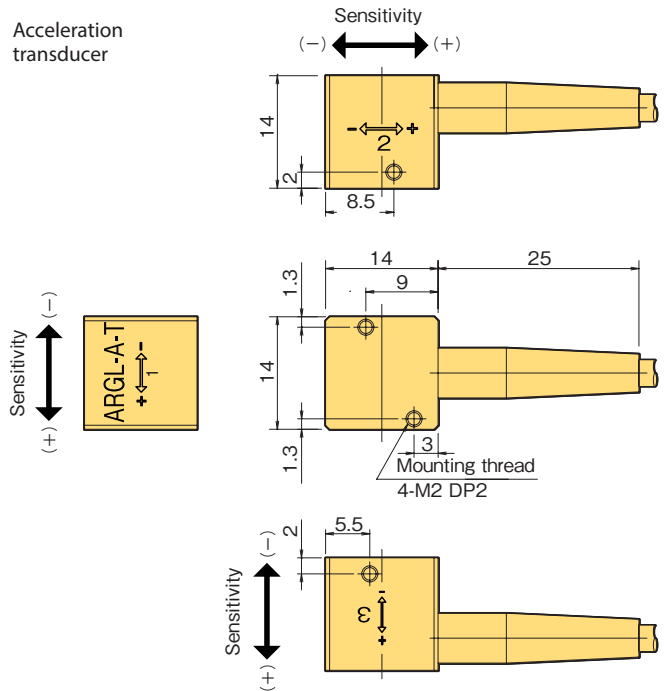

SPECIFICATIONS

TYPE	ARGL-100A-T
Number of measurement axis	3-axis
Capacity	100 m/s^2 (10.2 G)
Rated output	Equivalent to 800×10^{-6} strain $\pm 15\%$
Non-linearity	2%RO
Frequency response range	DC ~ 200 Hz (sensitivity deviation $\pm 5\%$)
Cross sensitivity	5%RO
Zero balance	Equivalent to 900×10^{-6} strain $\pm 10\%$
Allowable temperature range	$-10 \sim +60^\circ\text{C}$
Allowable overload	20000 m/s^2
Allowable exciting voltage	DC 2.0 ~ 3.6 V
Current consumption	15 mA MAX. (DC 2 V)
Weight	Approx. 10 g

Input/Output cable : $\phi 3.2\text{mm}$ 0.08mm^2 4-core shielded vinyl cable 5m, NDIS plug attached on the end.
The zero balance is the output at no load and depends on the condition of the measuring instrument.
TMR-321, DC-204R and DC-204Ra accept the use of a remote sensing cable (CR-6184).

Acceleration transducers accessories

Mounting plate

There are 5 kinds of mounting plates to suit the following acceleration transducers.
Six pieces of the fixing bolt M2x5mm are supplied for each mounting plate.

Mounting plate	Applicable transducers	Mount faces	Dimension
ARJF-11	<ul style="list-style-type: none"> •ARJ-A •ARJ-A-D •ARJ-A-T •ARM-A-T •ARK-A 	Side/Bottom Side/Bottom Side Side/Bottom Side/Bottom	
ARFF-11	•ARF-A	Side	
ARFF-12	•ARF-A x 3	Tri-axial mounting	
ARHF-11	•ARH-A	Side	
ARJF-12	•ARJ-A-T	Bottom	
ARSF-11	•ARS-A	Side	

TRANSDUCER OUTPUT POLARITY

Our standard transducers are designed with the following output polarity for measurement.

Displacement Transducer CDP, SDP

Measuring rod is depressed on measurement, output turns minus polarity.

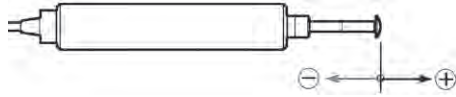

Displacement Transducer DP

Measuring wire is taken out on measurement, output turns plus polarity.

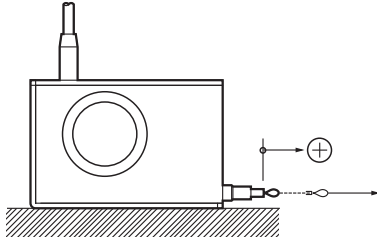

Displacement Transducer OU

Measuring contact tip is depressed on measurement, output turns minus polarity.

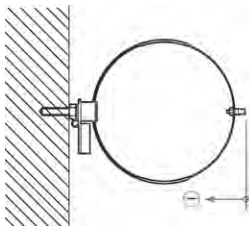

Displacement Transducer CE

Measuring contact tip is depressed on measurement, output turns minus polarity.

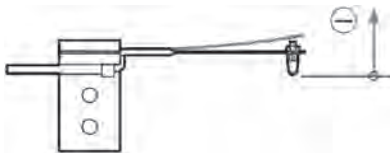

Pressure Transducer PW

Pressure is loaded, output turns plus polarity.

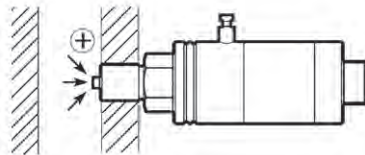

Load Cells

Compressive force is loaded, output turns minus polarity, while tensile force is loaded, output turns plus polarity.

N.B.:

The measured value of the KCK-NA and KCH-NA load cell shows "+" polarity with increase in compression load.

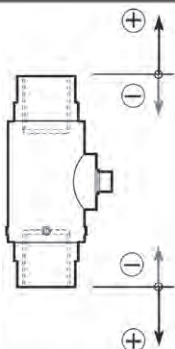

Displacement Transducer PI

Crack opening develops, output turns plus polarity.

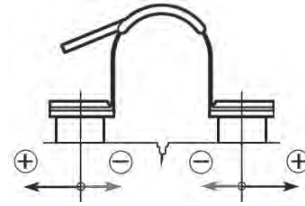

Crack Displacement Gauge KG

Crack opening develops, output turns plus polarity.

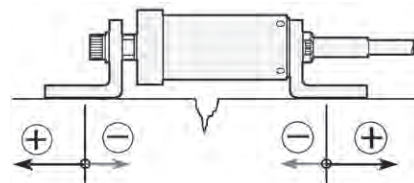

Ground Extension Gauge KLG/NKLG

Super-invar wire is extended on measurement, output turns plus polarity.

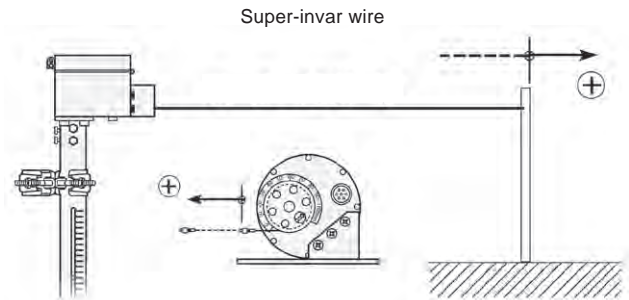

Soil Pressure Gauge KDA - KDL

Pressure is loaded, output turns plus polarity.

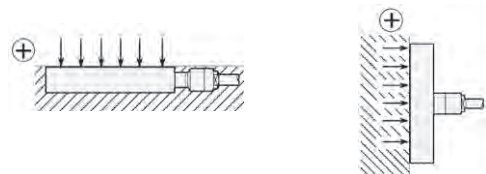

Settlement Transducer KLA/NKLA

Rod (KLF-21) between the transducer KLA/NKLA and a hydraulic anchor shrinks due to settlement, output turns plus polarity.

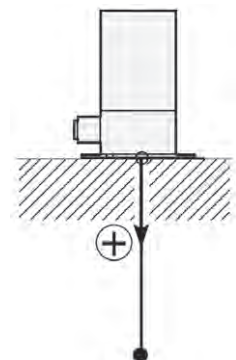

Soil pressure at construction site

KDA-PA/KDB-PA Soil Pressure Gauge

Civil engineering design



The KDA-PA and KDB-PA are soil pressure gauges each 200 mm in outside diameter. They are widely used at construction sites. They are designed with a dual-diaphragm structure that can minimize the displacement of a sensing area and thereby can keep the stress distribution in soil undisturbed under pressure. The KDA-PA is used to measure the pressure in soil and to monitor the behavior of embankments. The KDB-PA is used to measure the pressure in earth retaining walls or the pressure on wall surfaces of structures.

Protection ratings: IP68 equivalent

Minute displacement of pressure-sensitive area due to dual-diaphragm structure
Can measure dynamic earth pressure, too

■ SPECIFICATIONS

TYPE	KDA-200KPA KDB-200KPA	KDA-500KPA KDB-500KPA	KDA-1MPA KDB-1MPA	KDA-2MPA KDB-2MPA
Capacity	200kPa	500kPa	1MPa	2MPa
Rated Output	1mV/V(2000×10 ⁻⁶ strain)			
Non-linearity	2%RO	1%RO		
Allowable temperature range	-20 ~ +60°C			
Input/Output resistance	350Ω			
Recommended exciting voltage	3V or less			
Allowable exciting voltage	10V			
Cable drawing direction	KDA-PA: from side of body		KDB-PA: from back of body	
Weight	6 kg			

KDA-PA

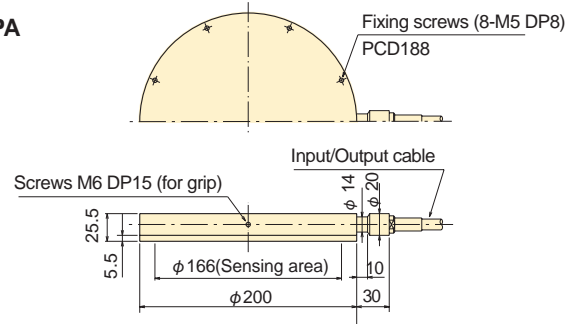

KDB-PA

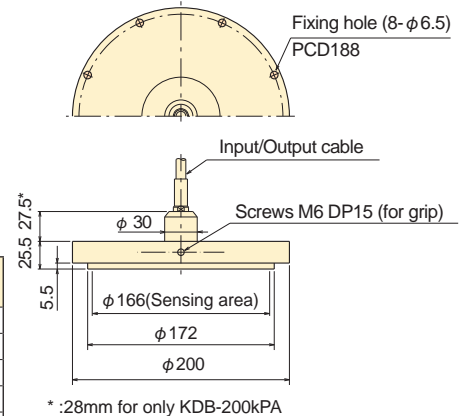

Input/Output cable :
 φ9mm 0.5mm² 4-core shielded chloroprene cable 2m

KDC-PA/KDD-PA Soil Pressure Gauge

Civil engineering design



The KDC-PA and KDD-PA are anticorrosion stainless-steel soil pressure gauges each 100 mm in outside diameter. They are used to measure the pressure in soil in ocean or coastal civil engineering structures and to measure the dynamic pressure of waves. The difference between these two models is the way the cable is attached to the gauge body.

Protection ratings: IP68 equivalent

Made of all stainless steel with excellent corrosion resistance

Minute displacement of pressure-sensitive area due to dual-diaphragm structure
Can measure dynamic earth pressure, too

■ SPECIFICATIONS

TYPE	KDC-200KPA KDD-200KPA	KDC-500KPA KDD-500KPA	KDC-1MPA KDD-1MPA	KDC-2MPA KDD-2MPA
Capacity	200kPa	500kPa	1MPa	2MPa
Rated Output	1mV/V(2000×10 ⁻⁶ strain)			
Non-linearity	2%RO	1%RO		
Allowable temperature range	-20 ~ +60°C			
Input/Output resistance	350Ω			
Recommended exciting voltage	3V or less			
Allowable exciting voltage	10V			
Cable drawing direction	KDC-PA: from side of body		KDD-PA: from back of body	
Weight	1.2 kg			

KDC-PA

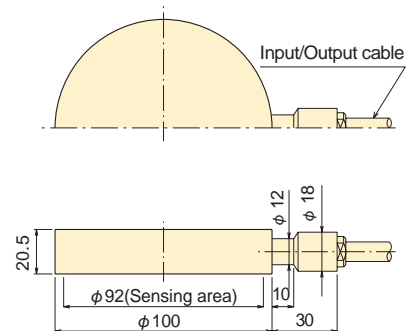

KDD-PA

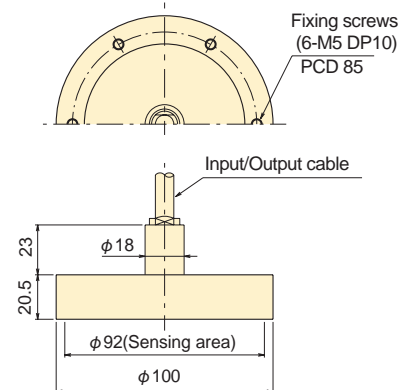

Input/Output cable :
 φ9mm 0.5mm² 4-core shielded chloroprene cable 2m

Soil pressure at construction site

KDE-PA/KDF-PA Soil Pressure Gauge

Civil engineering design

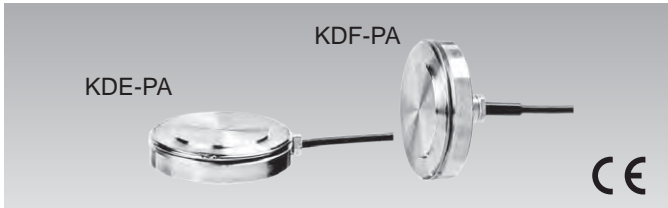

The KDE-PA and KDF-PA are soil pressure gauges each 50 mm in outside diameter. They are small in size and have a dual diaphragm structure, so they are widely used to conduct model experiments. The difference between these two models is the way the cable is attached to the gauge body.

Protection ratings: IP68 equivalent

Made of all stainless steel with excellent corrosion resistance

Minute displacement of pressure-sensitive area due to dual-diaphragm structure

Can measure dynamic earth pressure, too

SPECIFICATIONS

TYPE	KDE-200KPA KDF-200KPA	KDE-500KPA KDF-500KPA	KDE-1MPA KDF-1MPA	KDE-2MPA KDF-2MPA
Capacity	200kPa	500kPa	1MPa	2MPa
Rated Output	0.3mV/V (600×10 ⁻⁶ strain)	0.5mV/V(1000×10 ⁻⁶ strain)		
Non-linearity	2%RO			
Allowable temperature range	-20 ~ +60°C			
Input/Output resistance	350Ω			
Recommended exciting voltage	3V or less			
Allowable exciting voltage	10V			
Cable drawing direction	KDE-PA: from side of body		KDF-PA: from back of body	
Weight	160 g			

KDE-PA

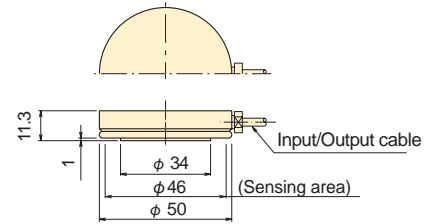

KDF-PA

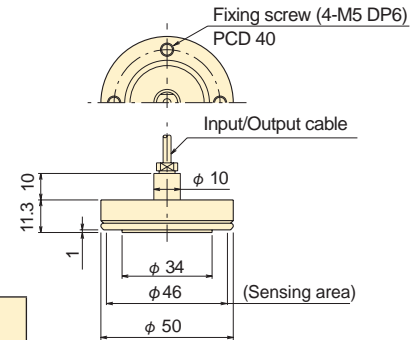

Input/Output cable :
φ 3mm 0.05mm² 4-core shielded chloroprene cable 2m

KDG-PA/KDH-PA Load Cell type Soil Pressure Gauge

Civil engineering design



The KDG-PA and KDH-PA are stainless-steel soil pressure gauges each 100 mm in outside diameter. They are load-cell-type soil pressure gauges and designed with a high level of resistance to lateral pressure. The difference between these two models is the way the cable is attached to the gauge body.

Protection ratings: IP68 equivalent

Made of all stainless steel with excellent corrosion resistance

Robuster than the diaphragm type

SPECIFICATIONS

TYPE	KDG-200KPA KDH-200KPA	KDG-500KPA KDH-500KPA	KDG-1MPA KDH-1MPA	KDG-2MPA KDH-2MPA
Capacity	200kPa	500kPa	1MPa	2MPa
Rated Output	1mV/V(2000×10 ⁻⁶ strain)			
Non-linearity	1%RO			
Allowable temperature range	-20 ~ +60°C			
Input/Output resistance	350Ω			
Recommended exciting voltage	3V or less			
Allowable exciting voltage	10V			
Cable drawing direction	KDG-PA: from side of body		KDH-PA: from back of body	
Weight	1.2 kg			

KDG-PA

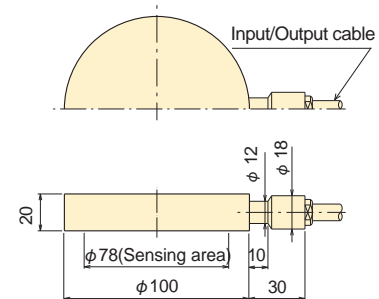

KDH-PA

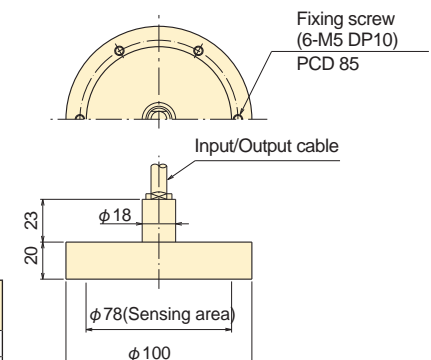

Input/Output cable :
φ 9mm 0.5mm² 4-core shielded chloroprene cable 2m

Soil pressure at construction site

KDJ-PA/KDK-PA Load Cell type Soil Pressure Gauge

Civil engineering design

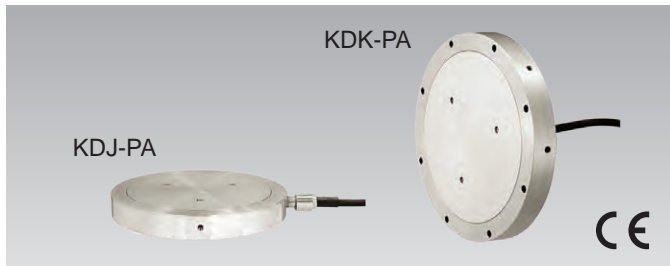

The KDJ-PA and KDK-PA are stainless-steel soil pressure gauges each 200 mm in outside diameter. They are load-cell-type soil pressure gauges and designed with a high level of resistance to lateral pressure. The difference between these two models is the way the cable is attached to the gauge body.

Protection ratings: IP68 equivalent

Made of all stainless steel with excellent corrosion resistance

Robuster than the diaphragm type

SPECIFICATIONS

TYPE	KDJ-200KPA KDK-200KPA	KDJ-500KPA KDK-500KPA	KDJ-1MPA KDK-1MPA	KDJ-2MPA KDK-2MPA
Capacity	200kPa	500kPa	1MPa	2MPa
Rated Output	1mV/V(2000x10 ⁻⁶ strain)			
Non-linearity	1%RO			
Allowable temperature range	-20 ~ +60°C			
Input/Output resistance	350Ω			
Recommended exciting voltage	3V or less			
Allowable exciting voltage	10V			
Cable drawing direction	KDJ-PA: from side of body		KDK-PA: from back of body	
Weight	5.2 kg			

KDJ-PA

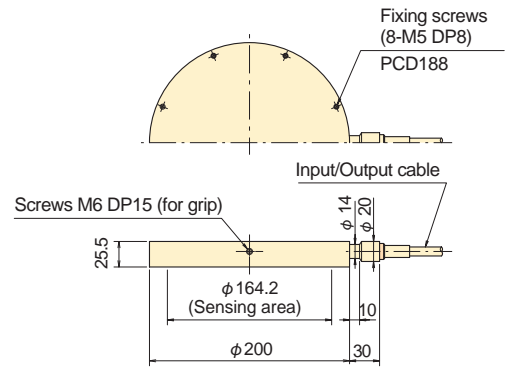

KDK-PA

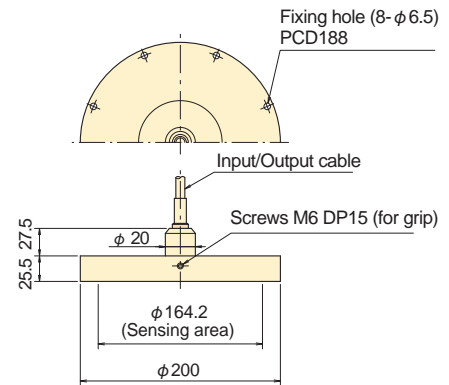

Input/Output cable :
φ 9mm 0.5mm² 4-core shielded chloroprene cable 2m

Pore water pressure in ground

KPC-PA/KPD-PA Pore Pressure Gauge

Civil engineering design

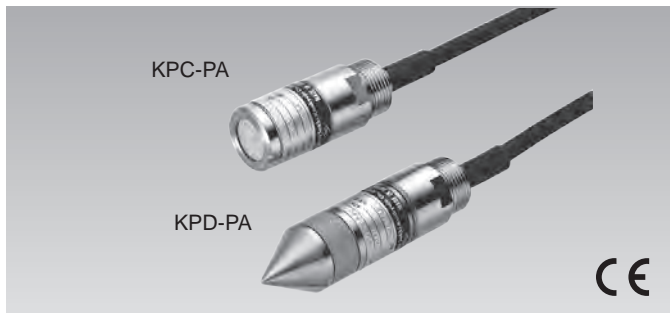

These pressure gauges, which are one size smaller than the KPA-PA and KPB-PA, are used to measure pore water pressure in soil, sheet piles, piles and boreholes. The KPC-PA is attached to a pile, a diaphragm wall, a sheet pile, etc., and buried in ground to measure pore water pressure. The KPD-PA is buried in a borehole to measure pore water pressure in bedrock.

Protection ratings: IP68 equivalent

SPECIFICATIONS

TYPE	KPC-200KPA KPD-200KPA	KPC-500KPA KPD-500KPA	KPC-1MPA KPD-1MPA	KPC-2MPA KPD-2MPA
Capacity	200kPa	500kPa	1MPa	2MPa
Rated output	0.8mV/V (1600x10 ⁻⁶ strain)	1mV/V (2000x10 ⁻⁶ strain)		
Non-linearity	1.5%RO	1%RO		
Outer diameter	φ 30mm			
Filter mesh	40μm(*)			
Allowable temperature range	0 ~ +60°C (No icing)			
Input/Output resistance	350Ω			
Recommended exciting voltage	3V or less			
Allowable exciting voltage	10V			
Weight	KPC-200KPA ~ KPC-2MPA 250 g		KPD-200KPA ~ KPD-2MPA 350 g	

Dual structure not affected by the outer lateral pressure

Made of all stainless steel with excellent corrosion resistance
Small, easy handling

KPC-PA

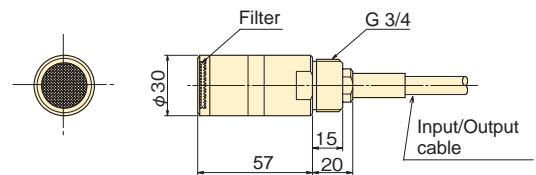

KPD-PA

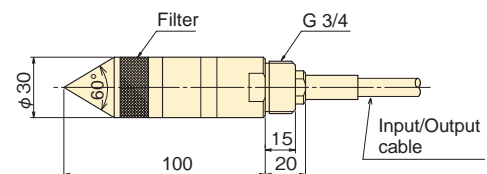

Input/Output cable :
φ 9mm 0.5mm² 4-core shielded chloroprene cable 2m

* : Filter mesh with 70μm available on request

Pore water pressure in model testing

KPE-PB Small Pore Pressure Gauge

Civil engineering design

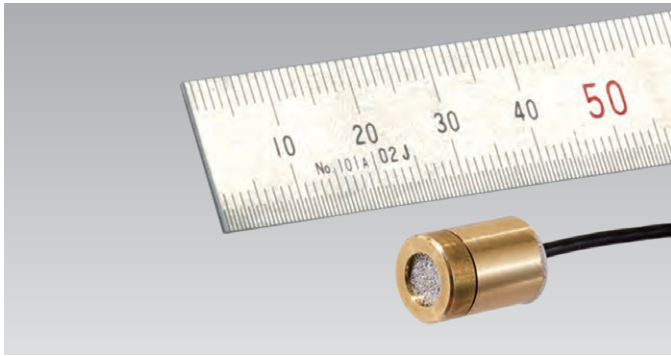

Small, lightweight
Easy handling
Dual structure not affected by the outer lateral pressure
Replaceable filter

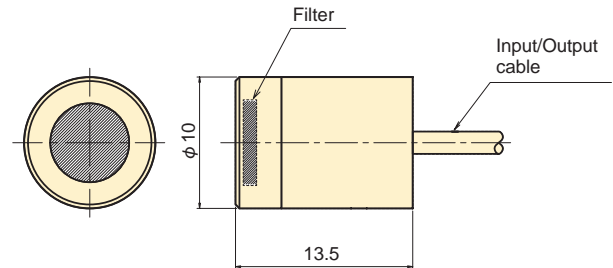

A small soil pressure gauge to measure pore water pressure in model testing. The dual construction not affected by lateral pressure offers accurate measurement.

Protection ratings: IP68 equivalent

SPECIFICATIONS

TYPE	KPE-200KPB	KPE-500KPB	KPE-1MPB	KPE-2MPB
Capacity	200kPa	500kPa	1MPa	2MPa
Rated output	Approx. 1mV/V (2000x10 ⁻⁶ strain)			
Non-linearity	1%RO			
Filter mesh	40μm(*)			
Allowable temperature range	0 ~ +60°C (No icing)			
Input/Output resistance	350Ω			
Recommended exciting voltage	2V or less			
Allowable exciting voltage	5V			
Weight	Approx. 4.5 g			

Input/Output cable : φ 1.7mm 0.035mm² 4-core shielded vinyl cable 2m

* : Filter mesh with 70μm available on request

KPG-PA Ultracompact Pore Pressure Gauge

NEW

Civil engineering design

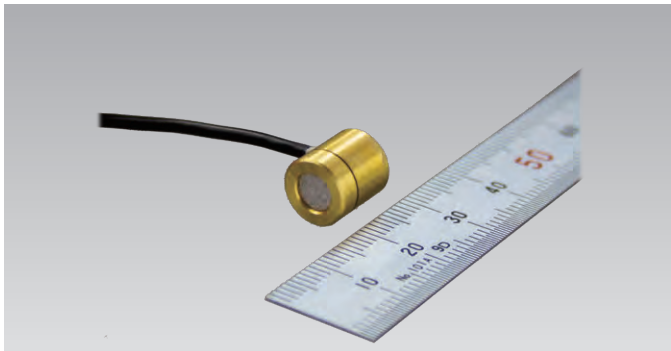

Small, lightweight
Easy handling
Dual structure not affected by the outer lateral pressure
Replaceable filter

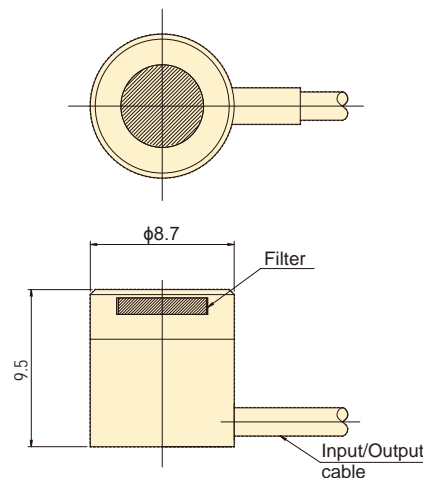

This is a miniature pore pressure gauge for measurement of pore water pressure in soil. It is designed for use in model testing, and is applicable to measurement for about one week under conditions within the specifications.

Protection ratings: IP68 equivalent

SPECIFICATIONS

TYPE	KPG-50KPA	KPG-100KPA	KPG-200KPA
Capacity	50kPa	100kPa	200kPa
Rated output	Approx. 0.5mV/V (1000x10 ⁻⁶ strain)	Approx. 0.75mV/V (1500x10 ⁻⁶ strain)	Approx. 1.6mV/V (3200x10 ⁻⁶ strain)
Non-linearity	1%RO		2%RO
Filter mesh	40μm		
Allowable temperature range	0 ~ +60°C (No icing)		
Input/Output resistance	350Ω		
Recommended exciting voltage	2V or less		
Allowable exciting voltage	5V		
Weight	Approx. 2.3 g		

Input/Output cable : φ 1.7mm 0.035mm² 4-core shielded vinyl cable 2m

Pore water pressure in model testing

KPH-PA Ultracompact Pore Pressure Gauge NEW

Civil engineering design

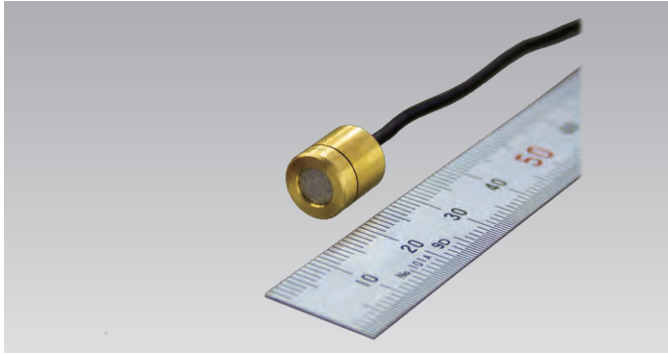

Small, lightweight
Easy handling
Dual structure not affected by the outer lateral pressure
Replaceable filter

This is a miniature pore pressure gauge for measurement of pore water pressure in soil. It is designed for use in model testing, and is applicable to measurement for about one week under conditions within the specifications.

Protection ratings: IP68 equivalent

■ SPECIFICATIONS

TYPE	KPH-50KPA	KPH-100KPA	KPH-200KPA
Capacity	50kPa	100kPa	200kPa
Rated output	Approx. 0.5mV/V (1000x10 ⁻⁶ strain)	Approx. 0.75mV/V (1500x10 ⁻⁶ strain)	Approx. 1.6mV/V (3200x10 ⁻⁶ strain)
Non-linearity	1%RO		2%RO
Filter mesh	40μm		
Allowable temperature range	0 ~ +60°C (No icing)		
Input/Output resistance	350Ω		
Recommended exciting voltage	2V or less		
Allowable exciting voltage	5V		
Weight	Approx. 2.3 g		

Input/Output cable : φ 1.7mm 0.035mm² 4-core shielded vinyl cable 2m

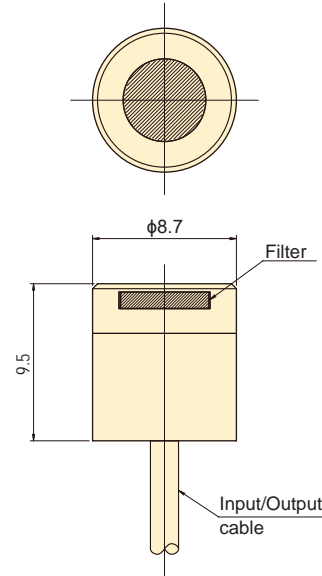

Level of water in dam, river and under-ground water

KW-C Water Level Transducer

Civil engineering design

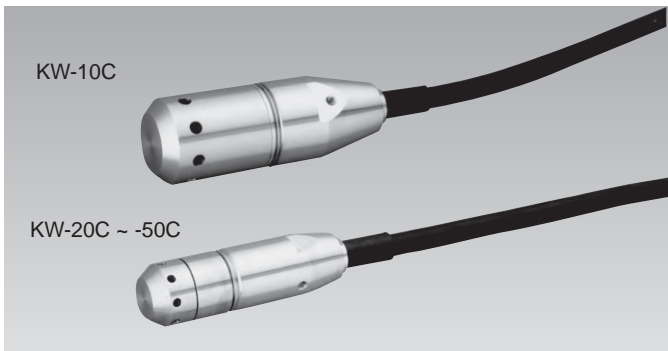

Not affected by the change of atmospheric pressure
Made of stainless steel with excellent corrosion resistance
Easy handling and stable measurement

The KW-C is a hydraulic water level transducer that measures the level of water in dams and rivers and the level of under-ground water in ground in landslide areas. Effects of changes in atmospheric pressure do not need to be compensated, so high-accuracy measurement can be made.

Protection ratings: IP68 equivalent

■ SPECIFICATIONS

TYPE	KW-10C	KW-20C	KW-30C	KW-50C
Capacity	10m	20m	30m	50m
Rated output	1mV/V (2000x10 ⁻⁶ strain)			
Non-linearity	0.2%RO		0.3%RO	
Temperature effect on zero	0.03%RO/°C			
Compensated temperature range	0 ~ +50°C (No icing)			
Allowable temperature range	-20 ~ +60°C (No icing)			
Input/Output resistance	350Ω			
Recommended exciting voltage	3V or less			
Allowable exciting voltage	10V			
Weight	700 g	200g		

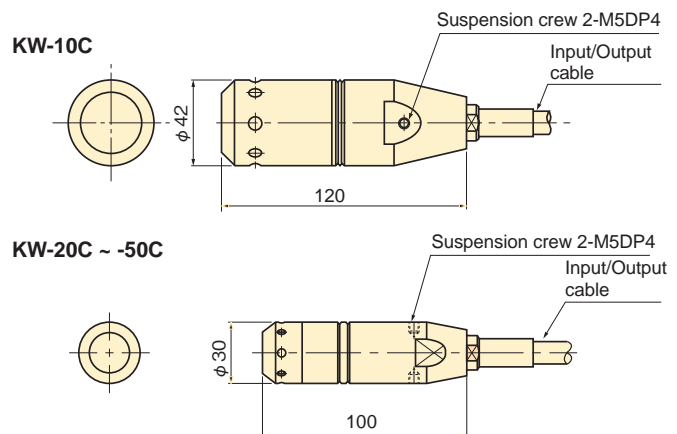

Input/Output cable :

- KW-10C φ 11.5mm 0.5mm² 4-core shielded vinyl cable with air-vent tube 13m
- KW-20C φ 11.5mm 0.5mm² 4-core shielded vinyl cable with air-vent tube 23m
- KW-30C φ 11.5mm 0.5mm² 4-core shielded vinyl cable with air-vent tube 33m
- KW-50C φ 11.5mm 0.5mm² 4-core shielded vinyl cable with air-vent tube 53m



The KB-AB and KB-AC are low-capacity inclinometers. They are used to monitor the conditions of inclination of neighboring structures built by urban civil engineering works. The KB-AB measures inclination in one direction, while the KB-AC measures inclination in both X and Y directions.

Protection ratings: IP67 equivalent

Made of all stainless steel with excellent corrosion resistance

Easy carriage and installation with external stopper
Two (X and Y) directional measurement with KB-AC
Excellent stability

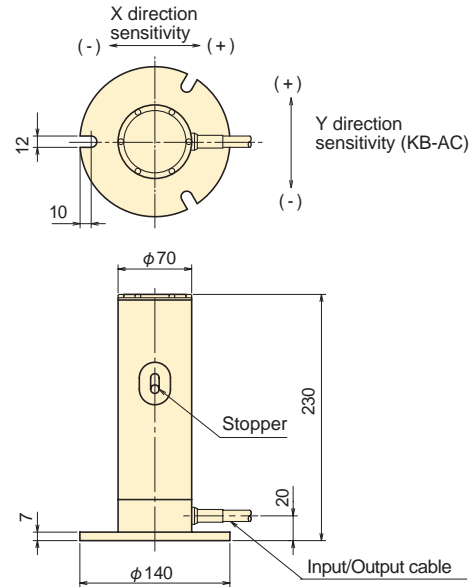

CONNECTION TO DATA LOGGER

X and Y directions Inclinometer KB-AC with 8-core integral cable

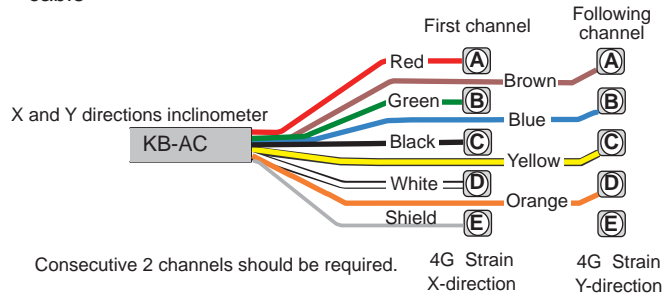

SPECIFICATIONS

TYPE	KB-1AB	KB-2AB	KB-5AB	KB-1AC	KB-2AC	KB-5AC
No. of measuring direction	1			2		
Capacity	±1°	±2°	±5°	±1°	±2°	±5°
Rated output	1mV/V (2000x10 ⁻⁶ strain)					
Non-linearity	0.5%RO					
Cross sensitivity	-			3%RO or less		
Allowable temperature range	-20 ~ +60°C					
Input/Output resistance	350Ω					
Recommended exciting voltage	2V or less					
Allowable exciting voltage	5V					
Weight	5 kg					

Input/Output cable :
 KB-AB φ9mm 0.5mm² 4-core shielded chloroprene cable 2m
 KB-AC φ9mm 0.3mm² 8-core shielded vinyl cable 2m

ACCESSORY

Protective cover KBF-13

This cover protects the KB-AB//KB-AC inclinometer installed to structure from mechanical damage.



Wall mount fitting KBF-14

This fitting is used to mount the KB-AB/KB-AC inclinometer to wall of structure.



Flat mounting fitting KBF-15

This fitting is used to mount the KB-AB/KB-AC inclinometer to flat surface.



Level KBF-16

This level is standardly supplied to the KB-AB/KB-AC inclinometer.



Inclination/Slope of structures being constructed

KB-DB/KB-EB Inclinator

Civil engineering design



The KB-DB and KB-EB inclinometers are suitable for monitoring the conditions of structures being constructed or measuring the behavior of structures for a long period. The KB-DB is for measurement in one direction, while the KB-EB is for simultaneous measurement in both X and Y directions.

Protection ratings: IP67 equivalent

Made of all stainless steel with excellent corrosion resistance

Wall mounting and vertical installation

Waterproofness and excellent stability

Two (X and Y) directional measurement with KB-EB

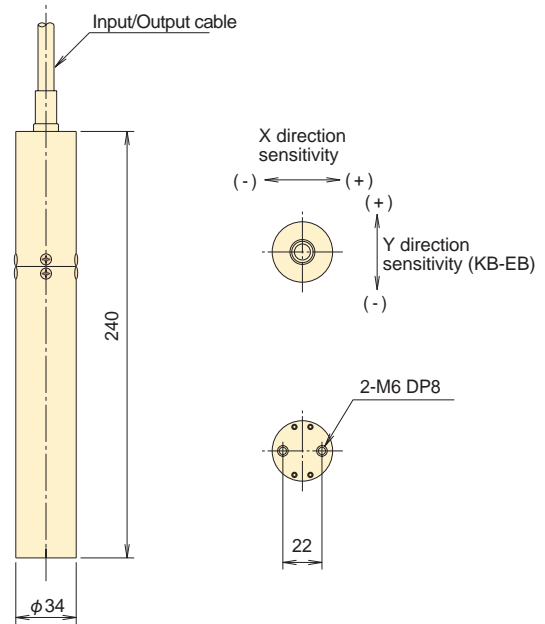

CONNECTION TO DATA LOGGER

X and Y directions Inclinator KB-EB with 8-core integral cable

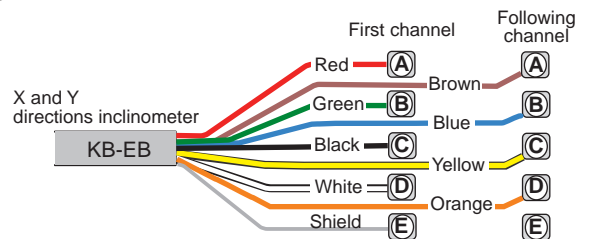

Consecutive 2 channels should be required.

4G Strain X-direction

4G Strain Y-direction

SPECIFICATIONS

TYPE	KB-5DB	KB-10DB	KB-5EB	KB-10EB
No. of measuring direction		1		2
Capacity	±5°	±10°	±5°	±10°
Rated output	1mV/V (2000x10 ⁻⁶ strain)			
Non-linearity	0.5%RO			
Cross sensitivity			3%RO or less	
Allowable temperature range	-20 ~ +60°C			
Input/Output resistance	350Ω			
Recommended exciting voltage	2V or less			
Allowable exciting voltage	5V			
Weight	1.3 kg			

Input/Output cable :

KB-5DB/-10DB

φ9mm 0.5mm² 4-core shielded chloroprene cable 2m

KB-5EB/-10EB

φ9mm 0.3mm² 8-core shielded vinyl cable 2m

ACCESSORY

Wall mount fitting KBF-17

This fitting is used to mount the KB-DB/KB-EB inclinometer to wall of structure.

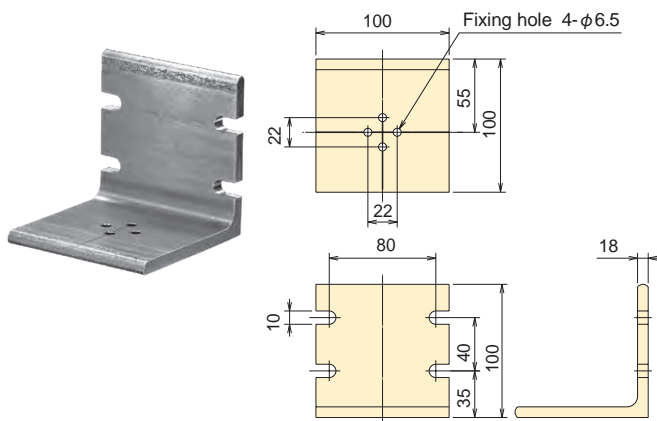

Flat mount fitting KBF-18

This fitting is used to mount the KB-DB/KB-EB inclinometer to flat surface.

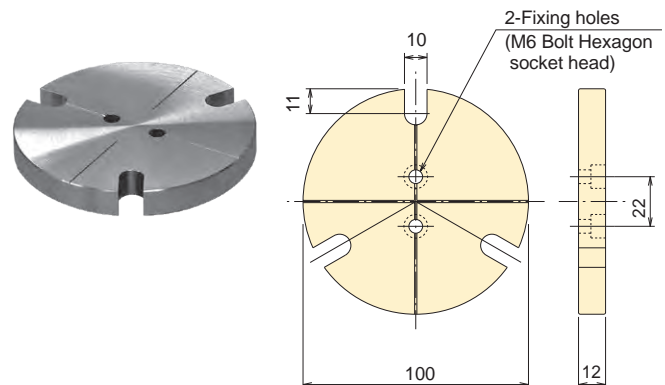

Stress of reinforcing bars arranged

KSAT-A Reinforcing Bar Meter

Civil engineering design

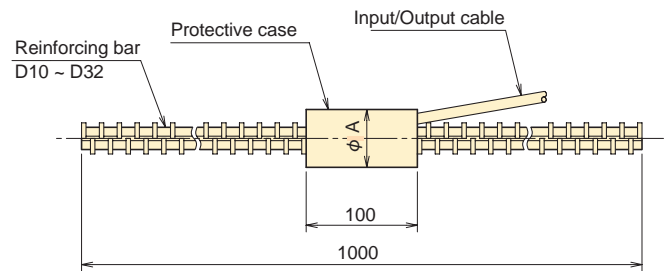

The KSAT-A are used to measure stress applied to structural reinforcing bars, and are normally welded at both ends to form part of the reinforcement arrangement. And the meters are with built-in temperature sensor, making possible simultaneous measurement of stress and temperature. The KSAT-A has a thermocouple that can be used to measure actual temperature.

Protection ratings: IP68 equivalent

Temperature measuring function to measure real temperature

Long-term stable measurement

Capable of measuring thermal stress

■ SPECIFICATIONS

TYPE	φ A	Applical bar		Yield point
		Name	Class	
KSAT-10A	33	D10	SD345	345~440N/mm ²
KSAT-13A	36	D13		
KSAT-16A	42	D16		
KSAT-19A	47	D19		
KSAT-22A	47	D22		
KSAT-25A	53	D25		
KSAT-29A	53	D29		
KSAT-32A	62	D32		

Other bar with different size is available. Consult TML.

■ CONNECTION TO DATA LOGGER

KSAT-A with built-in thermocouple

Consecutive 2 channels should be required.

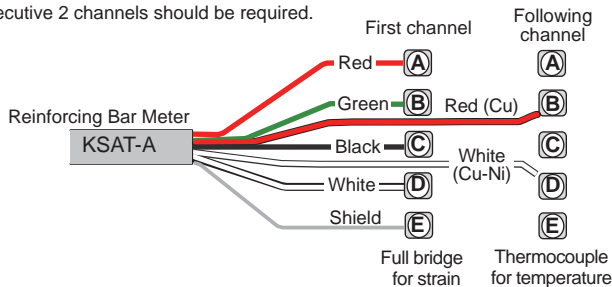

Stranded cables of Red, Green, Black and White to the first channel for strain measurement. Thermocouple of single core Red (Cu) and White (Cu-Ni) should be connected directly to the following channel for temperature measurement.

■ SPECIFICATIONS

TYPE	KSAT-10A	KSAT-13A	KSAT-16A	KSAT-19A	KSAT-22A	KSAT-25A	KSAT-29A	KSAT-32A
Capacity	300 N/mm ²							
Rated output	2.2mV/V (4400x10 ⁻⁶ strain)							
Non-linearity	1%RO							
Temperature sensor	KSA-A : Strain gauge 350Ω Quarter bridge with 3-wire (Approx. 50x10 ⁻⁶ strain/°C) in relative temperature KSAT-A : Thermocouple T in real temperature							
Allowable temperature range	-20 ~ +80°C							
Input/Output resistance	350Ω							
Recommended exciting voltage	6V or less							
Allowable exciting voltage	10V							
Weight	0.9 kg	1.3 kg	1.9 kg	2.6 kg	3.4 kg	4.3 kg	5.4 kg	6.6 kg

Input/Output cable :

KSAT-10A ~ 16A φ9mm 0.3mm² 4-core shielded T-thermocouple compound cable 2m

KSAT-19A ~ 32A φ11.5mm 0.5mm² 4-core shielded T-thermocouple compound cable 2m

Internal strain of concrete, synthetic resin

KM Strain Transducers

Civil engineering design



The KM series strain transducers are designed to measure strain in materials such as concrete, synthetic resin which undergo a transition from a compliant state to a hardened state. Their extremely low modulus (40N/mm² approx.) and waterproof construction are ideally suited for internal strain measurement during the very early stages of curing. They are totally impervious to moisture absorption, producing excellent stability for long-term strain measurement. Relative temperature measurement is also possible with the KM-B. The built-in thermocouple sensor of the KM-BT enable actual temperature measurement in addition to strain measurement. Adding to the above embedment use, surface strain measurement onto concrete, H-beam steel is also available with various optional fittings.

The KM series is compliant to CE marking except for KM-30 and KM-50F.

Protection ratings: IP67 equivalent for KM-30
IP68 equivalent for KM-50F ~ KM-100BT

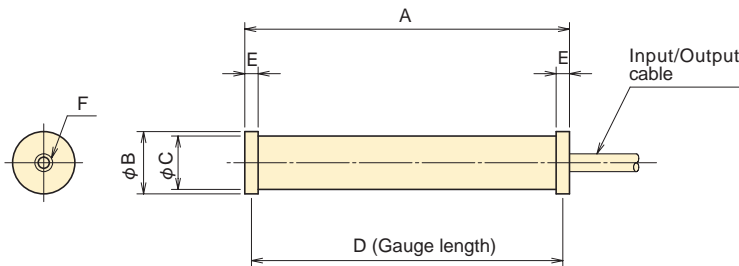

■ DIMENSION

TYPE	Dimension					
	A	φ B	φ C	D	E	F
KM-30	34	12	10	31	3	M3 DP4
KM-50F	54	20	17	50	4	M3 DP6
KM-100B	104	20	17	100	4	M3 DP6
KM-100HB	104	20	17	100	4	M3 DP6
KM-100BT	104	20	17	100	4	M3 DP6

■ CONNECTION TO DATA LOGGER

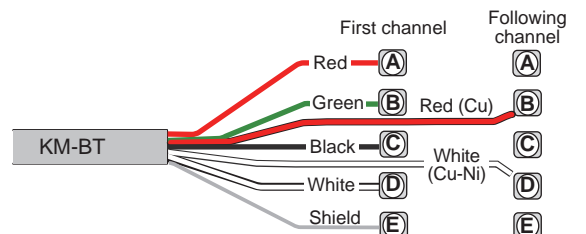
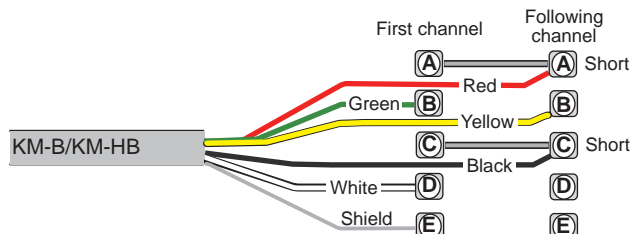
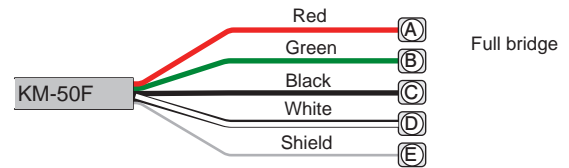
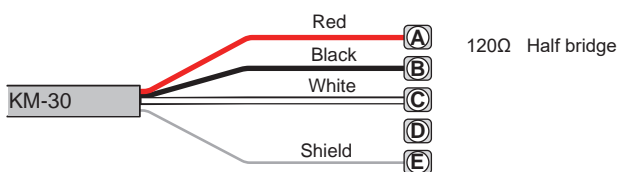

Consecutive 2 channels should be required for simultaneous measurement of strain and temperature.

Stranded cables of Green, White and shield are connected to the first channel. Remaining cables of Red, Yellow and Black should be connected directly to the following channel for temperature measurement, making short-circuit between A-A and C-C with copper wire for strain measurement.

Consecutive 2 channels should be required for simultaneous measurement of strain and temperature.

Stranded cables of Red, Green, Black, White and shield to the first channel for strain measurement. Thermocouple of single core Red and White should be connected directly to the following channel for temperature measurement.

■ SPECIFICATIONS

TYPE	KM-30	KM-50F	KM-100B	KM-100HB	KM-100BT
Capacity	±5000x10 ⁻⁶ strain				
Gauge length	31mm	50mm	100mm		
Rated output (Approximately)	2.5mV/V 5000x10 ⁻⁶ strain	4mV/V 8000x10 ⁻⁶ strain	2.5mV/V 5000x10 ⁻⁶ strain		
Non-linearity	1%RO				
Apparent elastic modulus	40N/mm ²				
Strain measurement	120Ω Half bridge	350Ω Full bridge			
Temperature measurement			*1 Strain gauge (350Ω Quarter bridge 3-wire method :50x 10 ⁻⁶ strain/°C)		*2 Thermocouple T
Allowable temperature range	-20 ~ +60°C	-20 ~ +80°C		-20 ~ +180°C	-20 ~ +80°C
Input/Output resistance	120Ω (Half bridge)	350Ω Full bridge			
Weight	12 g	45 g	75 g	80 g	75 g

Input/Output cable :
 KM-30 φ 2.4mm 0.04mm² 3-core shielded vinyl cable 2m
 KM-50F φ 6mm 0.35mm² 4-core shielded chloroprene cable 2m
 KM-100B φ 9mm 0.3mm² 5-core shielded fluoroplastic cable 2m
 KM-100BT φ 9mm 0.3mm² 4-core shielded T-thermocouple compound cable 2m

*1 Relative temperature measurement possible
 *2 Real temperature measurement possible

Internal strain of asphalt pavement

KM Strain Transducers

Civil engineering design

For use of internal strain measurement

The KM Strain Transducers make possible strain measurement in materials such as concrete which undergo transition from a compliant state to a hardened state. The KM is designed to measure various strains produced by external force, ambient temperature, drying shrinkage, materials creep, etc. Applicable gauge length should be three times as large as the diameter of the aggregate so as to give an averaged evaluation of the concrete.

As illustrated right, the KM end is wired between reinforcing bars, then position the KM to marked points of reinforcing bar in advance.

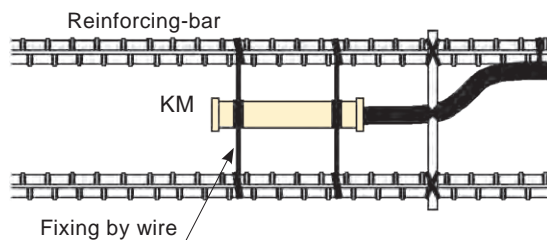

For surface strain measurement

Surface strain measurement onto steel and concrete structures is available with KM-100B or KM-100BT. (Optional fittings such as Spacer and Collar are available for fixing the model and positioning gauge length.)

An installation onto the surface of steel structure



The KM model is combined with optional Collar KMF-22-100 to install onto the surface of steel by welding.

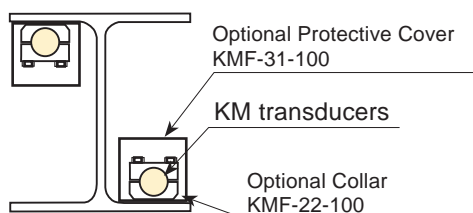

An installation onto the surface of concrete structure

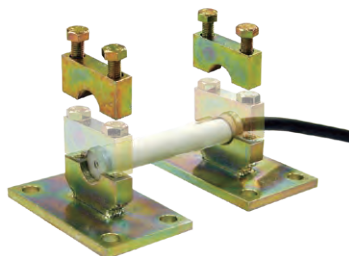

The KM model is combined with optional Collar KMF-23B-100 to install onto the surface of concrete structure with anchor bolts.

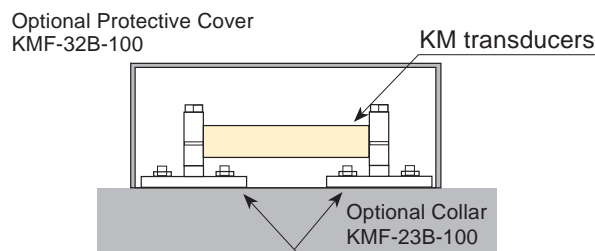

KM-HAS Strain Transducers

Civil engineering design

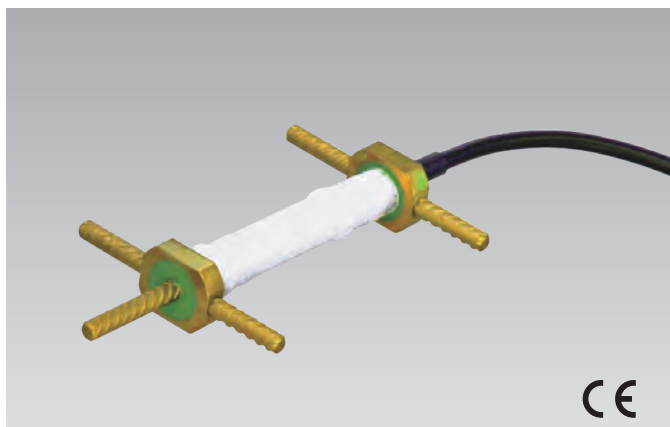

The KM-HAS transducers are embedded into asphalt for measurement of internal strain. The transducers have reinforcing bar flanges at its both ends for good fixation to asphalt pavement materials, and provide for fully waterproof construction. The operating temperature range is -20 to +180°C.

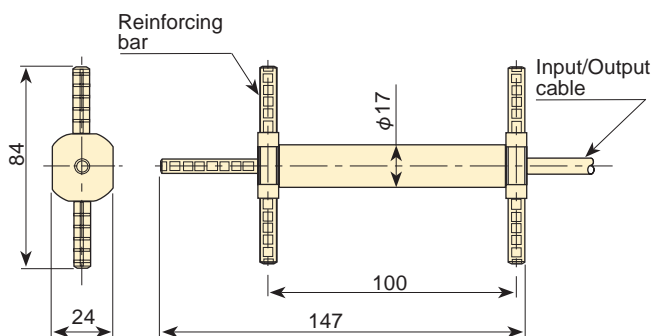

■ SPECIFICATIONS

TYPE	KM-100HAS
Capacity	$\pm 5000 \times 10^{-6}$ strain
Gauge length	100mm
Rated output (Approximately)	2.5mV/V (5000×10^{-6} strain)
Non-linearity	1%RO
Apparent elastic modulus	Approx. 40N/mm ²
Strain measurement	350Ω Full bridge
Temperature measurement	350Ω Quarter bridge 3-wire
Allowable temperature range	-20 ~ +180°C
Bridge excitation	Recommended 1~2V, Allowable 10V

Friction force on concrete caisson

KKA-PB Caisson skin-friction meter

Civil engineering design

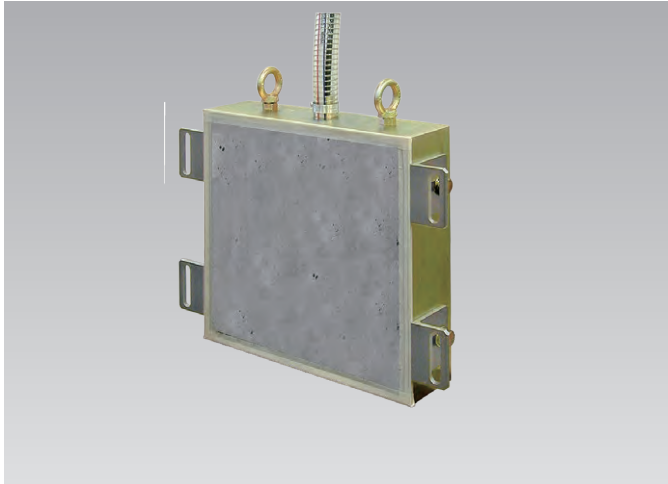

The KKA-PA is a transducer to measure the skin-friction bearing force of a caisson, which is acting on the wall of a concrete caisson generated by the friction between the ground and the concrete surface. The transducer is installed so that the sensing surface of the transducer is positioned in the same surface with the caisson wall. The skin-friction bearing force by the ground is measured during the immersion and settlement of the caisson.

Protection ratings : IP 67 equivalent

For skin-friction meter for steel caisson, please contact us.

SPECIFICATIONS

TYPE	KKA-200KPB	KKA-300KPB
Capacity	200kPa	300kPa
Rated output	1.5mV/V (3000x10 ⁻⁶ strain)	
Non-linearity	1%RO	
Allowable temperature range	-30 ~ +70°C (No freezing)	
Input/Output resistance	350Ω	
Recommended exciting voltage	2V	
Allowable exciting voltage	10V	
Zero balance	±1500x10 ⁻⁶ strain or less	
Weight	33 kg	

Input/Output cable : φ9mm 0.5mm² 4-core shielded chloroprene cable 2m

Observation and control of caisson driving process

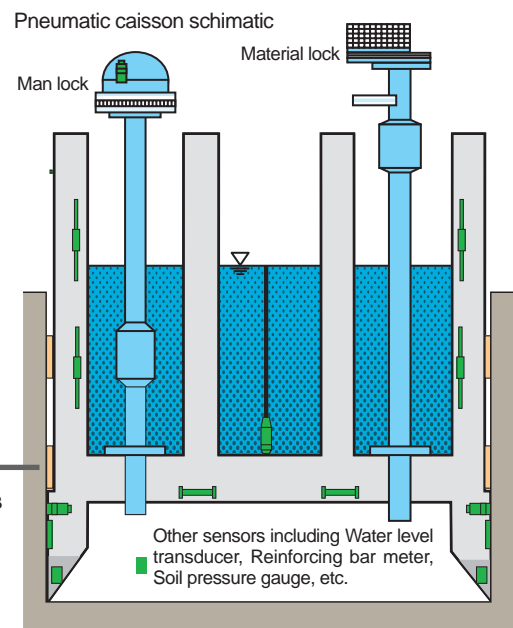
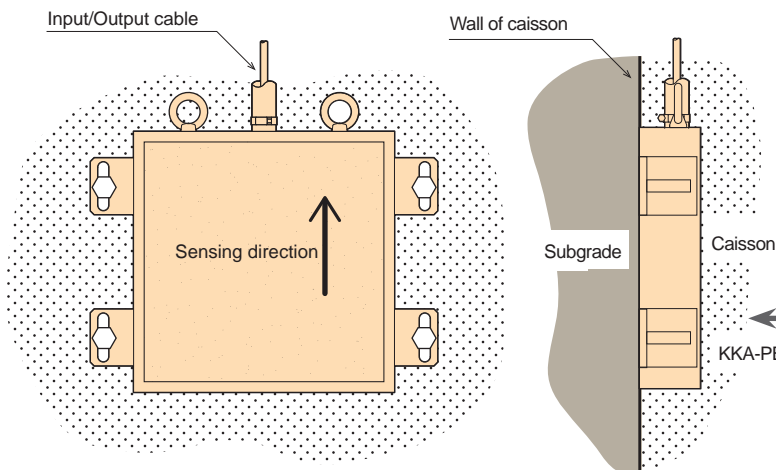
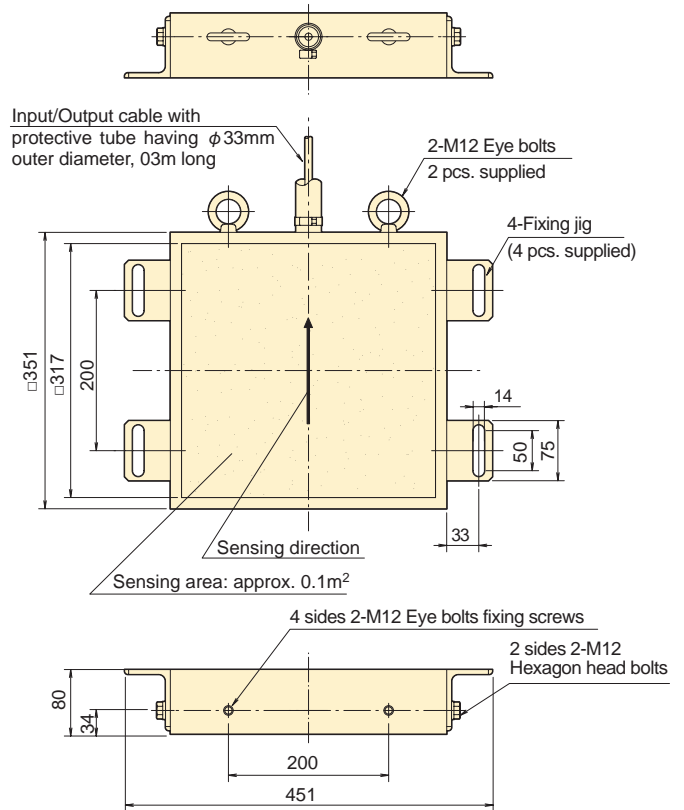

Subgrade reaction force of caisson

KKB-PB Caisson cutting-edge reaction meter

Civil engineering design

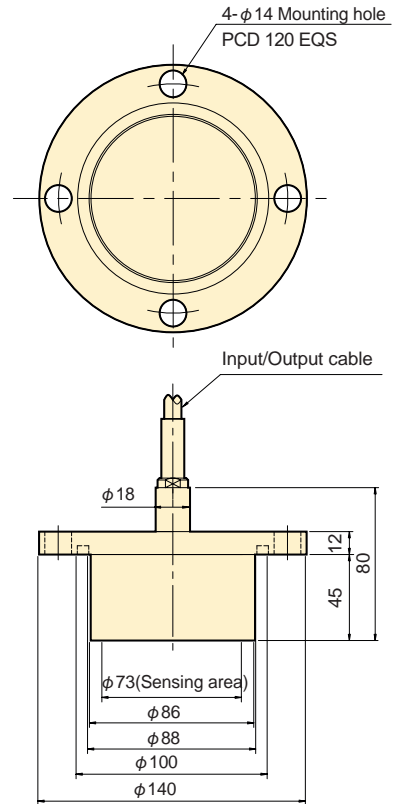
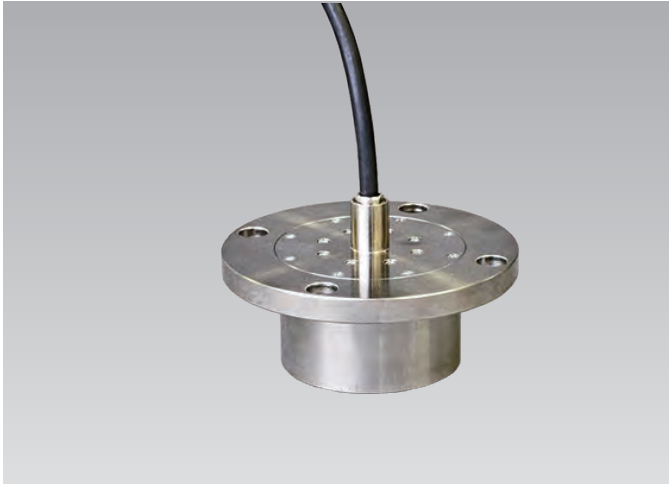

The KKB-PA is a transducer to measure the subgrade reaction force (bearing force) acting on the caisson cutting edge. The transducer is installed so that the sensing surface of the transducer is positioned in the same surface with the bottom surface of the caisson cutting edge. The subgrade reaction force is measured during the immersion and settlement of the caisson.

Protection ratings: IP 68 equivalent

When ordering, please clarify the shape of the cutting edge.

Measurement of subgrade reaction force on caisson cutting edge

■ SPECIFICATIONS

TYPE	KKB-5MPB	KKB-10MPB	KKB-15MPB
Capacity	5MPa	10MPa	15MPa
Rated output	1.0mV/V (2000x10 ⁻⁶ strain)		
Non-linearity	1%RO		
Allowable temperature range	-30 ~ +70°C (No freezing)		
Allowable overload	150%		
Input/Output resistance	350Ω		
Recommended exciting voltage	3V or less		
Allowable exciting voltage	10V		
Weight	3.2 kg		

Input/Output cable : φ9mm 0.5mm² 4-core shielded chloroprene cable 2m

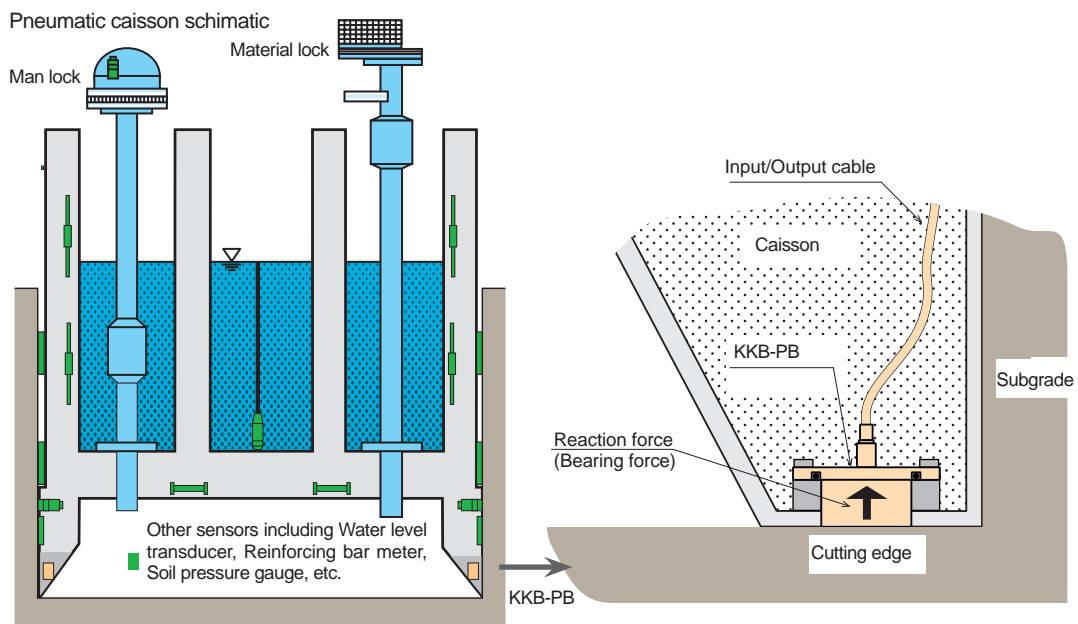

Subgrade reaction and elasticity modulus

FWD-Light TML Small Falling Weight Deflectometer

Civil engineering design

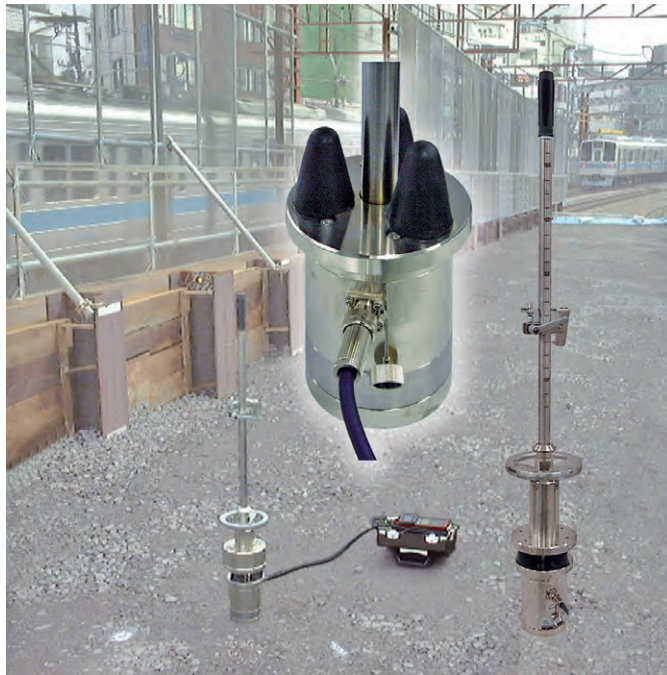

Simple and quick measurement of coefficient of subgrade reaction and modulus of subgrade elasticity

2-wire digital network lines

Battery driven

Main unit KFD-100A

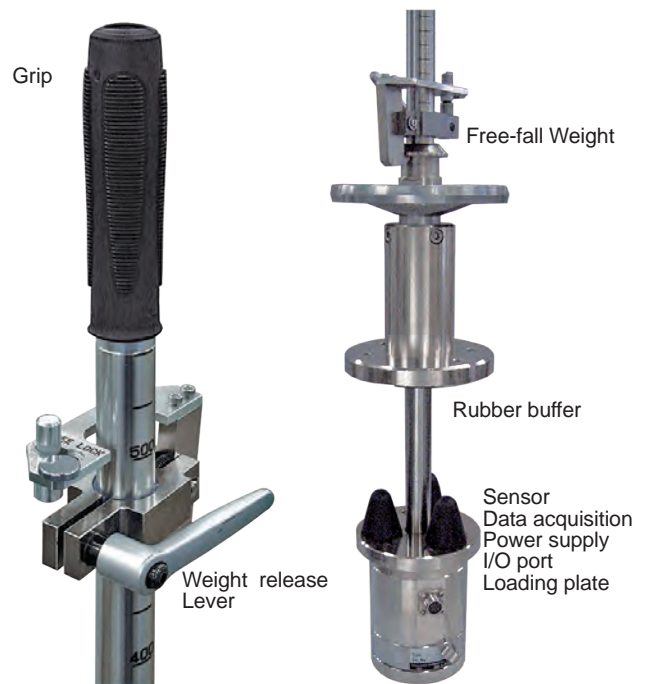

FWD (Falling Weight Deflectometer) is used for estimating construction of pavement or rigidity of subgrade. Also, plate loading test is used for estimating characteristics of subgrade. However, these methods require much time and works for their preparation, data acquisition and analysis. TML small FWD System "FWD-Light" features excellent portability and enables simple and quick measurement of coefficient of subgrade reaction which is called K value and modulus of subgrade elasticity which is called E value. FWD-Light consists of main body KFD-100A and indicator TC-351F. The main body includes load cell and acceleration transducer whose measuring ranges are 20kN of load and 2.5mm of displacement at maximum. Values of maximum load and displacement, and analysis results of K value and E value are indicated on the indicator. Each analysis result can be stored in memory card and printed by exclusive printer. Data stored in memory card can be transferred to a personal computer by directly connecting the card or via the indicator. Measurement and processing software TC-7100 is available as an optional item for indicating waveforms of load, acceleration, velocity and displacement, O-P time and time product using personal computer.

Protection ratings : IP 42 equivalent

Waveform indication using optional Measurement/Analysis software TC-7100

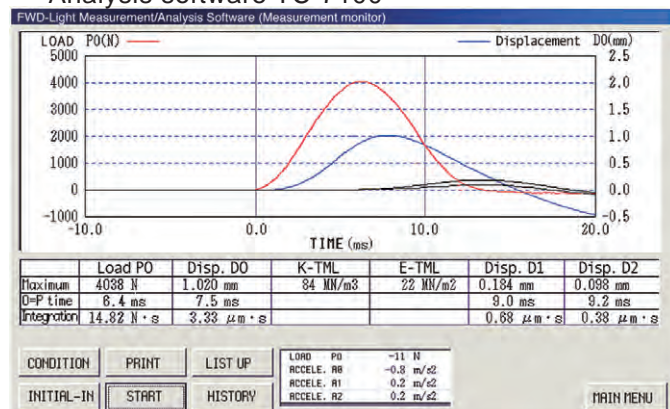

Load and displacement measurements of four channels at maximum are possible.

SPECIFICATIONS

Type	KFD-100A	
Dimensions of loading plate	φ 100 x 15 (thick) mm (KFDF-31-100)	
Mass of weight	5 kg	
Falling height	50~530mm	
Falling method of weight	Lever with stopper	
Sensor	Load Cell	Rated capacity : 20kN Maximum load : 20kN
	Acceleration transducer	Rated capacity : 500m/s ² Maximum displacement : 2.500 mm
Data acquisition		
No. of measuring points	2 points (load and acceleration)	
Measuring accuracy	±(0.1% rdg.+2 digits) at 23±5°C	
Sampling speed	800 data/point, 50 μsec.	
Trigger function	By data (Load Cell) Pre-trigger saving	
Interface	Exclusive 2-wire serial transfer	
No. of external displacement transducer	4 points at maximum	
Power source	Supplied by TC-351F	
Environment	-20~+60°C 85%RH or less (No condensation)	
Protection ratings	IP 42 equivalent	
Height	Approx. 1,100 mm	
Weight	15 kg including 5 kg weight	

Exclusive indicator TC-351F



Designed for field measurement
Measured data saved in CF card
Acquires a lot of data in a short period of time
Battery driven

■ SPECIFICATIONS

Type	TC-351F
Display	Liquid crystal display 128x64 dots
Monitor	Load, Acceleration, Acceleration of external displacement sensor, Time
Analysis results	Maximum load, Maximum displacement, Maximum displacement of external sensor, Coefficient of subgrade reaction (K_{TML}), Modulus of subgrade elasticity (E_{TML}), Indicates results of last four measurements
Data memory	7500 measurements at maximum
Memory card	CF card with adaptor, Capacity 8~128MBytes
Recording format	CSV
Interface	RS-232C
Power supply	Nickel-Hydride (Ni-MH) battery pack
Continuous operation	Approx. 32 hours or 1000 times measurements at $23^{\circ}\text{C}\pm 5^{\circ}\text{C}$ when measured 30 times/1 hour by standard configuration with fully charged battery
Vibration tolerance	30m/s^2 at 50Hz 0.6mm _{p-p}
Environment	$-10\sim+50^{\circ}\text{C}$ 85%RH or less (No condensation)
Dimensions	Approx. 150(W) x 120(H) x 265(D) mm
Weight	3 kg

The indicator indicates results of analyses and also saves them into CF card. Measurement/Analysis software (TC-7100) is required for measurement system with personal computer. In this system, data indicated on the indicator are transferred to the computer through the indicator without modification. Personal computer displays waveforms of load and displacement and also processes each analysis.

Protection ratings : IP 54 equivalent

Display exampled

No.	P0 [N]	D0 [mm]	K-TML [MN/m ²]
04	3290	0.501	279
03	3122	0.457	290
02	2751	0.402	290
01	2345	0.386	258

No.	E-TML [MN/m ²]	D1 [mm]	D2 [mm]
04	49	0.022	0.013
03	51	0.021	0.012
02	51	0.018	0.012
01	46	0.012	0.011

Monitoring external displacement sensor optional

OPTION

External Displacement Sensor KFDS-1B

Measurement of external displacement of four points at maximum is available by combining External Displacement Sensor KFDS-1B.

- Maximum displacement: 1.000mm
- Dimensions $\phi 79 \times 125$ (H) mm
- Weight 1.5 kg



Measurement/Analysis software TC-7100

Measurement and processing software for controlling TML Small FWD and analyzing measured data using personal computer which runs on Windows OS. It is available as an optional item for indicating waveforms of load, acceleration, velocity and displacement, O-P time and time product using the PC.

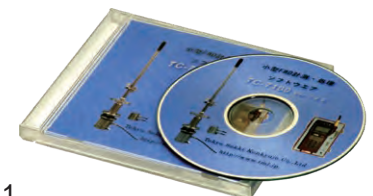

Loading plate KFDF-31

Different size of loading plates are available depending on pavement or rigidity of subgrade.

- KFDF-31-90 90mm-dia.
- KFDF-31-150 150mm-dia.
- KFDF-31-200 200mm-dia.
- KFDF-31-300 300mm-dia.



Additional weight KFDF-11









Different loading weights are available to adjust the specified displacement depending on size of loading plate.

- KFDF-11-10 10 kg with KFDF-11-05
- KFDF-11-15 15 kg with KFDF-11-10

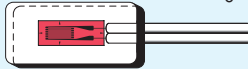

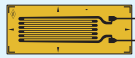



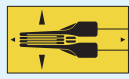
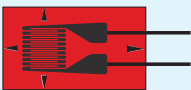



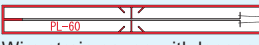





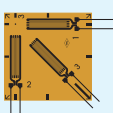

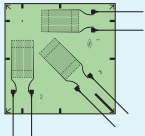
Strain Gauges - Standard/Weldable/Special



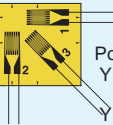
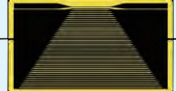

Standard type

<p>F series General purpose</p> <p>-196 ~ +150°C GOBLET </p>  <p>GOBLET Featuring unique gauge pattern Improved fatigue life under the use of lead-free solder. RoHS compliant with CE</p>	<p>F series</p> <p>-196 ~ +150°C</p>  <p>Shearing/Torque/ Stress concentration</p>	<p>WF series with waterproof coating</p> <p>0 ~ +80°C</p>  <p>Waterproof type with a pre-attached vinyl lead wire and an entire coating with epoxy resin</p>	<p>QF series for use upto +200°C</p> <p>GOBLET </p>  <p>High temperature use strain gauge available upto 200°C. lead-free solder. RoHS compliant with CE</p>
<p>ZF series for use upto +300°C</p>  <p>High temperature use strain gauge available upto 300°C</p>	<p>EF series with miniature gauge</p> <p>Single element:  -196 ~ +300°C 2-/3-element: -196 ~ +200°C</p>  <p>Designed miniature grid pattern to measure the mechanical properties of printed circuit boards</p>	<p>CEF series for use in -269 to +200°C</p>  <p>High and low temperature strain gauge and wide range of applicable temperature -269 ~ +200 °C</p>	<p>CF series for use down to -269°C</p>  <p>Cryogenic temperature use strain gauge</p>

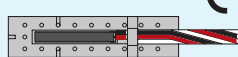

Special use

<p>P/PF series for concrete, wood</p> <p>-20 ~ +80°C </p>  <p>Wire strain gauge with longer gauge length up to 120mm</p>  <p>Foil strain gauge for concrete and wood specimen</p>	<p>PFLW/PLW series for wood</p> <p>-20 ~ +80°C</p>  <p>Usable for long term measurement on woods, not affected by moisture</p>	<p>PMFLS series for asphalt pavement</p> <p>-20 ~ +60°C</p>  <p>Usable into asphalts for loading test such as rolling compaction. Withstands temperature upto +200°C when placing asphalts.</p>	<p>PMF series for concrete</p> <p>-20 ~ +60°C</p>  <p>Employs super engineering plastics capable of waterproofing, measuring interior strain in concrete or mortar under loading test</p>
<p>LF series for wood and gypsum</p> <p>-30 ~ +80°C GOBLET </p>  <p>Measurement on materials having low elastic modulus such as wood or gypsum. Specially designed grid reduces the stiffening effect.</p>	<p>UBF/BF series for composite</p>  <p>Designed for composite materials UBF with single element -20~+150°C BF with single, 2-, 3- element GOBLET -30~+200°C</p>	<p>GF series for plastic</p> <p>-30 ~ +80°C GOBLET </p>  <p>Low elastic strain gauges with single, 2-, 3-element</p>	<p>MF series for use in magnetic field</p>  <p>Single element -30~+200°C with twisted vinyl leadwire</p>  <p>2-/3-element -20~+200°C with twisted Fluoride resin leadwire</p>
<p>BTM series for bolt embedment use</p> <p>-10 ~ +80°C </p>  <p>gauge lead hole drilled bolt specimen adhesive filled BTM embedded</p>	<p>YEF/YF/YHF series for large strain</p> <p>-20 ~ +80°C</p>  <p>Post-yield strain gauge YEF series for 15% large strain GOBLET YF series for 20% large strain YHF series for 40% large strain</p>	<p>FAC gauge for crack propagation</p>  <p>-30 ~ +80°C </p> <p>Measures progress(length) of a crack and its ratio of growth in metal speci- men</p>	<p>DSF series for fatigue test</p> <p>-60 ~ +200°C </p>  <p>High endurance strain gauge with fatigue life of 10 million times or more at $\pm 3000 \times 10^{-6}$ strain level in normal temperature</p>

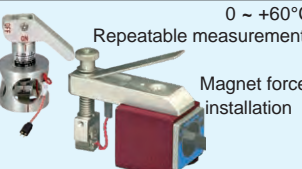
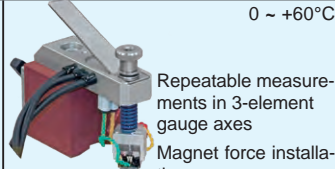
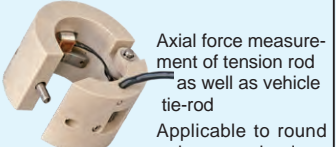

Weldable type

<p>AW series AW-6-350-11-01LT</p> <p>-196 ~ +300°C </p>  <p>Quarter bridge 3-Wire system</p>	<p>AW series AWC-8B</p>  <p>Quarter bridge 3-Wire system AWC-8B-11-3LT -20 ~ +100°C</p>	<p>AW series -196~ +800°C</p>  <p></p> <p>AWM-8 -196 ~ +300°C AWMD-5/-8 -196 ~ +800°C (Dynamic use) AWHU-5/-8 -196 ~ +800°C AWH-4/-8 -196 ~ +650°C</p>	<p>W-50RC Spot Welder</p>  <p>Installation of Weldable strain gauge AW series and leadwires W-50RC complies with CE marking.</p>
---	---	--	--

Frictional strain gauge type

<p>Strain Checker FGMH-1B/ -2A</p> <p>0 ~ +60°C</p>  <p>Repeatable measurement Magnet force installation</p>	<p>Strain Checker FGMH-3A</p> <p>0 ~ +60°C</p>  <p>Repeatable measure- ments in 3-element gauge axes Magnet force installa- tion</p>	<p>Axial Strain Transducer FGAH-1B</p> <p>-20 ~ +60°C</p>  <p>Axial force measure- ment of tension rod as well as vehicle tie-rod Applicable to round or hexagonal rod</p>	<p>Torque Transducer FGDH-3A</p> <p>-20 ~ +60°C</p>  <p>Digital telemetry Compatible with driving shafts with different diameters 20~50mm</p>
--	--	---	---

Strain Gauge Adhesives and Coating Materials

<p>Adhesives</p> 	<p>Coating Materials</p> 
---	--

TML strain gauge series are roughly classified into 4 types depending on the method of installation.

1. Adhesive bonding type

In general, most of strain gauges are installed on the surface of test specimen with adhesive. Measurement is possible as far as the specimen material is bondable with adhesive. This method can be applied to various materials including metal, concrete, wood and composite material. After installation, coatings should be applied to protect the strain gauges and leadwires from various environmental conditions. The availability of this bonding type depends on the operating temperature of adhesive. The maximum operating temperature is 300°C.

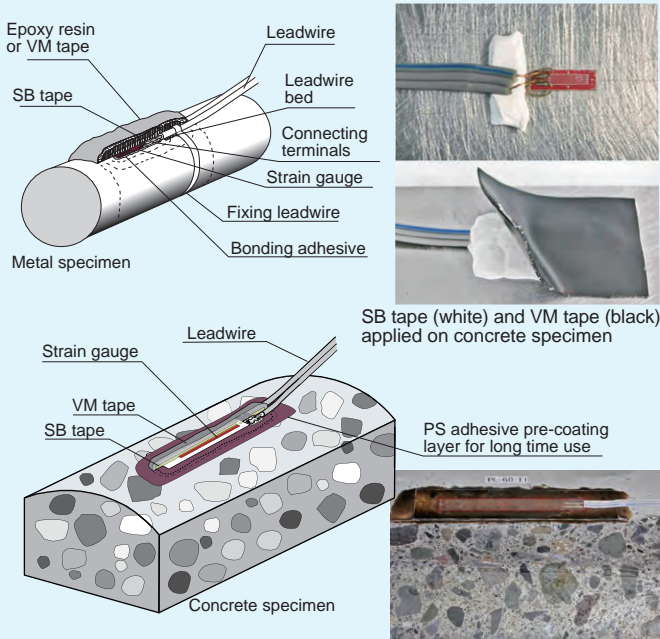

2. Electrical Spot weldable type

The strain gauge of this type is fully encapsulated in a corrosion-resisting metal tube for use in various conditions, such as gas-filled and underwater environments. It is constructed heat resistant, and the installation is made by electrical spot welding which maintains excellent fixation even in high temperature. The operating temperature range is from -196°C to +800°C. Naturally, the specimen material must be a metal which allows electrical spot welding.

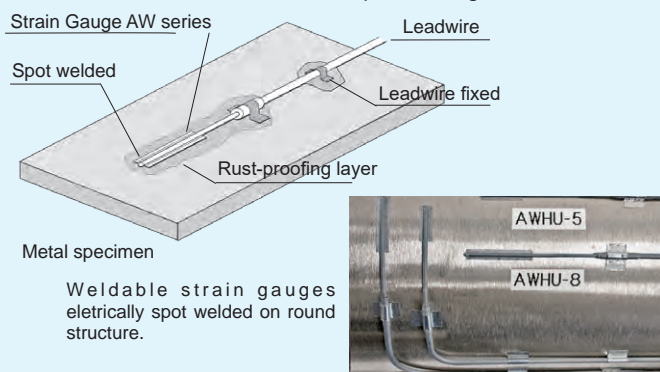

3. Frictional gauge type (Re-usable type)

This gauge consists of a soft rubber layer on its contact surface and a magnet which presses the strain gauge against the specimen surface by magnetic force. It measures strain by friction which is caused between the contact surface of strain gauge and the measurement surface of the metal specimen. It has the advantage of being usable repeatedly because it is attached by magnetic force without using adhesive. Since the measurement point can be moved easily, it is useful for preparatory or supplemental measurement. The maximum operating temperature is 60°C because of adopting magnetic force.

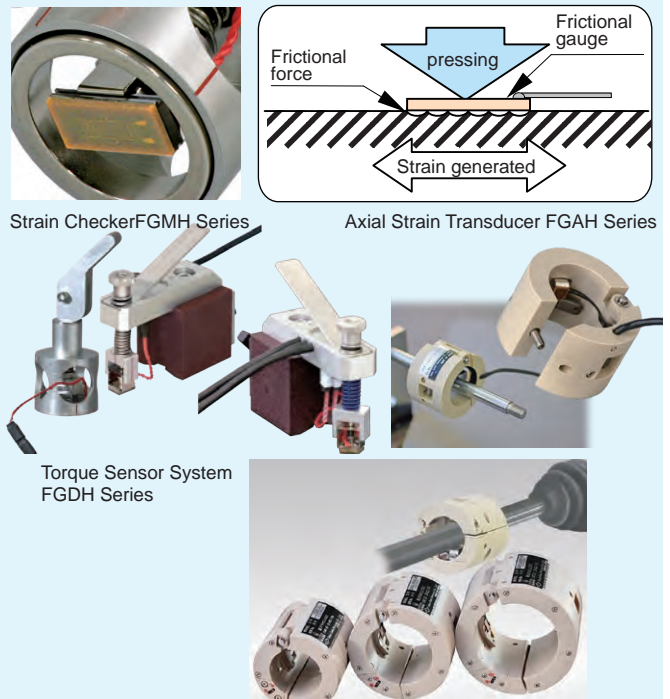

4. Internal strain measurement using embedment type

This strain gauge measures internal strain of concrete, mortar or asphalt by being embedded into the material before its hardening. It makes possible with measurement in the early stage of hardening of the material. Some series of this type are applicable to measurement in asphalt in high temperature of 200°C. We also have a method to measure axial force of bolt by embedding a bolt strain gauge which is specially prepared for this purpose.

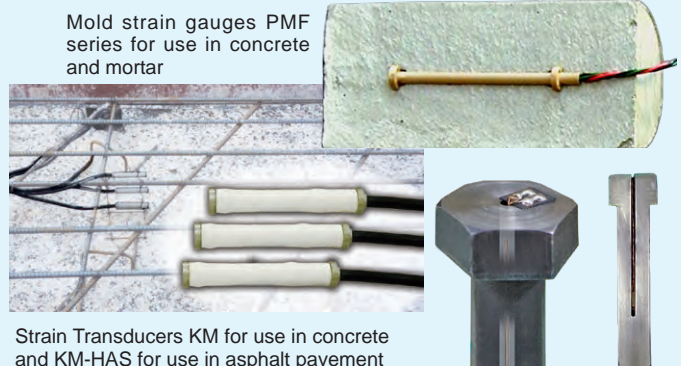







CE marking availability of TML Strain Gauges

- For strain gauges without integral lead wire, the followings are CE marked.
 - * GOBLET:F/QF/BF/GF/LF/YEF series, PF/P/UBF/DSF/CF/CEF/ZF/EF/SF/AW/FAC/BTM series
 - * Some strain gauges other than the above are optionally available with CE marking.
- For strain gauges without integral lead wire, CE marked strain gauges having integral lead wire with "-F" added after the type name of the lead wire are CE marked.

Note) Please contact TML or your local representative for the details of CE marking availability.

Bolt gauge BTM series installed into bolt with bonding adhesive

Strain measuring instruments - Static measurements

Data Logger	Measurement Box	Number of measuring point	Measuring Time [interval for measurement]
High speed • High accuracy • High functionality Data Logger T-ZACCS9 TS-960  Interface: LAN/USB/RS-232C	Built-in Unit	10	High speed : 0.1 seconds (0.1 seconds)/High accuracy : 0.4 seconds (0.4 seconds)
	T-ZACCS BOX EX-50H	1000	High speed : 0.1 seconds (0.1 seconds)/High accuracy : 0.4 seconds (0.4 seconds)
Data Logger	Switching Box	Number of measuring point	Scanning Time [Time required for measurement]
High Performance Data Logger TDS-630  Interface: LAN/USB/RS-232C * : Combination with parallel communication unit PCU-4A	IHW-50H	1000	0.1 seconds : at High speed/On-line mode IHW-50H
	IHW-50G-01*	50	0.1 seconds* : at High speed/On-line mode
	IHW-50G	1000	0.4 seconds/1000 points (0.04 seconds/point) [1 second]
	ISW-50G	1000	2 seconds/1000 points (0.04 seconds/point) [3 seconds] IHW-50G
	ASW-50C SSW-50D	1000	60 seconds/1000 points (0.06 seconds/point) [60 seconds]
	Built-in (High speed)	30	0.1 seconds : at High speed/On-line mode
Data Logger TDS-540  Interface: LAN/USB/RS-232C	IHW-50G	1000	0.4 seconds/1000 points (0.04 seconds/point) [1 second]
	ISW-50G	1000	2 seconds/1000 points (0.04 seconds/point) [3 seconds]
	ASW-50C SSW-50D	1000	80 seconds/1000 points (0.08 seconds/point) [80 seconds]
	Built-in (High speed)	30	0.4 seconds/30 points (0.04 seconds/point) [1 second] SSW-50D
	Built-in (Standard)	30	1.2 seconds/30 points (0.04 seconds/point) [2 second]
T-ZACCS5 Data Logger TS-560  Interface: LAN/USB/RS-232C	IHW-50G	1000	0.4 seconds/1000 points (0.04 seconds/point) [1 second]
	ISW-50G	1000	2 seconds/1000 points (0.04 seconds/point) [3 seconds]
Portable Data Logger TDS-150  Interface: USB/RS-232C LAN (option)	FSW-10	50	4 seconds/50 points (0.08 seconds/point) [4 seconds] FSW-10
	FSW-10L	50	4 seconds/50 points (0.08 seconds/point) [4 seconds] FSW-10L
Handheld Data Logger TC-32K  Interface: : USB/RS-232C	CSW-5B	5	0.4 seconds/5 points (0.08 seconds/point) [1 second] CSW-5B-05
	Not used (TC-32K only)	1	0.08 seconds/1 point (0.08 seconds/point) [1 second] CSW-5B

Data loggers are equipped with functions of calculation, storage and processing of measured data in addition to automatic scanning measurement of multiple points. Not only strain but also voltage and temperature are accepted as measurement objects of data loggers.

Strain measuring instruments - Static measurements

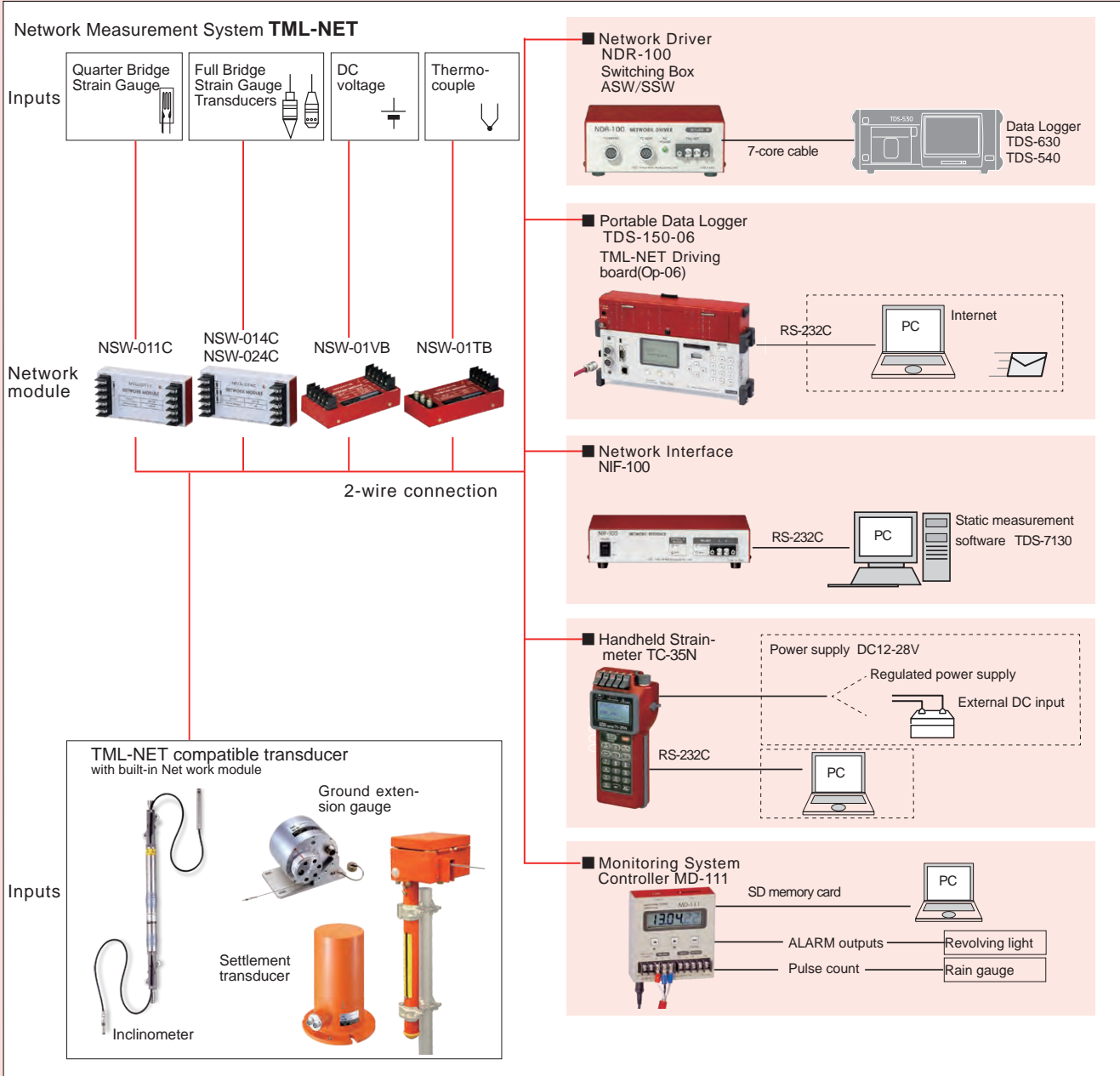

Static Measurement Software TDS-7130v2

for TS-960, TS-560, TDS-630, TDS-540, TDS-150, TC-35N

- Maximum number of data items is 4000 (Including calculation results).
- Rectangular rosette analysis and various numerical operations are possible using expanded channel.
- Number of measuring times is 20 million at the maximum; applicable to long-term continuous measurement.
- Vector monitor and arrow monitor are indicated on graph sheet.

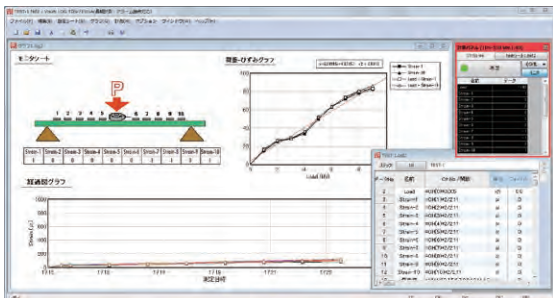

Static Measurement Software Visual LOG Light TDS-700L

for TS-560, TDS-540, TDS-150, TC-32K, TC-35N

- Maximum number of measurement channels is 200.
- Direct writing to a worksheet of Excel is possible.
- For interval timer, 3 tables can be created and executed respectively.
- Simple and quick operation from measurement to data processing possible utilizing Excel functions.

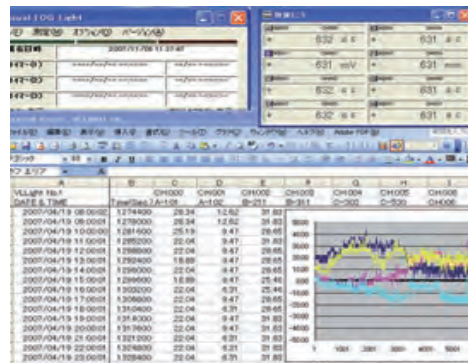

Strain measuring instruments - Dynamic measurements

DIGITAL DYNAMIC STRAINMETER

Type	No. of channels	Bridge Voltage	Frequency Response	Interface	
DRA-162B	16	0.5, 2Vrms 5kHz	DC ~ 2.5kHz	LAN	
DS-50A	50	DC2V	DC ~ 100Hz	LAN	
DC-204R DC-204Ra	4 4	DC0.5, 2V DC0.5, 2V	DC ~ 10kHz DC ~ 10kHz	USB	
DC-004P	4	DC0.5, 2V	DC ~ 2kHz	USB	
DH-14A	4	DC0.5, 2V	DC ~ 1kHz	-	

Multi-Recorder

Type	Number of measuring point	Measurement unit	Frequency response	Interface	
TMR-300	80 at maximum	Strain full bridge unit, Strain 1G2G 4G unit, Carrier type strain unit, Voltage input unit, Voltage output unit, Distribution unit	DC ~ 10kHz	LAN, USB	

ANALOG DYNAMIC STRAINMETER

Type	No. of channels	Bridge Voltage	Frequency Response	
DA-17A	1	0.5, 2Vrms 5kHz	DC ~ 2.5kHz	
DA-18A	1	0.5, 2Vrms 5kHz	DC ~ 2.5kHz	
DA-37A	1	0.5, 2Vrms 20kHz	DC ~ 10kHz	
DA-38A	1	0.5, 2Vrms 20kHz	DC ~ 10kHz	
DC-96A	1	DC0.5, 1, 2, 5, 10V	DC ~ 200kHz	
DC-97A	1	DC0.5, 1, 2, 5, 10V	DC ~ 500kHz	

Dynamic Measurement Software DRA-7630/DC-7630/TMR-7630/RD-7640

- Data monitorings with various styles are possible.
- Graphics in versatile formats including spectrum graphs are possible.
- Rectangular rosette analysis and various numerical operations are possible using expanded channels
- Performs a unified control of condition setting and data.

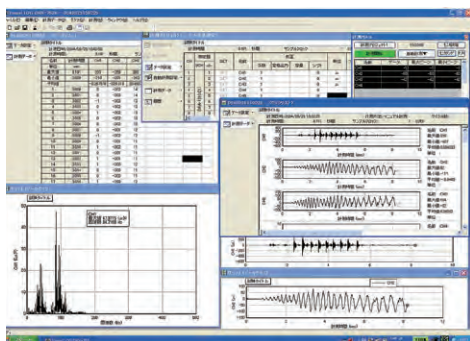

Waveform Display Software WF-7630 for TML Dynamic Measurement Software Data

- Separated files created by free run measurement are merged into one file.
- Cutting out and thinning are possible during CSV conversion of data files.
- Several graphs and objects are arranged in a graph windows.
- Image storage of graph data and CSV files storage of graph values are possible.

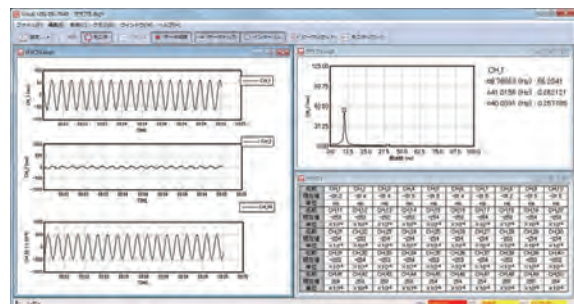

Strain measuring instruments - Dynamic measurements

MULTI-RECORDER TMR-300 SERIES

Small Multi-channel Data Acquisition System Multi-Recorder TMR-300 Series

Number of channels : 80
 Sampling speed :
 Max 100kHz
 Recording media :
 SD card
 (Max.32GB)
 Interface : LAN, USB



Multi-recorder TMR-300 Series is a compact multi-channel data acquisition system that can combine various measurement units according to the purpose of measurement. Due to its compact size and light weight, the system can be easily installed not only on existing structures such as machines and bridges in which the installation space is restricted, but also on moving bodies such as automobiles, aircrafts and ships.

Measurement units for inputting sensors are available in several types for strain gauges, strain gauge type transducers, DC voltage or thermocouples. Control unit is used for controlling 10 measurement units (80 measurement points) at maximum and communicating with a computer. The control unit and the measurement units can be connected together and placed in a small space, or each measurement unit can be installed in the vicinity of the sensors to be inputted.

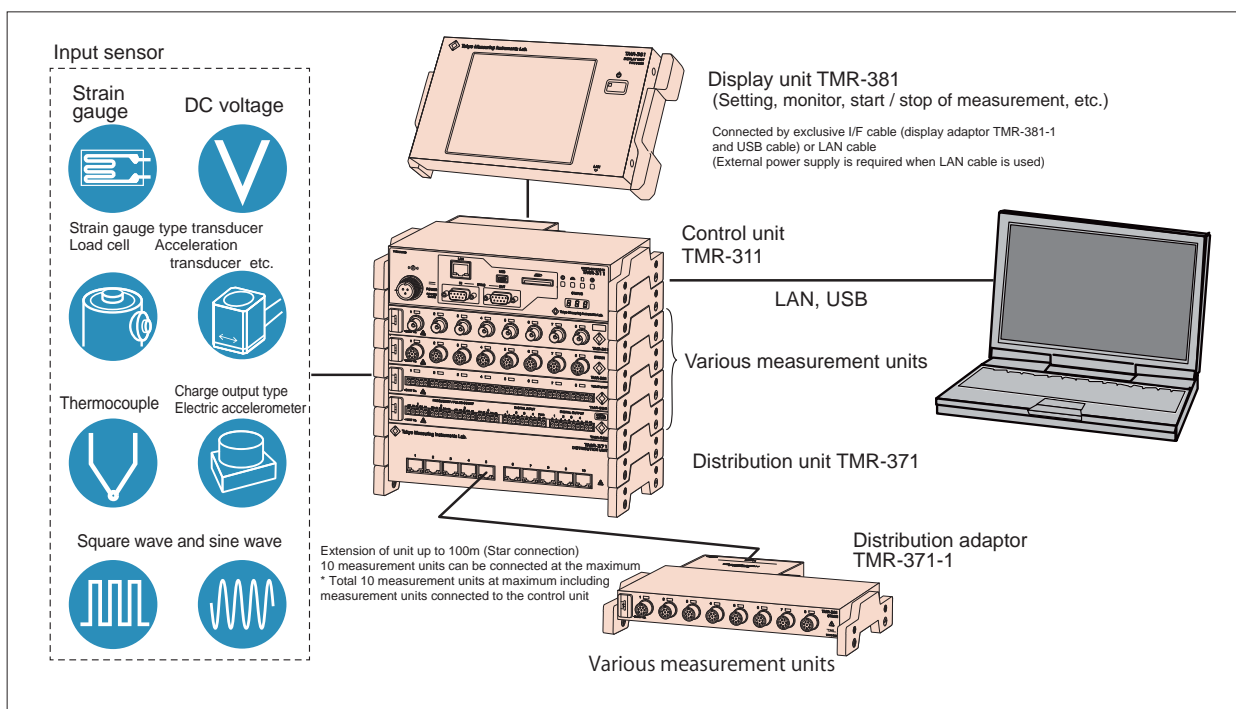

Measuring units



Display Unit TMR-381



Control unit TMR-311

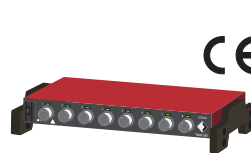

Strain Full Bridge Unit TMR-321



Strain 1G2G4G unit TMR-322



Carrier type strain unit TMR-323



Voltage Input Unit TMR-331



Thermocouple / Voltage Unit TMR-332



Voltage Output unit TMR-341



Distribution unit TMR-371



Digital I/O unit TMR-353



Synchronization unit TMR-372



Charge Amplifier Unit TMR-361



Tokyo Sokki Kenkyujo Co., Ltd. (TML) is accredited by Japan Calibration Service System (JCSS), conformed to international standards JIS Q 17025 (ISO/IEC 17025) under the laboratory accreditation body ISO/IEC 17011. International Accreditation Japan (IA Japan) plays as the accreditation body of JCSS and is a signatory to MRA of Asia Pacific Accreditation Cooperation (APAC) as well as International Laboratory Accreditation Cooperation (ILAC). Our Kiryu factory is certified as a JCSS-accredited laboratory working in compliance with an international Mutual Recognition Arrangement (MRA). The accreditation number of the Kiryu Factory is 0090.



Approval Certificate **ISO9001**
Design and manufacture of
strain gauges, strain measuring
equipment and transducers



Tokyo Measuring Instruments Lab.

URL www.tml.jp/e

8-2, Minami-ohi 6-chome, Shinagawa-ku, Tokyo 140-8560, JAPAN
TEL: +81-3-3763-5614 FAX: +81-3-3763-5713

The contents of this catalog are subject to change without prior notice.
The contents of this catalog are as of June 2021. TML Pam E-2020D