



19120208 A02

This brochure is subject to change without prior notice.
Copyright © Shenzhen Inovance Technology Co., Ltd.
Copyright © Shenzhen Inovance Technology Co., Ltd.

Industrial Automation | Industrial Robot | New Energy Vehicle | Rail Transit

INOVANCE

MD880 High-Performance Engineering AC Drive

Born for Process Automation



Shenzhen Inovance Technology Co., Ltd.
Shenzhen Inovance Technology Co., Ltd.
www.inovance.com

Add.:Inovance Headquarters Tower, High-tech Industrial Park, Guanlan Street, Longhua New District, Shenzhen
Tel.: +86-755-2979 9595 Fax:+86-755-2961 9897
Customer service: 4000-300124

Suzhou Inovance Technology Co., Ltd.
Suzhou Inovance Technology Co., Ltd.
www.inovance.com

Add.:No. 16 Youxiang Road, Yuexi Town, Wuzhong District, Suzhou
Tel.: +86-512-6637 6666 Fax:+86-512-6285 6720
Customer service: 4000-300124



FORWARD, ALWAYS PROGRESSING

About us

Shenzhen Inovance Technology Co., Ltd. (stock code: SZ.300124) is founded in 2003 and has a current stock market value of about RMB 160 billion. Inovance is the key force in developing industrial automation and drive technologies in China and a provider of optical-mechatronicshydraulic-pneumatic integrated solutions covering drive, control, motor, and precision machineeries.

Inovance achieves an annual revenue of RMB 17.945 billion and an operating profit of RMB 3.573 billion in 2021, which grew by 56% and 70% respectively on yoy basis. Headquartered in Shenzhen, Inovance has established multiple production bases in Suzhou, Changzhou, Yueyang, and Nanjing, as well as subsidiaries, resident offices, and service centers in over 20 countries and regions worldwide. As of 2021, Inovance has obtained 2,186 patents and software copyrights. Through continuous investment in R&D, Inovance has enhanced its technical strength in such fields as motor and drive control, industrial control software, electric drive assembly for new energy vehicles, digitalization, and industrial robots.

Inovance is dedicated to the development of core technologies in motor drive and control, power electronics, and industrial Internet communication, with business covering industrial automation, elevator electrical assessories, new energy vehicles, industrial robots, and rail transit. Inovance aims to provide integrated solutions and industry-tailored products based on various industry needs, creating continuous values for customers. The core technologies of Inovance not only covers the information layer, control layer, drive layer, execution layer, and perception layer, but also covers such fields as industrial automation, elevator, new energy vehicle, and trail transit, including:

- ① high performance vector control technology, servo control technology, and high-power IGCT drive technology in the drive layer;
- ② small- to large-scale PLC technology, CNC control technology, robot control technology, and high-speed bus technology in the control layer;
- ③ high-performance servo motor technology, high-efficiency motor technology, high-speed motor and magnetic levitation bearing technology, high-precision encoder design and process technology, precision transmission machine design and process technology, and image recognition technology in the execution layer;
- ④ industrial Internet, edge computing, industrial AI technology in the information layer; and
- ⑤ process technologies in industries including new energy vehicle, elevator, air contioner, air compressor, 3C manufacturing, lithium battery, silicon, crane, injection molding machine, textile, metal product, printing, and packaging.

Inovance has been listed into "CCTV Top 10 Socially Responsible Corporate in Top 50 Listed Companies in China" in 2017, "National Enterprise Technology Center" in 2021, "First Batch of Postdoctoral Workstation in Shenzhen", "Top 100 Innovative Enterprise In Jiangsu", "First Batch of Key R&D Projects in Intelligent Robot in China", and "New Energy Vehicle Power Assembly Engineering Center in Jiangsu".

67 offices in China **400** authorized distributors **2500+** sales and service staff

1020 service centers **6** inventory centers

A comprehensive service network to offer timely response to customer demands



←
Headquarters in Shenzhen
 Headquartered in Shenzhen, with multiple subsidiaries in major cities such as Suzhou and Hongkong

Inovance Be Everywhere

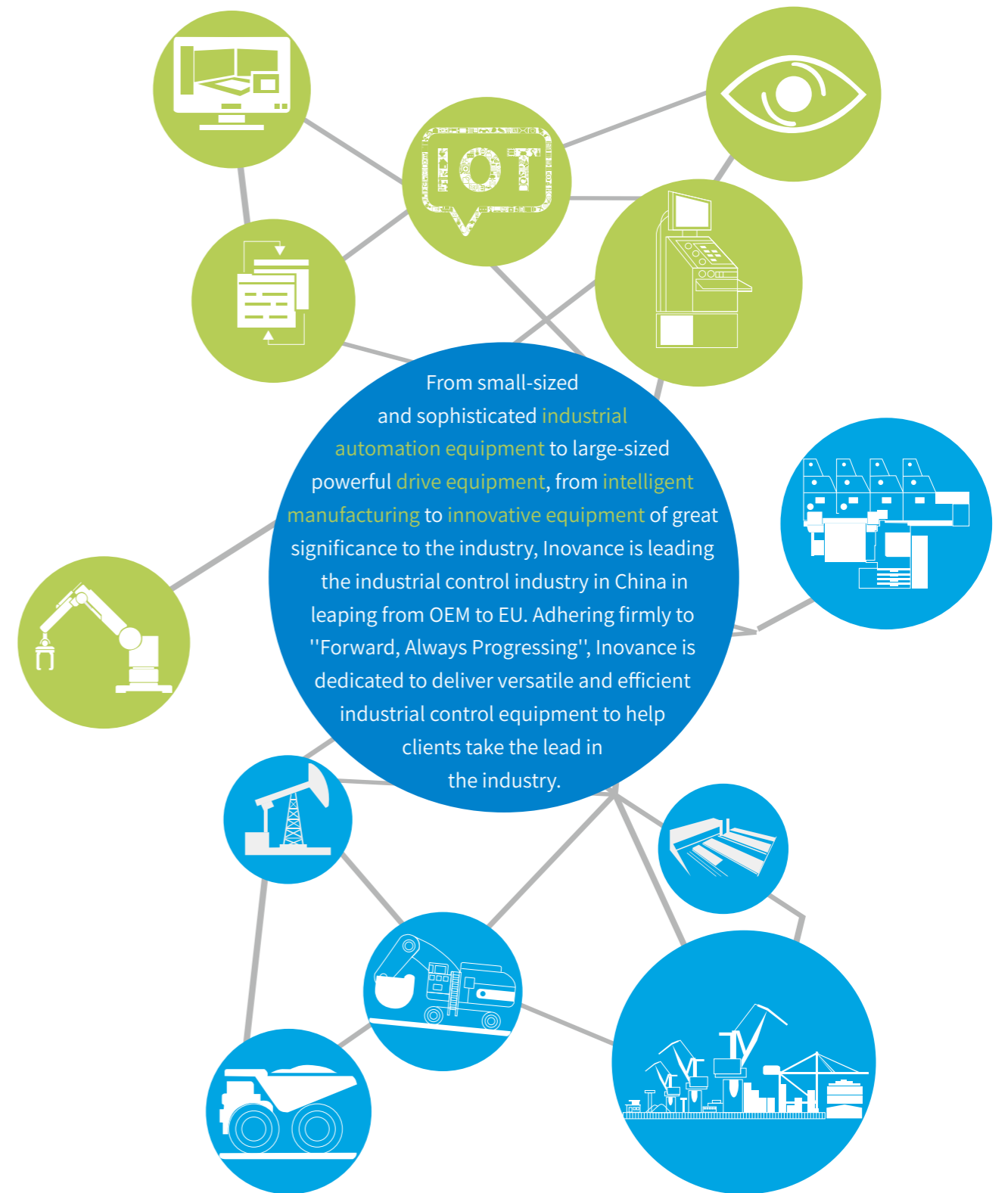

MD880 Series High-Performance Engineering AC Drive A New Benchmark for Engineering Drives Born for Process Automation



Product Overview

MD880 is developed based on high-end AC drive platform of Inovance, which is divided into single-drive system and multi-drive system. Targeting at high-end drive applications, MD880 features high-performance speed and torque control, high reliability, flexible integration, easy commissioning and maintenance, as well as high power density. It sets up a new benchmark for the industry in terms of modular structure, power density, responsiveness, accuracy, and scope of application.

Scope of application

■ Metallurgy

Including high-speed hot strip mills, wide and heavy plate devices, cold roll mills, pickling lines, annealed wires, galvanizing lines, color coating lines, non-ferrous metal alloy manufacturing equipment, non-ferrous rolling equipment, and large-sized metallurgical casting cranes

■ Petroleum

Including marine rig, marine modularized rig, land rig, top drive, mechanical rig retrofit, intelligent electric drive service rig/tractor hoist, electric drive sand blenders

■ Paper-making

Including paper manufacturing equipment, which covers headbox, wite part, press part, dryer part, sizing, hard calendering, coating, super calendering, and rewinder

■ Large-sized port cranes

Including bridge cranes for quayside containers, gantry cranes for RTG containers, grab ship unloaders, grab portal cranes, and large-sized ship-building gantry cranes

■ Vessels

Including electric propulsion, floating cranes, lift, deck machineries, variable-frequency shaft generators

■ Cables

Including large-sized rigid frame stranding machines, tubular stranding machines, and heavy-duty wire drawing machine

■ Test benches

Including test benches for electric vehicles, wind turbine converters, and battery packs

■ Tunnel boring machines

Including tunnel boring machine cutterhead drives, conveyor drives, slurry pump drives, and dredge pump drives

■ Others

Including wind turbine converters, assembling unit test benches, low-voltage power control, pipeline, and mine conveyor equipment

Flexible Modular Design

Flexible configuration of software/hardware modules to fulfill customized needs without changing codes

- ① Fun and free programming
- ② Open data flow graph for easy commissioning
- ③ Flexible configuration with extension cards

01 Fun and free programming

Flexible configuration of control words

Extension card input terminal status, control board input terminal status, drive status word, drive operating status

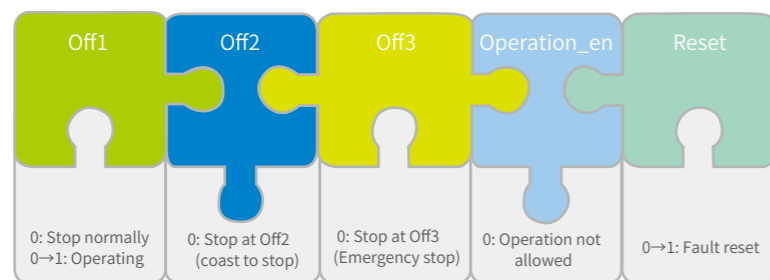

Definition of standard control word

Modular configuration of software

Abundant resource pool that can be called as needed (variable data of each software block, bus process data, speed channel, torque channel, and ramp function generator)



02 Open data flow graph for easy commissioning

- Graphical control flow
- Automatic troubleshooting
- Transparent control solution
- Clear function assignment

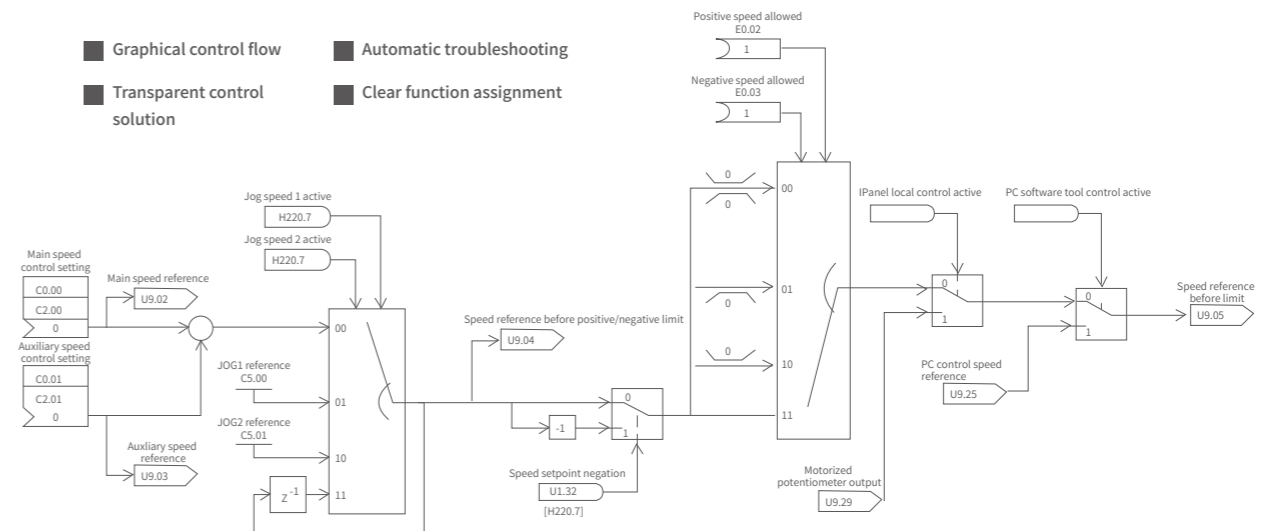

03 Flexible configuration with extension cards

- HCU controller encapsulated separately, with three extension slots available
- Up to seven extension slots extendable
- Multiple types of extension modules supported

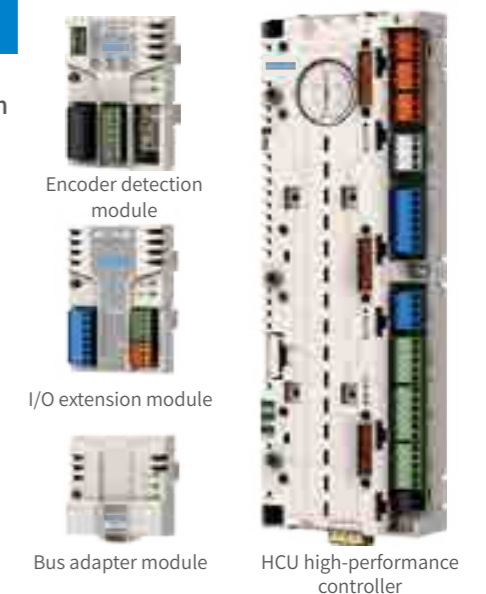

01 Quick troubleshooting on site

- Quick recovery from fault to reduce operation loss of production lines, without the need for replacing HCU controller or disconnecting communication cable, control cable, or encoder cable, or programming backup parameters or system software
- Pluggable SD card in the HCU controller for saving parameters and system software, allowing quick replacement of HCU
- Battery-powered system clock to ensure safe and reliable time stamp of HCU event recorder, without being affected by sudden power failure

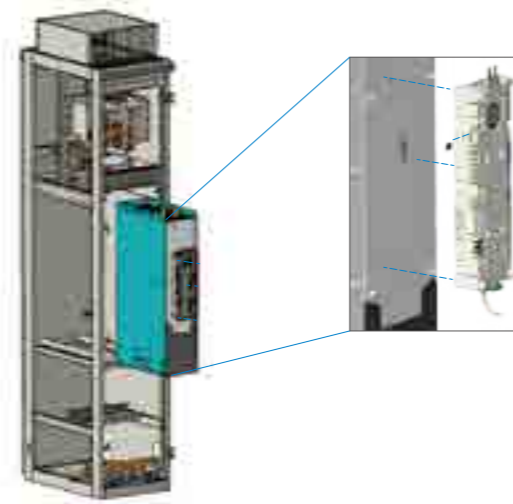

03 Detailed fault log in the black box

- Saving waveform data of 50 monitored objects upon fault
- Saving 1000 groups of data cyclically through re-writing



02 Remote diagnostic service in real time

- Technicians can, after being authorized by the client, connect the remote server on site through VPN to check the fault log, system parameters, and operation data to locate faults quickly and optimize processes to improve efficiency.

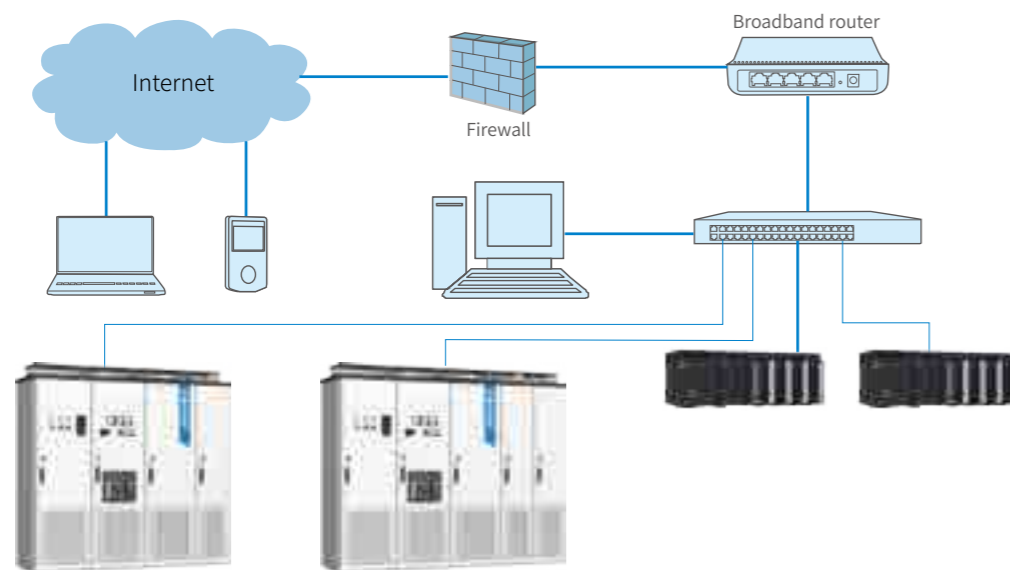

04 Fault levels settable for failsafe operation

- Fault levels determined automatically and displayed in real time through the LCD, with fault analysis generated for guidance

Level 1	Coast to stop at fault
Level 2	Decelerate to stop at fault
Level 3	Derated operation continued at fault
Level 4	Operation continued, with frequency upper limit being limited
Level 5	Operation continued, with restart inhibited
Level 6	Operation continued, with restart allowed
Level 7	Fault/Alarm ignored

- ① Quick troubleshooting on site
- ② Remote diagnostic service in real time
- ③ Detailed fault log in the black box
- ④ Fault levels settable for failsafe operation

Stable operation and reliable performance

Industrial-level hardware configuration for stable long-term operation
Multiple troubleshooting mechanism for quick recovery on site

Outstanding Compatibility

Compatible with various host controllers without changing PLC programs

- ① Compatible with various host controllers
- ② Outstanding motor control performance
- ③ Mounting brackets available as options

01 Compatible with various host controllers

- Powerful digit conversion tool+Parameter interconnection+Bus adapter function to compatible with any bus type, without the need for changing the host controller programs or configuration files

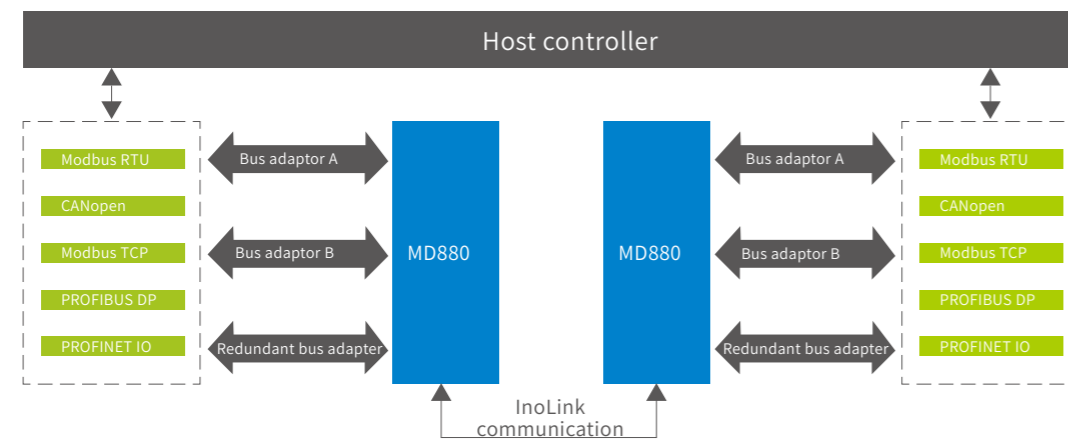

02 Outstanding motor control performance

- Supporting asynchronous and synchronous motor control
- Supporting 150% torque output at 0 Hz without encoder



03 Mounting brackets available as options

- Supporting frame structures with similar interfaces to allow quick replacement on site

01 InoDriveStudio for easy commissioning

InoDriveStudio, a standard PC commissioning software developed for Inovance multi-drive products, features user-friendly interfaces and graphical menus to allow easy configuration, parameter setting, fault detection, system maintenance and service.

InoDriveStudio can deliver up to eight signal trend records, with fault diagnosis and parameter optimization simplified. It helps electrical engineers locate faults quickly through recovering the information of 50 monitored objects generated in the high-speed data recorder of HCU upon fault, optimizing process control of production lines.

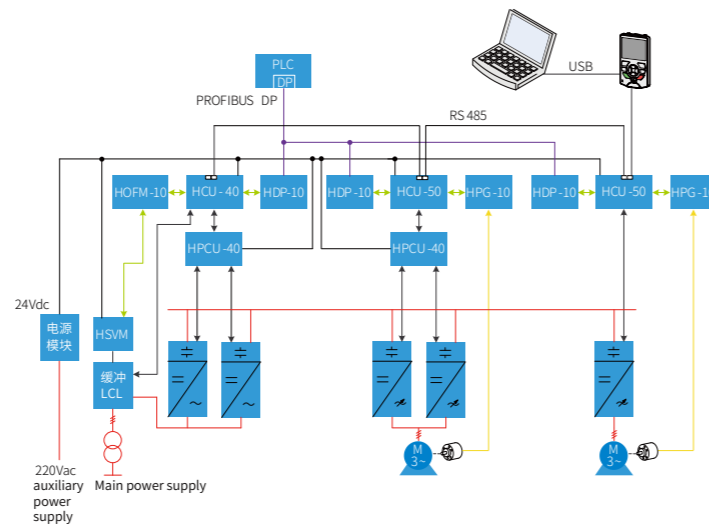

02 SOP-20-880 operating panel for quick commissioning

- LCD
- 240 mm x 160 mm
- PC connected to the AC drive system through USB port in SOP-20-880
- Language: Chinese/English
- Display of eight rows of characters
- Parameter copy and recovery



Structure and Features of MD880 Multi-drive System

Common DC bus

- Reducing the power supply module and braking module current, as well as device capacity
- Supporting direct exchange of generating energy and motoring energy through common DC bus of drive modules during winding/unwinding applications under potential energy load
- Adopting book-sized power supply modules, drive modules, braking modules, and active power supply filter modules for flexible model selection, easy cabinet assembly, and quick maintenance, reducing the consumption of cabinets and saving the footprint by 30% to 60%
- Supporting in-cabinet installation of power modules and options to ensure overall quality of the drive system
- Fulfilling diversified demands from integrators and end users by providing assembly units or cabinets

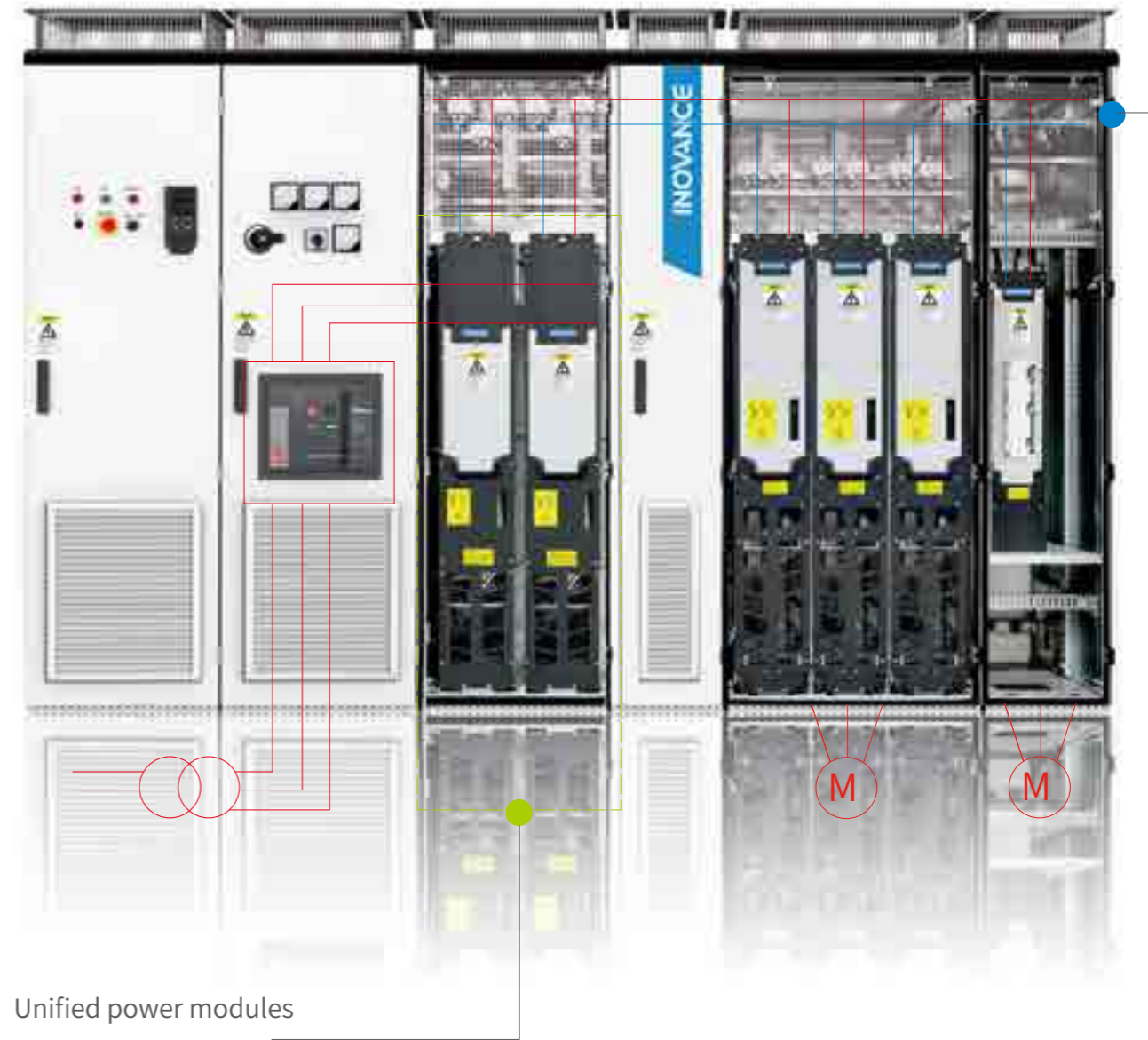

Unified power modules

Unified incoming circuits

- Reducing the consumption of incoming lines and power distribution protection devices
- Improving reliability through ensuring the overall integrity and control functions

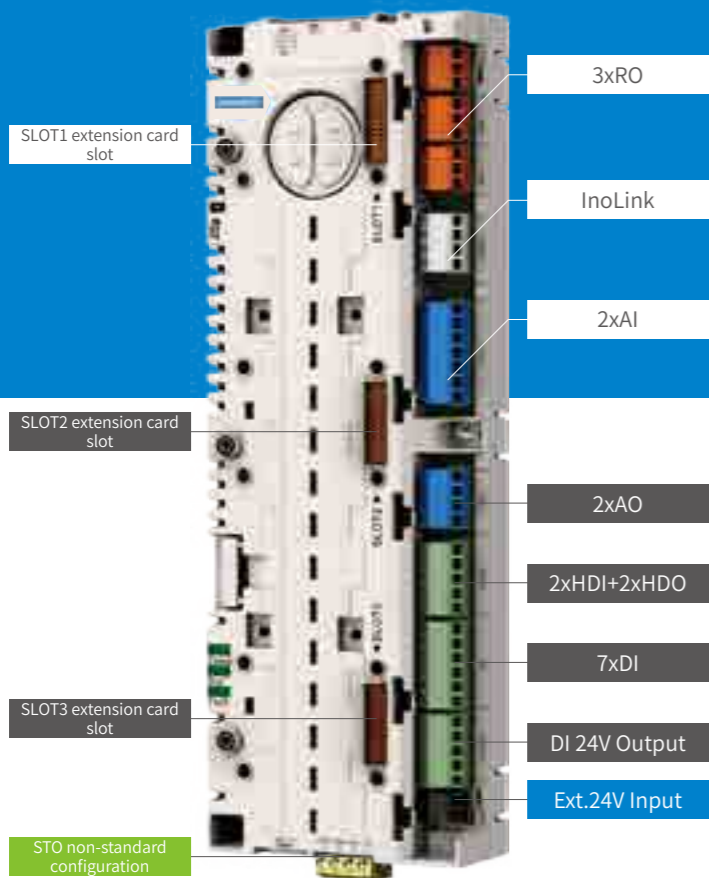

HCU control module, the master controller developed for MD880 series drives with single-drive or multi-drive systems, is mainly used to control basic power supply modules, regenerative power supply modules, active power supply modules, drive modules, and DCDC power modules. It features powerful functions, compact structure, high extendability, high reliability, flexible networking, and excellent control algorithm. For use with drive units, the HCU control module supports synchronous and asynchronous motor control, V/f control, sensorless vector control, and feedback vector control. For use with DCDC modules, the HCU control module supports voltage control, current control, power control, and switchover among different control modes.

High performance
High reliability

HCU Extension Module

Item	I/O Extension Module	Encoder Detection Module	Bus Adapter Module
Photo			
Type	1. I/O extension module (2xDIO+2xAI+2xAO+1RO)	1. HTL incremental encoder detection module 2. Resolver detection module 3. TTL incremental encoder detection module 4. Sin/Cos encoder detection module	Fieldbus adapter module 1. PROFIBUS-DP 2. CANopen 3. Modbus RTU industrial Ethernet module 1. PROFINET IO 2. Modbus TCP 3. EtherCAT Ethernet commissioning module 1. Ethernet commissioning module

Components of HCU Control Module

No.	Name	Description
1	User terminal	User I/O terminals are included as standard.
2	Communication optical fiber	Used as the optical fiber communication interface between HCU and power module.
3	STO terminal	Safe torque off (STO)
4	Slot 1	Extension module interface
5	Slot 2	Extension module interface
6	Slot 3	Extension module interface
7	Battery cover	RTC backup battery cover
8	Operating panel terminal	Two RJ45 terminals with the same assignment for easy cascading
9	SD card	Used as the standard memory of HCU, which can be inserted flexibly
10	Safety module slot	Used as the dedicated slot for functional safety module
11	Indicator	Indicates the state of the power supply, operation, and fault
12	Function module SIZE1	105 x 73 x 24 (mm)
13	Function module SIZE2	75 x 73 x 24 (mm)
14	Intelligent operating panel	SOP-20-880
15	Fixing hole	Three fixing holes for HCU

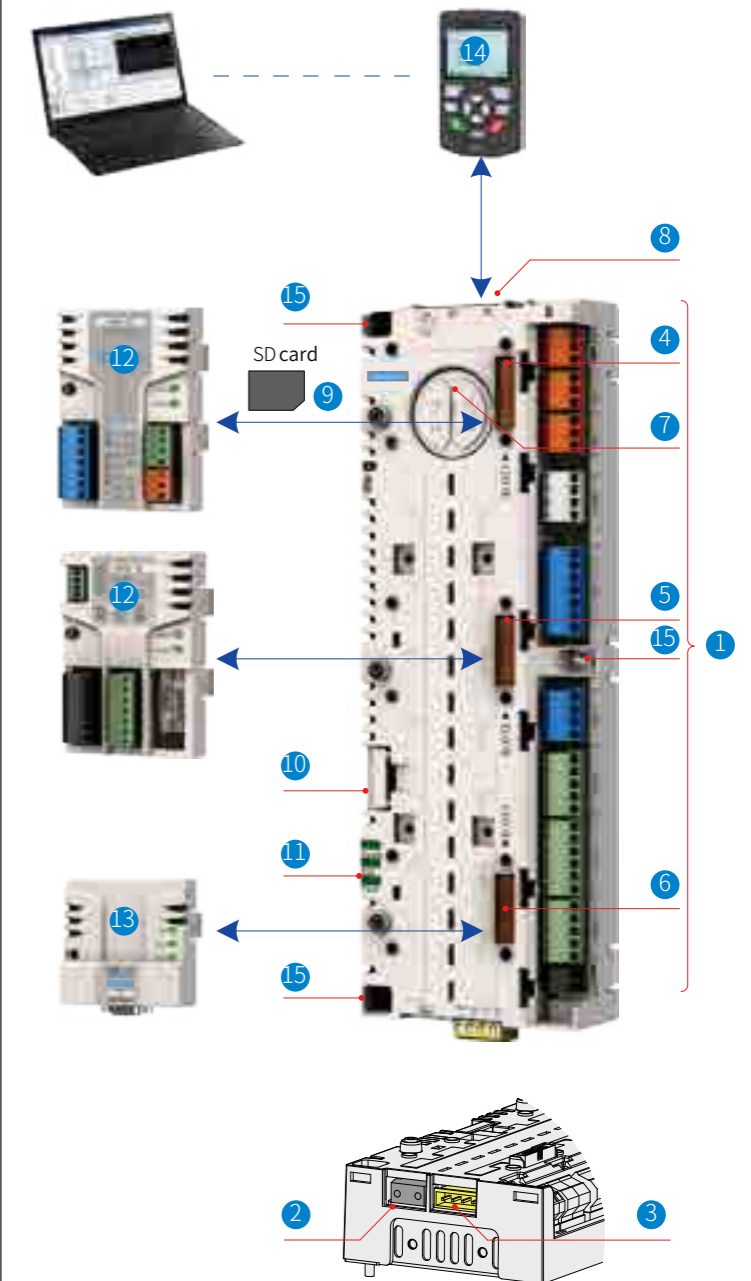

MD880 Series Products

Naming rules for single-drive products



MD880 - **01S** - **XXXX** - **4** - **L** - **SG**
 ① ② ③ ④ ⑤ ⑥

① MD880 AC drive series	② 01S: AC drive (single-drive system) 11S: AC drive cabinet (single-drive system) ¹	③ XXXX: Rated current
④ 4: 400 V 7: 690 V	⑤ L: With output reactor B: Built-in braking unit _: Without reactor or braking unit	⑥ SG: 2nd generation of controller

※1: For AC drive cabinets with single-drive system, only 690 V standard cabinets are available.

MD880 400 V Single-Drive Series

Item	MD880 Series AC Drive (Single-Drive System)					
Photo						
Frame Size	T2	T3	T4	T5	T6	T7
Voltage Class	Three-phase 400 VAC (range: 380 VAC to 480 VAC)					
Power Rating	5.5–7.5 kW	11–15 kW	18.5 kW	22–30 kW	37–45 kW	55–75 kW
Max. Weight (kg)	8.5	11	12.2	17.6	27.6	37.5
Dimensions in mm (W x D x H)	140 x 338 x 450	150 x 348 x 470	190 x 348 x 470	230 x 357 x 500	265 x 387 x 510	300 x 425 x 542

Item	MD880 Series AC Drive (Single-Drive System)				
Photo					
Frame Size	T8	T9	T10	T11	T12
Voltage Class	Three-phase 400 VAC (range: 380 VAC to 480 VAC)				
Power Rating	90–132 kW	160–200 kW	220–250 kW	280–315 kW	355–450 kW
Max. Weight (kg)	54	87.5	110 160 (-L)	155 215 (-L)	185 245 (-L)
Dimensions in mm (W x D x H)	338 x 465 x 580	400 x 470 x 915	360 x 500 x 1134 360 x 500 x 1472 (-L)	390 x 545 x 1284 390 x 545 x 1622 (-L)	400 x 545 x 1403 400 x 545 x 1735 (-L)

※Note: (-L) indicates an output reactor is included.

MD880 690 V Single-Drive Series

Item	690 VAC High-Performance AC Drive (Single-Drive System)		
Photo			
	MD880-01S-0600-7-SG	MD880-01S-0650-7-SG	MD880-01S-0721-7-SG
Voltage Class	Three-phase 690 VAC (range:525 VAC to 690 VAC)		
Power Rating	560 kW	630 kW	710 kW
Max. Weight (kg)	180		
Dimensions in mm (W x D x H)	315 x 588 x 1502		

Item	690 VAC Drive Cabinet (Single-Drive System)			
Photo				
	Frame Size	MD880-11S-0600-7	MD880-11S-0650-7	MD880-11S-0721-7
Voltage Class	Three-phase 690 VAC (range: 525 VAC to 690 VAC)			
Power Rating	560 kW		630 kW	710 kW
Max. Weight (kg)	530			
Dimensions in mm (WxDxH)	853 x 729 x 2058			
Configuration	Input reactor as standard, output reactor and braking unit as options			
Frame Size	MD880-11S-1140-7	MD880-11S-1235-7	MD880-11S-1370-7	
Voltage Class	Three-phase 690 VAC (range: 525 VAC to 690 VAC)			
Power Rating	1100 kW		1200 kW	1300 kW
Max. Weight (kg)	920			
Dimensions in mm (WxDxH)	1353 x 718 x 2058			
Configuration	Input and output reactors as standard, braking unit as option			

Dimensions and Technical Data of MD880 400 V Single-Drive Series

Dimensions of frame sizes T2 to T9

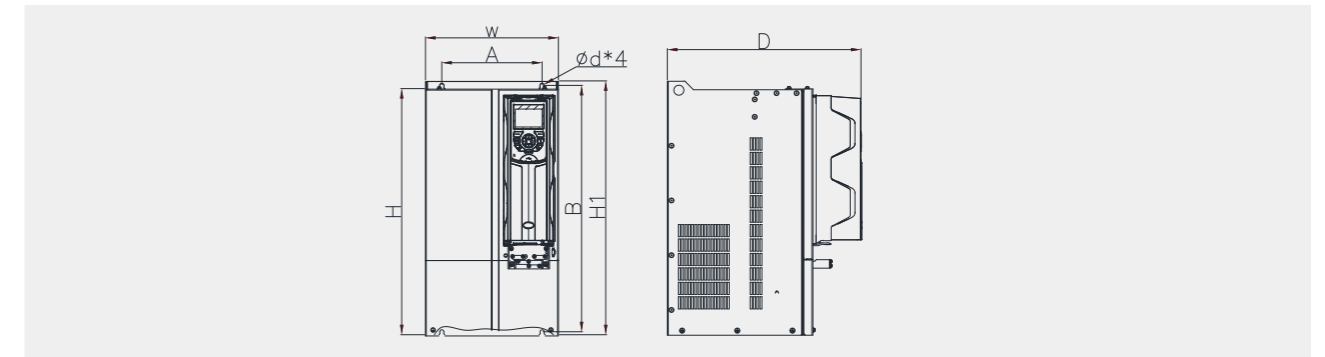

Frame Size	Mounting Hole (mm)		Outline Dimensions (mm)				Mounting Hole Diameter (mm)	Weight (kg)
	A	B	H	H1	W	D		
T2	90	435	433	450	140	338	φ8	8.5
T3	90	455	453	470	150	348	φ8	11
T4	140	455	463	470	190	348	φ8	12.2
T5	170	485	484.5	500	230	357	φ8	17.6
T6	200	495	493	510	265	387	φ8	27.6
T7	245	523	525	542	300	425	φ10	37.5
T8	270	560	554	580	338	465	φ10	54
T9	320	890	874	915	400	470	φ10	87.5

Dimensions of frame sizes T10 to T12

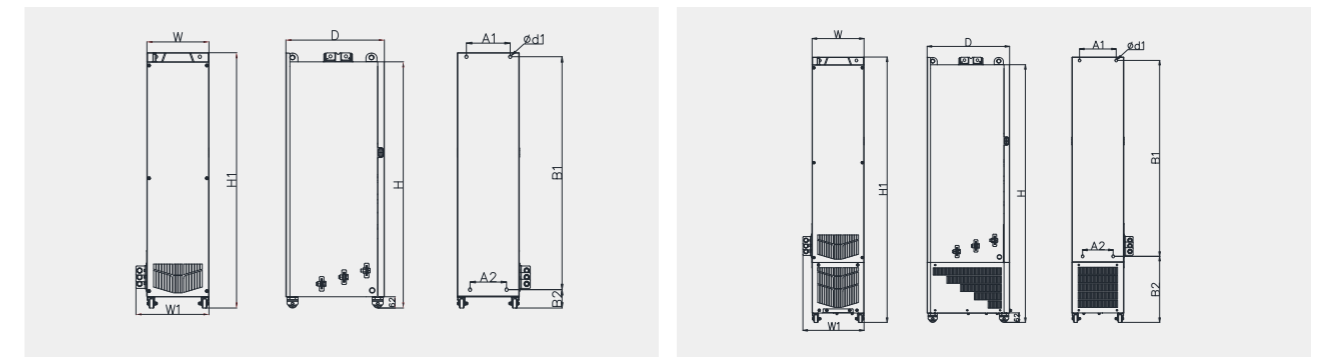

Frame Size	Mounting Hole (mm)				Outline Dimensions (mm)					Mounting Hole Diameter (mm)	Weight (kg)
	A1	A2	B1	B2	H	H1	W	W1	D		
T10	240	150	1035	86	1086	1134	300	360	500	φ13	110
T11	225	185	1175	97	1249	1284	330	390	545	φ13	155
T12	240	200	1280	101	1353	1403	340	400	545	φ16	185
T10 (with reactor)	240	150	1035	424	1424	1472	300	360	500	φ13	160
T11 (with reactor)	225	185	1175	435	1586	1622	330	390	545	φ13	215
T12 (with reactor)	240	200	1280	432	1683	1735	340	400	545	φ16	245

Dimensions and Technical Data of MD880 400 V Single-Drive Series

Technical data

Frame Size	AC Drive Model	Normal Duty Without Overload		Light-Overload Application		Heavy-Overload Application		Outline Dimensions in mm (WxDxH)	Weight (kg)	Power Loss (kW)
		Current (A)	Power (kW)	Current (A)	Power (kW)	Current (A)	Power (kW)			
Un: Three-phase 400 VAC (range: 380 VAC to 480 VAC)										
T2	MD880-01S-0012-4-B-SG	12.0	5.5	12.0	5.5	9.0	3.7	140 x 338 x 450	8.5	0.12
	MD880-01S-0017-4-B-SG	17.0	7.5	17.0	7.5	13.0	5.5			0.195
T3	MD880-01S-0024-4-B-SG	24.0	11.0	23.0	11.0	17.0	7.5	150 x 348 x 470	11	0.262
	MD880-01S-0033-4-B-SG	33.0	15.0	32.0	15.0	25.0	11			0.445
T4	MD880-01S-0038-4-B-SG	38.0	18.5	37.0	18.5	32.0	15	190 x 348 x 470	12.2	0.553
T5	MD880-01S-0048-4-B-SG	48	22	45	22	37	18.5	230 x 357 x 500	17.6	0.478
	MD880-01S-0060-4-B-SG	60	30	58	30	45	22			0.551
T6	MD880-01S-0078-4-B-SG	78	37	75	37	60	30	265 x 387 x 510	27.6	0.694
	MD880-01S-0094-4-B-SG	94	45	91	45	75	37			0.815
T7	MD880-01S-0116-4-B-SG	116	55	112	55	91	45	300 x 425 x 542	37.5	1.01
	MD880-01S-0149-4-B-SG	149	75	143	75	112	55			1.21
T8	MD880-01S-0183-4-B-SG	183	90	176	90	150	75	338 x 465 x 580	54	1.57
	MD880-01S-0217-4-SG	217	110	210	110	176	90			1.81
	MD880-01S-0262-4-SG	262	132	253	132	210	110			2.14
T9	MD880-01S-0314-4-SG	314	160	304	160	253	132	400 x 470 x 915	87.5	2.85
	MD880-01S-0383-4-SG	383	200	370	200	304	160			3.56
T10	MD880-01S-0441-4-SG	441	220	426	220	377	200	360 x 500 x 1134	110	4.15
	MD880-01S-0481-4-SG	481	250	465	250	426	220			4.55
	MD880-01S-0441-4-L-SG	441	220	426	220	377	200	360 x 500 x 1472	160	4.15
	MD880-01S-0481-4-L-SG	481	250	465	250	426	220			4.55
T11	MD880-01S-0538-4-SG	538	280	520	280	465	250	390 x 545 x 1284	155	5.06
	MD880-01S-0605-4-SG	605	315	584	315	520	280			5.33
	MD880-01S-0538-4-L-SG	538	280	520	280	465	250	390 x 545 x 1622	215	5.06
	MD880-01S-0605-4-L-SG	605	315	584	315	520	280			5.33
T12	MD880-01S-0673-4-SG	673	355	650	355	585	315	400 x 545 x 1403	185	5.69
	MD880-01S-0751-4-SG	751	400	725	400	650	355			6.31
	MD880-01S-0849-4-SG	849	450	820	450	725	400			6.91
	MD880-01S-0673-4-L-SG	673	355	650	355	585	315	400 x 545 x 17	245	5.69
	MD880-01S-0751-4-L-SG	751	400	725	400	650	355			6.31
	MD880-01S-0849-4-L-SG	849	450	820	450	725	400			6.91

Dimensions and Technical Data of MD880 690 V Single-Drive Series

Dimensions of frame size S12

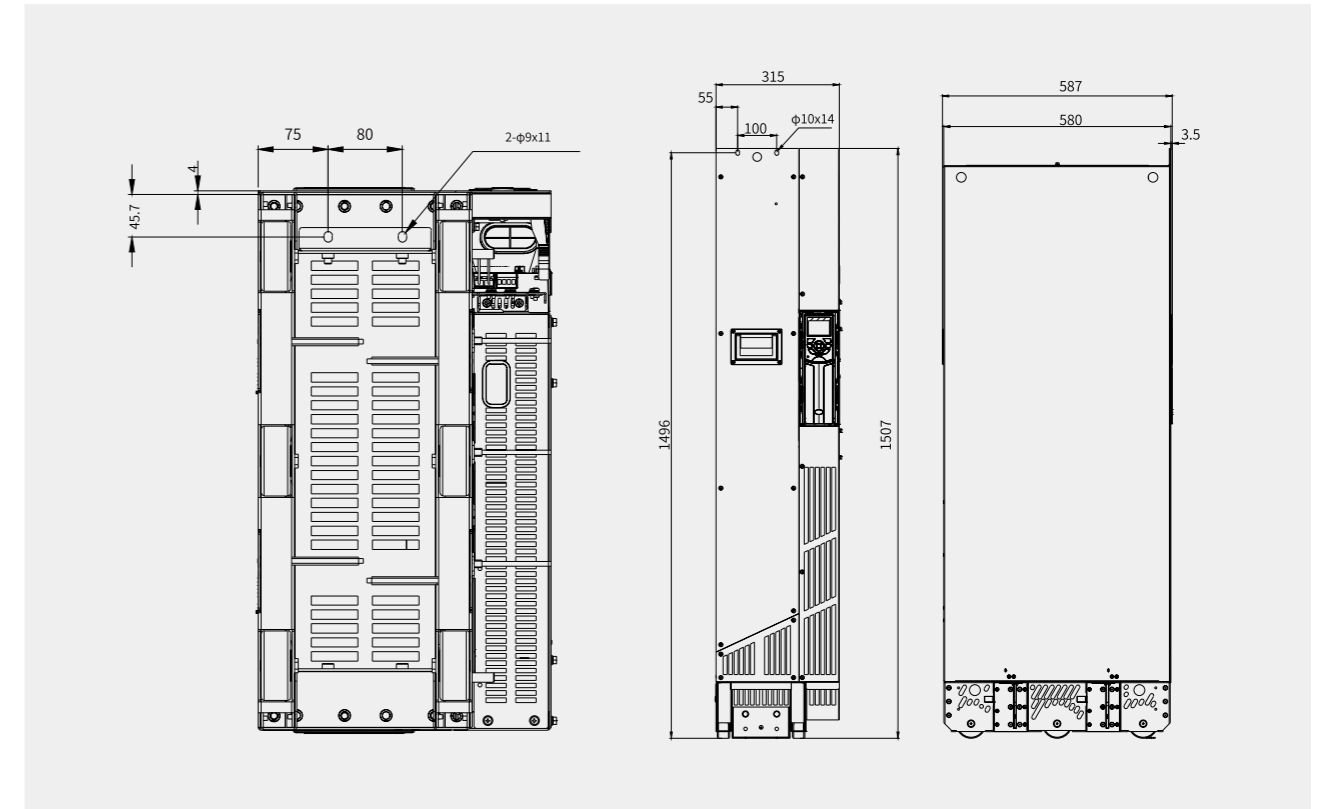

Technical data

Model: MD880-01S- xxxx-x-SG	Rated Output Value							Outline Dimensions in mm (WxDxH)	Weight (kg)	Power loss (kW)
	Normal Duty Without Overload			Light-Overload Application		Heavy-Overload Application				
	I_N	P_N	S_N	I_{LN}	P_{LN}	I_{HD}	P_{HD}			
	A	kW	kW	A	kW	A	kW			
UN: Three-phase 690 VAC (range: 525 VAC to 690 VAC)										
0600-7	600	560	717	576	560	450	400	315 x 588 x 1502	180	9.52
0650-7	650	630	777	624	630	488	450			10.71
0721-7	721	710	862	692	710	541	500			12.07

Dimensions and Technical Data of MD880 690 V Single-Drive Series

Dimensions of 690 VAC drive cabinets (single-drive system)

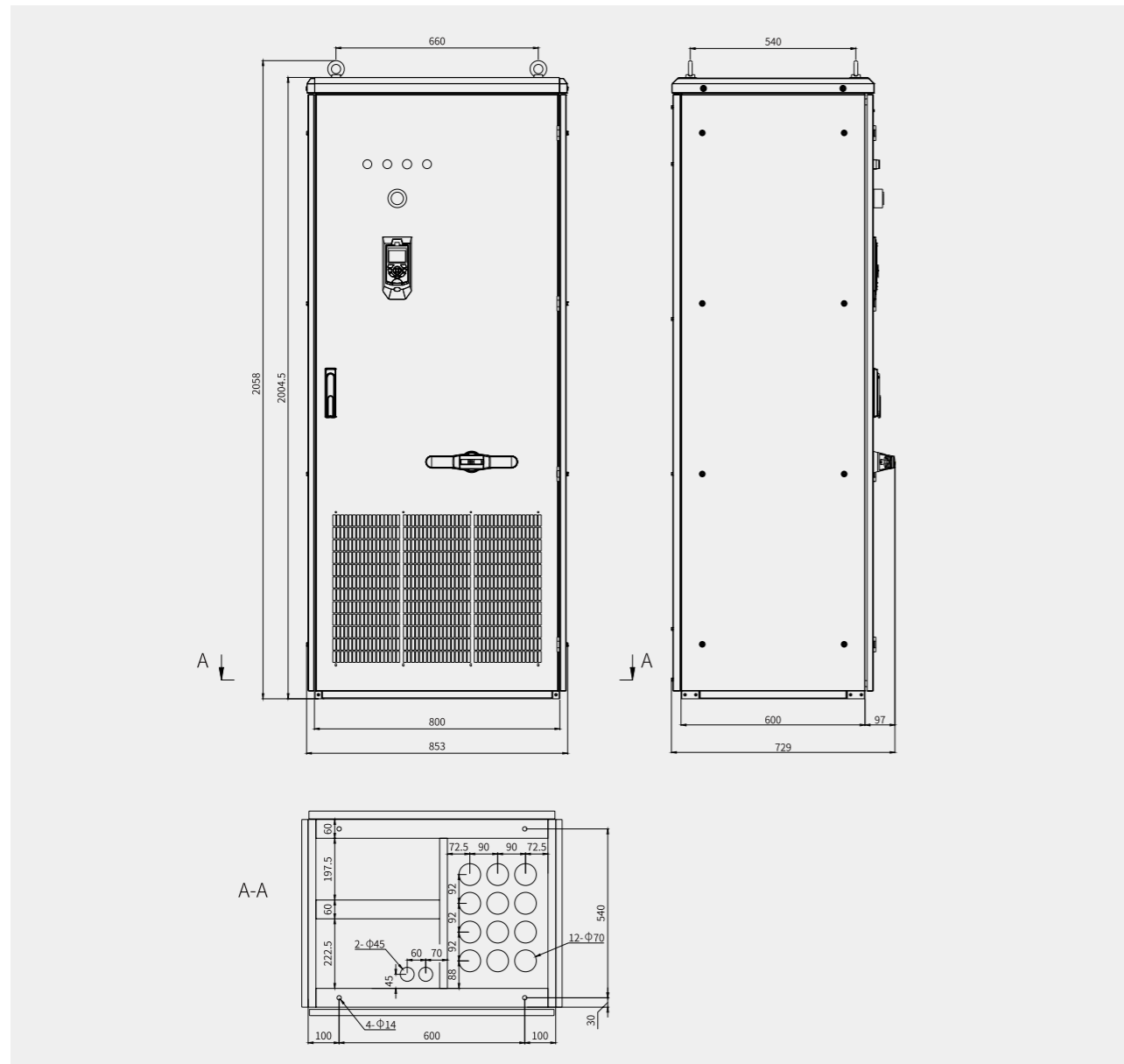

Technical data

Model: MD880-11S- xxxx-x	Frame Size	Normal Duty Without Overload		Light-Overload Application		Heavy-Overload Application		Weight (kg)	Power Loss (kW)	Air Volume (CMM)	Outline Dimensions in mm (WxDxH)
		Current (A)	Power (kW)	Current (A)	Power (kW)	Current (A)	Power (kW)				
UN: Three-phase 690 VAC (range: 525 VAC to 690 VAC)											
0600-7	S12	600	560	576	560	450	400	530	11.39	1190	853 x 729 x 2058
0650-7		650	630	624	630	488	450		12.62		
0721-7		721	710	692	710	541	500		14.06		

690 VAC Paralleled-Module Cabinets

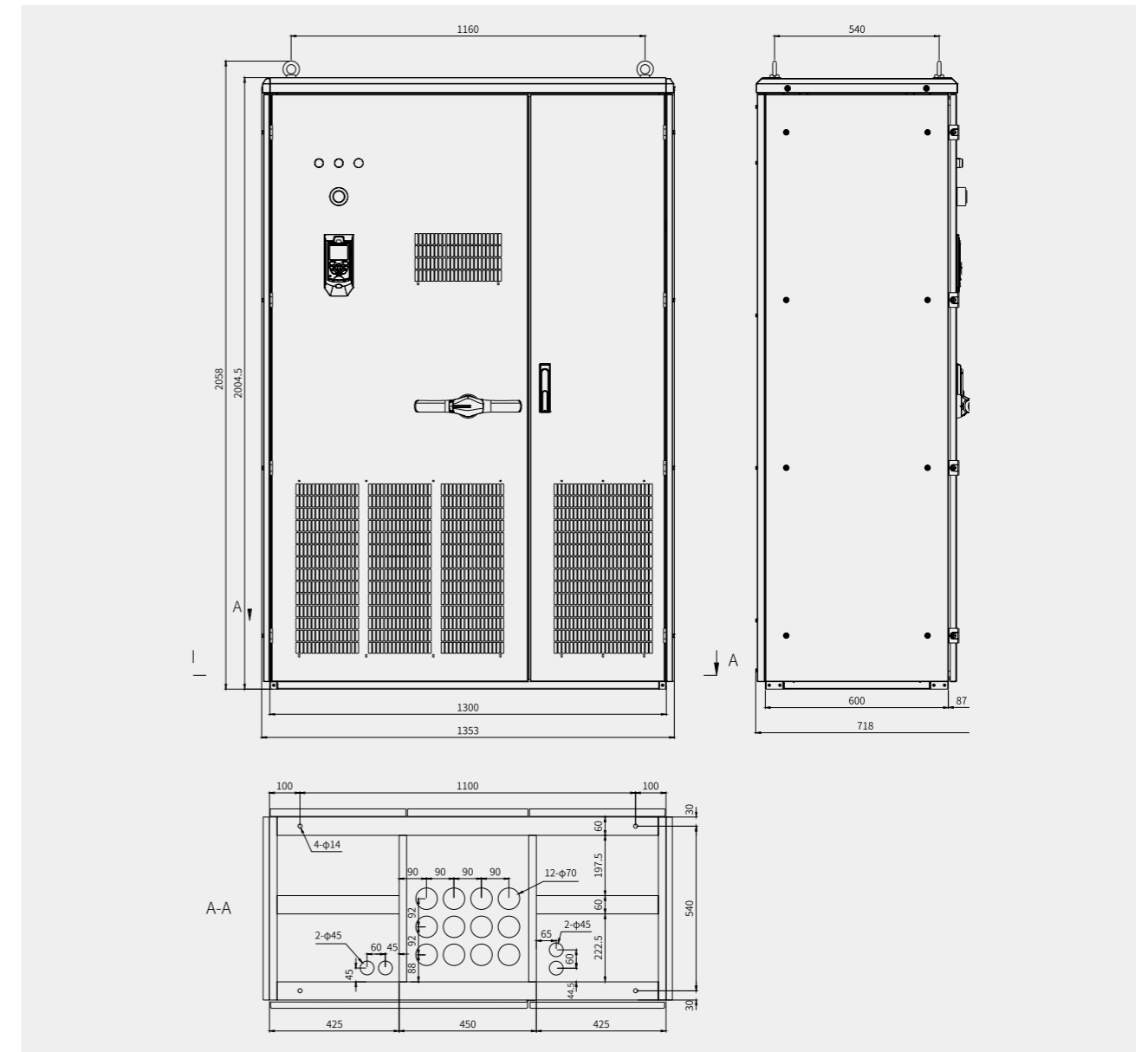

Technical Data

Model MD880-11S- xxxx-x	Frame Size	Normal Duty Without Overload		Light-Overload Application		Heavy-Overload Application		Weight (kg)	Power Loss (kW)	Air Volume (CMM)	Outline Dimensions in mm (WxDxH)
		Current (A)	Power (kW)	Current (A)	Power (kW)	Current (A)	Power (kW)				
UN: Three-phase 690 VAC (range: 525 VAC to 690 VAC)											
1140-7	2*S12	1140	1100	1094	1050	855	800	920	21.99	2350	1353 x 718 x 2058
1235-7		1235	1200	1186	1150	926	900		24.47		
1370-7		1370	1300	1315	1300	1027	1000		27.29		

MD880 Series Products

Naming Rules



MD880 - 50M - XXXX - 4 - SG - N

① ② ③ ④ ⑤ ⑥

<p>① MD880 AC drive series MD880: Air-cooled MD880LC: Water-cooled</p>	<p>② 20M: Basic power supply module 30M: Regenerative power supply module 40M: Active power supply module 50M: Drive module 60M: 3-PH braking module 61M: 1-PH braking module 80M: DCDC module</p> <p>30F: Regenerative power supply filter module 40F: Active power supply filter module 30K: Regenerative power supply frame 40K: Active power supply frame 40D: Low-power active power supply (with filter system) 80D: DCDC (with output filter system)</p>	<p>③ XXXX: Rated current (Rated power for 60M/61M series)</p>
<p>④ 4: 400 V 5: 500 V 7: 690 V</p>	<p>⑤ SG: 2nd generation of controller</p>	<p>⑥ N: H8A module without quick-plug structure or output reactor</p>

MD880 Multi-Drive Series Power Module

Item	Inverter Module						Basic power supply module
Photo							
Frame Size	H1-H3	H4	H6	H7	H8	H8A	T2
Power Rating	380-415 V: H1: 3.7-11 kW H2: 15-22 kW H3: 30-45 kW	380-415 V: 55-90 kW	380-415 V: 110-132 kW 525-690 V: 55-160 kW	380-415 V: 160-200 kW 380-500 V: 250 kW 525-690 V: 200-250 kW	380-415 V: 250-500 kW 525-690 V: 315-710 kW	380-15 V: 250-500 kW 380-500 V: 400-560 kW 525-690 V: 315-710 kW	380-415 V: 475-649 kW 525-690 V: 650-929 kW
Function Type	DC/AC drive module	DC/AC drive module	DC/AC drive module	DC/AC drive module	DC/AC drive module	DC/AC drive module	AC/DC drive module
Max. Weight (kg)	11	20	35	45	130	80	188
Dimensions in mm (WxDxH)	100 x 413 x 415	200 x 413 x 415	180 x 438 x 770	180 x 463 x 920	230 x 582 x 1395	230 x 582 x 939	230 x 602 x 1393

Item	Active power supply frame units		Regenerative power supply frame units	
Photo				
Frame Size	BLCL+H8	BLCL+2 x H8	L+H8	L+2 x H8
Power Rating	380-415 V: 394-556 kW 380-500 V: 463-694 kW 525-690 V: 437-639 kW	380-415 V: 749-1056 kW 380-500 V: 880 kW 525-690 V: 829-1214 kW	380-415 V: 423-595 kW 525-690 V: 684-1026 kW	380-415 V: 787-1106 kW 525-690 V: 1272-1909 kW
Function Type	AC/DC power supply module	AC/DC power supply module	AC/DC power supply module	AC/DC power supply module
Max. Weight (kg)	460	650	320	480
Dimensions in mm (WxDxH)	631 x 624 x 1450	874 x 624 x 1450	631 x 624 x 1450	874 x 624 x 1450

Item	Water-cooled Diode Power Supply Module	Water-cooled Active Power Supply Module	Water-cooled Drive Module	Water-cooled Single-Drive
Photo				
Frame Size	D3D	H7 (LC)	H7 (LC)	H7 (LC)
Power Rating	525–690 V: Rated output: 2273 kW	525–690 V: 627–729 kW	525–690 V: 340–650 kW	525–690 V: 340–530 kW
Function Type	AC/DC power supply module	AC/DC power supply module	DC/AC drive module	AC/DC/AC converter
Max. Weight (kg)	26.5	49	49	55
Dimensions in mm (WxDxH)	540 x 330 x 172	230 x 456 x 720	230 x 456 x 720	230 x 456 x 720

Item	Single-phase Braking Module	DC Chopper	Three-phase Braking Module
Photo			
Frame Size	MD880-61M	H3/H4/H6/H7/H8A	H8
Power Rating	690 V system: Normal duty without overload: 147 kW Heavy overload: 298 kW Quick overload: 404 kW	400 V system: 50–500 kW 500 V system: 300 kW 690 V system: 100–600 kW	400 V system: Normal duty without overload: 500–750 kW Heavy overload: 640–800 kW 690 V system: Normal duty without overload: 870–1300 kW Heavy overload: 1110–1390 kW
Function Type	Single-phase braking module	DC/DC converter	Three-phase braking module
Max. Weight (kg)	11	80	130
Dimensions in mm (WxDxH)	240 x 176 x 460	H3: 100 x 413 x 415 H4: 200 x 413 x 415 H6: 180 x 438 x 770 H7: 180 x 463 x 920 H8A: 230 x 582 x 939	230 x 582 x 1395

MD880 Series Products

Control system and function module options

No.	Name	Model	Description
1	Control module	HCU-20	Basic power supply control module
		HCU-30	Regenerative power supply control module
		HCU-40	Active power supply control module
		HCU-50S	2nd generation of drive control module
		HCU-60	Three-phase braking control module
		HCU-80	DC chopper control module
2	Paralleled-module control module	HPCU-40	2 to 4 paralleled modules supported
		HPCU-60	2 to 6 paralleled modules supported
		HPCU-A0	2 to 10 paralleled modules supported
3	Function extension module	HESD-10	Extension of 1 slot supported
4	Voltage/Current detection module	HSVM-10	Three-phase AC input voltage detection
		HSVM-20	Voltage/Current detection module (1-channel voltage and 2-channel current supported)
		HSVM-30	Voltage/Current detection module (2-channel voltage and 2-channel current supported)
5	Encoder detection module	HPG-10	HTL incremental differential, single-ended, OC or OE encoder detection, frequency-division output
		HPG-30	Sin/Cos encoder detection module
		HPG-40	Resolver detection
		HPG-50	TTL incremental OC or differential encoder detection, frequency-division output
6	Inobus optical fiber extension module	HOFM-10	1 pair of 50 M optical fiber extension module
		HOFM-30	3 pairs of 50 M optical fiber extension module
7	Intelligent operating panel	SOP-20-880	Operating panel for commissioning and monitoring
8	Fieldbus adapter module	HCAN-10	CANopen fieldbus adapter
		HMBA-10	Modbus RTU fieldbus adapter
		HDP-10	PROFIBUS-DP fieldbus adapter
9	Industrial Ethernet module	HPFN-10	PROFINET IO industrial Ethernet
		HMBT-10	Modbus TCP industrial Ethernet
		HETC-10	EtherCAT industrial Ethernet
10	Ethernet commissioning module	HETN-10	Ethernet commissioning module
11	Optical fiber router module	HOFR-50	Information exchange of 2 to 5 HCU controllers (master/slave communication achieved through optical fibers)
12	I/O extension module	HIO-10	2 AIs; 2 AO2; 2 DI0s; 1 relay output
13	Process data collection module	HIBA-10	PDA collection module
14	Remote service gateway	HGW-10	Centralized monitoring module

Comprehensive Technical Data for MD880

Item	Description	
Basic power supply module	Input voltage	4: 380–415 VAC, 7: 525–690 VAC; -10% to +10% (-15%, < 1 min)
	Input frequency range	47–63 Hz
	Output voltage	4: 540–590 VDC, 7: 740–975 VDC
	Overload capacity	Light overload: Continuous operation of 1 min allowed for 110% x rated load every 5 min; Heavy overload: Continuous operation of 1 min allowed for 150% x rated load every 5 min
	Operating efficiency	Higher than 98%
	Fundamental power factor	Higher than 0.95 (full load at rated values)
Regenerative power supply module	Input voltage	4: 380–415 VAC; 7: 525–690 VAC; -10% to +10% (-15%, < 1 min)
	Input frequency range	47–63 Hz
	Output voltage	4: 540–590 VDC; 7: 740–975 VDC
	Overload capacity	Light overload: Continuous operation of 1 min allowed for 110% x rated load every 5 min; Heavy overload: Continuous operation of 1 min allowed for 150% x rated load every 5 min
	Operating efficiency	Higher than 98%
	Fundamental power factor	Higher than 0.95 (full load at rated values)
Active power supply module	Input voltage	4: 380–415 VAC; 5: 380–500 VAC; 7: 525–690 VAC; -10% to +10% (-15%, < 1 min)
	Input frequency range	47–63 Hz
	Output voltage	4: 540–720 VDC; 5: 570–750 VDC; 7: 740–975 VDC
	Overload capacity	Light overload: Continuous operation of 1 min allowed for 110% x rated load every 5 min; Heavy overload: Continuous operation of 1 min allowed for 150% x rated load every 5 min
	Operating efficiency	Higher than 97%
	Fundamental power factor	Higher than 0.99 (full load at rated values)
	Input harmonic current	THDI < 5% (rated power); THDU < 5% (Rzc > 20)
Drive module/ Single-drive	Input voltage	Multi-drive: 4: 540–720 VDC; 5: 540–750 VDC; 7: 740–975 VDC Single-drive: 4: 380–480 VAC; 7: 525–690 VAC
	Output voltage	Multi-drive: 4: 0–415 VAC; 5: 0–500 VAC; 7: 0–690 VAC; Single-drive: 4: 0–480 VAC; 7: 0–690 VAC
	Output frequency	0–300 Hz (Contact Inovance for frequencies higher than 300 Hz.)
	Operating efficiency	Higher than 98%
	Motor control mode	V/f, SVC, FVC
	Speed regulation range	V/f: 1:50; SVC: 1:200; FVC: 1:1000
	Speed control precision	SVC: ±10%; Fs (slip rate); FVC: ±0.01%
	Torque response	Open-loop: 5 ms; closed-loop: 3 ms
	Torque control mode	Sensorless vector control; feedback vector control
	Starting torque	0.5 Hz/150% (SVC); 0 Hz/200% (FVC)
Overload capacity	Light overload: Continuous operation of 1 min allowed for 110% x rated load every 5 min; Heavy overload: Continuous operation of 1 min allowed for 150% x rated load every 5 min	

Item	Description	
DCDC	Voltage on high voltage side	4: 540–720 V; 5: 540–850 V; 7: 740–1050 V
	Voltage on the low voltage side	4: 24–670 V; 5: 24–800 V; 7: 24–1000 V
	Voltage accuracy	Low-voltage side ≤ 0.1% Fs; High-voltage side ≤ 1% Fs
	Current accuracy	≤ 1% Fs
	Response time	≤ 3 ms (response time for increasing from 10% to 90% of rated current)
	Switchover time	≤ 6 ms (response time for changing from +90% to -90% of rated current)
	Overall efficiency	≥ 97%
	Overload capacity	Quick overload: 200% I _{fast} 10s overload for every 60s Heavy-overload: a minute of operation at 150% of rated current (150%I _r) allowed every 5 minutes
Connection	Analog input	Two AIs: -10 V to +10 V or -20 mA to +20 mA (selected through jumper)
	Analog output	Two AOs: 0 V to 10 V or 0 mA to 20 mA (selected through jumper)
	Digital input	Seven DIs: NPN/PNP; "0" < 5; "1" > 15, Rin: 2 kΩ
	High-speed digital input	Two high-speed DIs: NPN/PNP; "0" < 5; "1" > 15; Rin: 2 kΩ 24 V logic level, input frequency < 100 kHz
	High-speed digital output	Two high-speed DOs: OC; max. input voltage: 30 VDC; 24 V logic level, output frequency < 100 kHz
	Relay output	Three relay outputs; NO or NC output; 250 VAC/30 VDC, 2 A
	Intelligent operating panel or PC	Interface mode: Dual-RJ45 interface; physical layer: EIA-485; master-slave mode; max. communication rate: 4 Mbps
Ambient condition	Safety function	Safe torque off (optional)
	Inolink communication	Physical layer: EIA-485; max. communication rate: 5 Mbps
	Ambient temperature	-10°C to +40°C (non-frosting); derating required for temperatures between 40°C and 50°C
	Ambient humidity	5% to 95% (without condensation)
Mechanical data	Mounting altitude	Derating is not required for altitudes not higher than 1000 m. For altitudes higher than 1000 m, derate 1% for every additional 100 m. The maximum altitude is 4000 m. An isolation transformer is needed on the input side for altitudes higher than 2000 m.
	Vibration resistance	Compliant with Class 3M4 in GB/T4798.3
	IP rating	Module: IP00; Cabinet: IP21 IP23 and IP43 are optional.
	Safety performance	Compliant with EN 61800-5-1
Cooling mode	Cooling mode	AF (forced air cooling) compliant with EN 60146

Structure and Features of MD880 Multi-drive System



Note: We can provide well-assembled cabinets or standard power units as needed.

Topology of MD880 Multi-Drive System

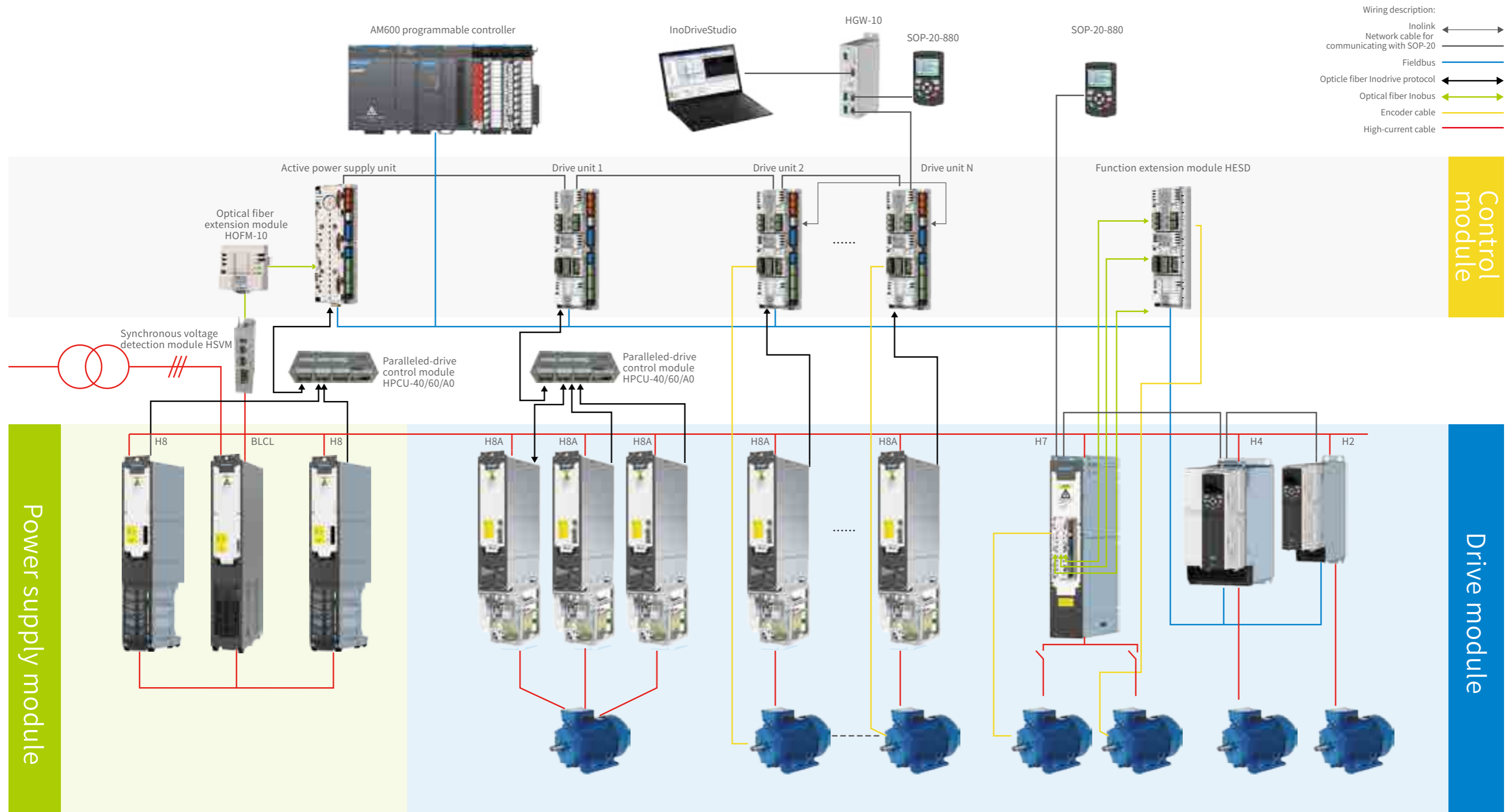

Centralized Monitoring/Remote Service Network

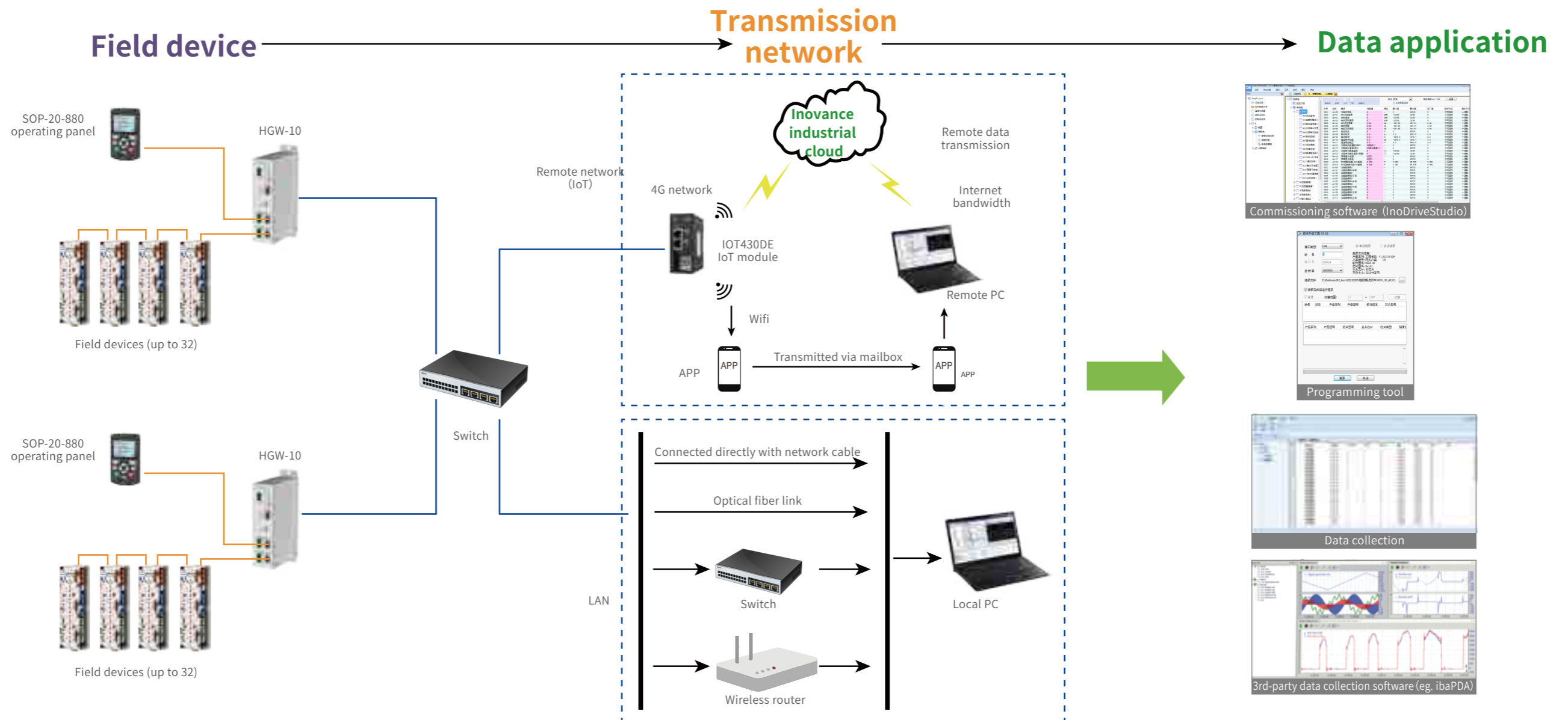

Graphical commissioning interface

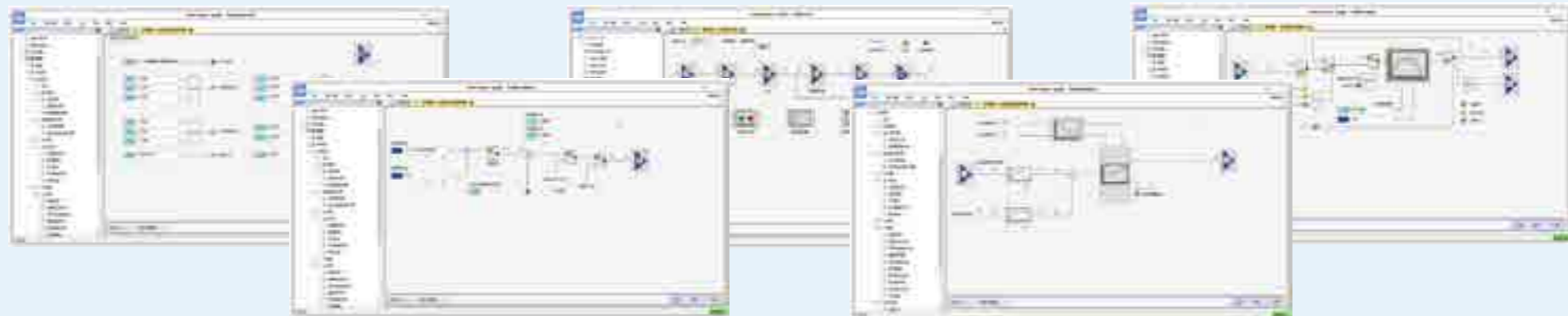

Technical Data of MD880 Series Products

Light-overload curve

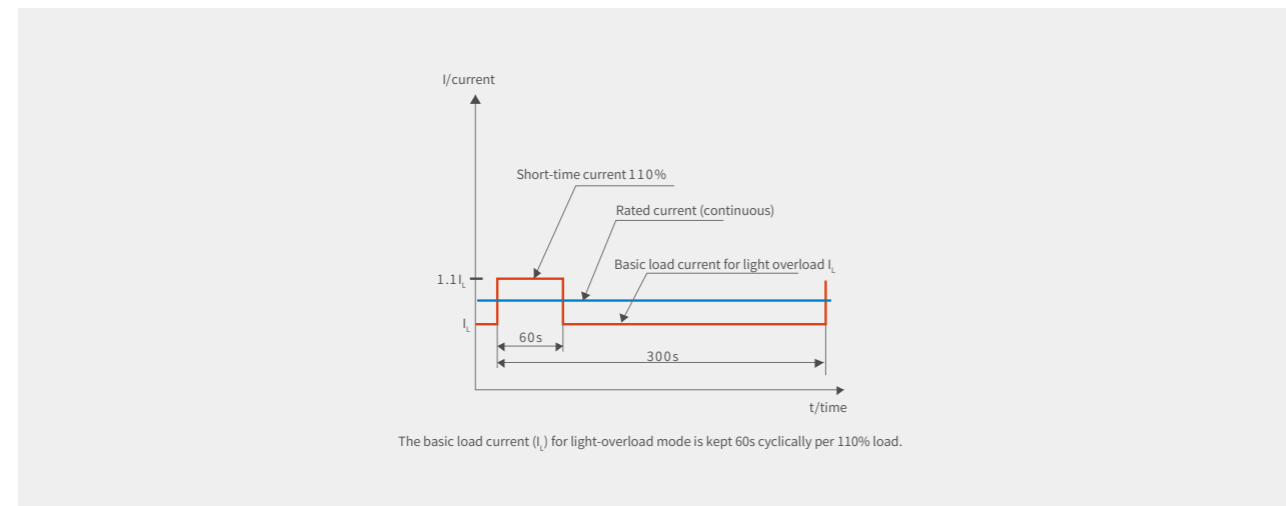

Heavy-overload curve

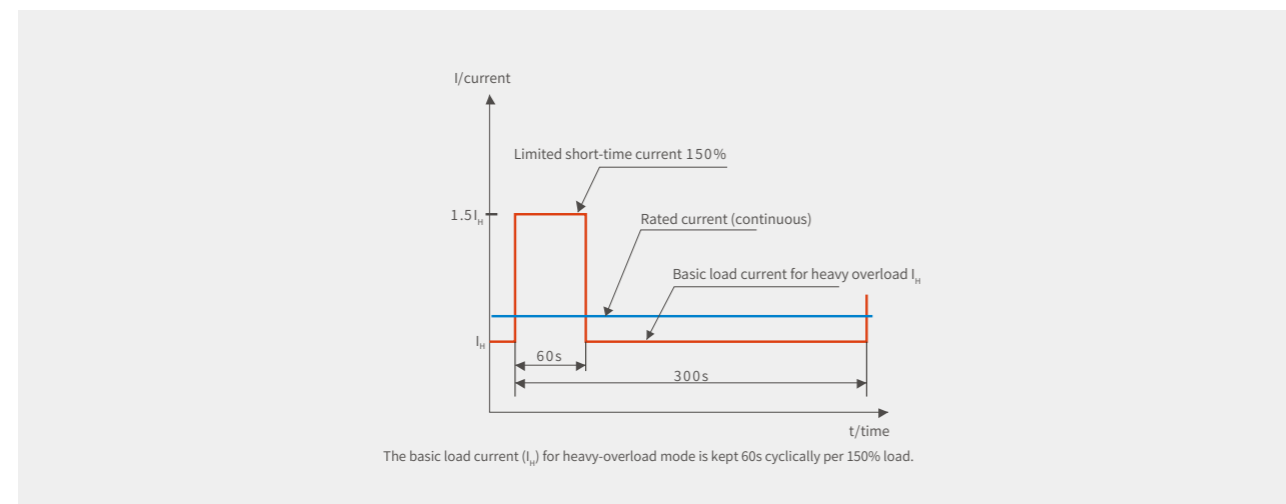

DCDC quick overload curve

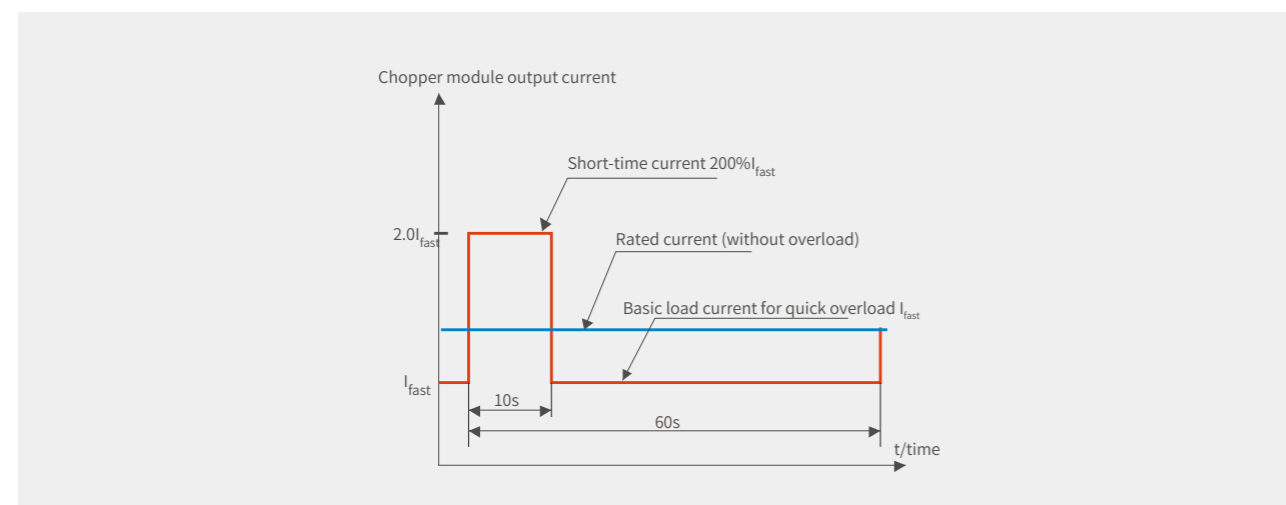

Technical data of MD880 Series Multi-drive Products

MD880LC-01S series water-cooled single-drive products

$U_n = 690\text{ V (525-690 V); } \pm 10\% (-15\%, < 1\text{ min})$ at 690 V rated power

Model MD880LC-01S...	Normal Duty Without Overload		Ligh-Overload Application		Heavy-Overload Application		Power Loss $c/a/T^{-1}$ (kW)	Outline Dimensions (W x D x H)
	I_N A(AC)	P_N kW(DC)	I_{Ld} A(DC)	P_{Ld} kW(DC)	I_{Hd} A(DC)	P_{Hd} kW(DC)		
0340-7 ^[1]	340	315	326	315	272	250	5.7/0.3/6.0	230 x 456 x 720
0530-7	530	500	509	500	424	400	9.0/0.5/9.5	

※[1]: This model is customized. Contact Inovance for details.

MD880LC-20M series water-cooled diode power supply module

$U_n = 690\text{ V (525-690 V), } \pm 10\% (-15\%, < 1\text{ min})$ at 690 V rated power

Model MD880LC-20M...	Normal Duty Without Overload				Ligh-Overload Application		Heavy-Overload Application		Rated Power Loss (kW)	Frame Size
	I_N A(AC)	I_N A(DC)	S_N kVA	P_N kW(DC)	I_{Ld} A(DC)	P_{Ld} kW(DC)	I_{Hd} A(DC)	P_{Hd} kW(DC)		
2000-7	2000	2441	2390	2273	2343	2182	1952	1819	11	D3D
3720-7	3720	4540	4446	4229	4358	4059	3632	3383	21	2 x D3D

MD880LC-40M series water-cooled AFE (Active Front End)

$U_n = 690\text{ V (525-690 V), } \pm 10\% (-15\%, < 1\text{ min})$ at 690 V rated power

Model MD880LC-40M...	Normal Duty Without Overload				Ligh-Overload Application		Heavy-Overload Application		Power Loss $c/a/T^{-1}$ (kW)	Outline Dimensions (W x D x H)
	I_N A(AC)	I_N A(DC)	S_N kVA	P_N kW(DC)	I_{Ld} A(DC)	P_{Ld} kW(DC)	I_{Hd} A(DC)	P_{Hd} kW(DC)		
0530-7	530	606	633	627	582	602	485	502	8.0/0.5/8.5	230 x 456 x 720
0650-7	650	743	777	769	713	738	594	615	9.8/0.6/10.4	

MD880LC-50M series water-cooled drive module

$U_n = 690\text{ V (525-690 V), } \pm 10\% (-15\%, < 1\text{ min})$ at 690 V rated power

Model MD880LC-50M...	Normal Duty Without Overload		Ligh-Overload Application		Heavy-Overload Application		Power Loss $c/a/T^{-1}$ (kW)	Outline Dimensions (W x D x H)
	I_N A(DC)	P_N kW(DC)	I_{Ld} A(DC)	P_{Ld} kW(DC)	I_{Hd} A(DC)	P_{Hd} kW(DC)		
0340-7 ^[1]	340	315	326	315	272	250	5.7/0.3/6.0	230 x 456 x 720
0530-7	530	500	509	500	424	400	9.0/0.5/9.5	
0650-7	650	630	624	630	520	500	10.7/0.6/11.3	

※ Note: c = Power dissipated in the cooling liquid; a = power dissipated in the air; T = total power loss, excluding the power loss of the input reactor
[1]: This model is customized. Contact Inovance for details.

Technical data of MD880 Series Multi-drive Products

MD880-20 series basic power supply module

UN = 400 V (380–415 V), ±10% (-15%, < 1 min) at 400 V rated power											
Model MD880-20...	Normal Duty Without Overload					Ligh-Overload Application		Heavy-Overload Application		Power Loss (kW)	Frame Size
	I _N	I _N	I _{Max}	S _N	P _N	I _{Ld}	P _{Ld}	I _{Hd}	P _{Hd}		
	A(AC)	A(DC)	A(DC)	kVA	kW(DC)	A(DC)	kW(DC)	A(DC)	kW(DC)		
6 pulse waves											
0718-4	718	879	1142	497	475	844	456	659	356	3.52	T2
0982-4	982	1202	1562	680	649	1154	623	901	487	5.12	T2
1336-4	1336	1635	2126	926	883	1570	848	1226	662	7.04	2 x T2
1826-4	1826	2235	2905	1265	1207	2146	1159	1676	905	10.24	2 x T2
2739-4	2739	3352	4358	1898	1810	3218	1738	2514	1358	15.36	3 x T2
3651-4	3651	4469	5809	2529	2413	4290	2317	3351	1810	20.48	4 x T2
4564-4	4564	5586	7262	3162	3016	5363	2896	4190	2262	25.6	5 x T2
5477-4	5477	6704	8715	3794	3620	6435	3475	5028	2715	30.72	6 x T2
12 pulse waves											
1336-4	1336	1635	2126	926	883	1570	848	1226	662	7.04	2 x T2
1826-4	1826	2235	2905	1265	1207	2146	1159	1676	905	10.24	2 x T2
2674-4	2674	3273	4255	1853	1767	3142	1697	2455	1325	14.08	4 x T2
3651-4	3651	4469	5809	2529	2413	4290	2317	3351	1810	20.48	4 x T2
4008-4	4008	4906	6377	2777	2649	4709	2543	3679	1987	21.12	6 x T2
5477-4	5477	6704	8715	3794	3620	6435	3475	5028	2715	30.72	6 x T2
UN = 690 V (525–690 V), ±10% (-15%, < 1 min) at 690 V rated power											
Model MD880-20...	Normal Duty Without Overload					Ligh-Overload Application		Heavy-Overload Application		Power Loss (kW)	Frame Size
	I _N	I _N	I _{Max}	S _N	P _N	I _{Ld}	P _{Ld}	I _{Hd}	P _{Hd}		
	A(AC)	A(DC)	A(DC)	kVA	kW(DC)	A(DC)	kW(DC)	A(DC)	kW(DC)		
6 pulse waves											
0570-7	570	698	907	681	650	670	624	523	487	2.96	T2
0815-7	815	998	1297	974	929	958	892	748	697	4.32	T2
1061-7	1061	1299	1688	1268	1210	1247	1161	974	907	5.92	2 x T2
1515-7	1515	1854	2411	1811	1727	1780	1658	1391	1295	8.64	2 x T2
2273-7	2273	2782	3617	2716	2591	2671	2488	2087	1944	12.96	3 x T2
3031-7	3031	3710	4823	3622	3456	3561	3317	2782	2592	17.28	4 x T2
3788-7	3788	4636	6027	4527	4319	4451	4146	3477	3239	21.6	5 x T2
4546-7	4546	5564	7233	5433	5183	5341	4976	4173	3887	25.92	6 x T2
12 pulse waves											
1061-7	1061	1299	1688	1268	1210	1247	1161	974	907	5.92	2 x T2
1515-7	1515	1854	2411	1811	1727	1780	1658	1391	1295	8.64	2 x T2
2122-7	2122	2597	3376	2536	2419	2493	2323	1948	1814	11.84	4 x T2
3031-7	3031	3710	4823	3622	3456	3561	3317	2782	2592	17.28	4 x T2
4546-7	4546	5564	7233	5433	5183	5341	4976	4173	3887	25.92	6 x T2

※Note: Data in the preceding table are for reference only.

Technical data of MD880 Series Multi-drive Products

MD880-30 series regenerative power supply module

UN = 400 V (380–415 V), ±10% (-15%, < 1 min) at 400 V rated power											
Model MD880-30...	Normal Duty Without Overload					Ligh-Overload Application		Heavy-Overload Application		Power Loss (kW)	Frame Size
	I _N	I _N	I _{Max}	S _N	P _N	I _{Ld}	P _{Ld}	I _{Hd}	P _{Hd}		
	A(AC)	A(DC)	A(DC)	kVA	kW(DC)	A(DC)	kW(DC)	A(DC)	kW(DC)		
0640-4	640	783	1018	443	423	752	406	587	317	7.9	L+H8
0900-4	900	1102	1432	624	595	1057	571	826	446	12	L+H8
1190-4	1190	1457	1894	825	787	1399	755	1093	590	14.1	L+2 x H8
1674-4	1674	2049	2664	1160	1106	1967	1062	1537	830	22.4	L+2 x H8
2380-4	2380	2913	3787	1649	1573	2796	1510	2185	1180	28.2	2 x (L+2 x H8)
3348-4	3348	4098	5327	2319	2213	3934	2124	3073	1660	44.8	2 x (L+2 x H8)
5022-4	5022	6147	7991	3479	3319	5901	3186	4610	2489	67.2	3 x (L+2 x H8)
UN = 690 V (525–690 V), ±10% (-15%, < 1 min) at 690 V rated power											
Model MD880-30...	Normal Duty Without Overload					Ligh-Overload Application		Heavy-Overload Application		Power Loss (kW)	Frame Size
	I _N	I _N	I _{Max}	S _N	P _N	I _{Ld}	P _{Ld}	I _{Hd}	P _{Hd}		
	A(AC)	A(DC)	A(DC)	kVA	kW(DC)	A(DC)	kW(DC)	A(DC)	kW(DC)		
0600-7	0600	734	955	717	684	705	657	551	513	9.2	L+H8
0900-7	0900	1102	1432	1076	1026	1057	985	826	770	13.1	L+H8
1116-7	1116	1366	1776	1334	1272	1311	1221	1024	954	16.5	L+2 x H8
1674-7	1674	2049	2664	2001	1909	1967	1832	1537	1431	24.4	L+2 x H8
2232-7	2232	2732	3551	2667	2545	2623	2443	2049	1909	33	2 x (L+2 x H8)
3348-7	3348	4098	5327	4001	3817	3934	3664	3073	2863	48.8	2 x (L+2 x H8)
5022-7	5022	6147	7991	6002	5726	5901	5497	4610	4294	73.2	3 x (L+2 x H8)

※Note: Data in the preceding table are for reference only.

Technical data of MD880 Series Multi-drive Products

MD880-40 series active power supply module

UN = 400 V (380–415 V), ±10% (-15%, <1min) at 400 V rated power											
Model MD880-40...	Normal Duty Without Overload					Ligh-Overload Application		Heavy-Overload Application		Power Loss (kW)	Frame Size
	I _N	I _N	I _{Max}	S _N	P _N	I _{Ld}	P _{Ld}	I _{Hd}	P _{Hd}		
	A(AC)	A(DC)	A(DC)	kVA	kW(DC)	A(DC)	kW(DC)	A(DC)	kW(DC)		
0094-4	94	107	140	65	64	103	62	81	48	1.6	LCL+H3
0149-4	149	170	221	103	102	164	98	128	77	2.55	LCL+H4
0183-4	183	209	272	127	126	201	120	157	94	3.15	LCL+H4
0299-4	299	342	444	207	205	328	197	256	154	5.12	LCL+H6
0395-4	395	452	587	274	271	433	260	339	203	6.77	LCL+H7
0575-4	575	657	854	398	394	631	379	493	296	10.7	BLCL+H8
0810-4	810	926	1204	561	556	889	533	694	417	15.5	BLCL+H8
1092-4	1092	1248	1623	757	749	1198	719	936	562	20.3	BLCL+2 x H8
1539-4	1539	1759	2287	1066	1056	1689	1013	1319	792	29.5	BLCL+2 x H8
2185-4	2185	2498	3247	1514	1499	2398	1439	1873	1124	40.6	2 x (BLCL+2 x H8)
3078-4	3078	3519	4574	2132	2111	3378	2027	2639	1583	58.9	2 x (BLCL+2 x H8)
4617-4	4617	5278	6861	3199	3167	5067	3040	3958	2375	88.4	3 x (BLCL+2 x H8)

UN = 500 V (380–500 V), ±10% (-15%, < 1 min) at 500 rated power											
Model MD880-40...	Normal Duty Without Overload					Ligh-Overload Application		Heavy-Overload Application		Outline Dimensions	
	I _N	I _N	I _{Max}	S _N	P _N	I _{Ld}	P _{Ld}	I _{Hd}	P _{Hd}		
	A (AC)	A (DC)	A (DC)	kVA	kW	A(DC)	kW(DC)	A(DC)	kW(DC)		
0540-5	540	617	802	468	463	593	444	463	347	BLCL+H8	
0810-5	810	926	1204	701	694	889	667	694	521	BLCL+H8	
1026-5	1026	1172	1524	889	880	1127	844	879	659	BLCL+2H8	

UN = 690 V (525–690 V), ±10% (-15%, < 1 min) at 690 V rated power											
Model MD880-40...	Normal Duty Without Overload					Ligh-Overload Application		Heavy-Overload Application		Power Loss (kW)	Frame Size
	I _N	I _N	I _{Max}	S _N	P _N	I _{Ld}	P _{Ld}	I _{Hd}	P _{Hd}		
	A(AC)	A(DC)	A(DC)	kVA	kW(DC)	A(DC)	kW(DC)	A(DC)	kW(DC)		
0369-7	0369	422	548	441	437	405	419	316	327	12.4	BLCL+H8
0540-7	0540	617	802	645	639	593	613	463	479	16.5	BLCL+H8
0701-7	0701	801	1042	838	829	769	796	601	622	23.6	BLCL+2 x H8
1026-7	1026	1173	1525	1226	1214	1126	1165	880	910	31.4	BLCL+2 x H8
1402-7	1402	1603	2083	1676	1659	1539	1592	1202	1244	47.2	2 x (BLCL+2 x H8)
2052-7	2052	2346	3049	2452	2428	2252	2331	1759	1821	62.8	2 x (BLCL+2 x H8)
3078-7	3078	3519	4574	3678	3642	3378	3496	2639	2731	94.2	3 x (BLCL+2 x H8)
4104-7	4104	4691	6099	4905	4856	4504	4661	3519	3642	126	4 x (BLCL+2 x H8)
5130-7	5130	5864	7632	6131	6069	5630	5827	4398	4552	157	5 x (BLCL+2 x H8)

※Note: Data in the preceding table are for reference only.

Technical data of MD880 Series Multi-drive Products

MD880-50 series drive module

UN = 400 V (380–415 V), ±10% (-15%, < 1 min) at 400 V rated power									
Model MD880-50...	Normal Duty Without Overload			Ligh-Overload Application		Heavy-Overload Application		Power Loss (W)	Frame Size
	I _N	I _{Max}	P _N	I _{Ld}	P _{Ld}	I _{Hd}	P _{Hd}		
	A(AC)	A(AC)	kW(AC)	A(AC)	kW(AC)	A(AC)	kW(AC)		
0009-4-SG	9	11	3.7	9	3.7	5.1	2.2	100.0	H1
0013-4-SG	13	15.6	5.5	13	5.5	9	3.7	136.0	H1
0017-4-SG	17	21	7.5	17	7.5	13	5.5	168.0	H1
0023-4-SG	23	27	11	22	11	17	7.5	190.0	H1
0033-4-SG	33	40	15	32	15	25	11	290	H2
0038-4-SG	38	51	18.5	37	18.5	32	15	308	H2
0048-4-SG	48	59	22	45	22	37	18.5	401	H2
0060-4-SG	60	72	30	58	30	45	22	502	H3
0078-4-SG	78	96	37	75	37	60	30	592	H3
0094-4-SG	94	120	45	91	45	75	37	735	H3
0116-4-SG	116	146	55	112	55	91	45	762	H4
0149-4-SG	149	179	75	143	75	112	55	1150	H4
0183-4-SG	183	240	90	176	90	150	75	1468	H4
0245-4-SG	245	294	110	236	110	184	90	1758	H6
0299-4-SG	299	358	132	287	132	224	110	2104	H6
0349-4-SG	349	419	160	335	160	262	132	2587	H7
0395-4-SG	395	486	200	380	200	296	160	3203	H7
0516-4-SG-(N)	516	619	250	495	250	387	200	4921	H8 (H8A)
0639-4-SG-(N)	639	766	355	613	315	479	250	6701	H8 (H8A)
0757-4-SG-(N)	757	909	400	727	400	568	315	7960	H8 (H8A)
0900-4-SG-(N)	900	1080	500	864	450	675	355	10133	H8 (H8A)
1213-4-SG-(N)	1213	1456	630	1165	630	910	500	13402	2 x H8 (2 x H8A)
1439-4-SG-(N)	1439	1727	800	1381	800	1079	630	15920	2 x H8 (2 x H8A)
1710-4-SG-(N)	1710	2052	1000	1642	900	1283	710	20266	2 x H8 (2 x H8A)
2158-4-SG-(N)	2158	2590	1200	2072	1200	1619	900	23880	3 x H8 (3 x H8A)
2565-4-SG-(N)	2565	3078	1400	2072	1400	1924	1000	30399	3 x H8 (3 x H8A)
3420-4-SG-(N)	3420	4104	1800	3283	1800	2565	1400	40532	4 x H8 (4 x H8A)
4275-4-SG-(N)	4275	5130	2400	4104	2000	3206	1800	50665	5 x H8 (5 x H8A)
5130-4-SG-(N)	5130	6156	2800	4925	2400	3848	2000	60798	6 x H8 (6 x H8A)

UN = 500 V (380–500 V), ±10% (-15%, < 1 min) at 500 V rated power									
Model MD880-50...	Normal Duty Without Overload				Ligh-Overload Application		Heavy-Overload Application		Outline Dimensions
	I _N	I _N	I _{max}	P _N	I _{Ld}	P _{Ld}	I _{Ld}	P _{Ld}	
	A (AC)	A (DC)	A (DC)	kW(DC)	A(AC)	kW(AC)	A(AC)	kW(AC)	
0349-5-SG	349	386	454	250	335	200	262	160	H7
0590-5-SG-(N)	590	653	767	400	566	355	443	250	H8A
0810-5-SG-(N)	810	886	1053	560	778	500	608	400	H8A

※Note: Data in the preceding table are for reference only.

Technical data of MD880 Series Multi-drive Products

MD880-50 series drive module

UN: Three-phase 690 VAC (range: 525–690 VAC)									
Model MD880-50...	Rated Value			Light-Overload Application		Heavy-Overload Application		Power Loss (W)	Frame Size
	I _N	I _{Max}	P _N	I _{Ld}	P _{Ld}	I _{Hd}	P _{Hd}		
	A(AC)	A(AC)	kW(AC)	A(AC)	kW(AC)	A(AC)	kW(AC)		
0062-7-SG	62	74	55	60	55	46	45	798	H6
0082-7-SG	82	98	75	79	75	61	55	1163	H6
0099-7-SG	99	119	90	95	90	74	75	1321	H6
0125-7-SG	125	150	110	120	110	94	90	1494	H6
0144-7-SG	144	173	132	138	132	108	110	1788	H6
0192-7-SG	192	230	160	184	160	144	132	2436	H6
0217-7-SG	217	260	200	215	200	162	160	2724	H7
0270-7-SG	270	324	250	260	250	202	200	3342	H7
0340-7-SG-(N)	340	408	315	326	315	255	250	5109	H8(H8A)
0410-7-SG-(N)	410	492	400	394	355	308	315	6143	H8(H8A)
0530-7-SG-(N)	530	636	500	509	450	398	355	7912	H8(H8A)
0600-7-SG-(N)	600	720	560	576	560	450	400	9086	H8(H8A)
0650-7-SG-(N)	650	780	630	624	560	488	450	10080	H8(H8A)
0721-7-SG-(N)	721	865	710	692	630	541	560	11000	H8(H8A)
0779-7-SG-(N)	779	935	800	748	710	584	560	12286	2 x H8 (2 x H8A)
1007-7-SG-(N)	1007	1208	1000	967	900	755	710	15824	2 x H8 (2 x H8A)
1140-7-SG-(N)	1140	1368	1100	1094	1000	855	800	18172	2 x H8 (2 x H8A)
1235-7-SG-(N)	1235	1482	1200	1186	1100	926	900	20160	2 x H8 (2 x H8A)
1370-7-SG-(N)	1370	1644	1300	1315	1200	1027	1000	22000	2 x H8 (2 x H8A)
1510-7-SG-(N)	1510	1812	1400	1450	1400	1133	1100	23736	3 x H8 (3 x H8A)
1710-7-SG-(N)	1710	2052	1600	1642	1600	1283	1200	27258	3 x H8 (3 x H8A)
1853-7-SG-(N)	1853	2223	1800	1778	1700	1389	1300	30240	3 x H8 (3 x H8A)
2055-7-SG-(N)	2055	2466	2000	1973	1900	1541	1500	33000	3 x H8 (3 x H8A)
2280-7-SG-(N)	2280	2736	2000	2189	2000	1710	1600	36344	4 x H8 (4 x H8A)
2470-7-SG-(N)	2470	2964	2400	2371	2300	1853	1800	40320	4 x H8 (4 x H8A)
2740-7-SG-(N)	2740	3288	2700	2630	2600	2055	2000	44000	4 x H8 (4 x H8A)
3088-7-SG-(N)	3088	3705	3000	2964	2900	2316	2300	50400	5 x H8 (5 x H8A)
3425-7-SG-(N)	3425	4110	3400	3288	3200	2569	2500	55000	5 x H8 (5 x H8A)
3705-7-SG-(N)	3705	4446	3600	3557	3500	2779	2700	60480	6 x H8 (6 x H8A)
4110-7-SG-(N)	4110	4932	4000	3945	3900	3082	3000	66000	6 x H8 (6 x H8A)
4323-7-SG-(N)	4323	5187	4300	4150	4100	3242	3200	70560	7 x H8 (7 x H8A)
4795-7-SG-(N)	4795	5754	4700	4603	4500	3596	3500	77000	7 x H8 (7 x H8A)
4940-7-SG-(N)	4940	5928	4900	4742	4700	3705	3600	80640	8 x H8 (8 x H8A)
5480-7-SG-(N)	5480	6576	5400	5260	5200	4110	4000	88000	8 x H8 (8 x H8A)

※Note: Data in the preceding table are for reference only.

Technical data of MD880 Series Multi-drive Products

MD880-60 series three-phase braking module

Model MD880-60...	Resistance of Braking Unit (Single-Phase)		Braking Threshold U _{br}	Without Overload			Cyclic Overload (1 min/5 min)		
	Ω			V	I _{dc}	I _{rms}	P	I _{dc}	I _{rms}
	A(AC)	A(AC)	V	A(DC)	A(AC)	kW	A(DC)	A(AC)	kW
0500-4	R _{min}	1.7	653	781	310	500	999	351	640
	R _{max}	2.1		781	282	500	827	291	530
0750-4	R _{min}	1.2		1171	465	750	1499	527	960
	R _{max}	1.4		1171	424	750	1241	436	800
0870-7	R _{min}	3.0	1126	781	310	870	999	351	1110
	R _{max}	3.6		781	283	870	833	293	920
1300-7	R _{min}	2.0		1171	465	1300	1499	527	1660
	R _{max}	2.4		1171	425	1300	1249	439	1390

MD880-61M single-phase braking module

Model MD880-61...	Resistance of Braking Unit (Single-Phase)		Braking Threshold U _{br}	Without Overload		Cyclic Overload (1 min/5 min)		Quick Overload (10s/60s)	
	Ω			V	I _{rms}	P _{cont}	I _{rms}	P _{br}	I _{rms}
	A(AC)	A(AC)	V	A(AC)	kW	A(AC)	kW	A(AC)	kW
0400-7	R _{min}	2.72	1126	131	147	267	298	361	404

MD880-80 series DCDC

Model MD880-80...	Voltage			Rated Value		Quick Overload (10s/60s)			Heavy-Overload Application (1 min/5 min)		Power Loss (W)	Frame Size
	V _I	V _O	V _{O nom}	I _N	P _N	I _{fast}	I _{max}	P _{fast}	I _{Hd}	P _{Hd}		
	V(DC)	V(DC)	V(DC)	A(DC)	kW	A(DC)	A(DC)	kW	A(DC)	kW		
0100-4	540–720	24–670	500	100	50	75	150	38	85	43	592	H3+LC
0200-4	540–720	24–670	500	200	100	150	300	75	170	85	762	H4+LC
0300-4	540–720	24–670	500	300	150	225	450	113	255	128	1468	H4+LC
0400-4	540–720	24–670	500	400	200	300	600	150	340	170	2104	H6+LC
0500-4	540–720	24–670	500	500	250	375	750	188	425	213	2587	H7+LC
0600-4	540–720	24–670	500	600	300	450	900	225	510	255	3203	H7+LC
0800-4	540–720	24–670	500	800	400	600	1200	300	680	340	4921	H8A+LC
1000-4	540–720	24–670	500	1000	500	750	1500	375	850	425	6701	H8A+LC
0600-5	540–850	24–800	500	600	300	450	900	225	510	255	3203	H7+LC
0100-7	740–1050	24–1000	1000	100	100	75	150	75	85	85	1321	H6+LC
0200-7	740–1050	24–1000	1000	200	200	150	300	150	170	170	2436	H6+LC
0300-7	740–1050	24–1000	1000	300	300	225	450	225	255	255	5109	H8A+LC
0400-7	740–1050	24–1000	1000	400	400	300	600	300	340	340	6143	H8A+LC
0500-7	740–1050	24–1000	1000	500	500	375	750	375	425	425	7912	H8A+LC
0600-7	740–1050	24–1000	1000	600	600	450	900	450	510	510	9086	H8A+LC

Odering Guide for MD880 Multi-drive Products

MD880-20 series basic power supply module

Model MD880-20...	Frame Size	Ordering No.	Qty	Remark
0718-4	T2	1. MD880-20M-0718-4	1	Basic power supply module
		2. HCU-20	1	Basic power supply control module
		3. T2-quick-kit	1	T2 quick installation kit
0982-4	T2	1. MD880-20M-0982-4	1	Basic power supply module
		2. HCU-20	1	Basic power supply control module
		3. T2-quick-kit	1	T2 quick installation kit
1336-4	2 x T2	1. MD880-20M-0718-4	2	Basic power supply module
		2. HCU-20	1	Basic power supply control module
		3. HPCU-40	1	Paralleled-module control module
		4. T2-quick-kit	2	T2 quick installation kit
1826-4	2 x T2	1. MD880-20M-0982-4	2	Basic power supply module
		2. HCU-20	1	Basic power supply control module
		3. HPCU-40	1	Paralleled-module control module
		4. T2-quick-kit	2	T2 quick installation kit
2739-4	3 x T2	1. MD880-20M-0982-4	3	Basic power supply module
		2. HCU-20	1	Basic power supply control module
		3. HPCU-40	1	Paralleled-module control module
		4. T2-quick-kit	3	T2 quick installation kit
3651-4	4 x T2	1. MD880-20M-0982-4	4	Basic power supply module
		2. HCU-20	1	Basic power supply control module
		3. HPCU-40	1	Paralleled-module control module
		4. T2-quick-kit	4	T2 quick installation kit
4564-4	5 x T2	1. MD880-20M-0982-4	5	Basic power supply module
		2. HCU-20	1	Basic power supply control module
		3. HPCU-60	1	Paralleled-module control module
		4. T2-quick-kit	5	T2 quick installation kit
5477-4	6 x T2	1. MD880-20M-0982-4	6	Basic power supply module
		2. HCU-20	1	Basic power supply control module
		3. HPCU-60	1	Paralleled-module control module
		4. T2-quick-kit	6	T2 quick installation kit

Odering Guide for MD880 Multi-drive Products

MD880-20 series basic power supply module

Model MD880-20...	Frame Size	Ordering No.	Qty	Remark
0570-7	T2	1. MD880-20M-0570-7	1	Basic power supply module
		2. HCU-20	1	Basic power supply control module
		3. T2-quick-kit	1	T2 quick installation kit
0815-7	T2	1. MD880-20M-0815-7	1	Basic power supply module
		2. HCU-20	1	Basic power supply control module
		3. T2-quick-kit	1	T2 quick installation kit
1061-7	2 x T2	1. MD880-20M-0570-7	2	T2 quick installation kit
		2. HCU-20	1	Basic power supply control module
		3. HPCU-40	1	Paralleled-module control module
		4. T2-quick-kit	2	T2 quick installation kit
1515-7	2 x T2	1. MD880-20M-0815-7	2	Basic power supply module
		2. HCU-20	1	Basic power supply control module
		3. HPCU-40	1	Paralleled-module control module
		4. T2-quick-kit	2	T2 quick installation kit
2273-7	3 x T2	1. MD880-20M-0815-7	3	T2 quick installation kit
		2. HCU-20	1	Basic power supply control module
		3. HPCU-40	1	Paralleled-module control module
		4. T2-quick-kit	3	T2 quick installation kit
3031-7	4 x T2	1. MD880-20M-0815-7	4	Basic power supply module
		2. HCU-20	1	Basic power supply control module
		3. HPCU-40	1	Paralleled-module control module
		4. T2-quick-kit	4	T2 quick installation kit
3788-7	5 x T2	1. MD880-20M-0815-7	5	T2 quick installation kit
		2. HCU-20	1	Basic power supply control module
		3. HPCU-60	1	Paralleled-module control module
		4. T2-quick-kit	5	T2 quick installation kit
4546-7	6 x T2	1. MD880-20M-0815-7	6	Basic power supply module
		2. HCU-20	1	Basic power supply control module
		3. HPCU-60	1	Paralleled-module control module
		4. T2-quick-kit	6	T2 quick installation kit

Odering Guide for MD880 Multi-drive Products

MD880-30 series regenerative power supply module

Model MD880-30...	Frame Size	Ordering No.	Qty	Remark
0640-4	L+H8	1. MD880-30K-0640-4	1	Regenerative power supply frame units
		2. HCU-30	1	Regenerative power supply control module
		3. HOFM-10	1	Optical fiber extension module
		4. HSVM-10	1	Synchronous voltage detection module
0900-4	L+H8	1. MD880-30K-0900-4	1	Regenerative power supply frame units
		2. HCU-30	1	Regenerative power supply control module
		3. HOFM-10	1	Optical fiber extension module
		4. HSVM-10	1	Synchronous voltage detection module
1190-4	L+2 x H8	1. MD880-30K-1190-4	1	Regenerative power supply frame units
		2. HCU-30	1	Regenerative power supply control module
		3. HPCU-40	1	Paralleled-module extension module
		4. HOFM-10	1	Optical fiber extension module
		5. HSVM-10	1	Synchronous voltage detection module
1674-4	L+2 x H8	1. MD880-30K-1674-4	1	Regenerative power supply frame units
		2. HCU-30	1	Regenerative power supply control module
		3. HPCU-40	1	Paralleled-module extension module
		4. HOFM-10	1	Optical fiber extension module
		5. HSVM-10	1	Synchronous voltage detection module
2380-4	2 x (L+2 x H8)	1. MD880-30K-1190-4	2	Regenerative power supply frame units
		2. HCU-30	1	Regenerative power supply control module
		3. HPCU-40	1	Paralleled-module extension module
		4. HOFM-10	1	Optical fiber extension module
		5. HSVM-10	1	Synchronous voltage detection module
3348-4	2 x (L+2 x H8)	1. MD880-30K-1674-4	2	Regenerative power supply frame units
		2. HCU-30	1	Regenerative power supply control module
		3. HPCU-40	1	Paralleled-module extension module
		4. HOFM-10	1	Optical fiber extension module
		5. HSVM-10	1	Synchronous voltage detection module
5022-4	3 x (L+2 x H8)	1. MD880-30K-1674-4	3	Regenerative power supply frame units
		2. HCU-30	1	Regenerative power supply control module
		3. HPCU-60	1	Paralleled-module extension module
		4. HOFM-10	1	Optical fiber extension module
		5. HSVM-10	1	Synchronous voltage detection module

Odering Guide for MD880 Multi-drive Products

MD880-30 series regenerative power supply module

Model MD880-30...	Frame Size	Ordering No.	Qty	Remark
0600-7	L+H8	1. MD880-30K-0600-7	1	Regenerative power supply frame units
		2. HCU-30	1	Regenerative power supply control module
		3. HOFM-10	1	Optical fiber extension module
		4. HSVM-10	1	Synchronous voltage detection module
0900-7	L+H8	1. MD880-30K-0900-7	1	Regenerative power supply frame units
		2. HCU-30	1	Regenerative power supply control module
		3. HOFM-10	1	Optical fiber extension module
		4. HSVM-10	1	Synchronous voltage detection module
1116-7	L+2 x H8	1. MD880-30K-1116-7	1	Regenerative power supply frame units
		2. HCU-30	1	Regenerative power supply control module
		3. HPCU-40	1	Paralleled-module extension module
		4. HOFM-10	1	Optical fiber extension module
		5. HSVM-10	1	Synchronous voltage detection module
1674-7	L+2 x H8	1. MD880-30K-1674-7	1	Regenerative power supply frame units
		2. HCU-30	1	Regenerative power supply control module
		3. HPCU-40	1	Paralleled-module extension module
		4. HOFM-10	1	Optical fiber extension module
		5. HSVM-10	1	Synchronous voltage detection module
2232-7	2 x (L+2 x H8)	1. MD880-30K-1116-7	2	Regenerative power supply frame units
		2. HCU-30	1	Regenerative power supply control module
		3. HPCU-40	1	Paralleled-module extension module
		4. HOFM-10	1	Optical fiber extension module
		5. HSVM-10	1	Synchronous voltage detection module
3348-7	2 x (L+2 x H8)	1. MD880-30K-1674-7	2	Regenerative power supply frame units
		2. HCU-30	1	Regenerative power supply control module
		3. HPCU-40	1	Paralleled-module extension module
		4. HOFM-10	1	Optical fiber extension module
		5. HSVM-10	1	Synchronous voltage detection module
5022-7	3 x (L+2 x H8)	1. MD880-30K-1674-7	3	Regenerative power supply frame units
		2. HCU-30	1	Regenerative power supply control module
		3. HPCU-60	1	Paralleled-module extension module
		4. HOFM-10	1	Optical fiber extension module
		5. HSVM-10	1	Synchronous voltage detection module

Odering Guide for MD880 Multi-drive Products

MD880-40 series active power supply module

Model MD880-40...	Frame Size	Ordering No.	Qty	Remark
0094-4	LCL+H3	MD880-40D-0094-4	1	Active power supply units
0149-4	LCL+H4	MD880-40D-0149-4	1	Active power supply units
0183-4	LCL+H4	MD880-40D-0183-4	1	Active power supply units
0299-4	LCL+H6	MD880-40D-0299-4	1	Active power supply units
0395-4	LCL+H7	MD880-40D-0395-4	1	Active power supply units
0575-4	BLCL+H8	1. MD880-40K-0575-4	1	Active power supply frame units
		2. HCU-40	1	Active power supply control module
		3. HOFM-10	1	Optical fiber extension module
		4. HSVM-10	1	Synchronous voltage detection module
0810-4	BLCL+H8	1. MD880-40K-0810-4	1	Active power supply frame units
		2. HCU-40	1	Active power supply control module
		3. HOFM-10	1	Optical fiber extension module
		4. HSVM-10	1	Synchronous voltage detection module
1092-4	BLCL+2H8	1. MD880-40K-1092-4	1	Active power supply frame units
		2. HCU-40	1	Active power supply control module
		3. HPCU-40	1	Paralleled-module extension module
		4. HOFM-10	1	Optical fiber extension module
		5. HSVM-10	1	Synchronous voltage detection module
1539-4	BLCL+2H8	1. MD880-40K-1539-4	1	Active power supply frame units
		2. HCU-40	1	Active power supply control module
		3. HPCU-40	1	Paralleled-module extension module
		4. HOFM-10	1	Optical fiber extension module
		5. HSVM-10	1	Synchronous voltage detection module
2185-4	2 x (BLCL+2H8)	1. MD880-40K-1092-4	2	Active power supply frame units
		2. HCU-40	1	Active power supply control module
		3. HPCU-40	1	Paralleled-module extension module
		4. HOFM-10	1	Optical fiber extension module
		5. HSVM-10	1	Synchronous voltage detection module
3078-4	2 x (BLCL+2H8)	1. MD880-40K-1539-4	2	Active power supply frame units
		2. HCU-40	1	Active power supply control module
		3. HPCU-40	1	Paralleled-module extension module
		4. HOFM-10	1	Optical fiber extension module
		5. HSVM-10	1	Synchronous voltage detection module
4617-4	3 x (BLCL+2H8)	1. MD880-40K-1539-4	3	Active power supply frame units
		2. HCU-40	1	Active power supply control module
		3. HPCU-60	1	Paralleled-module extension module
		4. HOFM-10	1	Optical fiber extension module
		5. HSVM-10	1	Synchronous voltage detection module
0540-5	BLCL+H8	1. MD880-40K-0540-5	1	Active power supply frame units
		2. HCU-40	1	Active power supply control module
		3. HOFM-10	1	Optical fiber extension module
		4. HSVM-10	1	Synchronous voltage detection module

Model MD880-40...	Frame Size	Ordering No.	Qty	Remark
0810-5	BLCL+H8	1. MD880-40K-0810-5	1	Active power supply frame units
		2. HCU-40	1	Active power supply control module
		3. HOFM-10	1	Optical fiber extension module
		4. HSVM-10	1	Synchronous voltage detection module
1026-5	BLCL+2H8	1. MD880-40K-1026-5	1	Active power supply frame units
		2. HCU-40	1	Active power supply control module
		3. HOFM-10	1	Optical fiber extension module
		4. HSVM-10	1	Synchronous voltage detection module
0369-7	BLCL+H8	1. MD880-40K-0369-7	1	Active power supply frame units
		2. HCU-40	1	Active power supply control module
		3. HOFM-10	1	Optical fiber extension module
		4. HSVM-10	1	Synchronous voltage detection module
0540-7	BLCL+H8	1. MD880-40K-0540-7	1	Active power supply frame units
		2. HCU-40	1	Active power supply control module
		3. HOFM-10	1	Optical fiber extension module
		4. HSVM-10	1	Synchronous voltage detection module
0701-7	BLCL+2H8	1. MD880-40K-0701-7	1	Active power supply frame units
		2. HCU-40	1	Active power supply control module
		3. HPCU-40	1	Paralleled-module extension module
		4. HOFM-10	1	Optical fiber extension module
		5. HSVM-10	1	Synchronous voltage detection module
1026-7	BLCL+2H8	1. MD880-40K-1026-7	1	Active power supply frame units
		2. HCU-40	1	Active power supply control module
		3. HPCU-40	1	Paralleled-module extension module
		4. HOFM-10	1	Optical fiber extension module
		5. HSVM-10	1	Synchronous voltage detection module
1402-7	2 x (BLCL+2H8)	1. MD880-40K-0701-7	2	Active power supply frame units
		2. HCU-40	1	Active power supply control module
		3. HPCU-40	1	Paralleled-module extension module
		4. HOFM-10	1	Optical fiber extension module
		5. HSVM-10	1	Synchronous voltage detection module
2052-7	2 x (BLCL+2H8)	1. MD880-40K-1026-7	2	Active power supply frame units
		2. HCU-40	1	Active power supply control module
		3. HPCU-40	1	Paralleled-module extension module
		4. HOFM-10	1	Optical fiber extension module
		5. HSVM-10	1	Synchronous voltage detection module
3078-7	3 x (BLCL+2H8)	1. MD880-40K-1026-7	3	Active power supply frame units
		2. HCU-40	1	Active power supply control module
		3. HPCU-60	1	Paralleled-module extension module
		4. HOFM-10	1	Optical fiber extension module
		5. HSVM-10	1	Synchronous voltage detection module
4104-7	4 x (BLCL+2H8)	1. MD880-40K-1026-7	4	Active power supply frame units
		2. HCU-40	1	Active power supply control module
		3. HPCU-A0	1	Paralleled-module extension module
		4. HOFM-10	1	Optical fiber extension module
		5. HSVM-10	1	Synchronous voltage detection module
5130-7	5 x (BLCL+2H8)	1. MD880-40K-1026-7	5	Active power supply frame units
		2. HCU-40	1	Active power supply control module
		3. HPCU-A0	1	Paralleled-module extension module
		4. HOFM-10	1	Optical fiber extension module
		5. HSVM-10	1	Synchronous voltage detection module

Odering Guide for MD880 Multi-drive Products

MD880-50 series drive module

Model MD880-50...	Frame Size	Ordering No.	Qty	Remark
0009-4-SG	H1	1. MD880-50M-0009-4-SG	1	Drive module
0013-4-SG	H1	1. MD880-50M-0013-4-SG	1	Drive module
0017-4-SG	H1	1. MD880-50M-0017-4-SG	1	Drive module
0023-4-SG	H1	1. MD880-50M-0023-4-SG	1	Drive module
0033-4-SG	H2	1. MD880-50M-0033-4-SG	1	Drive module
0038-4-SG	H2	1. MD880-50M-0038-4-SG	1	Drive module
0048-4-SG	H2	1. MD880-50M-0048-4-SG	1	Drive module
0060-4-SG	H2	1. MD880-50M-0060-4-SG	1	Drive module
0078-4-SG	H3	1. MD880-50M-0078-4-SG	1	Drive module
0094-4-SG	H3	1. MD880-50M-0094-4-SG	1	Drive module
0116-4-SG	H4	1. MD880-50M-0116-4-SG	1	Drive module
0149-4-SG	H4	1. MD880-50M-0149-4-SG	1	Drive module
0183-4-SG	H4	1. MD880-50M-0183-4-SG	1	Drive module
0245-4-SG	H6	1. MD880-50M-0245-4-SG	1	Drive module
0299-4-SG	H6	1. MD880-50M-0299-4-SG	1	Drive module
0349-4-SG	H7	1. MD880-50M-0349-4-SG	1	Drive module
0395-4-SG	H7	1. MD880-50M-0395-4-SG	1	Drive module
0516-4-SG	H8	1. MD880-50M-0516-4-SG	1	Drive module
		2. HCU-50S	1	Drive control module
		3. H8-quick-kit	1	H8 quick installation kit
0639-4-SG	H8	1. MD880-50M-0639-4-SG	1	Drive module
		2. HCU-50S	1	Drive control module
		3. H8-quick-kit	1	H8 quick installation kit
0757-4-SG	H8	1. MD880-50M-0757-4-SG	1	Drive module
		2. HCU-50S	1	Drive control module
		3. H8-quick-kit	1	H8 quick installation kit
0900-4-SG	H8	1. MD880-50M-0900-4-SG	1	Drive module
		2. HCU-50S	1	Drive control module
		3. H8-quick-kit	1	H8 quick installation kit
1213-4-SG	2 x H8	1. MD880-50M-0639-4-SG	2	Drive module
		2. HCU-50S	1	Drive control module
		3. HPCU-40	1	Paralleled-module control module
		4. H8-quick-kit	2	H8 quick installation kit

Odering Guide for MD880 Multi-drive Products

MD880-50 series drive module

Model MD880-50...	Frame Size	Ordering No.	Qty	Remark
1439-4-SG	2 x H8	1. MD880-50M-0757-4-SG	2	Drive module
		2. HCU-50S	1	Drive control module
		3. HPCU-40	1	Paralleled-module control module
		4. H8-quick-kit	2	H8 quick installation kit
1710-4-SG	2 x H8	1. MD880-50M-0900-4-SG	2	Drive module
		2. HCU-50S	1	Drive control module
		3. HPCU-40	1	Paralleled-module control module
		4. H8-quick-kit	2	H8 quick installation kit
2158-4-SG	3 x H8	1. MD880-50M-0757-4-SG	3	Drive module
		2. HCU-50S	1	Drive control module
		3. HPCU-40	1	Paralleled-module control module
		4. H8-quick-kit	3	H8 quick installation kit
2565-4-SG	3 x H8	1. MD880-50M-0900-4-SG	3	Drive module
		2. HCU-50S	1	Drive control module
		3. HPCU-40	1	Paralleled-module control module
		4. H8-quick-kit	3	H8 quick installation kit
3420-4-SG	4 x H8	1. MD880-50M-0900-4-SG	4	Drive module
		2. HCU-50S	1	Drive control module
		3. HPCU-40	1	Paralleled-module control module
		4. H8-quick-kit	4	H8 quick installation kit
4275-4-SG	5 x H8	1. MD880-50M-0900-4-SG	5	Drive module
		2. HCU-50S	1	Drive control module
		3. HPCU-60	1	Paralleled-module control module
		4. H8-quick-kit	5	H8 quick installation kit
5130-4-SG	6 x H8	1. MD880-50M-0900-4-SG	6	Drive module
		2. HCU-50S	1	Drive control module
		3. HPCU-60	1	Paralleled-module control module
		4. H8-quick-kit	6	H8 quick installation kit

Odering Guide for MD880 Multi-drive Products

MD880-50 series drive module

Model MD880-50...	Frame Size	Ordering No.	Qty	Remark
0516-4-SG-N	H8A	1. MD880-50M-0516-4-SG-N	1	Drive module
		2. HCU-50S	1	Drive control module
		3. H8A-kit-(L)	1	H8A mounting base
0639-4-SG-N	H8A	1. MD880-50M-0639-4-SG-N	1	Drive module
		2. HCU-50S	1	Drive control module
		3. H8A-kit-(L)	1	H8A mounting base
0757-4-SG-N	H8A	1. MD880-50M-0757-4-SG-N	1	Drive module
		2. HCU-50S	1	Drive control module
		3. H8A-kit-(L)	1	H8A mounting base
0900-4-SG-N	H8A	1. MD880-50M-0900-4-SG-N	1	Drive module
		2. HCU-50S	1	Drive control module
		3. H8A-kit-(L)	1	H8A mounting base
1213-4-SG-N	2 x H8A	1. MD880-50M-0639-4-SG-N	2	Drive module
		2. HCU-50S	1	Drive control module
		3. HPCU-40	1	Paralleled-module control module
		4. H8A-kit-L	2	H8A mounting base
1439-4-SG-N	2 x H8A	1. MD880-50M-0757-4-SG-N	2	Drive module
		2. HCU-50S	1	Drive control module
		3. HPCU-40	1	Paralleled-module control module
		4. H8A-kit-L	2	H8A mounting base
1710-4-SG-N	2 x H8A	1. MD880-50M-0900-4-SG-N	2	Drive module
		2. HCU-50S	1	Drive control module
		3. HPCU-40	1	Paralleled-module control module
		4. H8A-kit-L	2	H8A mounting base
2158-4-SG-N	3 x H8A	1. MD880-50M-0757-4-SG-N	3	Drive module
		2. HCU-50S	1	Drive control module
		3. HPCU-40	1	Paralleled-module control module
		4. H8A-kit-L	3	H8A mounting base
2565-4-SG-N	3 x H8A	1. MD880-50M-0900-4-SG-N	3	Drive module
		2. HCU-50S	1	Drive control module
		3. HPCU-40	1	Paralleled-module control module
		4. H8A-kit-L	3	H8A mounting base

Model MD880-50...	Frame Size	Ordering No.	Qty	Remark
1439-4-SG-N	2 x H8A	1. MD880-50M-0757-4-SG-N	2	Drive module
		2. HCU-50S	1	Drive control module
		3. HPCU-40	1	Paralleled-module control module
		4. H8A-kit-L	2	H8A mounting base
1710-4-SG-N	2 x H8A	1. MD880-50M-0900-4-SG-N	2	Drive module
		2. HCU-50S	1	Drive control module
		3. HPCU-40	1	Paralleled-module control module
		4. H8A-kit-L	2	H8A mounting base
2158-4-SG-N	3 x H8A	1. MD880-50M-0757-4-SG-N	3	Drive module
		2. HCU-50S	1	Drive control module
		3. HPCU-40	1	Paralleled-module control module
		4. H8A-kit-L	3	H8A mounting base
2565-4-SG-N	3 x H8A	1. MD880-50M-0900-4-SG-N	3	Drive module
		2. HCU-50S	1	Drive control module
		3. HPCU-40	1	Paralleled-module control module
		4. H8A-kit-L	3	H8A mounting base
3420-4-SG-N	4 x H8A	1. MD880-50M-0900-4-SG-N	4	Drive module
		2. HCU-50S	1	Drive control module
		3. HPCU-40	1	Paralleled-module control module
		4. H8A-kit-L	4	H8A mounting base
4275-4-SG-N	5 x H8A	1. MD880-50M-0900-4-SG-N	5	Drive module
		2. HCU-50S	1	Drive control module
		3. HPCU-60	1	Paralleled-module control module
		4. H8A-kit-L	5	H8A mounting base
5130-4-SG-N	6 x H8A	1. MD880-50M-0900-4-SG-N	6	Drive module
		2. HCU-50S	1	Drive control module
		3. HPCU-60	1	Paralleled-module control module
		4. H8A-kit-L	6	H8A mounting base
0349-5-SG	H7	1. MD880-50M-0349-5	1	Drive module
0590-5-SG-N	H8A	1. MD880-50M-0590-5	1	Drive module
		2. HCU-50S	1	Drive control module
		3. H8A-kit- (L)	1	H8A mounting base
0810-5-SG-N	H8A	1. MD880-50M-0810-5	1	Drive module
		2. HCU-50S	1	Drive control module
		3. H8A-kit- (L)	1	H8A mounting base

Odering Guide for MD880 Multi-drive Products

MD880-50 series drive module

Model MD880-50...	Frame Size	Ordering No.	Qty	Remark
0062-7-SG	H6	1. MD880-50M-0062-7-SG	1	Drive module
0082-7-SG	H6	1. MD880-50M-0082-7-SG	1	Drive module
0099-7-SG	H6	1. MD880-50M-0099-7-SG	1	Drive module
0125-7-SG	H6	1. MD880-50M-0125-7-SG	1	Drive module
0144-7-SG	H6	1. MD880-50M-0144-7-SG	1	Drive module
0192-7-SG	H6	MD880-50M-0192-7-SG	1	Drive module
0217-7-SG	H7	1. MD880-50M-0217-7-SG	1	Drive module
0270-7-SG	H7	1. MD880-50M-0270-7-SG	1	Drive module
0340-7-SG	H8	1. MD880-50M-0340-7-SG	1	Drive module
		2. HCU-50S	1	Drive control module
		3. H8-quick-kit	1	H8 quick installation kit
0410-7-SG	H8	1. MD880-50M-0410-7-SG	1	Drive module
		2. HCU-50S	1	Drive control module
		3. H8-quick-kit	1	H8 quick installation kit
0530-7-SG	H8	1. MD880-50M-0530-7-SG	1	Drive module
		2. HCU-50S	1	Drive control module
		3. H8-quick-kit	1	H8 quick installation kit
0600-7-SG	H8	1. MD880-50M-0600-7-SG	1	Drive module
		2. HCU-50S	1	Drive control module
		3. H8-quick-kit	1	H8 quick installation kit
0650-7-SG	H8	1. MD880-50M-0650-7-SG	1	Drive module
		2. HCU-50S	1	Drive control module
		3. H8-quick-kit	1	H8 quick installation kit
0721-7-SG	H8	1. MD880-50M-0721-7-SG	1	Drive module
		2. HCU-50S	1	Drive control module
		3. H8-quick-kit	1	H8 quick installation kit
0779-7-SG	2 x H8	1. MD880-50M-0410-7-SG	2	Drive module
		2. HCU-50S	1	Drive control module
		3. HPCU-40	1	Paralleled-module control module
		4. H8-quick-kit	2	H8 quick installation kit
1007-7-SG	2 x H8	1. MD880-50M-0530-7-SG	2	Drive module
		2. HCU-50S	1	Drive control module
		3. HPCU-40	1	Paralleled-module control module
		4. H8-quick-kit	2	H8 quick installation kit
1140-7-SG	2 x H8	1. MD880-50M-0600-7-SG	2	Drive module
		2. HCU-50S	1	Drive control module
		3. HPCU-40	1	Paralleled-module control module
		4. H8-quick-kit	2	H8 quick installation kit
1235-7-SG	2 x H8	1. MD880-50M-0650-7-SG	2	Drive module
		2. HCU-50	1	Drive control module
		3. HPCU-40	1	Paralleled-module control module
		4. H8-quick-kit	2	H8 quick installation kit
1370-7-SG	2 x H8	1. MD880-50M-0721-7-SG	2	Drive module
		2. HCU-50S	1	Drive control module
		3. HPCU-40	1	Paralleled-module control module
		4. H8-quick-kit	2	H8 quick installation kit
1510-7-SG	3 x H8	1. MD880-50M-0530-7-SG	3	Drive module
		2. HCU-50S	1	Drive control module
		3. HPCU-40	1	Paralleled-module control module
		4. H8-quick-kit	3	H8 quick installation kit
1710-7-SG	3 x H8	1. MD880-50M-0600-7-SG	3	Drive module
		2. HCU-50S	1	Drive control module
		3. HPCU-40	1	Paralleled-module control module
		4. H8-quick-kit	3	H8 quick installation kit

※Note: Copper bars can be used as the adapter to connect power output cables in absense of H8 quick installation kit (option).

Odering Guide for MD880 Multi-drive Products

MD880-50 series drive module

Model MD880-50...	Frame Size	Ordering No.	Qty	Remark
1853-7-SG	3 x H8	1. MD880-50M-0650-7-SG	3	Drive module
		2. HCU-50S	1	Drive control module
		3. HPCU-40	1	Paralleled-module control module
		4. H8-quick-kit	3	H8 quick installation kit
2055-7-SG	3 x H8	1. MD880-50M-0721-7-SG	3	Drive module
		2. HCU-50S	1	Drive control module
		3. HPCU-40	1	Paralleled-module control module
		4. H8-quick-kit	3	H8 quick installation kit
2280-7-SG	4 x H8	1. MD880-50M-0600-7-SG	4	Drive module
		2. HCU-50S	1	Drive control module
		3. HPCU-40	1	Paralleled-module control module
		4. H8-quick-kit	4	H8 quick installation kit
2470-7-SG	4 x H8	1. MD880-50M-0650-7-SG	4	Drive module
		2. HCU-50S	1	Drive control module
		3. HPCU-40	1	Paralleled-module control module
		4. H8-quick-kit	4	H8 quick installation kit
2740-7-SG	4 x H8	1. MD880-50M-0721-7-SG	4	Drive module
		2. HCU-50S	1	Drive control module
		3. HPCU-40	1	Paralleled-module control module
		4. H8-quick-kit	4	H8 quick installation kit
3088-7-SG	5 x H8	1. MD880-50M-0650-7-SG	5	Drive module
		2. HCU-50S	1	Drive control module
		3. HPCU-60	1	Paralleled-module control module
		4. H8-quick-kit	5	H8 quick installation kit
3425-7-SG	5 x H8	1. MD880-50M-0721-7-SG	5	Drive module
		2. HCU-50S	1	Drive control module
		3. HPCU-60	1	Paralleled-module control module
		4. H8-quick-kit	5	H8 quick installation kit
3705-7-SG	6 x H8	1. MD880-50M-0650-7-SG	6	Drive module
		2. HCU-50S	1	Drive control module
		3. HPCU-60	1	Paralleled-module control module
		4. H8-quick-kit	6	H8 quick installation kit
4110-7-SG	6 x H8	1. MD880-50M-0721-7-SG	6	Drive module
		2. HCU-50S	1	Drive control module
		3. HPCU-60	1	Paralleled-module control module
		4. H8-quick-kit	6	H8 quick installation kit
4323-7-SG	7 x H8	1. MD880-50M-0650-7-SG	7	Drive module
		2. HCU-50S	1	Drive control module
		3. HPCU-A0	1	Paralleled-module control module
		4. H8-quick-kit	7	H8 quick installation kit
4795-7-SG	7 x H8	1. MD880-50M-0721-7-SG	7	Drive module
		2. HCU-50S	1	Drive control module
		3. HPCU-A0	1	Paralleled-module control module
		4. H8-quick-kit	7	H8 quick installation kit
4940-7-SG	8 x H8	1. MD880-50M-0650-7-SG	8	Drive module
		2. HCU-50S	1	Drive control module
		3. HPCU-A0	1	Paralleled-module control module
		4. H8-quick-kit	8	H8 quick installation kit
5480-7-SG	8 x H8	1. MD880-50M-0721-7-SG	8	Drive module
		2. HCU-50S	1	Drive control module
		3. HPCU-A0	1	Paralleled-module control module
		4. H8-quick-kit	8	H8 quick installation kit

※Note: Copper bars can be used as the adapter to connect power output cables in absense of H8 quick installation kit (option).

Odering Guide for MD880 Multi-drive Products

MD880-50 series drive module

Model MD880-50...	Frame Size	Ordering No.	Qty	Remark
0340-7-SG-N	H8A	1. MD880-50M-0340-7-SG-N	1	Drive module
		2. HCU-50S	1	Drive control module
		3. H8A-kit-(L)	1	H8A mounting base
0410-7-SG-N	H8A	1. MD880-50M-0410-7-SG-N	1	Drive module
		2. HCU-50S	1	Drive control module
		3. H8A-kit-(L)	1	H8A mounting base
0530-7-SG-N	H8A	1. MD880-50M-0530-7-SG-N	1	Drive module
		2. HCU-50S	1	Drive control module
		3. H8A-kit-(L)	1	H8A mounting base
0600-7-SG-N	H8A	1. MD880-50M-0600-7-SG-N	1	Drive module
		2. HCU-50S	1	Drive control module
		3. H8A-kit-(L)	1	H8A mounting base
0650-7-SG-N	H8A	1. MD880-50M-0650-7-SG-N	1	Drive module
		2. HCU-50S	1	Drive control module
		3. H8A-kit-(L)	1	H8A mounting base
0721-7-SG-N	H8A	1. MD880-50M-0721-7-SG-N	1	Drive module
		2. HCU-50S	1	Drive control module
		3. H8A-kit-(L)	1	H8A mounting base
0779-7-SG-N	2 x H8A	1. MD880-50M-0410-7-SG-N	2	Drive module
		2. HCU-50S	1	Drive control module
		3. HPCU-40	1	Paralleled-module control module
		4. H8A-kit-L	2	H8A mounting base
1007-7-SG-N	2 x H8A	1. MD880-50M-0530-7-SG-N	2	Drive module
		2. HCU-50S	1	Drive control module
		3. HPCU-40	1	Paralleled-module control module
		4. H8A-kit-L	2	H8A mounting base
1140-7-SG-N	2 x H8A	1. MD880-50M-0600-7-SG-N	2	Drive module
		2. HCU-50S	1	Drive control module
		3. HPCU-40	1	Paralleled-module control module
		4. H8A-kit-L	2	H8A mounting base
1235-7-SG-N	2 x H8A	1. MD880-50M-0650-7-SG-N	2	Drive module
		2. HCU-50S	1	Drive control module
		3. HPCU-40	1	Paralleled-module control module
		4. H8A-kit-L	2	H8A mounting base
1370-7-SG-N	2 x H8A	1. MD880-50M-0721-7-SG-N	2	Drive module
		2. HCU-50S	1	Drive control module
		3. HPCU-40	1	Paralleled-module control module
		4. H8A-kit-L	2	H8A mounting base
1510-7-SG-N	3 x H8A	1. MD880-50M-0530-7-SG-N	3	Drive module
		2. HCU-50S	1	Drive control module
		3. HPCU-40	1	Paralleled-module control module
		4. H8A-kit-L	3	H8A mounting base
1710-7-SG-N	3 x H8A	1. MD880-50M-0600-7-SG-N	3	Drive module
		2. HCU-50S	1	Drive control module
		3. HPCU-40	1	Paralleled-module control module
		4. H8A-kit-L	3	H8A mounting base

Odering Guide for MD880 Multi-drive Products

MD880-50 series drive module

Model MD880-50...	Frame Size	Ordering No.	Qty	Remark
1853-7-SG-N	3 x H8A	1. MD880-50M-0650-7-SG-N	3	Drive module
		2. HCU-50S	1	Drive control module
		3. HPCU-40	1	Paralleled-module control module
		4. H8A-kit-L	3	H8A mounting base
2055-7-SG-N	3 x H8A	1. MD880-50M-0721-7-SG-N	3	Drive module
		2. HCU-50S	1	Drive control module
		3. HPCU-40	1	Paralleled-module control module
		4. H8A-kit-L	3	H8A mounting base
2280-7-SG-N	4 x H8A	1. MD880-50M-0600-7-SG-N	4	Drive module
		2. HCU-50S	1	Drive control module
		3. HPCU-40	1	Paralleled-module control module
		4. H8A-kit-L	4	H8A mounting base
2470-7-SG-N	4 x H8A	1. MD880-50M-0650-7-SG-N	4	Drive module
		2. HCU-50S	1	Drive control module
		3. HPCU-40	1	Paralleled-module control module
		4. H8A-kit-L	4	H8A mounting base
2740-7-SG-N	4 x H8A	1. MD880-50M-0721-7-SG-N	4	Drive module
		2. HCU-50S	1	Drive control module
		3. HPCU-40	1	Paralleled-module control module
		4. H8A-kit-L	4	H8A mounting base
3088-7-SG-N	5 x H8A	1. MD880-50M-0650-7-SG-N	5	Drive module
		2. HCU-50S	1	Drive control module
		3. HPCU-60	1	Paralleled-module control module
		4. H8A-kit-L	5	H8A mounting base
3425-7-SG-N	5 x H8A	1. MD880-50M-0721-7-SG-N	5	Drive module
		2. HCU-50S	1	Drive control module
		3. HPCU-60	1	Paralleled-module control module
		4. H8A-kit-L	5	H8A mounting base
3705-7-SG-N	6 x H8A	1. MD880-50M-0650-7-SG-N	6	Drive module
		2. HCU-50S	1	Drive control module
		3. HPCU-60	1	Paralleled-module control module
		4. H8A-kit-L	6	H8A mounting base
4110-7-SG-N	6 x H8A	1. MD880-50M-0721-7-SG-N	6	Drive module
		2. HCU-50S	1	Drive control module
		3. HPCU-60	1	Paralleled-module control module
		4. H8A-kit-L	6	H8A mounting base
4323-7-SG-N	7 x H8A	1. MD880-50M-0650-7-SG-N	7	Drive module
		2. HCU-50S	1	Drive control module
		3. HPCU-A0	1	Paralleled-module control module
		4. H8A-kit-L	7	H8A mounting base
4795-7-SG-N	7 x H8A	1. MD880-50M-0721-7-SG-N	7	Drive module
		2. HCU-50S	1	Drive control module
		3. HPCU-A0	1	Paralleled-module control module
		4. H8A-kit-L	7	H8A mounting base
4940-7-SG-N	8 x H8A	1. MD880-50M-0650-7-SG-N	8	Drive module
		2. HCU-50S	1	Drive control module
		3. HPCU-A0	1	Paralleled-module control module
		4. H8A-kit-L	8	H8A mounting base
5480-7-SG-N	8 x H8A	1. MD880-50M-0721-7-SG-N	8	Drive module
		2. HCU-50S	1	Drive control module
		3. HPCU-A0	1	Paralleled-module control module
		4. H8A-kit-L	8	H8A mounting base

※Note: Copper bars can be used as the adapter to connect power output cables in the absense of H8 quick installation kit (option). H8A-kit does not carry the output reactor base. H8A-kit-L carries the output reactor base.

Odering Guide for MD880 Multi-drive Products

MD880-60 series three-phase braking module

Model MD880-60...	Frame Size	Ordering No.	Qty	Remark
0500-4	H8	1. MD880-60M-0500-4	1	Three-phase braking module
		2. HCU-60	1	Three-phase braking module
		3. H8-quick-kit	1	H8 quick installation kit
0750-4	H8	1. MD880-60M-0750-4	1	Three-phase braking module
		2. HCU-60	1	Three-phase braking module
		3. H8-quick-kit	1	H8 quick installation kit
0870-7	H8	1. MD880-60M-0870-7	1	Three-phase braking module
		2. HCU-60	1	Three-phase braking module
		3. H8-quick-kit	1	H8 quick installation kit
1300-7	H8	1. MD880-60M-1300-7	1	Three-phase braking module
		2. HCU-60	1	Three-phase braking module
		3. H8-quick-kit	1	H8 quick installation kit

MD880-61 series single-phase braking module

Model MD880-61...	Ordering No.	Qty	Remark
0400-7	1. MD880-61M-0400-7	1	Single-phase braking module

MD880-80 series DC chopper unit

Model MD880-80...	Frame Size	Ordering No.	Qty	Remark
0100-4	H3+LC	MD880-80D-0100-4	1	DCDC units
0200-4	H4+LC	MD880-80D-0200-4	1	DCDC units
0300-4	H4+LC	MD880-80D-0300-4	1	DCDC units
0400-4	H6+LC	MD880-80D-0400-4	1	DCDC units
0500-4	H7+LC	MD880-80D-0500-4	1	DCDC units
0600-4	H7+LC	MD880-80D-0600-4	1	DCDC units
0800-4	H8A+LC	MD880-80D-0800-4	1	DCDC units
1000-4	H8A+LC	MD880-80D-1000-4	1	DCDC units
0600-5	H7+LC	MD880-80D-0600-5	1	DCDC units
0100-7	H6+LC	MD880-80D-0100-7	1	DCDC units
0200-7	H6+LC	MD880-80D-0200-7	1	DCDC units
0300-7	H8A+LC	MD880-80D-0300-7	1	DCDC units
0400-7	H8A+LC	MD880-80D-0400-7	1	DCDC units
0500-7	H8A+LC	MD880-80D-0500-7	1	DCDC units
0600-7	H8A+LC	MD880-80D-0600-7	1	DCDC units