LOW VOLTAGE AC DRIVES

ABB general purpose drives

ACS580, 1 to 700 HP



Table of contents

- The all-compatible ACS580 series 4
- Easily take full control of your processes to comprehensively manage your plant 6
- Typical industries and applications 8
- Food and beverage domain expertise..... 10
- Food and beverage software package for ACS580 (+N8057) 10
- Cooling and refrigeration in food and beverage.....11
- Pumping in food and beverage..... 12
- Ventilation in agriculture: Livestock and poultry 13
- Complete offering, from wall-mounted drives to cabinet installations..... 14
- Common features throughout the ACS580 product family 16
- Standard ACS580 drives software with versatile features17
- Standard interface and extensions for plug-in connectivity..... 18
- How to select a drive 19
- EU Ecodesign Regulation..... 20
- Technical data 21
- Dimensions 22
- Ratings, types and voltages 26
- Control panel options and mounting kits 37
- Door mounting and daisy chaining.....38
- Higher enclosure class for cabinet-free installations even in harsh conditions40
- ACS580-07 cabinet-built drives 42
- Commissioning, programming and customization tools44
- Communication and connectivity.....46
- Safety options 48
- ABB Ability™ Digital Powertrain50
- EMC – electromagnetic compatibility..... 52
- Harmonic mitigation54
- For explosive atmospheres 56
- Cooling and fuses 58
- Circuit breakers 64
- ACS580 drives are compatible with the wide ABB product offering..... 66
- Choose the right motor for your application..... 67
- Synchronous reluctance motors 68
- Selection guide 69
- ABB Access 70
- Scan the QR code to access 24/7 self-services for ABB drives, motors and PLCs..... 70
- ABB Access 70
- Drivetune mobile application for wireless access 71
- ABB SmartGuide – ACS580 72
- Our service expertise, your advantage..... 74
- ABB Drives Life Cycle Management 76
- Ordering information..... 78

The all-compatible ACS580 series

Effortless process automation

The ACS580 is an all-compatible ABB general purpose drive, offered both wall-mount and cabinet-build drives. It turns complicated to simple and controls processes productively and efficiently.

One product, many applications

ACS580 drives include all the essential components for typical light industry applications, with a scalable offering from 1 to 700 HP. The drive is ready to control as many other variable and constant torque applications. The all-compatible drives family ensures that you will always find the best drive for your needs. These drives share a similar user interface and PC tools, making using and learning them fast and easy.

The drive controls a wide range of applications in different industries, and yet it requires very little setting up or commissioning.

Reliability and consistent high quality

ACS580 drives are designed for customers who value high quality and robustness in their applications. The product features, such as coated boards and compact UL (NEMA) Type 12 / IP55 and 4X enclosures, make the ACS580 suitable for harsh conditions. Additionally, all ACS580 drives are tested at maximum temperature and with nominal loads. The tests include performance and all protective functions.

Easier than ever before

ACS580 drives have all the essential features built-in reducing the commissioning and set-up time. The assistant control panel with intuitive user interface is standard in ACS580 drives. Users can also upgrade to an optional Bluetooth control panel for wireless commissioning and monitoring. Primary settings and application control macros ensure quick product setup.

Available worldwide

With offices in over 90 countries and a network of global technical partners, you can rely on ABB for technical assistance and local support worldwide

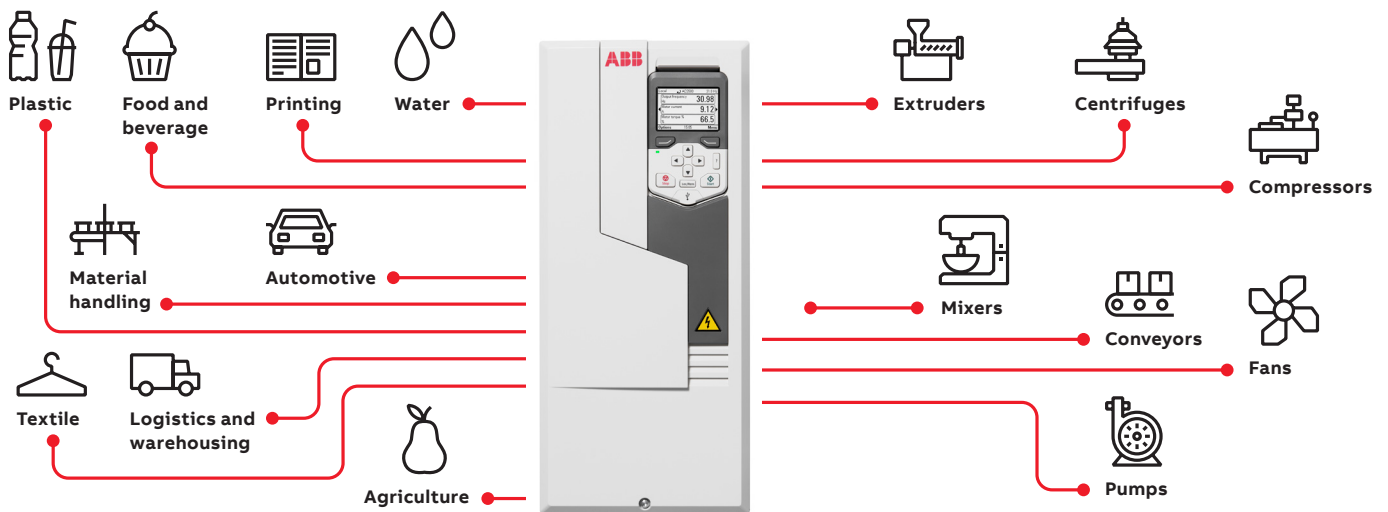



Easily take full control of your processes to comprehensively manage your plant

ACS580 drives are equipped with built-in features that simplify ordering and delivery, and reduce commissioning costs. Everything is provided in a single, compact and ready-to-use package for you to take full control of your processes.



Start-up and maintenance tool

Drive Composer PC tool for startup, configuration, monitoring and process tuning. The PC tool is connected to the drive's control panel via a USB interface.

Simple to select, install and use

Built-in features such as an EMC filter, choke, a Modbus RTU fieldbus interface and safe torque off functionality simplify drive selection, installation and use.



Simplicity at your fingertips as standard

The control panel's straightforward primary settings menu with assistants help you set up the drive quickly and effectively.

Boosting energy efficiency

Energy efficiency information is available in the energy optimizer feature to help you optimize your processes. The energy optimizer feature operates both in scalar and vector control modes, ensuring maximum torque per ampere and reducing energy drawn from the supply. You can follow the saved energy, CO₂ emissions or money, and see how fast the drive brings you a return on investment.

Scalable performance

The ACS580 is a perfect match not only for energy-aware applications, but also for applications where sophisticated speed and torque control are needed.



Effortless automation and productivity for your success



Communication with all major automation networks

Optional fieldbus adapters enable connectivity with all major industrial automation networks.



Reliable, integrated safety

The ATEX-certified thermistor protection module, Ex II (2) GD, CPTC-02 provides enhanced process safety and easy, simplified installation.



Adaptive programming

Adaptive programming is ideal for creating simple programs for various applications to further optimize the process control. It does not require expertise in programming.



Designed for maximum reliability

Design features such as coated circuit boards, minimized airflow through the control board section, and earth fault protection make the ACS580 a safe choice for multiple applications.



Remote monitoring

A built-in web server and stand-alone datalogger NETA-21 module enable worldwide and secure access to drives.

Typical industries and applications

ACS580 drives improve process performance, increase productivity, reduce external components and ensure machine and personnel safety



01



02



03



04



05



06



07



08











09

- 01 Food and beverage
- 02 Material handling
- 03 Printing

- 04 Rubber and plastics
- 05 Textile
- 06 Sawmill

- 07 Water handling
- 08 Agriculture
- 09 Automotive

Streamline your processes for profitable growth

Industry	Application	Customer benefits
Food and beverage 	Blowers, centrifuges, compressors, conveyors, fans, mills, pumps, separators, mixers, dryers, pelletizers	<ul style="list-style-type: none"> • Accurate control of the process increases the speed of food production while saving energy and improving work safety. Precise speed and torque control increases production uptime even when the load varies. • Increased starting torque with boost function allows the same drive series to be used in different applications in the manufacturing plant. • Safe Torque Off (SIL 3) function ensures machine and personnel safety. • The easy-to-use control panel with multiple languages and robust design reduce the time needed for maintenance. • UL Type 4X IP66 drives with NSF/ANSI food-safe certification allows drives to be close to the production process in clean, wet and dusty environments
Rubber and plastics 	Extruders, injection molding machines, pumps	<ul style="list-style-type: none"> • Smooth acceleration to prevent breaking the web of plastic film. • The scalable all-compatible platform allows easy process and component optimization with different drive types that share the same user interface and tools. • Wide range of supported fieldbus protocols for easy PLC integration.
Material handling 	Conveyors	<ul style="list-style-type: none"> • Accurate and precise speed and torque control increase production uptime even when the load varies. • Safe torque off (SIL 3) function ensures machine and personnel safety. • Minimized downtime with robust and reliable design. • Swinging choke technology to mitigate harmonics. • External +24 V supply to keep the communication up when the mains supply is disconnected.
Printing 	Compressors, presses, winders	<ul style="list-style-type: none"> • Smooth acceleration to prevent breaking the paper. • The robust design of the drive reduces mechanical stress on process line equipment, lowering maintenance costs and capital expenditure. • Precise speed and torque control of applications increases process uptime by optimizing motor control.
Textile 	Bleaching machines, compressors, conveyors, drum washers, extruders, fans, jet dyeing machines, pumps, stenter machines, stretchers, winders	<ul style="list-style-type: none"> • Precise speed or torque control for high stretching accuracy and better quality of the end product. • Adjustable torque limit to prevent damage to mechanical equipment. • Adjustable acceleration/deceleration ramps to improve pump control. • Real-time clock and timed functions for process optimization. • Increased productivity and faster payback times with multiple setups, allowing production of two different products. • Built-in counters for additional energy savings and preventive maintenance.
Sawmill 	Chippers, conveyors, feeders, dryers, pickers, drying kilns	<ul style="list-style-type: none"> • UL (NEMA) Type 12 / IP55 available up to 350 HP for dusty environments. • Cabinet-built drive IP54 up to 700 HP. • Safe torque off (SIL 3) function ensures machine and personnel safety. • External +24 V supply to keep the communications "alive" when the mains supply is turned off. • ATEX-certified thermistor protection module, Ex II (2) GD.
Water handling 	Compressors, pump stations	<ul style="list-style-type: none"> • Additional energy savings with energy optimizer function. • Adjustable acceleration/deceleration ramps to improve pump control. • Minimized downtime with robust and reliable design. • ABB's extensive product and service offering for comprehensive process optimization.
Agriculture 	Fans, irrigators, pumps, sorters	<ul style="list-style-type: none"> • UL (NEMA) Type 12 / IP55 available up to 350 HP and IP66/UL 4X up to 30 HP for dusty environments. • Wall-mounted power range up to 350 HP. • Drive modules and cabinet-built drives up to 700 HP.
Automotive 	Conveyors, fans, pumps	<ul style="list-style-type: none"> • Increased productivity and faster payback times with multiple setups. • Enhanced quality of end products with smooth control of the motor and process. • Safe torque off (SIL 3) function ensures machine and personnel safety. • Wide range of fieldbus networks supported, including PROFIBUS and PROFINET IO. • UL (NEMA) Type 12 / IP55 available up to 350 HP 460 V and high enclosure rating for dusty environments. • The robust design of the drive reduces mechanical stress on process line equipment, lowering maintenance costs and ensuring high production quality.

Food and beverage domain expertise

ABB has strong domain expertise in the food and beverage industry and its many subsegments. As part of ABB's general purpose drives family, the ACS580 is well suited to support a wide range of applications in the food and beverage subsegments below.

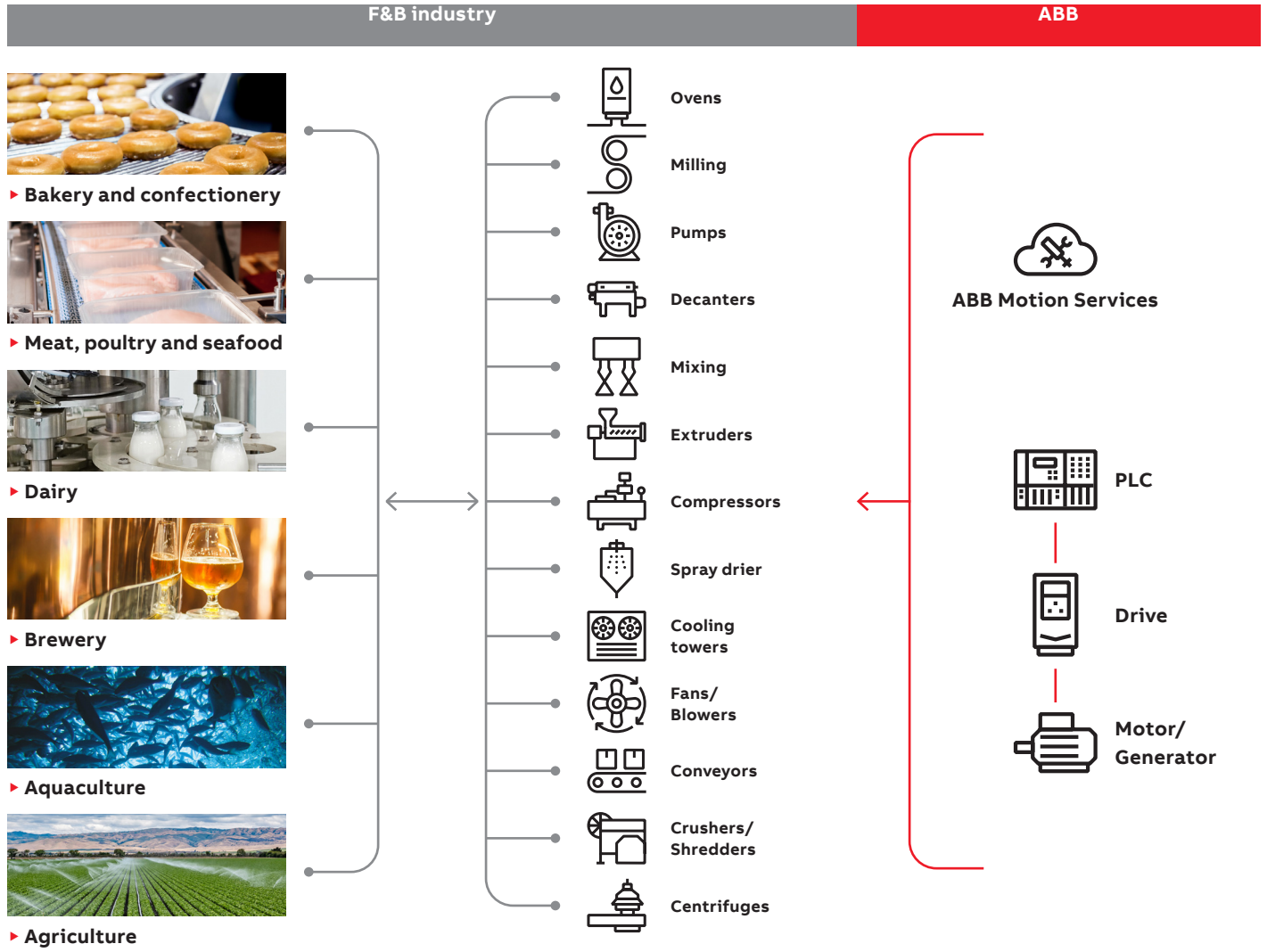

Food and beverage software package for ACS580 (+N8057)

To help our customers to be more effective, we offer a software package for the ACS580 which is dedicated to the food and beverage industry. The package consists of two different parts, which will improve your processes by utilizing segment-specific functions:

Food and beverage software package option for ACS580	
Plus code	Description
+N8057	Cooling compressor control ^{*)}
	Anti-cavitation ^{*)}

^{*)} More details on pages 11 and 12

Cooling and refrigeration in food and beverage

Food and beverage is the most significant segment for industrial refrigeration installations. From bakery to meat, dairy, fruit and vegetables, all require refrigeration across the entire cold chain which includes food process, cold storage, logistic centers and transportation.

Food and beverage software package for ACS580 (+N8057)

Cooling compressor control

Combining best-in-class drive technology with dedicated software for cooling compressors.

Cooling compressor macro

Sets typical parameter values for cooling compressor application and makes it easier to commission the drive.

Multi compressor control

Controlling more than one compressor with one drive, when needed, by changing all the relevant parameters and settings automatically.

Pressure to temperature conversion

Internal scaling is done based on refrigerant. System then automatically adjusts the cooling by using the PID.

Short cycle protection

Provides time delays in order to limit the number of starts to avoid damages from repetitive rapid-starting cycles.

Built-in intelligence



Reliable

Our high-quality package solution, based on our deep F&B domain expertise, includes reliable drives, motors and PLCs that help prevent unplanned downtime and other process risks.

Energy efficiency

Cooling systems are the biggest energy consumers in food processing plants. The use of VSDs in cooling compressors will provide average energy savings of 20-40% compared to running in DOL mode.

Easy to use

The user friendly interface and all compatible drive offering brings simplicity and time savings.

Flexible

By supporting all major Fieldbus protocols, wide I/O capacities and adaptive programming features, the ACS580 gives you freedom to design different kinds of control system topologies.

Pumping in food and beverage

A majority of the pump applications in food and beverage benefit from using a drive. The drive matches the pump-flow-rate with the actual demand, while saving energy and optimizing the production process.

The drive controls the pump-flow-rate by utilizing PID control and feedback from the sensor. This functionality controls the level, pressure, flow or temperature automatically.

Application example:

Level control of a beverage tank

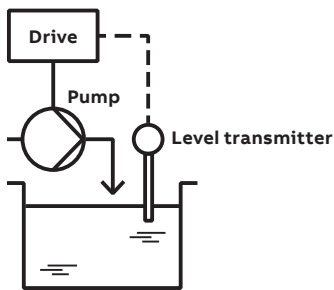

Food and beverage software package for ACS580 (+N8057)

Anti-cavitation

Cavitation is caused by local pressure changes in a liquid, creating vapor bubbles that can damage the pump and process when the vapor bubbles implode. In addition, cavitation can also cause unplanned downtime, production losses and even harm the end-product.

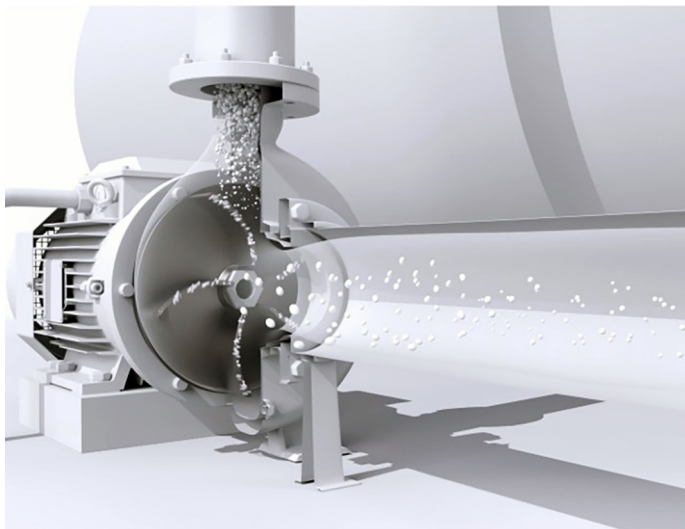

Quality in end-product

Anti-cavitation helps to avoid shock waves in the liquid. This may lead to poor product quality and lost revenues.

Lower total cost of ownership

Anti-cavitation eliminates the need for external sensors and reduces maintenance.

The Anti-cavitation feature enables reliable pump operations and increases productivity in the food and beverage industry.

Ventilation in agriculture: Livestock and poultry

ABB's agricultural expertise and the ACS580 deliver reliable ventilation conditions for your animals and increase overall productivity.

Robustness

- A conformal coating and UL (NEMA) Type 12 / IP55 and 4X options for harsh environment conditions
- Auto-derate option to avoid unwanted tripping of your applications like "oxygen supply fan"
- Built-in choke to reduce mains distortion

Animal welfare

- Optimal ventilation conditions ensure your animal's health and safety

Accessibility and flexibility

- Local/Remote control options
- Bluetooth panel option to connect your drive via your smart phone
- Long motor cable length

Cost savings

- Reducing fan speed via a drive, positively affects energy efficiency which lowers operating costs

Ammonia resistance for the complete drive (+C219)

Ammonia, which can be found in critical amounts in barns, has a corrosive effect on variable speed drives. The +C219 option, available with UL (NEMA) Type 4X / IP66 units, enables ammonia resistance not only for the control board, but also for the entire drive. This robust design prevents unplanned downtimes while providing an extended lifetime.

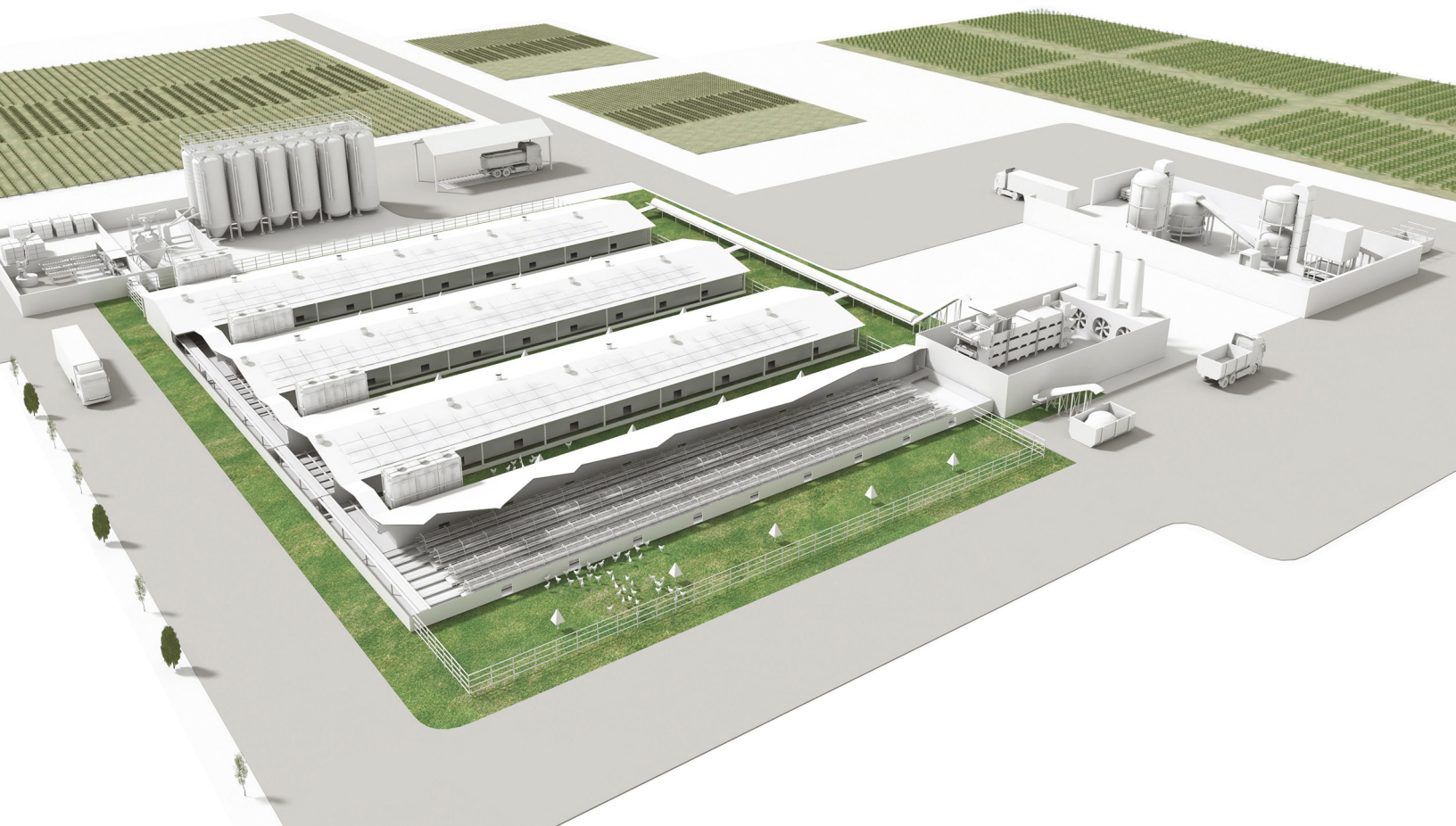

Complete offering, from wall-mounted drives to cabinet installations

Powerful, rugged and robust ACS580 drives ensure ease of use, scalability and quality. A wide power range and various mounting options and enclosure classes ensure you will find a drive for your installation and environment needs.

- 01 Wall-mounted ACS580 UL (NEMA) Type 1 / IP21 drive
- 02 Wall-mounted ACS580 UL Type 12 drive
- 03 Wall-mounted UL Type 4X drives, +B066
- 04 Flange-mounted ACS580 UL (NEMA) Type 1 / IP21 drive
- 05 ACS580 drive module with IP00
- 06 Cabinet-built ACS580 drive with IP42

Wall-mounted UL Type 1 drives, standard

Wall-mounted UL Type 1 drives are available in a power and voltage range from 1 to 350 HP and 3-phase 208, 230, 460 and 575 V. Side-by-side mounting, flange mounting and horizontal mounting are all available for wall-mounted ACS580 drives.



— 01

Wall-mounted UL Type 12 drives, +B056

The UL Type 12 drive is designed for applications exposed to dust, moisture, vibrations and other harsh environments. It is similar in size to the compact Type 1 drives, which provides significant savings in space, maintenance, engineering, and material costs, as well as in setup and commissioning time.



— 02

Wall-mounted UL Type 4X drives, +B066

Designed for extreme duty, the Type 4X drive can withstand unfriendly environments with ease. Available from 1 to 30 HP at all voltages, the drive is resistant to various weather conditions from the snows of winter to the heat of summer. Indoors, it is resistant to water spray, dirt and chemicals and is NSF/ANSI 169 certified for food splash zones.



— 03

Flange mounting option, +C135

The flange mounting option enables smaller cabinets to be used as the backside of the drive is installed outside of the cabinet. This mounting method improves the cooling system and decreases the investment in the cabinets. The flange mounting option is compatible with Type 1 or with Type 4X units. It maintains the protection class of UL Type 12 or 4X on the backside of the drive, while the front side of the drive is UL Type Open.

The option is also available as a loose item with an MRP code.



04

ACS580-0P Wall-mounted packaged drives, UL Type 1, 12 and 3R

These packaged drives included fuses and either an input disconnect switch or circuit breaker. This robust, rugged, and compact package enables mounting within line of site of equipment as well as an additional means for lockout tagout. They are available up to 200 HP at all voltage levels.

For outdoor applications, UL Type 3R packaged drive enclosures are constructed of sheet steel with a tough powder coat paint finish for corrosion resistance. A thermostatically controlled space heater and forced ventilated air cooling system are standard providing temperature control for a wide range of climates. They are available up to 60 HP at all voltage levels.



05

Cabinet-build drives, UL Type 12 (+B055)

The ACS580-07 cabinet-built single drives are designed for quick delivery, simple installation, and easy commissioning. A compact design makes handling the units easy and with all the essential features built-in. Commissioning and setup time is greatly reduced by leveraging the Primary Settings menus and assistants. Available from 200 to 700 HP at 460V.



06

Common features throughout the ACS580 product family



Standard ACS580 features

Choke and EMC

- Built-in choke with 5% equivalent impedance for harmonic mitigation
- Fulfills standard the EN61000-3-12 standard
- EMC C2 filter for R1-R9 allows safe installation in first environment

Scalar and vector control for process control

- Scalar control for effortless process control
- Vector control for accurate speed and torque control in demanding applications
- Support for induction, permanent magnet and synchronous reluctance motors (SynRM)

Extensive I/O connections

- The ACS580 features extensive I/O connections for flexible configuration in various applications
- Large color-coded terminals for easy commissioning and diagnostics

Assistant control panel and primary settings

- The ACS-AP-S assistant control panel speaks your language
- USB interface for PC and tool connection
- Help button for problem-solving and immediate diagnostics
- Bluetooth ACS-AP-W assistant control panel is standard on 580+B066 and optional on others

Integrated safe torque off (STO)

- Safe torque off for implementing safe machinery
- SIL 3, PL e

Brake control

- The brake chopper is built-in as standard for ACS580 frames up to R3. Braking control is integrated into ACS580 drives.
- Optional external brake chopper can be added for the frames R4-R9.

Performance

The ACS580 is suitable not only for variable torque applications but also for basic constant torque applications



Shared features of the ABB all-compatible drives portfolio

Same user interface

The drives follow the same operation logic and yet, there is an optimal drive from the smallest water pump to the biggest cement kiln, and everything in the between. When you have learned to use one drive, it is easy to use other drives in the portfolio.

Same PC tools

Free Drive Composer entry available at www.abb.com.

The same parameter structure makes the all-compatible platform easy to use.

Simple connectivity

- The ACS580 supports F-series fieldbus adapters used in the ABB all-compatible platform
- Mobile phone connectivity via the optional Bluetooth assistant control panel
- Fieldbus settings are made easy with the redesigned simple settings menu

Adaptive programming

- ACS580 firmware includes an easy-to-use and visual adaptive programming feature
- Adaptive programming can be used to add logical functions and conditions for process fine-tuning

Standard ACS580 drives software with versatile features

Save commissioning and learning time with the assistant control panel's clear and intuitive user interface and different assistants.

Improve the performance of the motor and process with sophisticated process control in scalar and vector control modes. The drive supports a wide range of motors, including induction and permanent magnet motors.

Analyze and optimize the application with the load profile log, which shows how the drive is operating.

Reduce motor noise with spreading the switching frequencies over a user-specified range.

Reduce costs with the built-in and standalone process PID. It makes the ACS580 a self-governing unit requiring only an external process measurement. No external logic input from the control room is needed.

Scale up and customize the drive to your application's requirements with flexible parameter pointers or adaptive programming.

Optimize energy efficiency with features that help you to save and manage energy. You can monitor the hourly, daily and cumulative energy consumption via kWh counters.

Analyze and resolve issues with the control panel's diagnostics menu. You can quickly analyze why the drive is performing as it is, whether running, stopped or running at the present speed.

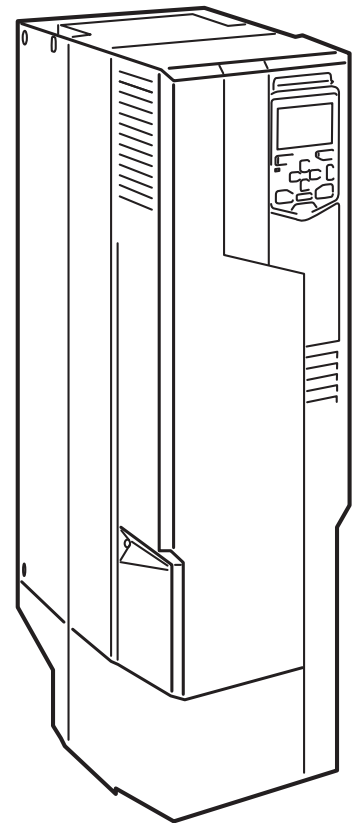

Standard interface and extensions for plug-in connectivity

ACS580 drives offer a wide range of standard interfaces. In addition, the drive has two option slots that can be used for extensions, including fieldbus adapters and input/output extension modules that allow an external +24 V supply with frame sizes R1 to R5. For frames R6-R11 external +24 V terminals are already integrated on the control board. For further information, please see the ACS580 user manual.

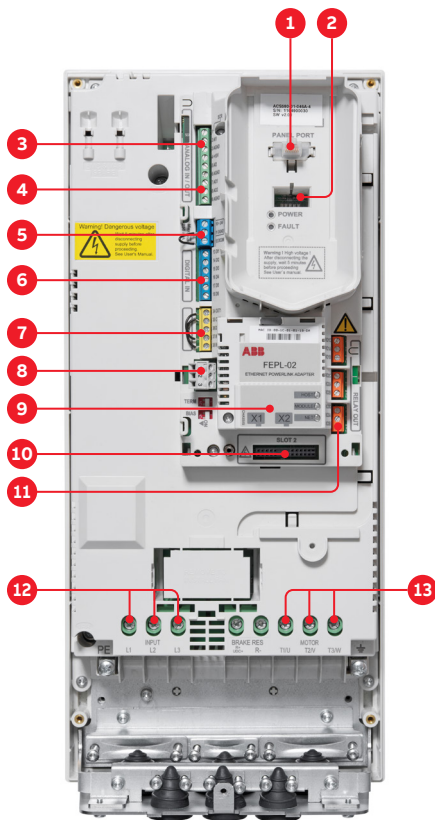

1. Panel port (PC tools, control panel)
2. ABB drive customizer port for programming the drive without mains
3. Analog inputs (2 × AI)
4. Analog outputs (2 × AO)
5. 24 V AC/DC output
6. Digital inputs (6 × DI)
7. Safe torque off (STO)
8. Embedded fieldbus
9. Communication options (fieldbuses)
10. I/O extensions
11. Relay outputs (3 × RO)
12. Mains connection
13. Motor connection

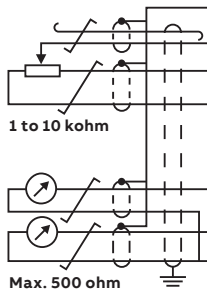

Default factory I/O connection diagram: Macro ABB standard

Terminal	Meaning	Default macro connections
X1 Reference voltage and analog inputs and outputs		
1	SCR	Signal cable shield (screen)
2	AI1	External frequency reference 1: 0 to 10 V
3	AGND	Analog input circuit common
4	+10 V	Output reference voltage 10 V DC
5	AI2	Not used
6	AGND	Analog input circuit common
7	AO1	Output frequency: 0 to 20 mA
8	AO2	Output current: 0 to 20 mA
9	AGND	Analog output circuit common

Terminal	Meaning	Default macro connections
X2 & X3 Aux. voltage output and programmable digital inputs		
10	+24 V	Auxiliary voltage output +24 V DC
11	DGND	Auxiliary voltage output common
12	DCOM	Digital input common for all DI
13	DI1	Start/Stop: Activate to start
14	DI2	Fwd/Rev: Activate to reverse rotation direction
15	DI3	Constant speed selection
16	DI4	Constant speed selection
17	DI5	Ramp pair selection: Activate to select second pair
18	DI6	Not used

Terminal	Meaning	Default macro connections
X6, X7, X8 Relay outputs		
19	RO1C	Ready
20	RO1A	250 V AC/30 V DC
21	RO1B	2 A
22	RO2C	Running
23	RO2A	250 V AC/30 V DC
24	RO2B	2 A
25	RO3C	Fault (-1)
26	RO3A	250 V AC/30 V DC
27	RO3B	2 A

Terminal	Meaning	Default macro connections
X5 EIA-485 Modbus RTU		
29	B+	Built-in Modbus RTU fieldbus interface
30	A-	
31	DGND	

Terminal	Meaning	Default macro connections
X4 Safe torque off		
34	OUT1	Safe torque off. Both circuits must be closed for the drive to start. The circuits are closed with jumper wires in the standard delivery.
35	OUT2	
36	SGND	
37	IN1	
38	IN2	

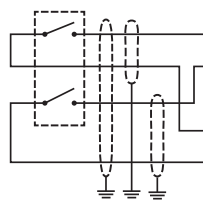

Terminal	Meaning	Default macro connections
X10*) 24 V AC/DC		
40	24 V	AC/DC-in. Ext. 24 V AC/DC input to power up the control unit when the main supply is disconnected
41	24 V	AC/DC+in.

*) The terminals 40-41 are integrated only in the frame sizes R6-R11. For the frame sizes R1-R5 I/O options (+L) are needed.

How to select a drive

The right drive is extremely easy to select. The following instructions show you how to order the right drive for your application.

Start by identifying your supply voltage.

Based on the supply voltage, follow either the right side or the middle section of the rating table. See pages 26-33.

Select your drive's order code from the rating table based on your motor's nominal power rating.

24 ABB GENERAL PURPOSE DRIVES, ACCESSORY CATALOG

Ratings, types and voltages

Multi-motor drive, ACS580-01 (3-phase supply voltage range 180-480 V)

Frame type	Frame size	Nominal ratings			Max. output current	S _{phases, U_n = 480 V}			Max. output current			
		P _n (kW)	I _n (A)	I _n (A)		P _n (kW)	I _n (A)	I _n (A)				
ACS580-01-00A7-4	01	0.75	1.6	2.5	0.75	1.8	0.55	3.2	2.1	1.5	0.75	2.8
	02	1.5	3.3	5.1	1.5	3.8	1.1	6.4	4.2	3.0	1.5	5.8
	03	3.0	6.6	10.2	3.0	7.6	2.2	12.8	8.4	6.0	3.0	11.6

Pages 26-33

Choose the motor power and current rating from the rating table on pages 26-33.

25 RATING, TYPES AND VOLTAGES

Multi-motor drive, ACS580-01 (3-phase supply voltage range 180-480 V)

Frame type	Frame size	Nominal ratings			Max. output current	S _{phases, U_n = 480 V}			Max. output current			
		P _n (kW)	I _n (A)	I _n (A)		P _n (kW)	I _n (A)	I _n (A)				
ACS580-01-00A7-4	01	0.75	1.6	2.5	0.75	1.8	0.55	3.2	2.1	1.5	0.75	2.8
	02	1.5	3.3	5.1	1.5	3.8	1.1	6.4	4.2	3.0	1.5	5.8
	03	3.0	6.6	10.2	3.0	7.6	2.2	12.8	8.4	6.0	3.0	11.6

Pages 26-33

Choose your options (on page 46) and add the option codes to the drive's order code.

Remember to use a "+" mark before each option code or order them as loose items. For more information, see page 78.

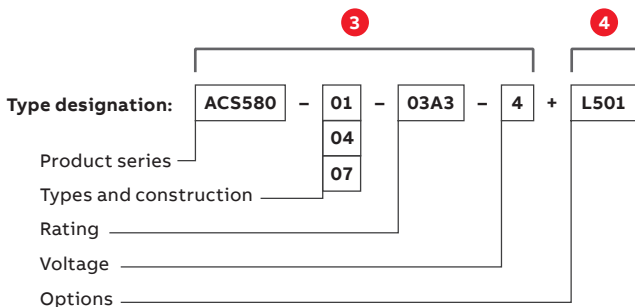

26 ABB GENERAL PURPOSE DRIVES, ACCESSORY CATALOG

Communication and connectivity Options

Fieldbus adapter module

Input/output extension modules

Part code	Part code	Fieldbus protocol	Adapter
01A1	01A00001	DeviceNet	01A00001
01A2	01A00002	PROFIBUS DP (DPV1/DPV2)	01A00002
01A3	01A00003	Canopen	01A00003
01A4	01A00004	Modbus RTU	01A00004
01A5	01A00005	ControlNet	01A00005
01A6	01A00006	EtherCAT	01A00006
01A7	01A00007	Profibus-DP	01A00007
01A8	01A00008	Two port Ethernet/IP	01A00008
01A9	01A00009	Two port Modbus/TCP	01A00009
01B0	01A00010	Two port Modbus/TCP	01A00010
01B1	01A00011	Safety AreaNet	01A00011
01B2	01A00012	Safety AreaNet	01A00012
01B3	01A00013	Safety AreaNet	01A00013
01B4	01A00014	Safety AreaNet	01A00014
01B5	01A00015	Safety AreaNet	01A00015
01B6	01A00016	Safety AreaNet	01A00016
01B7	01A00017	Safety AreaNet	01A00017
01B8	01A00018	Safety AreaNet	01A00018
01B9	01A00019	Safety AreaNet	01A00019
01C0	01A00020	Safety AreaNet	01A00020

Page 46

EU Ecodesign Regulation

The European Union has agreed upon the new, more demanding regulation (EU) 2019/1781, replacing regulation 640/2009. The new Ecodesign Regulation (EU) 2019/1781 sets the minimum efficiency levels not only for direct-on-line rated low voltage induction motors but now also for variable speed drives with a voltage up to 1000 V. The regulation will be implemented in two steps July 1, 2021 and July 1, 2023.



Variable speed drives

Step 1: July 1, 2021

IE2 efficiency level mandatory for AC drives

- Power range from 0.12 to 1000 kW.
- 3-phase drives with diode rectifier including ABB's micro, machinery, general purpose, industrial and industry-specific drives.
- Drive manufacturers must declare power losses in percentage of the rated apparent output power at 8 different operating points as well as standby losses. The international IE level is given at the nominal point. Drives fulfilling the requirements will be CE marked.
- All the covered ABB products fulfill the requirements.

Markings on the ABB AC drives

Unique identifier QR code to Ecodesign information



IE class and % loss of rated apparent power 50 Hz, 400 V

IE2 (90;100) 2,3 %

Unique QR codes are located on the rating plate and/or the front side of the drive.

Step 2: July 1, 2023

No changes for drives from July 1, 2021

For more information, see Ecodesign tool: <https://ecodesign.drivesmotors.abb.com/>

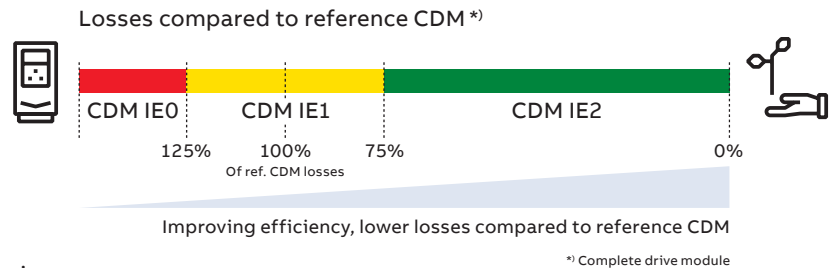

Excluded from the regulation:

- All drives without CE marking
- Following low voltage AC drives: regenerative drives, low-harmonic drives (THD < 10%), multiple AC-output drives and single-phase drives.
- Drive cabinets with already conformity assessed modules
- Medium voltage drives, DC drives and traction drives

Technical data

Mains connection	
Input voltage and output power range	1-phase, U1 240V +10%/-15% 3-phase, U1 200 to 240V, 380 to 480V, 575 to 600V +10%/-15% ACS580-01: 1 to 350HP ACS580-07: 200 to 700HP ACS580-0P: 1 to 200HP ACS580-0P (bypass): 1 to 350HP*** Auto-identification of supply voltage
Frequency	From 47 to 63 Hz
Power factor	cosφ = 0.98
Efficiency (at nominal power)	98%
Efficiency class (IEC 61800-9-2)	IE2
Motor connection	
Voltage	0 to U_1 , 3-phase
Frequency	0 to 500 Hz
Motor control	Scalar and vector control
Torque control	Torque step rise time: <10 ms with nominal torque Non-linearity: ± 5% with nominal torque
Speed control	Static accuracy: 20% of motor nominal slip Dynamic accuracy: 1% seconds with 100% torque step
Maximum recommended motor cable length	R1: 100 m R2: 200 m R3-R11: 300 m
Supported motor types	Asynchronous AC induction motors (IM) Permanent magnet motors (PMSM/IPM, PMSM/SPM) Synchronous reluctance motors (SynRM) Permanent magnet assisted synchronous reluctance motors (PMaSynRM, SynRM2, EC Titanium)
Product compliance¹	
CE UL 61800-5-1: 1st edition Low Voltage Directive 2014/34/EU, EN 61800-5-1: 2007 Machinery Directive 2006/42/EC, EN 61800-5-2: 2007 EMC Directive 2014/30/EU, EN 61800-3: 2004 + A1: 2012 RoHS directive 2011/65/EU Quality assurance system ISO 9001 and Environmental system ISO 14001 Waste electrical and electronic equipment directive (WEEE) 2002/96/EC RoHS directive 2011/65/EU cULus, CSA, EAC, RCM, KC TÜV Nord (safety functions) UKCA Ecodesign (EU) 2019/1781	
Harmonics compliance	
Built-in optimized DC choke as standard in AC580-01 meets the requirements of IEC 61000-3-12:2011.	
EMC according to EN 61800-3:2004 + A1:2012	
Frames R1 to R9 with built-in C2 category filter as standard Frames R10 and R11 with preconfigured built-in C3 category filter option	
Inputs and outputs (standard configuration)	
2 analog inputs	Selection of Current/Voltage input mode is user programmable.
Voltage signal	0 (2) to 10 V, R in >200 kΩ
Current signal	0 (4) to 20 mA, R in = 100 Ω
Potentiometer reference value	10 V ±1% max. 20 mA
2 analog outputs	AO1 is user programmable for current or voltage. AO2 current
Voltage signal	0 to 10 V, R load: >100 kΩ
Current signal	0 to 20 mA, R load: <500 Ω
Internal auxiliary voltage	24 V DC ±10%, max. 250 mA
6 digital inputs	12 to 24 V DC, 24 V AC, Connectivity of PTC sensors supported by a single digital input. PNP or NPN connection (5 DIs with NPN connection).
3 relay outputs	Maximum switching voltage 250 V AC/30 V DC Maximum continuous current 2 A rms

Supported thermistors	Any of the analog inputs, or digital input 6, are configurable for PTC with up to 6 sensors. Both analog outputs can be used to feed the PT100, PT1000, KTY83, KTY84 or Ni1000 sensors. For more detailed information please see the ACS580 hardware manual.
Environmental limits	
Ambient temperature	
Transport Storage	-40 to +70 °C -40 to +70 °C
Operation area	ACS580-01: -15 to +50 °C. No frost allowed R1 to R9 from +40 to +50 °C with derating ACS580-04: -15 to +55 °C. No frost allowed R10 to R11 from +40 to +55 °C with derating ACS580-07: 0 to +40 °C. No frost allowed R6 to R11 from +40 to +50 °C with derating
Cooling method	Air-cooled
Air-cooled	Dry clean air
Altitude	0 to 1,000 m Without derating 1,000 to 4,000 m With derating of 1%/100 m For more detailed information please see the ACS580 hardware manual
Relative humidity	5 to 95%, no condensation allowed
Degree of protection	ACS580-01: UL (NEMA) Type 1 / IP21 as standard UL (NEMA) Type 12 / IP55 as option (frames R1 to R9) UL (NEMA) Type 4X / IP66 as option (frames R1 to R3) ACS580-07: Cabinet-built frames R8 to R11 UL Type 12 (IP54) is North America standard ACS580-0P: UL (NEMA) Type 1 / IP21 as standard UL (NEMA) Type 12 / IP55 and UL Type 3R as options ACS580-0P (bypass): UL (NEMA) Type 1, 12, 3R
Functional safety	Safe torque off (STO according EN 61800-5-2) IEC 61508 ed2: SIL 3. IEC 61511: SIL 3. IEC 62061: SIL CL 3. EN ISO 13849-1: PL e
Contamination levels	No conductive dust allowed
Storage	IEC 60721-3-1. Class 1C2 (chemical gases). Class 1S2 (solid particles) ^{*)}
Operation	IEC 60721-3-3. Class 3C2 (chemical gases). Class 3S2 (solid particles) ^{*)}
Transportation	IEC 60721-3-2. Class 2C2 (chemical gases). Class 2S2 (solid particles) ^{*)}
External power supply	
Standard: ACS580-01 frames R6-R9, ACS580-07 all frames 1.5 A at 24 V AC/DC ±10%	
With option CMOD-01, -02: ACS580-01 frames R1-R5 1.04 A at 24 V AC/DC ±10%	
Communication	
Protocol as standard (EIA-485): Modbus RTU. Protocols available as option: EtherNet/IP, EtherNet POWERLINK, Modbus/TCP, EtherCAT, PROFINET IO, PROFISafe (for STO and SS1-t functions), CANopen, ControlNet, DeviceNet and Profibus DP.	
Protection functions	
Overvoltage controller Undervoltage controller Motor and motor cable earth-leakage monitoring Motor and motor cable short-circuit protection Motor over-temperature protection Output and input switch supervision Motor overload protection Phase-loss detection (both motor and supply) Under load supervision (belt loss detection) Overload supervision Stall protection Loss of control reference	

^{*)} C = Chemically active substances

S = Mechanically active substances

¹ US ratings 343A-2 and 396A-2 have not been verified to comply with CSA, CE or IEC directives or any standard other than UL 61800-5-1: 1st edition.

*** 3-phase, 208/230V, 460V, 575V Wye, 60 Hz

Dimensions

ACS580-01 UL (NEMA) Type 1 / IP21, wall-mounted

Frames	Height 1		Height 2		Width		Depth		Weight	
	(mm)	(in)	(mm)	(in)	(mm)	(in)	(mm)	(in)	(kg)	(lb)
R1	373	14.69	331	13.04	123	4.82	223	8.78	4.6	11
R2	473	18.62	432	17.02	123	4.86	229	9.00	6.6	15
R3	490	19.29	490	19.29	203	7.99	229	9.01	11.8	26
R4	636	25.04	636	25.04	203	7.99	257	10.13	19	42
R5	732	28.83	596	23.46	203	7.99	295	11.60	28.3	63
R6	727	28.60	548	21.57	252	9.92	369	14.53	42.4	94
R7	880	34.67	600	23.62	284	11.18	370	14.58	54	120
R8	965	38.01	680	26.77	300	11.81	393	15.47	69	153
R9	955	37.60	680	26.77	380	14.96	418	16.46	97	214

Height 1: Total height of the drive (front) with cable box

Height 2: Total height of the drive (back) without cable box

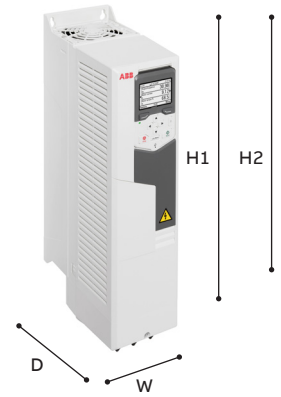

ACS580-01 UL (NEMA) Type 12 / IP55 (+B056), wall-mounted

Frames	Height 1		Height 2		Width		Depth		Weight	
	(mm)	(in)	(mm)	(in)	(mm)	(in)	(mm)	(in)	(kg)	(lb)
R1	403	15.86	452	17.78	129	5.06	233	9.17	4.8	11
R2	503	19.80	546	21.49	129	5.06	239	9.40	6.8	15
R3	490	19.29	532	20.93	206	8.11	237	9.32	13	29
R4	636	25.04	687	27.03	203	7.99	265	10.44	20	45
R5	732	28.83	813	32.01	203	7.99	320	12.59	29	64
R6	726	28.58	884	34.81	252	9.92	417	16.40	43	95
R7	880	34.66	1038	40.86	284	11.18	414	16.30	56	124
R8	965	37.99	1123	44.23	300	11.81	452	17.80	77	170
R9	955	37.60	1187	46.75	380	14.96	477	18.78	103	228

Height 1: Height of the drive from cable box to top of mounting flange

Height 2: Overall height of the drive including cable box and Type 12 hood

Note: Total height of the drive (back) without cable box is the same as Type 1

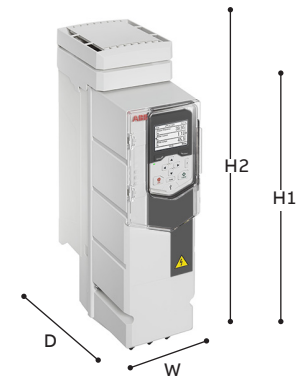

ACS580-01 flange mounting dimensions, with +C135 or a loose option kit for UL (NEMA) Type 1 / IP21

Frames	Height		Width		Depth - Front		Depth - Back		Weight	
	(mm)	(in)	(mm)	(in)	(mm)	(in)	(mm)	(in)	(kg)	(lb)
R1	461	18.15	206	8.12	133	5.22	109	4.28	4.6	10
R2	551	21.69	206	8.12	130	5.13	114	4.51	6.5	15
R3	613	24.13	290	11.42	118	4.65	116	4.58	11.8	26
R4	776	30.55	290	11.42	122	4.80	137	5.41	19	42
R5	776	30.55	290	11.42	126	4.97	171	6.73	28.3	62
R6	672	26.46	374	14.72	194	7.63	170	6.67	42.4	94
R7	722	28.43	406	15.98	195	7.67	169	6.65	54	119
R8	814	32.05	433	17.06	202	7.95	184	7.22	69	152
R9	804	31.65	502	19.76	204	8.03	209	8.21	97	214

Note: Hood for Type 12 requires additional height outside enclosure. See supplement.

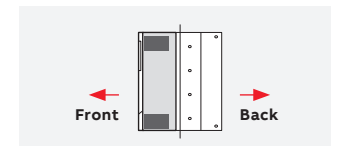

Dimensions



ACS580-07, cabinet-build UL (NEMA) Type 12

Frame size	Height		Width		Depth		Weight	
	in	mm	in	mm	in	mm	lb	kg
R8	84.5	2145	25.4	643	26.5	673	565	255
R9	84.5	2145	25.4	643	26.5	673	605	275
R10	91.2	2315	38.2	968	27.5	698	905	410
R11	91.2	2315	38.2	968	27.5	698	970	440



ACS580-01, wall-mounted UL (NEMA) Type 4X IP66

Frame size	Height (H)		Width (W)		Depth (D1)		Depth (D2)		Weight	
	in	mm	in	mm	in	mm	in	mm	lb	kg
R1	20.55	522	8.19	208	9.79	249	11.05	281	26	11.8
R2	23.86	606	8.19	208	10.22	260	11.48	292	32	14.5
R3	25.47	647	10.91	277	10.25	260	11.40	289	58	26.4

Symbols
 H Height back including cable/conduit box
 W Width
 D1 Depth without disconnect
 D2 Depth with disconnect

ACS580-01, wall-mounted UL (NEMA) Type 4X IP66 with sun shield

Frame size	Height (H)		Width (W)		Depth (D)		Weight	
	in	mm	in	mm	in	mm	lb	kg
R1	24.35	619	11.98	304	16.00	407	33	15.1
R2	27.66	703	11.98	304	16.00	407	39	17.7
R3	29.27	744	15.60	396	16.40	417	76	34.3

Symbols
 H Height back including cable/conduit box
 W Width
 D Depth

Dimensions

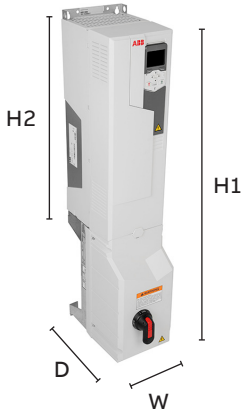

ACS580-OP, packaged drive with disconnect means, UL (NEMA) Type 1

Frame size	Height (H1)		Height (H2)		Width (W1)		Width (W2)		Depth (D)		Weight	
	in	mm	in	mm	in	mm	in	mm	in	mm	lb	kg
R1	24.60	625	12.48	317	6.34	161	3.86	98	12.42	316	18.1	8.2
R2	28.49	725	16.42	417	6.34	161	3.86	98	12.63	321	22.0	10.0
R3	34.86	885	18.75	476	8.39	213	6.30	160	13.22	336	39.0	17.7
R4	40.61	1032	24.49	622	8.39	213	6.30	160	14.26	362	60.0	27.2
R5-R8	47.72	1212	46.26	1175	28.24	717	6.34	600	19.04	484	359.0	163.0

H1 - Height

H2 - Mounting Height

W1 - Width

W2 - Mounting Width

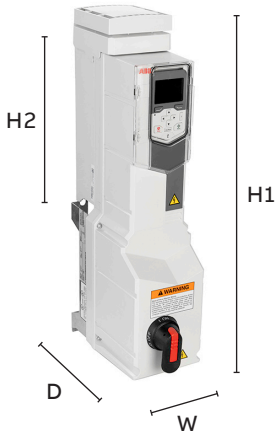

ACS580-OP, packaged drive with disconnect means, UL (NEMA) Type 12

Frame size	Height (H1)		Height (H2)		Width (W1)		Width (W2)		Depth (D)		Weight	
	in	mm	in	mm	in	mm	in	mm	in	mm	lb	kg
R1	26.50	673	12.48	317	6.50	164	3.86	98	12.40	316	18.1	8.2
R2	30.22	768	16.42	417	6.50	164	3.86	98	12.64	321	22.0	10.0
R3	36.51	927	18.75	476	8.39	213	6.30	160	13.22	336	39.0	17.7
R4	42.54	1081	24.49	622	8.39	213	6.30	160	14.26	362	60.0	27.2
R5-R8	48.07	1221	46.26	1175	28.24	717	23.62	600	19.04	484	359.0	163.0

H1 - Height

H2 - Mounting Height

W1 - Width

W2 - Mounting Width

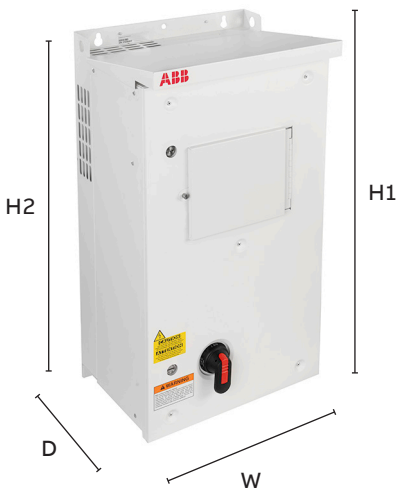

ACS580-OP, packaged drive with disconnect means, UL (NEMA) Type 3R

Frame size	Height (H1)		Height (H2)		Width (W1)		Width (W2)		Depth (D)		Weight	
	in	mm	in	mm	in	mm	in	mm	in	mm	lb	kg
R1-R2	33.35	847	31.90	810	17.7	449	12.60	320	13.98	355	77.0	35.0
R3-R4	40.71	1034	39.30	998	20.71	526	15.70	400	15.40	392	176.0	79.8

H1 - Height

H2 - Mounting Height

W1 - Width

W2 - Mounting Width

Dimensions

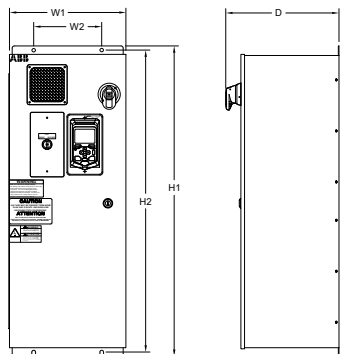

UL Type 1 CX1-21 - CX-23

ACS580-0P, packaged drive with Circuit Breaker Disconnect and Two-Contactor Bypass, UL (NEMA) Type 1

Dimension Reference	Height (H1)		Height (H2)		Width (W1)		Width (W2)		Depth (D)		Weight	
	in	mm	in	mm	in	mm	in	mm	in	mm	lb	kg
CX1-21	36.00	914	35.50	902	13.70	348	8.00	203	13.32	338	90	41
CX1-22	53.44	1357	52.44	1332	16.30	414	10.00	254	14.35	364	175	80
CX1-23	61.87	1571	60.88	1546	19.31	490	10.00	254	18.98	482	375	170
CX1-24	73.44	1865	61.38	1559	34.75	883	26	660	20.4	518	550	250
CX1-25	84	2134	NA	NA	36	914	NA	NA	23.3	592	950	432

H1 - Height
 H2 - Mounting Height
 W1 - Width
 W2 - Mounting Width

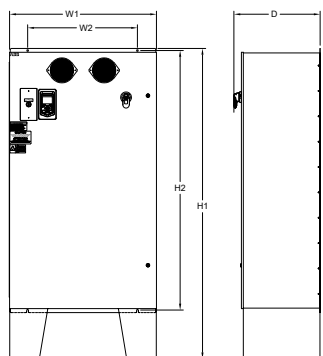

UL Type 1 CX1-24

ACS580-0P, packaged drive with Circuit Breaker Disconnect and Two-Contactor Bypass, UL (NEMA) Type 12

Dimension Reference	Height (H1)		Height (H2)		Width (W1)		Width (W2)		Depth (D)		Weight	
	in	mm	in	mm	in	mm	in	mm	in	mm	lb	kg
CX12-21	24.00	610	22.50	572	18.00	457	16.50	419	15.00	381	85	39
CX12-22	30.00	762	28.50	724	24.00	610	22.50	572	15.00	381	155	70
CX12-23	36.00	914	34.50	876	30.00	762	28.50	724	15.00	381	207	94
CX12-24	48.00	1219	46.50	1181	36.00	914	34.50	876	21.00	533	410	186
CX12-25	72.00	1829	58.60	1488	36.00	914	34.50	876	20.90	531	608	276
CX12-26	84.00	2134	NA	NA	48.00	1219	NA	NA	23.30	592	950	432

H1 - Height
 H2 - Mounting Height
 W1 - Width
 W2 - Mounting Width

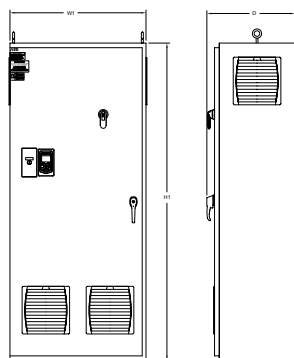

UL Type 1 CX1-25

ACS580-0P, packaged drive with Circuit Breaker Disconnect and Two-Contactor Bypass, UL (NEMA) Type 3R

Dimension Reference	Height (H1)		Height (H2)		Width (W1)		Width (W2)		Depth (D)		Weight	
	in	mm	in	mm	in	mm	in	mm	in	mm	lb	kg
CX3R-21	27.34	694	22.50	572	18.21	463	16.50	419	14.38	365	90	41
CX3R-22	33.00	838	28.50	724	24.00	610	22.50	572	14.37	365	145	66
CX3R-23	39.40	1001	34.50	876	30.00	762	28.50	724	15.87	403	230	105
CX3R-24	51.00	1295	46.50	1181	36.00	914	34.50	876	20.37	517	445	202
CX3R-25	72.00	1829	58.60	1488	42.00	1067	34.5	876	25.10	638	675	307

H1 - Height
 H2 - Mounting Height
 W1 - Width
 W2 - Mounting Width

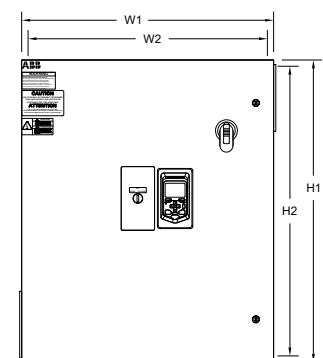

UL Type 12 CX12-21 - CX12-24

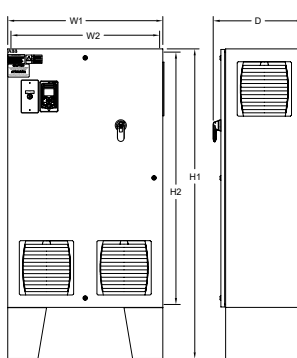
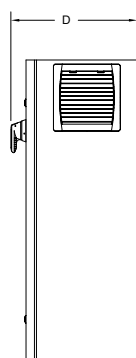

UL Type 12 CX12-25

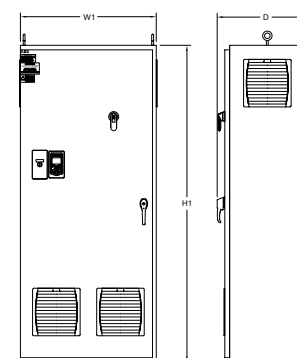

UL Type 12 CX12-26

Ratings, types and voltages

Wall-mounted drives, ACS580-01								
Type code	Max. output current	Nominal Ratings (3-phase)				Nominal Ratings (1-phase)		Base Drive Frame
		Light Duty (10% overload for 1 min)		Heavy Duty (50% overload for 1 min)		I_N (A)	P_N (HP)	
		I_{Ld} (A)	P_{Ld} (HP)	I_{Hd} (A)	P_{Hd} (HP)			
I_{max} (A)	I_{Ld} (A)	P_{Ld} (HP)	I_{Hd} (A)	P_{Hd} (HP)	I_N (A)	P_N (HP)		
3-phase, $U_N = 208/230$ V, 60 Hz								
ACS580-01-04A6-2	6.3	4.6	1	3.5	0.75	2.2	0.50	R1
ACS580-01-06A6-2	8.9	6.6	1.5	4.6	1	3.2	0.75	R1
ACS580-01-07A5-2	11.9	7.5	2	6.6	1.5	4.2	1.0	R1
ACS580-01-10A6-2	14.3	10.6	3	7.5	2	6.0	1.5	R1
ACS580-01-017A-2	22.6	16.7	5	10.6	3	6.8	2.0	R1
ACS580-01-024A-2	32.7	24.2	7.5	16.7	5	9.6	3.0	R2
ACS580-01-031A-2	43.6	30.8	10	24.2	7.5	15.2	5.0	R2
ACS580-01-046A-2	62.4	46.2	15	30.8	10	22.0	7.5	R3
ACS580-01-059A-2	83.2	59.4	20	46.2	15	28.0	10	R3
ACS580-01-075A-2	107	74.8	25	59.4	20	28.0	10	R4
ACS580-01-088A-2	135	88	30	74.8	25	42.0	15	R5
ACS580-01-114A-2	158	114	40	88	30	54.0	20	R5
ACS580-01-143A-2	205	143	50	114	40	68.0	25	R6
ACS580-01-169A-2	257	169	60	143	50	80.0	30	R7
ACS580-01-211A-2	304	211	75	169	60	104.0	40	R7
ACS580-01-273A-2	380	273	100	211	75	130.0	50	R8
ACS580-01-343A-2	491	343	125	273	100	154	60	R9
ACS580-01-396A-2	559	396	150	343 ¹	125	192	75	R9

¹ Maximum current with 40% overload, allowed for one minute every ten minutes

² Maximum current with 30% overload, allowed for one minute every ten minutes

³ Maximum current with 25% overload, allowed for one minute every ten minutes

Wall-mounted drives, ACS580-01						
Type code	Max. output current	Nominal Ratings (3-phase)				Base Drive Frame
		Light Duty (10% overload for 1 min)		Heavy Duty (50% overload for 1 min)		
		I_{Ld} (A)	P_{Ld} (HP)	I_{Hd} (A)	P_{Hd} (HP)	
I_{max} (A)	I_{Ld} (A)	P_{Ld} (HP)	I_{Hd} (A)	P_{Hd} (HP)		
3-phase, $U_N = 480$ V (range 380 to 480 V)						
ACS580-01-02A1-4	2.9	2.1	1	1.6	0.75	R1
ACS580-01-03A0-4	4.1	3	1.5	2.1	1	R1
ACS580-01-03A5-4	5.4	3.5	2	3	1.5	R1
ACS580-01-04A8-4	6.5	4.8	3	3.4	2	R1
ACS580-01-06A0-4	8.6	6	3	4	3	R1
ACS580-01-07A6-4	11	7.6	5	4.8	3	R1
ACS580-01-012A-4	16	12	7.5	7.6	5	R1
ACS580-01-014A-4	22	14	10	11	7.5	R2
ACS580-01-023A-4	31	23	15	14	10	R2
ACS580-01-027A-4	41	27	20	21	15	R3
ACS580-01-034A-4	49	34	25	27	20	R3
ACS580-01-044A-4	61	44	30	34	25	R3
ACS580-01-052A-4	79	52	40	40	30	R4
ACS580-01-065A-4	94	65	50	52	40	R4
ACS580-01-077A-4	117	77	60	65	50	R4
ACS580-01-078A-4	117	77	60	65	50	R5
ACS580-01-096A-4	139	96	75	77	60	R5
ACS580-01-124A-4	173	124	100	96	75	R6
ACS580-01-156A-4	223	156	125	124	100	R7
ACS580-01-180A-4	281	180	150	156	125	R7
ACS580-01-240A-4	324	240	200	180	150	R8
ACS580-01-260A-4	418	260	200	240 ²	150	R8
ACS580-01-302A-4	468	302	250	260	200	R9
ACS580-01-361A-4	544	361	300	302	250	R9
ACS580-01-414A-4	560	414	350	361 ³	300	R9

*See notes and definitions on page <?>.

Ratings, types and voltage

Wall-mounted drives, ACS580-01						
Type code	Max. output current	Nominal Ratings (3-phase)				Base Drive Frame
		Light Duty (10% overload for 1 min)		Heavy Duty (50% overload for 1 min)		
	I_{max} (A)	I_{Ld} (A)	P_{Ld} (HP)	I_{Hd} (A)	P_{Hd} (HP)	
3-phase, $U_N = 600$ V (range 500 to 600 V)						
ACS580-01-02A7-6	4.3	2.7	2	2.4	1.5	R2
ACS580-01-03A9-6	5.3	3.9	3	2.7	2	R2
ACS580-01-06A1-6	8.2	6.1	5	3.9	3	R2
ACS580-01-09A0-6	12.2	9	7.5	6.1	5	R2
ACS580-01-011A-6	16.2	11	10	9	7.5	R2
ACS580-01-017A-6	23	17	15	11	10	R2
ACS580-01-022A-6	30.6	22	20	17	15	R3
ACS580-01-027A-6	39.6	27	25	22	20	R3
ACS580-01-032A-6	48.6	32	30	27	25	R3
ACS580-01-041A-6	58	41	40	32	30	R5
ACS580-01-052A-6	74	52	50	41	40	R5
ACS580-01-062A-6	94	62	60	52	50	R5
ACS580-01-077A-6	112	77	75	62	60	R5
ACS580-01-099A-6	139	99	100	77	75	R7
ACS580-01-125A-6	178	125	125	99	100	R7
ACS580-01-144A-6	225	144	150	125	125	R8
ACS580-01-192A-6	259	192	200	144	150	R9
ACS580-01-242A-6	346	242	250	192	200	R9
ACS580-01-271A-6	411	271	250	210	200	R9

Notes:

- Ratings apply at an ambient temperature of 40°C (104°F).

- To achieve the rated motor power given in the table, the rated current of the drive must be higher than or equal to the rated motor current.

¹ Maximum current with 40% overload, allowed for one minute every ten minutes

² Maximum current with 30% overload, allowed for one minute every ten minutes

³ Maximum current with 25% overload, allowed for one minute every ten minutes

Definitions:

I_{LD} Continuous rms output current allowing 10% overload for 1 minute every 5 minutes.

P_{LD} Typical motor power in light-overload use.

I_{HD} Continuous rms output current allowing 50% overload for 1 minute every 5 minutes.

P_{HD} Typical motor power in heavy-duty use.

Ratings, types and voltages

Cabinet-built single drives, ACS580-07						
Type Code	Max. output current	Nominal Ratings				Base Drive Frame
		Light Duty (10% overload for 1 min)		Heavy Duty (50% overload for 1 min)		
		I_{MAX} (A)	I_{Ld} (A)	P_{Ld} (HP)	I_{Hd} (A)	
$U_N = 500$ V (range 380 to 500 V)						
ACS580-07-0246A-4+B055+C129+H351+H353+H358	350	240	200	180	150	R8
ACS580-07-0363A-4+B055+C129+H351+H353+H358	498	361	300	302	250	R9
ACS580-07-0430A-4+B055+C129+H351+H353+H358	542	414	350	361*	300	R9
ACS580-07-0505A-4+B055+C129+H351+H353+H358	560	483	400	361	300	R10
ACS580-07-0585A-4+B055+C129+H351+H353+H358	730	573	450	414	350	R10
ACS580-07-0650A-4+B055+C129+H351+H353+H358	730	623	500	477	400	R10
ACS580-07-0725A-4+B055+C129+H351+H353+H358	850	705	600	566	450	R11
ACS580-07-0820A-4+B055+C129+H351+H353+H358	1020	807	700	625	500	R11

Notes:

* Continuous current allowing 25% overload for 1 minute every 10 minutes at 40°C.

- Ratings apply at an ambient temperature of 40°C (104°F).

- To achieve the rated motor power given in the table, the rated current of the drive must be higher than or equal to the rated motor current.

Definitions:

I_{LD} Continuous rms output current allowing 10% overload for 1 minute every 5 minutes.

P_{LD} Typical motor power in light-overload use.

I_{HD} Continuous rms output current allowing 50% overload for 1 minute every 5 minutes.

P_{HD} Typical motor power in heavy-duty use.

Ratings, types and voltages

Packaged drive with disconnect means								
Type Code	Max output current	Nominal Ratings (3-phase)				Nominal Ratings (1-phase)		Base Drive Frame
		Light Duty (10% overload for 1 min)		Heavy Duty (50% overload for 1 min)		I_N (A)	P_N (HP)	
		I_{Ld} (A)	P_{Ld} (HP)	I_{Hd} (A)	P_{Hd} (HP)			
$U_N = 230\text{ V}$ (range 208 to 240V)								
ACS580-0P-04A6-2	6.3	4.6	1	3.5	0.75	2.2	0.50	R1
ACS580-0P-06A6-2	8.9	6.6	1.5	4.6	1	3.2	0.75	R1
ACS580-0P-07A5-2	11.9	7.5	2	6.6	1.5	4.2	1.0	R1
ACS580-0P-10A6-2	14.3	10.6	3	7.5	2	6.0	1.5	R1
ACS580-0P-017A-2	22.6	16.7	5	10.6	3	6.8	2.0	R1
ACS580-0P-024A-2	32.7	24.2	7.5	16.7	5	9.6	3.0	R2
ACS580-0P-031A-2	43.6	30.8	10	24.2	7.5	15.2	5.0	R2
ACS580-0P-046A-2	62.4	46.2	15	30.8	10	22.0	7.5	R3
ACS580-0P-059A-2	83.2	59.4	20	46.2	15	28.0	10	R3
ACS580-0P-075A-2	107	74.8	25	59.4	20	28.0	10	R4
ACS580-0P-088A-2	135	88	30	74.8	25	42.0	15	R5
ACS580-0P-114A-2	158	114	40	88	30	54.0	20	R5
ACS580-0P-143A-2	205	143	50	114	40	68.0	25	R6
ACS580-0P-169A-2	257	169	60	143	50	80.0	30	R7
ACS580-0P-211A-2	304	211	75	169	60	104.0	40	R7
ACS580-0P-248A-2	380	273	100	211	75	130.0	50	R8

Packaged drive with disconnect means							
Type Code	Max output current	Nominal Ratings (3-phase)				Base Drive Frame	
		Light Duty (10% overload for 1 min)		Heavy Duty (50% overload for 1 min)			
		I_{Ld} (A)	P_{Ld} (HP)	I_{Hd} (A)	P_{Hd} (HP)		
$U_N = 480\text{ V}$ (range 380 to 500 V)							
ACS580-0P-02A1-4	2.9	2.1	1	1.6	0.75	R1	
ACS580-0P-03A0-4	3.8	3	1.5	2.1	1	R1	
ACS580-0P-03A5-4	5.4	3.5	2	3	1.5	R1	
ACS580-0P-04A8-4	6.1	4.8	3	3.4	2	R1	
ACS580-0P-07A6-4	8.6	7.6	5	4.8	3	R1	
ACS580-0P-012A-4	11.4	12	7.5	7.6	5	R1	
ACS580-0P-014A-4	19.8	14	10	11	7.5	R2	
ACS580-0P-023A-4	25.2	23	15	14	10	R2	
ACS580-0P-027A-4	37.8	27	20	21	15	R3	
ACS580-0P-034A-4	48.6	34	25	27	20	R3	
ACS580-0P-044A-4	61.2	44	30	34	25	R3	
ACS580-0P-052A-4	76	52	40	40	30	R4	
ACS580-0P-065A-4	104	65	50	52	40	R4	
ACS580-0P-077A-4	122	77	60	65	50	R4	
ACS580-0P-096A-4	148	96	75	77	60	R5	
ACS580-0P-124A-4	178	124	100	96	75	R6	
ACS580-0P-156A-4	247	156	125	124	100	R7	
ACS580-0P-180A-4	287	180	150	156	125	R7	
ACS580-0P-240A-4	350	240*	200	180	150	R8	

Ratings, types and voltages

Packaged drive with disconnect means						
Type Code	Max output current	Nominal Ratings (3-phase)			Base Drive Frame	
		Light Duty (10% overload for 1 min)		Heavy Duty (50% overload for 1 min)		
	I_{MAX} (A)	I_{Ld} (A)	P_{Ld} (HP)	I_{Hd} (A)	P_{Hd} (HP)	
$U_N = 600$ V (range 500 to 600 V)						
ACS580-0P-02A7-6	4.3	2.7	2	2.4	1.5	R2
ACS580-0P-03A9-6	5.3	3.9	3	2.7	2	R2
ACS580-0P-06A1-6	8.2	6.1	5	3.9	3	R2
ACS580-0P-09A0-6	12.2	9	7.5	6.1	5	R2
ACS580-0P-011A-6	16.2	11	10	9	7.5	R2
ACS580-0P-017A-6	23	17	15	11	10	R2
ACS580-0P-022A-6	30.6	22	20	17	15	R3
ACS580-0P-027A-6	39.6	27	25	22	20	R3
ACS580-0P-032A-6	48.6	32	30	27	25	R3
ACS580-0P-041A-6	58	41	40	32	30	R5
ACS580-0P-052A-6	74	52	50	41	40	R5
ACS580-0P-062A-6	94	62	60	52	50	R5
ACS580-0P-077A-6	112	77	75	62	60	R5
ACS580-0P-099A-6	139	99	100	77	75	R7
ACS580-0P-125A-6	178	125	125	99	100	R7
ACS580-0P-144A-6	225	144	150	125	125	R8

Notes:

* Continuous current allowing 25% overload for 1 minute every 10 minutes at 40°C.

- Ratings apply at an ambient temperature of 40°C (104°F).

- To achieve the rated motor power given in the table, the rated current of the drive must be higher than or equal to the rated motor current.

Definitions:

I_{LD} Continuous rms output current allowing 10% overload for 1 minute every 5 minutes.

P_{LD} Typical motor power in light-overload use.

I_{HD} Continuous rms output current allowing 50% overload for 1 minute every 5 minutes.

P_{HD} Typical motor power in heavy-duty use.

Ratings, types and voltages

ACS580-0P, packaged drive with Circuit Breaker Disconnect and Two-Contactor Bypass									
Type code	Max. output current	Nominal ratings				Base Drive Frame	UL	UL	UL
		Light duty (10% overload for 1 min)		Heavy duty (50% overload for 1 min)			Type 1	Type 12	Type 3R
	I_{max} (A)	I_{LD} (A)	P_{LD} (HP)	I_{HD} (A)	P_{HD} (HP)		Dim Ref	Dim Ref	Dim Ref
$U_N = 240$ VAC (range 208 to 240 VAC). Power ratings are valid at nominal voltage									
ACS580-0P-04A6-2+F255+G310	4.6	4.6	1	3.5	0.8	R1	CX1-21	CX12-21*	TBD
ACS580-0P-06A6-2+F255+G310	6.6	6.6	1.5	4.6	1	R1	CX1-21	CX12-21*	TBD
ACS580-0P-07A5-2+F255+G310	7.5	7.5	2	6.6	1.5	R1	CX1-21	CX12-21*	TBD
ACS580-0P-10A6-2+F255+G310	10.6	10.6	3	7.5	2	R1	CX1-21	CX12-21*	TBD
ACS580-0P-017A-2+F255+G310	16.7	16.7	5	10.6	3	R1	CX1-21	CX12-21*	TBD
ACS580-0P-024A-2+F255+G310	24.2	24.2	7.5	16.7	5	R2	CX1-21*	CX12-22	TBD
ACS580-0P-031A-2+F255+G310	30.8	30.8	10	24.2	7.5	R2	CX1-21*	CX12-22	TBD
ACS580-0P-046A-2+F255+G310	46.2	46.2	15	30.8	10	R3	CX1-22	CX12-22	TBD
ACS580-0P-059A-2+F255+G310	59.4	59.4	20	46.2	15	R3	CX1-22	CX12-22	TBD
ACS580-0P-075A-2+F255+G310	74.8	74.8	25	59.4	20	R4	CX1-22	CX12-24	TBD
ACS580-0P-088A-2+F255+G310	88	88	30	74.8	25	R5	CX1-23	CX12-24	TBD
ACS580-0P-114A-2+F255+G310	114	114	40	88	30	R5	CX1-23	CX12-24	TBD
ACS580-0P-143A-2+F255+G310	143	143	50	114	40	R6	CX1-23	CX12-24	TBD
ACS580-0P-169A-2+F255+G310	169	169	60	143	50	R7	CX1-24	CX12-24	TBD
ACS580-0P-211A-2+F255+G310	211	211	75	169	60	R7	CX1-24	CX12-25*	TBD
ACS580-0P-273A-2+F255+G310	273	273	100	192	75	R8	CX1-24	CX12-25*	TBD
$U_N = 460$ V									
ACS580-0P-02A1-4+F255+G310	2.1	2.1	1	1.6	0.75	R1	CX1-21	CX12-21*	TBD
ACS580-0P-03A0-4+F255+G310	3	3	1.5	2.1	1	R1	CX1-21	CX12-21*	TBD
ACS580-0P-03A5-4+F255+G310	3.5	3.5	2	3	1.5	R1	CX1-21	CX12-21*	TBD
ACS580-0P-04A8-4+F255+G310	4.8	4.8	3	3.4	2	R1	CX1-21	CX12-21*	TBD
ACS580-0P-07A6-4+F255+G310	7.6	7.6	5	4.8	3	R1	CX1-21	CX12-21*	TBD
ACS580-0P-012A-4+F255+G310	12	12	7.5	7.6	5	R1	CX1-21	CX12-21*	TBD
ACS580-0P-014A-4+F255+G310	14	14	10	11	7.5	R2	CX1-21*	CX12-22	TBD
ACS580-0P-023A-4+F255+G310	23	23	15	14	10	R2	CX1-21*	CX12-22	TBD
ACS580-0P-027A-4+F255+G310	27	27	20	21	15	R3	CX1-22	CX12-22	TBD
ACS580-0P-034A-4+F255+G310	34	34	25	27	20	R3	CX1-22	CX12-22	TBD
ACS580-0P-044A-4+F255+G310	44	44	30	34	25	R3	CX1-22	CX12-22	TBD
ACS580-0P-052A-4+F255+G310	52	52	40	40	30	R4	CX1-22	CX12-23	TBD
ACS580-0P-065A-4+F255+G310	65	65	50	52	40	R4	CX1-22	CX12-23*	TBD
ACS580-0P-077A-4+F255+G310	77	77	60	65	50	R4	CX1-22	CX12-24	TBD
ACS580-0P-096A-4+F255+G310	96	96	75	77	60	R5	CX1-23	CX12-24	TBD
ACS580-0P-124A-4+F255+G310	124	124	100	96	75	R6	CX1-23	CX12-24	TBD
ACS580-0P-156A-4+F255+G310	156	156	125	124	100	R7	CX1-24	CX12-24	TBD
ACS580-0P-180A-4+F255+G310	180	180	150	156	125	R7	CX1-24	CX12-24	TBD
ACS580-0P-240A-4+F255+G310	240	240	200	180	150	R8	CX1-24*	CX12-25*	TBD
ACS580-0P-302A-4+F255+G310	302	302	250	240	200	R9	CX1-25	CX12-26	TBD
ACS580-0P-361A-4+F255+G310	361	361	300	302	250	R9	CX1-25	CX12-26	TBD
ACS580-0P-414A-4+F255+G310	414	414	350	361	300	R9	CX1-25	CX12-26	TBD

Ratings, types and voltages

ACS580-0P, packaged drive with Circuit Breaker Disconnect and Two-Contactor Bypass									
Type code	Max. output current	Nominal ratings				Base Drive Frame	UL	UL	UL
		Light duty (10% overload for 1 min)		Heavy duty (50% overload for 1 min)			Type 1	Type 12	Type 3R
	I_{max} (A)	I_{LD} (A)	P_{LD} (HP)	I_{HD} (A)	P_{HD} (HP)		Dim Ref	Dim Ref	Dim Ref
$U_N = 575$ V Wye									
ACS580-0P-02A7-6+F255+G310	2.7	2.7	2	2.4	1.5	R2	CX1-21*	CX12-22	TBD
ACS580-0P-03A9-6+F255+G310	3.9	3.9	3	2.7	2	R2	CX1-21*	CX12-22	TBD
ACS580-0P-06A1-6+F255+G310	6.1	6.1	5	3.9	3	R2	CX1-21*	CX12-22	TBD
ACS580-0P-09A0-6+F255+G310	9	9	7.5	6.1	5	R2	CX1-21*	CX12-22	TBD
ACS580-0P-011A-6+F255+G310	11	11	10	9	7.5	R2	CX1-21*	CX12-22	TBD
ACS580-0P-017A-6+F255+G310	17	17	15	11	10	R2	CX1-21*	CX12-22	TBD
ACS580-0P-022A-6+F255+G310	22	22	20	17	15	R3	CX1-22	CX12-22	TBD
ACS580-0P-027A-6+F255+G310	27	27	25	22	20	R3	CX1-22	CX12-22	TBD
ACS580-0P-032A-6+F255+G310	32	32	30	27	25	R3	CX1-22	CX12-22	TBD
ACS580-0P-041A-6+F255+G310	41	41	40	32	30	R5	CX1-22	CX12-23	TBD
ACS580-0P-052A-6+F255+G310	52	52	50	41	40	R5	CX1-22	CX12-23*	TBD
ACS580-0P-062A-6+F255+G310	62	62	60	52	50	R5	CX1-22	CX12-24	TBD
ACS580-0P-077A-6+F255+G310	77	77	75	62	60	R5	CX1-23	CX12-24	TBD
ACS580-0P-099A-6+F255+G310	99	99	100	77	75	R7	CX1-24	CX12-24	TBD
ACS580-0P-125A-6+F255+G310	125	125	125	99	100	R7	CX1-24	CX12-24	TBD
ACS580-0P-144A-6+F255+G310	144	144	150	125	125	R8	CX1-24*	CX12-24	TBD

*Enclosure size increases by one size when line reactor (E213) and/or drive output filter (E205) is added

Simplicity on a whole new level



The assistant control panel's intuitive user interface, assistants and ready-made macros offer simplicity for everyday life. The panel guides you through commissioning without a need to know any drive parameters and offers help when you need it.

Assistant control panel, ACS-AP-5

Set up the drive, fine-tune motor control and monitor values that matter using the assistant control panel, delivered as standard with all ACS580 drives. The assistant control panel can also be used with ACS380.

Commission without a hassle

Select language, set time and date, name the drive, enter motor values, test rotating the motor.

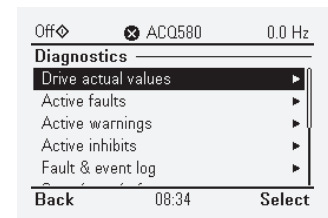
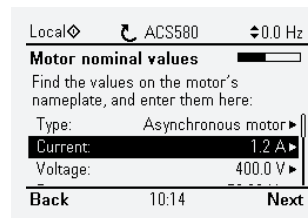
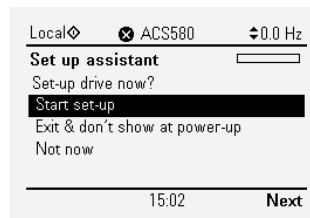

Primary settings

Select ready-made macros, perform ID-run, fine-tune settings related to e.g. ramps, limits, PIDs, fieldbuses, reset to defaults.

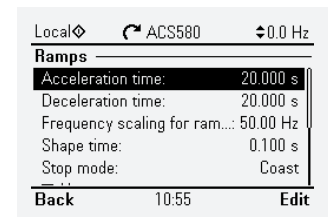
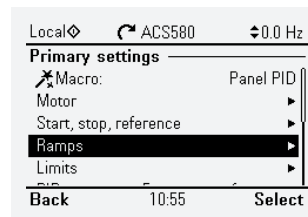
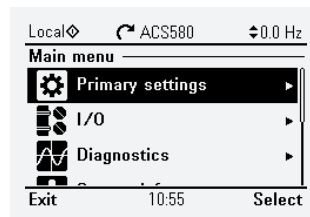

Input/output menu

Set and monitor your input/output (I/O) connections for real-time diagnostics

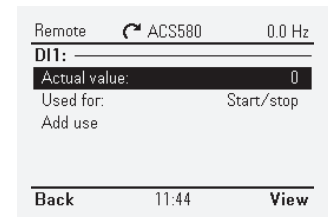
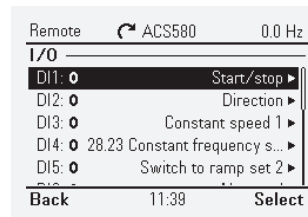
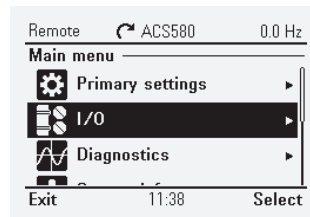

Home view displays

Monitor the values that are the most important to you. You can select values for monitoring from a ready-made list or choose user-defined parameters.

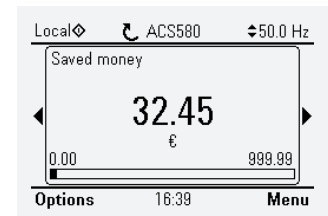
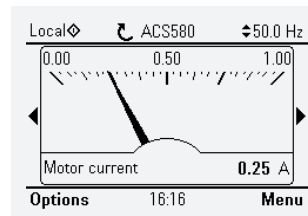
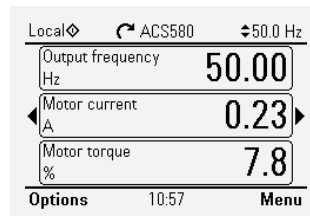

Help button

The help button provides more information about your selection and it can be pressed in any view.

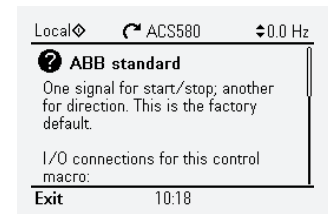
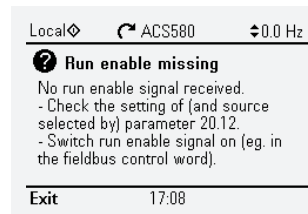
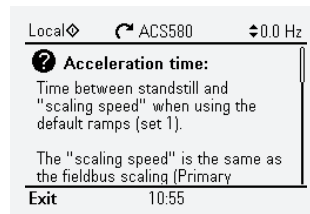

Control panel options and mounting kits

The standard delivery of the ACS580 includes the assistant control panel, but it can also be replaced by other control panels.



Bluetooth control panel, ACS-AP-W ^{*)}

The optional Bluetooth panel enables connection with the Drivetune mobile app. The app is available for free from Google Play and the Apple App store. Together with the Drivetune app and the Bluetooth panel, users can, for example, commission and monitor the drive remotely.



Control panel mounting platform, DPMP-01 Type 12 / IP54 ¹

This mounting platform is flush mount and includes the EMC shield and cable. Ideal for when EMC shielding is required.



Industrial control panel, ACS-AP-I ^{*)}

The industrial control panel is compatible with all ABB drives, making it simple to use a single panel with different products.



Door mounting kit, DPMP-EXT Type 12 / IP65 ¹

The door mounting kit is ideal for cabinet installations. A kit for one drive includes one DPMP-02 and one CDPI-01 (blank control panel cover with RJ-45 connector). If a different control panel than the assistant panel is desired for cabinet door installation, it must be ordered separately.



Panel bus adapter, CDPI-01, CDPI-02

The panel bus adapter is an ideal choice if there is a need to control multiple drives with a single control panel, connect a door mounting kit to the drive or to connect a PC to the drive.



Control panel mounting kit for outdoor installation DPMP-04 Type 4X / IP66

Enables outdoor mounting of the control panel with clear plastic lockable cover, UV resistance and IK07 impact protection rating. Includes 3m cable. (UL Type 3, 3R, 4, and 4X)



Blank control panel, CDUM-01

The blank control panel can be used for covering the control panel slot if no control panel or panel bus adapter is needed.



Door mounting kit, DPMP-08-EXT Type 4X / IP69k

Surface mount, especially for food and beverage applications, NSF169 rated for splash zones, washdown duty, chemical resistant, not UV resistant; Includes RJ45-to-RJ45 3m cable and CDPI-01 panel bus adapter.

Also available: DPMP-06-EXT Type 12 flush mount with cable and CDPI-01 panel bus adapter.

¹When control panel or blank is in place.

Door mounting and daisy chaining

Improve safety and leverage the full potential of the ACS580 control panel options with a door mounting kit and panel bus adapter.



Door mounting fosters easy operation and safety. It enables you to operate the drive without opening the cabinet door, saving time and keeping all the electronics behind the closed door. Up to 32 drives can be connected to one control panel for even

easier and quicker operation. When daisy chaining the drives, you need only one assistant control panel .

The rest of the drives can be equipped with panel bus adapters.

Cabinet door

Door mounting kit

Any DPMP kit with ending -EXT includes the mounting platform, panel bus adapter (CDPI-01/02) and an RJ-45 cable for connecting the control panel and the panel bus adapter.

Assistant control panel

The assistant control panel is delivered as standard with the ACS580 drives . Also a Bluetooth or industrial control panel can be used.

RJ-45 cable for daisy chaining drives

Panel bus adapter, CDPI-01/02

Used to connect a remote control panel or a PC to the drive, or to connect the control panel to several drives on a panel bus. The panel bus can have a maximum of 32 nodes.



Cabinet, outside

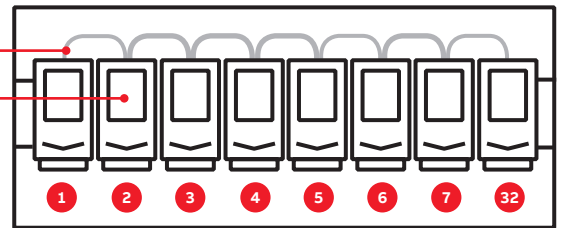

Cabinet, inside

Control panel options

The ACS-AP-S assistant control panel (plus code +J400) is included as standard in the delivery . If no code is mentioned in the ACS580 order, the assistant control panel is automatically added to the delivery. It can be replaced by one of the other +Jxxx options listed below.

Plus code	Description	Type designation
Standard	Assistant control panel ^{*)}	ACS-AP-S
+J429	Control panel with Bluetooth interface ^{*/**)}	ACS-AP-W
+J425	Industrial assistant control panel ^{*/**)}	ACS-AP-I
+J424	Blank control panel cover (no control panel delivered)	CDUM-01
-	Panel bus adapter	CDPI-01/02
-	Control panel mounting platform , Type 12 (IP54) (flush mounted, requires also panel bus adapter on the drive)	DPMP-01
-	Control panel mounting platform with adapter, Type 12 (IP65) (surface mounted)	DPMP-EXT
-	Control panel mounting kit for outdoor installation , Type 4X (IP66)	DPMP-04
-	Control panel mounting platform (flush mount) with adapter, Type 12	DPMP-06-EXT
-	NSF 169 control panel mounting platform (surface mount) with adapter, Type 4X (IP69k)	DPMP-08-EXT

^{*)} Compatible with ACS880 drives

^{**)} Compatible with the ACS380

Higher enclosure classes for cabinet-free installations even in harsh conditions

Don't let dust, moisture or dirt interrupt your processes and drag down productivity. ACS580 UL (NEMA) Type 12 / IP55 and UL (NEMA) Type 4X / IP66 units keep your systems running even in tough conditions.

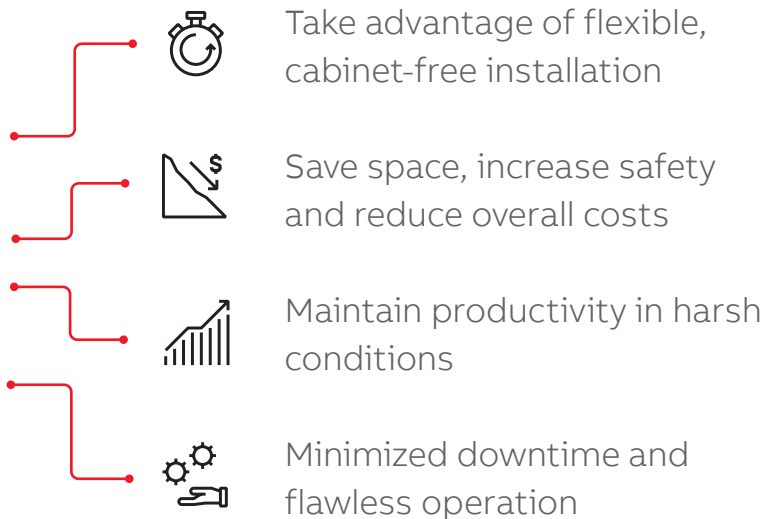

Compact units for rough environments

The ACS580 UL Type 12 (IP55) and UL Type 4X (IP66) units are an ideal choice for harsh environments, where impurities, such as dust or dirt waft in the air. Typical harsh environments include textile, cement, metal and wood processing industries and harsh outdoor conditions in desert and tropical environments. Higher protection class ensures smooth processes by reducing downtime.

These units can be installed directly on the wall closer to the motor, which provides flexibility and simplifies installation. The robust, protective design ensures that no additional enclosures or components, such as dust filters and fans, are needed.

UL (NEMA) Type 12 / IP55

If the environment around your processes includes impurities, drives with lesser enclosure ratings are more likely to fail because they are not designed for harsh environments. A failure causes an interruption and instantly cuts down productivity

and adds costs. Coated control boards of the ACS580 UL (NEMA) Type 12 / IP55 units, increased use of plastics with smart design, and fully gasketed control panel section that maintains the IP rating even if the control panel is removed help keep your processes up and running in tough environments.

Installing the drive closer to the motor allows shorter motor cables to be used. Shorter cables not only cost less and are easier to handle, but they make it easier to fulfill EMC requirements and reduce the need for additional filters.

Cost reductions take place also by eliminating the need for a cabinet. UL (NEMA) Type 12 / IP55 drives provides protection from dust and jetting water from any direction. Speed-controlled main cooling fans maintain optimal drive operating temperatures without a need for external cooling. Keeping the drive at optimal temperature increases the lifetime of the drive.

UL (NEMA) Type 4X / IP66 drives for indoor washdown and outdoor installations

Designed for extreme environments, the UL Type 4X (IP66) ACS580-01 drive is well suited for outdoor spaces and wet locations. This drive is at home outdoors in all types of weather and indoors where cleaning is a daily occurrence or where it almost never happens.



Use it indoors or outdoors in extreme environments without a cabinet

Add the optional input disconnect switch to simplify installation and save on cost

No learning curve since the same control program, digital tools and adapter modules are used with UL Type 1 and 12 (IP21 and IP55)

A drive for extreme environments

ACS580 UL (NEMA) Type 4X / IP66 is the drive to use for locations close to the action where things can get messy. The drive housing protects against water and other liquids, is resistant to weather like sun, rain, ice and snow, and resistant to a variety of common chemicals and salt spray. All this, coupled with easy installation and commissioning makes this the ideal drive for extreme environments.

The ACS580 UL Type 4X / IP66 drive with air-over cooling is indoor/outdoor rated and is fully sealed against hose-directed spray. The drive is available from 1 to 30 HP (.75 to 22 kW). It is corrosion-resistant and UV resistant to the same standard as a stainless-steel enclosure.

The best choice for a variety of locations

- Food and beverage
 - NSF 169 certified for splash zones where daily washdown is common
 - Refrigeration down to -15 °C
 - Cattle, hog and poultry barns
 - Pump carts for brewers and distillers
- Irrigation for greenhouses and aquaculture
- Dewatering, agriculture and turf management

Ease of Installation and reduced cost

The drive can optionally include a lockable input disconnect switch and fuses to simplify installation and reduce the cost. The UL98 disconnect is more robust, eliminating the need for branch circuit fuses to meet NEC regulations while maintaining 100 kA SCCR. Enhanced control algorithms provide flexibility that enables reduction of CAPEX and OPEX Costs.

Easy to use

The same standard control program is used throughout the ACS580 drive series making it easy for operators and maintenance personnel. And the same digital tools and optional fieldbus and I/O adapters are used as well. Learn it once; use it everywhere.

Bluetooth control panel as standard

The all-compatible Bluetooth panel securely connects to your smartphone or PC making it easy to start up, commission and tune the drive with Drive Composer or Drivetune and remotely connect to ABB Ability™ Mobile Connect, the same tools as other all-compatible drives. Stay safely out of the arc flash boundary by connecting up to 250 ft (75 m) away.

Indoor use

For food and beverage applications, the drive is designed to be easy to clean, making it well suited for indoor locations where frequently exposed to common cleaning and sanitizing agents and hose rinse-off. It is equally well suited for farm environments where cleaning may be infrequent and incidental contact with dust, dirt, soil and waste is common.

Outdoor use

This drive is designed to be used outdoors. The entire surface is UV resistant, and a bug screen is standard. The optional sun shield reduces solar heat load on the drive and offers protection from falling debris. The surface has been tested against exposure to corrosive agents such as salt spray, ammonia, chlorine, sanitizers, degreasers, algaecides and microbicides.

Cabinet installation

Adding the flange mount option allows the drive to be mounted through the back wall of the cabinet allowing the drive to expel up to 85% of its heat outside. This reduces cabinet size and cooling requirements and allows the full cabinet to be rated for UL Type 4X (IP66).

Same great essential features inside

- Integrated safe torque off (STO)
- Overload protection
- Optimized DC choke
- Built-in brake chopper
- Integrated EMC filter
- Coated boards
- Color-coded terminals
- Two option slots (fieldbus; I/O extension)
- Controllable cooling fan
- Support for various motor types including asynchronous, permanent magnet, SynRM, EC Titanium and optimum pole motors
- External +24 V AC/DC with CMOD-01 option
- Adaptive programming



ACS580-07 cabinet-built drives

Effortless process automation in a ready-made cabinet

The ACS580-07 is part of the all-compatible family and a cabinet-built extension to the ACS580 series. They are suited for many different applications, easy to use, order and maintain, and they are quickly available. The simple and robust design ensures reliable operation even in dusty environments. The cabinets are compact in size, including flange mounting (R6-R9) and optimized cooling system as standard.

For many purposes: The ACS580-07 is ready to control many applications including mixers, extruders, compressors, centrifuges, and fans.



Easy to order: Packed with standard features: Through-the-door disconnect switch, EMC filter, optimized DC choke, common mode filter (>300 hp), assistant control panel, Modbus RTU, STO and installation tools are included as standard, Wide selection of fieldbuses and input/output options is available.



Fast to get: Cabinet-built ACS580-07 drives are delivered fast from the factory.



Easy to use: Application control is easy to setup through the assistant control panel. Also other all-compatible ACS580 user interfaces can be used including the popular Bluetooth control panel.



Easy to maintain: Smartly positioned fans and filters ensure the longevity of the drive and its components. When it is time to do maintenance, the necessary components are in easily accessible locations.



UL listed: All cabinet-built ACS580-07 drives are UL listed and built in UL 508A certified panel shops.



Thermal tested: The thermal properties are tested in accordance to IEC 61800-5-1:2007. 2012 standards to ensure the environment and operators stay safe in all operating conditions. Be it a premature fan failure or clogged environmental filters to restrict the cooling capabilities, the tests verify that the equipment is self-protecting it at all times.



Adaptable to harsh environments: UL Type 12 (IP54) integrity as standard and unique cooling system ensure the units stay cool even in dusty environments



Standard factory-installed features: Compact UL Type 12 enclosure, through-the-door disconnect, fast acting UL fuses, coated circuit boards, safe torque off (STO), DC choke, EMC filter, common mode filter (>300 HP) and support for various motor types including induction, permanent magnet synchronous and ABB synchronous reluctance motors.



Frame sizes R8-R9

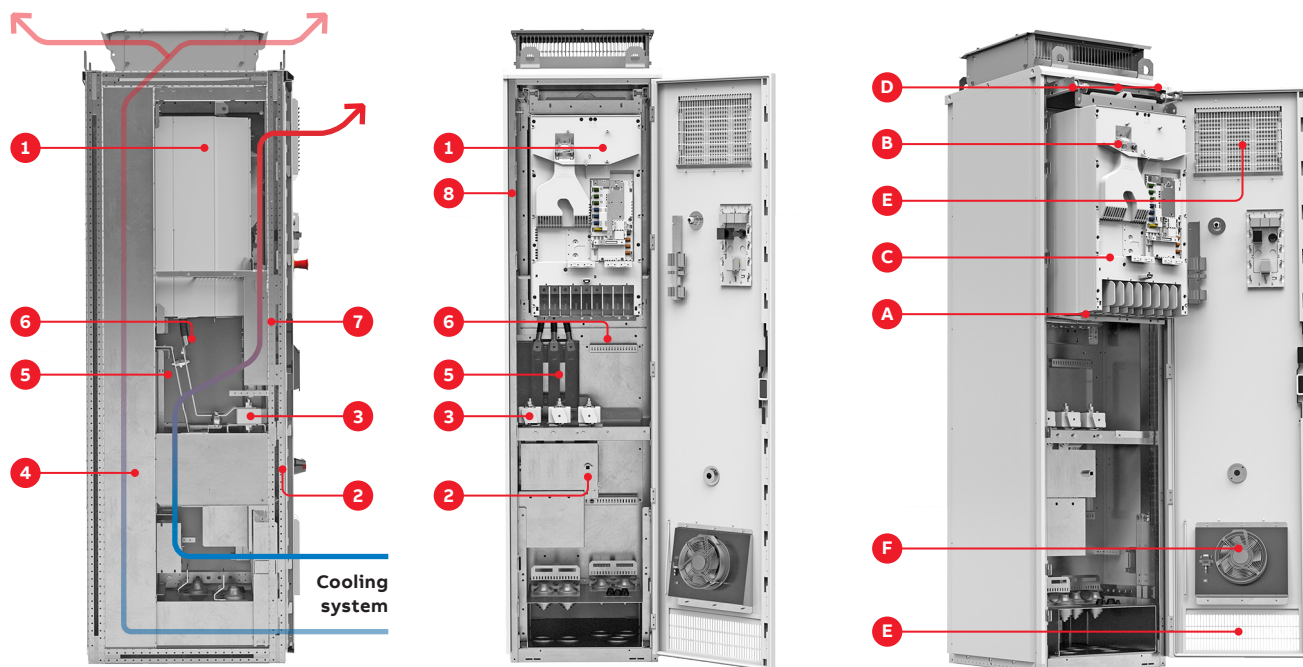

Frame sizes R10-R11

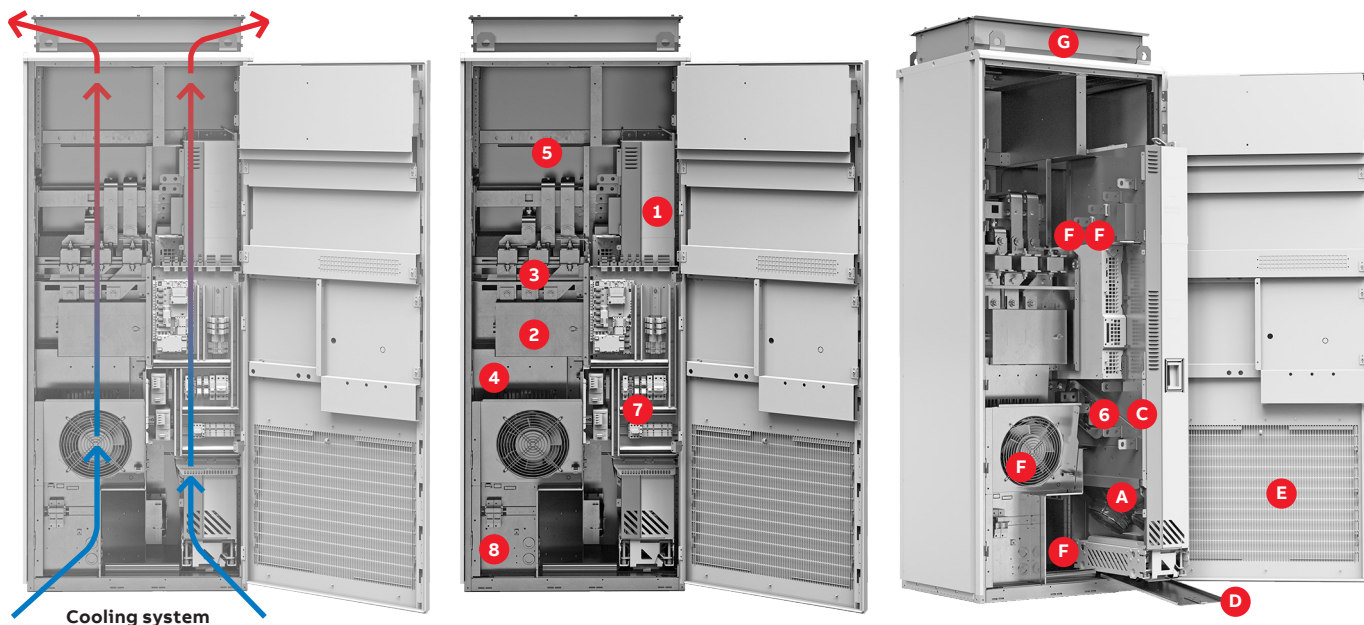

Cabinet components

1. Module
2. Main switch or MCC8, option +F289
3. Fuses
4. Space for optional du/dt filter or cabinet resistors
5. Space for a line contactor option +F250
6. Common mode filter allocation
7. Space for safety, ATEX or external power supply options
8. Space for options +M600...+M605

Maintenance operation components

- A Main fans
- B Auxiliary fans
- C Capacitors (inside the module)
- D Rails and ramp supporting maintenance operation
- E Filters for dust and external components
- F Other supporting fans for R10 and R11
- G Roof top for R10 and R11 (only IP54)

Commissioning, programming and customization tools

Your engineering efficiency is boosted with our commissioning and programming tools, giving you the optimal solution to perform virtualization, planning, commissioning and maintenance.

Safe configuration for unpowered drives

The CCA-01 cold configuration adapter provides a serial communication interface for unpowered ACS580 drives. With the adapter, safety isolation of both serial communication and control board power supply is possible. The power supply is taken from a PC USB port.

Cold configurator



Users can download the software and parameters to drives without powering the drive.

MRP code	Description	Type designation
3AXD50000019865	Cold configurator adapter, packed kit	CCA-01

Drive Composer

The Drive Composer PC tool offers fast and harmonized setup, commissioning and monitoring for all-compatible drives. The free version of the tool provides startup and maintenance capabilities and gathers all drive information, such as parameter loggers, faults, backups and lists, into a support diagnostics file. Drive Composer pro provides additional features such as custom parameter windows, graphical control diagrams of the drive's configuration, and improved monitoring and diagnostics.

Drive Composer



Entry level (free)	Pro level
Basic functionality	Entry-level features
Parameter setting	Networked drives
Point-to-point connection	Control diagrams
Simple monitoring	Data logger(s)
Supports adaptive programming	Graphical safety setup
Adaptive programming in Demo mode	Adaptive (block) programming
–	Multiple backup and restore
–	Drive configuration by using virtual drive

Link/MRP codes	Description	Type designation
new.abb.com/drives/software-tools/drive-composer	Link to download free Drive Composer entry	–
9AKK105408A3415	Drive Composer entry PC tool (document)	–
3AUA0000108087	Drive Composer pro PC tool (single user license)	DCPT-01
3AUA0000145150	Drive Composer pro PC tool (10 users license)	DCPT-01
3AUA0000145151	Drive Composer pro PC tool (20 users license)	DCPT-01

Automation Builder

ABB Automation Builder is the integrated software suite for machine builders and system integrators wanting to automate their machines and systems in a productive way. Combining the tools required for configuring, programming, debugging and maintaining automation projects in a common, intuitive interface, Automation Builder addresses the largest single cost element of most of today's industrial automation projects: software.

Automation Builder



ABB Automation Builder covers the engineering of ABB PLCs, safety PLCs, control panels, drives, motion and robots.

The common engineering tool Automation Builder is used for drive and PLC programming and configuration.

Automation Builder is available in Basic, Standard and Premium editions, fitting the needs of small projects and managing the challenges of many and large projects for OEM and system integrators.

Adaptive programming

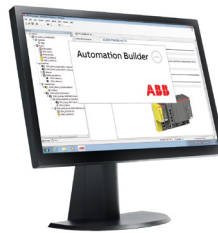
Adaptive programming software, embedded inside the drive, is especially handy when there is a need to distribute some of the machine's control logic to the drive. Adaptive programming brings energy savings when the drive is adjusted to control the application optimally. You can use our Drive Composer PC tool to set up the adaptive programming. The drive also offers sequence programming capabilities. Adaptive programming makes it possible to enhance the existing application control program to precisely fit users' application needs. The program is also handy for ensuring that the drive's electrical design is connected as it should be with working drive signals.

Adaptive programming

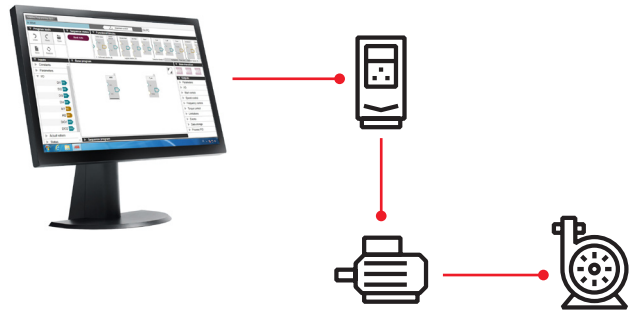

Drive manager

Drive Manager for SIMATIC (DM4S-01) is a plug-in device tool that can be easily installed, for example, in the STEP 7 and TIA Portal. It utilizes the TCI interface of the SIMATIC PLC to communicate with drives connected to PROFIBUS or a PROFINET network.

Drive Manager for SIMATIC offers several useful, ready-made features that simplify the setup of ABB low voltage drives used in combination, for example, with SIMATIC S7 PLCs including: Network connection over PROFIBUS and PROFINET (single point of access) Online and offline configuration of drives Monitoring of actual drive values Export to/import from the drive-dedicated PC tools Saving drive parameter settings within the SIMATIC PLC project

Drive manager

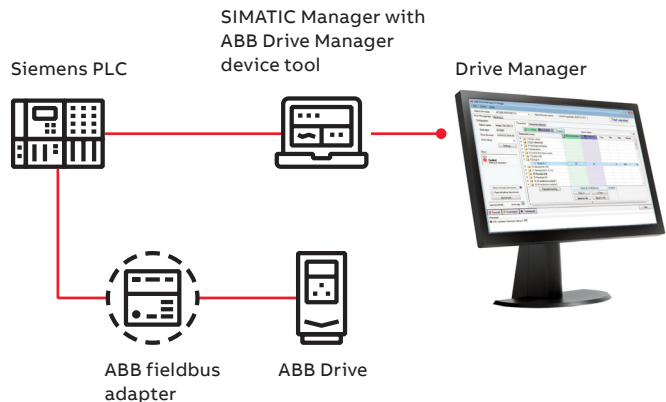

Communication and connectivity

Options

Fieldbus adapter modules

The ACS580 comes with Modbus RTU fieldbus interface as standard, and it is also compatible with a wide range of additional fieldbus protocols. Fieldbus communication reduces wiring costs compared to traditional hardwired input/output connections.

The fieldbus options can be installed into a slot one (1).

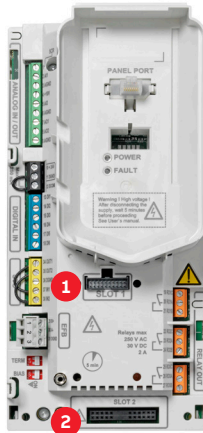

Input/output extension modules

Standard input and output can be extended by using optional analog and digital input/output extension modules. The modules are easily installed in the extension slot two (2) located on the drive.

Fieldbus options

Plus code	Fieldbus protocol	Adapter
+K451	DeviceNet™	FDNA-01
+K454	PROFIBUS DP, DPV0/DPV1	FPBA-01
+K457	CANopen®	FCAN-01
+K458	Modbus RTU	FSCA-01
+K462	ControlNet	FCNA-01
+K469	EtherCAT®	FECA-01
+K470	POWERLINK	FEPL-02
+K475	Two port EtherNet/IP™, Modbus TCP, PROFINET IO	FENA-21
+K490	Two port Ethernet/IP	FEIP-21
+K491	Two port Modbus/TCP	FMBT-21
+K492	Two port PROFINET IO	FPNO-21
+Q986	Safety functions fieldbus Profisafe module	FSPS-21



CMOD-01



CMOD-02



CBAI-01



CHDI-01



CPTC-02



CAIO-01

Options

Plus code	Description	Type designation
+L501	External 24 V AC and DC 2 x RO and 1 x DO	CMOD-01
+L523	External 24 V and isolated PTC interface	CMOD-02
+L512	115/230 V digital input 6 x DI and 2 x RO	CHDI-01
+L537+Q971	ATEX-certified PTC interface, Ex II (2) GD and external 24 V and ATEX certified safe disconnect function using STO *)	CPTC-02
+L500	Bipolar analog I/O adapter module **)	CBAI-01
+L525	Analog signal extension 3 x AI and 2 x AO	CAIO-01

*) For further information please see pages 48-49

**) Converts native analog inputs from unipolar to bipolar

Embedded fieldbus interface

Fieldbus protocol	Features	Connector type	+Code/ MRP code/ Typecode
 Modbus (RTU)	<ul style="list-style-type: none"> The embedded interface acts as a Modbus/RTU server with support for ABB drives profiles 	Screw terminal	As standard

The F-series fieldbus adapter modules

Fieldbus protocols	Features	Connector type	+Code/ MRP code/ Typecode
 EtherNet/IP	<ul style="list-style-type: none"> The interface module acts as an EtherNet/IP™ server with support for ODVA AC/DC drive and ABB drive profiles Supports both explicit messaging where each attribute of a class is set individually, and implicit messaging using input and output instances Support device-level ring (DLR) Has 2 RJ45 connections with an integrated switch Has Add-On Instructions available 	2 x RJ45	+K490 3AXD50000192786 (FEIP-21)
 PROFINET	<ul style="list-style-type: none"> PROFINET® IO is an open standard for Industrial Ethernet Used from process automation to motion control, as well as for functional-safety solutions Supports PROFIdrive and ABB drive profiles Has 2 RJ45 connections with an integrated switch S2 System redundancy Supports ring topology with Media Redundancy Protocol (MRP) Supports PROFIsafe with optional FSO-12/21 for ACS880 and with optional FSPS-21 for ACS380, ACS580 and ACS880 	2 x RJ45	+K492 3AXD50000192779 (FPNO-21)
 EtherCAT	<ul style="list-style-type: none"> EtherCAT® is a real-time Ethernet master/slave fieldbus system The EtherCAT slave devices read the data addressed to them while the telegram passes through the device enabling fast real-time communication The telegrams are only delayed by a few nanoseconds Supports CiA 402 and ABB drives profiles 	2 x RJ45	+K469 3AUA0000072069 (FECA-01)
 CANopen	<ul style="list-style-type: none"> CANopen® is a popular industrial communication network originally designed for motion-oriented machine control networks, such as handling systems Supports both cyclic and acyclic event driven communication. This makes it possible to reduce the bus load to a minimum and maintain short reaction times. Supports CiA 402 and ABB drive profiles 	Screw terminal D-SUB 9	+K495 (BCAN-11) 3AXD50000033816 +K457 68469376 (FCAN-01)
 ETHERNET POWERLINK	<ul style="list-style-type: none"> Ethernet POWERLINK is a real-time protocol for standard Ethernet The protocol guarantees transfer of time-critical data in very short cycles with configurable response time Supports CiA 402 and ABB drives profiles 	2 x RJ45	+K470 3AUA0000072120 (FEPL-02)
 ControlNet	<ul style="list-style-type: none"> ControlNet™ is an open control network that meets the demands of real-time, high-throughput applications Supports controller-to-controller interlocking and real-time control of I/O, drives and valves Provides control networking in discrete and process applications including high-availability Supports ODVA AC/DC Drive and ABB drives profiles Has add-On Instructions available 	2 x 8P8C	+K462 3AUA0000094512 (FCNA-01)
 DeviceNet	<ul style="list-style-type: none"> DeviceNet™ offers robust, efficient data handling since it is based on a Produce/Consume model Uses CAN (Controller Area Network) as the backbone technology and defines an application layer to cover a range of device profiles Supports ODVA AC/DC drive and ABB drives profiles 	Screw terminal	+K451 68469341 (FDNA-01)
 Modbus (TCP)	<ul style="list-style-type: none"> The interface module acts as a Modbus® TCP server with support for ABB drive profiles Common read/write single and multiple register function codes are supported Has 2 RJ45 connections with an integrated switch 	2 x RJ45	+K491 3AXD50000049964 (FMBT-21)
 PROFIBUS	<ul style="list-style-type: none"> PROFIBUS® DP is the most widely used industrial network ABB drives support PROFIBUS DP-V0 and DP-V1 Supports PROFIdrive and ABB drives profiles 	Screw terminal	+K458 3AUA0000031336 (FSCA-01)
 PROFIBUS	<ul style="list-style-type: none"> PROFIBUS® DP is the most widely used industrial network ABB drives support PROFIBUS DP-V0 and DP-V1 Supports PROFIdrive and ABB drives profiles 	D-SUB 9	+K454 68469325 (FPBA-01)

Safety options

Integrated safety

Integrated safety reduces the need for external safety components, simplifying configuration and reducing installation space. The safety functionality is a built-in feature of the ACS580, with safe torque off (STO) as standard. ACS580 can also be part of PROFIsafe over PROFINET network, where safety PLC is controlling the STO or safe stop 1, time controlled, SS1-t functionality. This connectivity and functionality can be done by using the FSPS-21 option module.

The drive's functional safety is designed in accordance with EN/IEC 61800-5-2 and complies with the requirements of the European Union Machinery Directive (2006/42/EC). The safety functions are certified by TÜV Nord and comply with the highest safety performance level (SIL 3/PL e) for machinery safety. It is possible to install the safety modules also afterwards to the drive.

PROFIsafe safety functions module FSPS-21

The FSPS-21 module has integrated PROFIsafe, safety functions and PROFINET IO connection. The ready-made safety functions make safety configuration in the drive unnecessary. The module supports STO and SS1-t safety functions. It is used together with a safety PLC that supports PROFIsafe over PROFINET communication.

For more information see FSPS-21 PROFIsafe safety functions module web page at new.abb.com/drives/functional-safety



Safe torque off (STO)

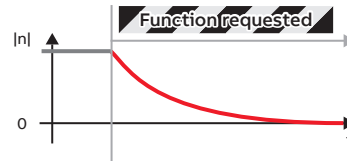

STO is the basic foundation of drive-based functional safety, as it brings a drive safely to no-torque state making the motor coast to stop. Integrated STO-function simplifies the safety circuit as external components are not needed to safely stop the application.

- **STO** is a standard safety function in all ABB drives.
- Typically used for prevention of an unexpected startup (EN ISO 14118) of machinery or for an emergency stop, fulfilling stop category 0 (EN 13850 / IEC 60204-1).

Safe stop 1, time controlled (SS1-t)

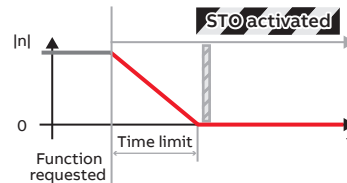

Safe stop 1 stops the motor safely with a controlled ramp stop and stop time monitoring. SS1-t initiates the ramp stop from the drive and activates STO when speed reaches zero. If the drive is not decelerating to zero speed within the time limit, the STO function is activated. SS1-t is typically used in applications where motion must be stopped quickly and safely before switching to a no-torque state.

- **SS1-t** stops the motor safely, using a controlled ramp stop and then activates the STO function.
- **SS1-t** can be used to implement an Emergency stop, fulfilling stop category 1 (EN/IEC 60204-1).



PROFIsafe safety functions module FSPS-21

Option code	Ordering code	Module
+Q986	3AXD50000112821	FSPS-21

Note: This module isn't compatible with other fieldbus option modules for ACS380 and ACS580 drives

Example: SS1-t

Safety function module FSPS-21, functionality cycle

0. Drive running

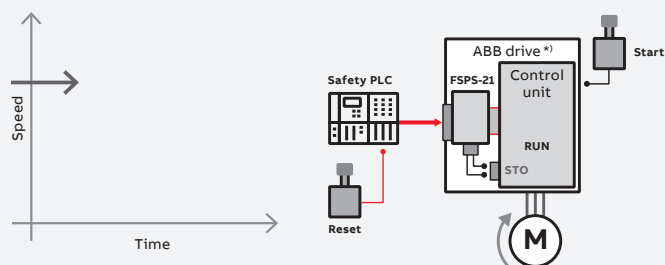

1. Safety PLC – safety function request to the FSPS-21

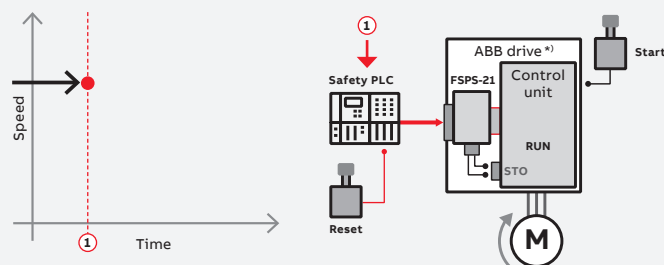

2. SS1-t, safety functions request / start of monitoring

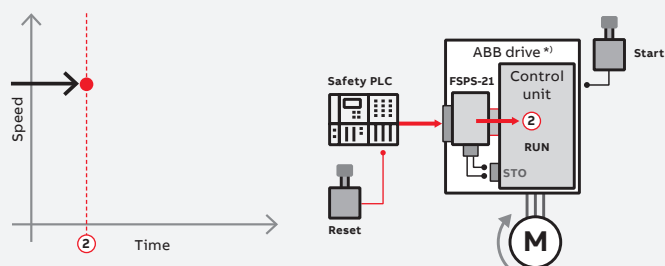

3. Transition and time monitoring of the SS1-t

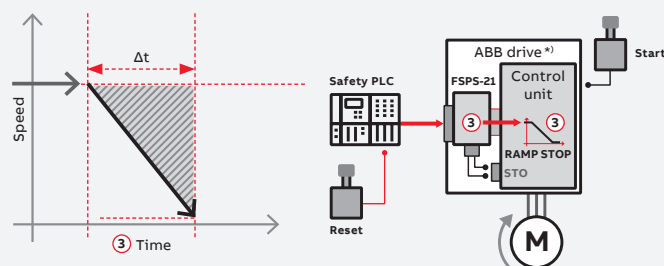

4. Zero speed or SS1-t time limit reached / STO is opened

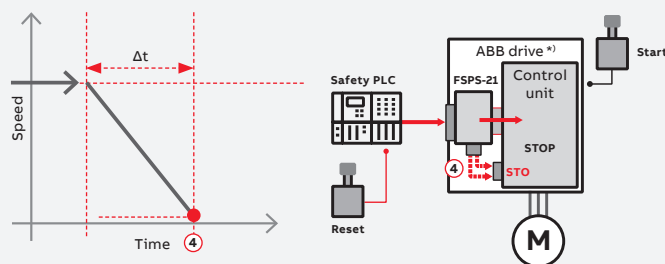

5. Safe state / STO is open

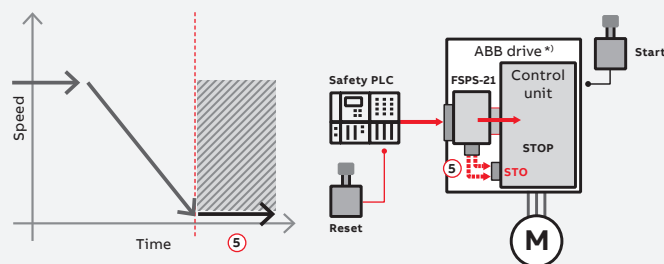

6. Safety function request removed / reset / STO is closed

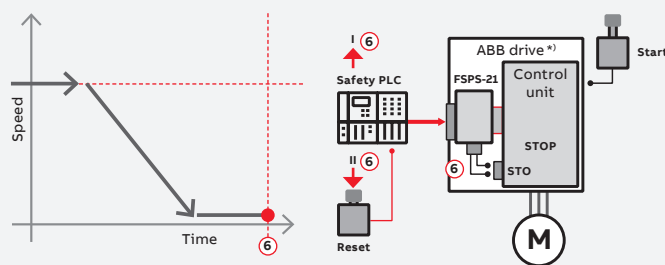

7. Start – return to normal operation

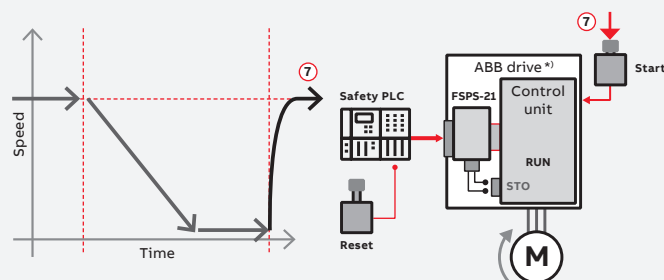

^{*)} The ABB drive can be ACS380, ACS580 or ACS880

ABB Ability™ Digital Powertrain

Condition monitoring for drives



Accurate, real-time information about powertrain events. When you have the facts, you can make the right decisions.

Condition Monitoring gives you fact-based insight into your powertrain assets, such as drives and motors, via KPIs and signal data, to identify irregularities before they become problems. This helps you make proactive decisions, built on real-time information – and saves you money!

The service can be tailored to fit your needs

Our standard package gives you industry leading monitoring capabilities – whether you want to view the drive status through ABB's Internet portal or integrate this data with your existing monitoring systems.

The standard package includes the following services:

- Condition Monitoring
- Alarm Management
- Asset Health
- Team Support
- Backup Management

The standard package can be supplemented with optional services:

- Offline Data Collection
- Expert Reports
- Remote Assistance
- Condition monitoring of your entire powertrain



Solid fact-based decision making

Get the facts, and the history, to help run your operations better and more safely.



Always stay one step ahead of problems

Recognize early signs of possible failures and assess the risks, before they turn into serious operational issues.



Find the root cause of process issues

Remotely access data from ABB drives built-in sensors to track the cause of problems. Get back to smooth operation quickly with data back-ups.



Remotely analyze and optimize drives

Get critical drive information anywhere anytime – even in difficult to access sites, or when a site visit is impossible.

NETA-21

NETA-21 connects the drive to the cloud via the Internet or local Ethernet network.

- The module comes with a built-in web server and requires no Flash/Java plugins
- In the absence of a customer local area network, it can be connected via a mobile network router (either Ethernet or USB network adapter)
- One module can be connected to several drives at the same time

NETA-21	Ordering code	Description
	3AUA0000094517	2 x panel bus interface
		max. 9 drives
		2 x Ethernet interface
		SD memory card

RMDE reliability monitoring device

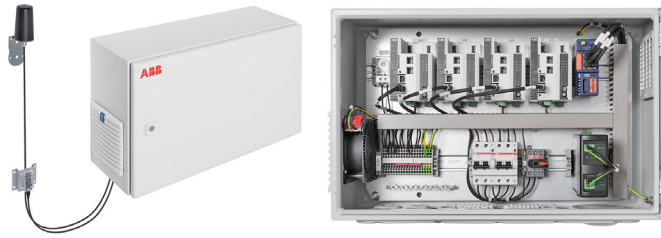

The RMDE reliability monitoring device facilitates the installation of the connectivity device (NETA-21) on drives that are already installed.

- The RMDE device can contain two or four NETA modules and can connect up to 18 or even 36 drives
- The cabinet consists of the NETA-21 connectivity devices, a modem and environmental sensors that enable the collection of measured ambient temperature and humidity values
- The cabinet includes a compact IP54 enclosure, making it suitable even for dusty environments

Customers can configure powertrains and customize the digital service plan

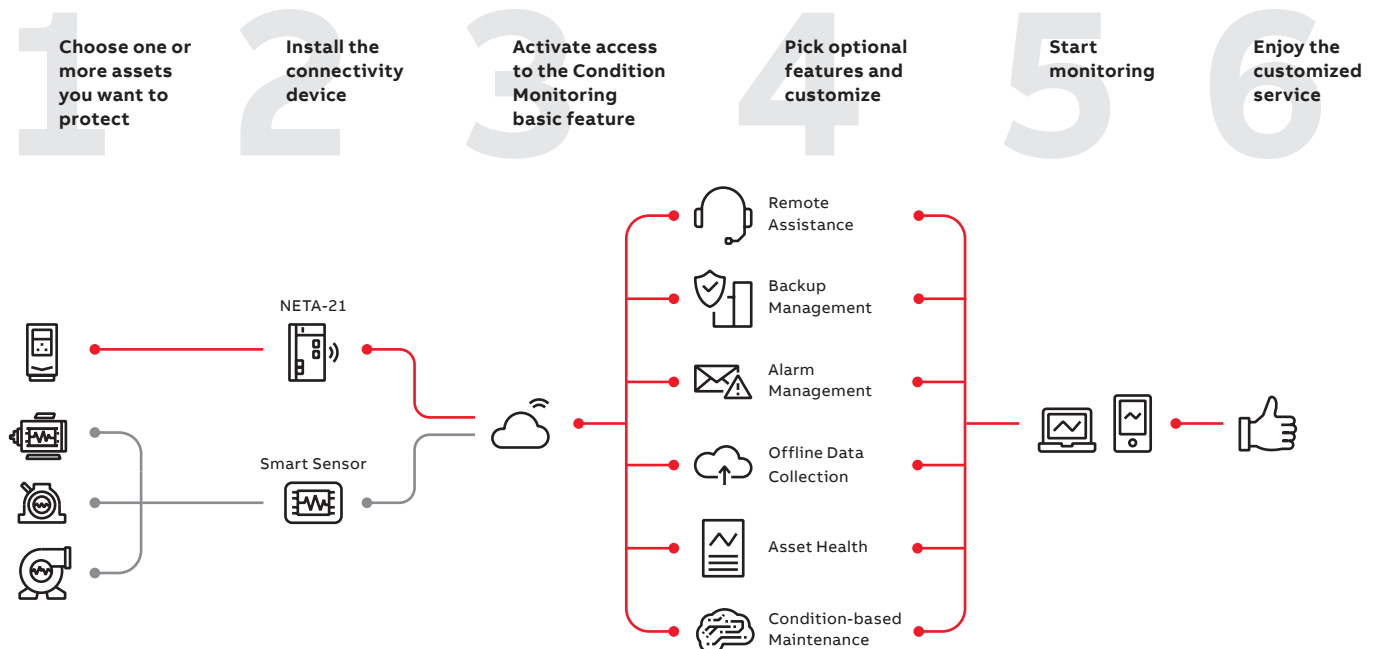

EMC – electromagnetic compatibility

What is EMC?

EMC stands for electromagnetic compatibility. It is the ability of electrical/electronic equipment to operate without problems in an electromagnetic environment .

Likewise, the equipment must not disturb or interfere with any other product or system in its locality. This is a legal requirement for all equipment taken into service within the European Economic Area (EEA).

Installation environments

A power drive system (PDS) can be connected to either industrial or public power distribution networks .

The environment class depends on the way the PDS is connected to power supply .

The **1st environment** includes domestic premises. It also includes establishments directly connected without an intermediate transformer to a low voltage power supply network that supplies buildings used for domestic purposes.

The **2nd environment** includes all establishments directly connected to public low voltage power supply networks.

EMC solutions

To fulfill the EMC requirements, the drives are equipped with standard or optional RFI filtering for HF disturbances.

- Using ferrite rings in power connection points
- Using an AC or DC choke (while they are meant to protect against harmonics, they reduce HF disturbances as well)
- Using an LCL filter in the case of regenerative drives
- Using a du/dt filter

Immunity and emission compatibility

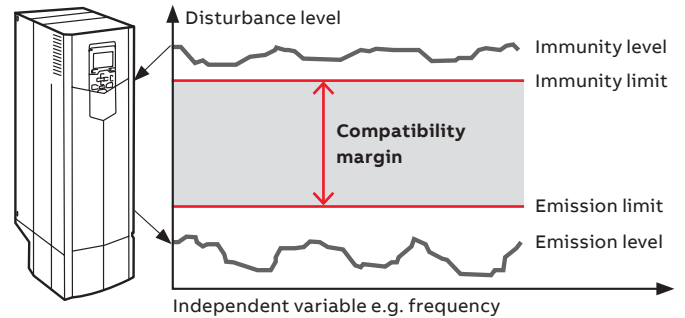

Installation environments

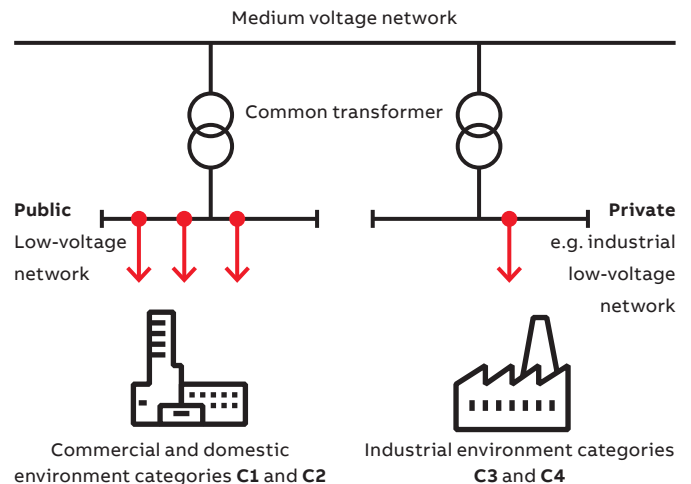

The product standard EN 61800-3 divides PDSs into four categories according to the intended use

C1 – 1st environment

- Household appliances
- Usually plug connectible to any wall outlet
- Anyone can connect these to the network
- Examples: washing machines, TV sets, computers, microwave ovens, etc.

C2 – 1st environment

- Fixed household and public appliances
- Need to be installed or operated by a professional
- Examples: elevators, rooftop fans, residential booster pumps, gates and barriers, supermarket freezers, etc.

C3 – 2nd environment

- Professional equipment
- Needs to be installed or operated by a professional
- In some rare cases, may also be pluggable
- Examples: any equipment for industrial usage only, such as conveyors, mixers, etc.

C4 – 2nd environment

- Professional equipment
- Needs to be fixed installation and operated by a professional
- Examples: paper machines, rolling mills, etc.

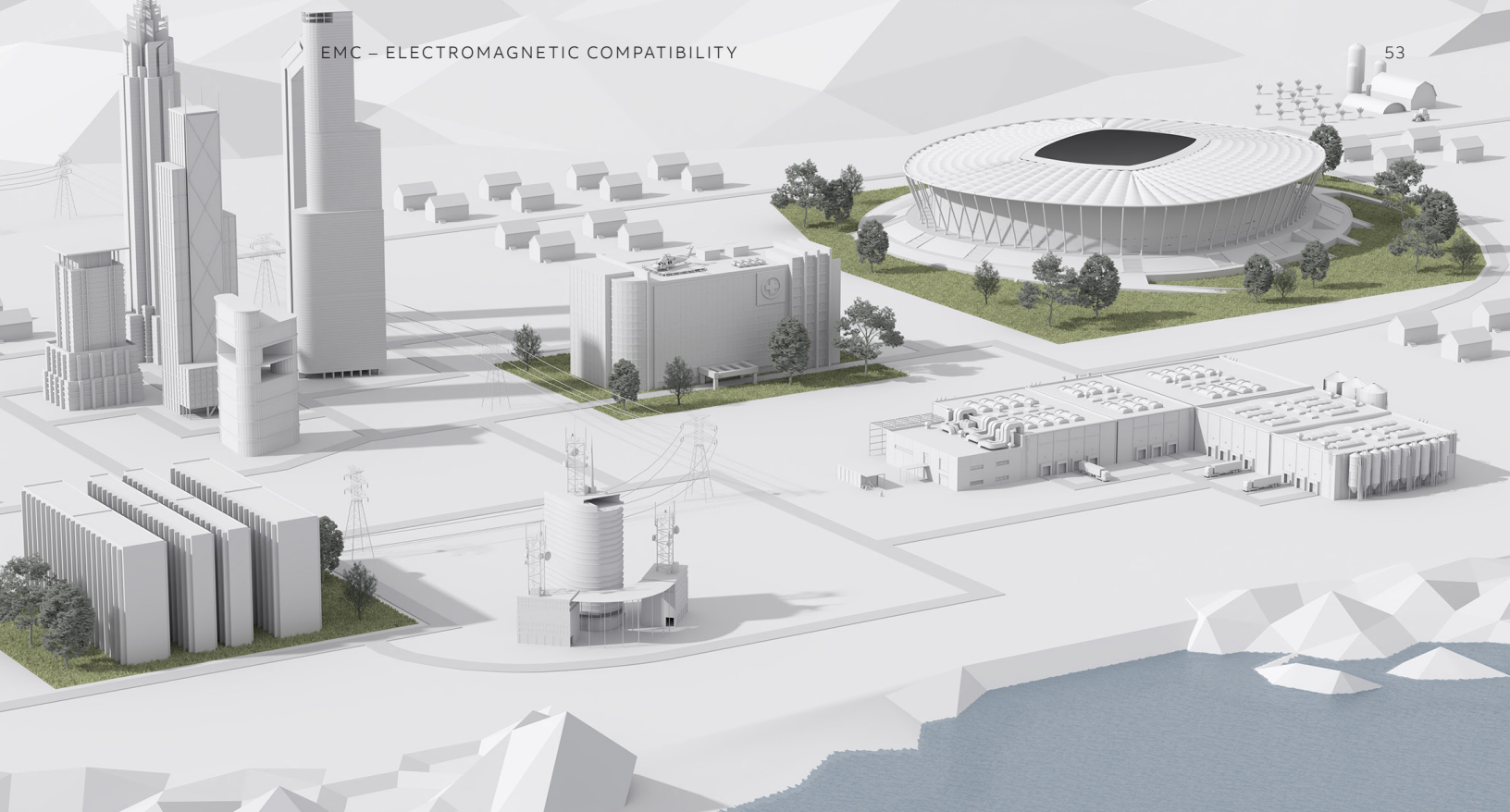

Every ACS580 drive is equipped with a built-in filter to reduce high-frequency emissions.

EMC product standard (EN 61800-3) category C2 is fulfilled in wall-mounted drives and in cabinet-built drives up to frame size R9. Category C3 is fulfilled in drive modules and cabinet-built drives (frames R10 and R11) with no external filters.

Comparison of EMC standards

EN 61800-3, product standard	EN 61800-3, product standard	EN 55011, product family standard for industrial, scientific and medical (ISM) equipment	EN 6100-6-4, generic emission standard for industrial environments	EN 61000-6-3, generic emission standard for residential, commercial and light-industrial environments
Category C1	1 st environment, unrestricted distribution	Group 1. Class B	Not applicable	Applicable
Category C2	1 st environment, restricted distribution	Group 1. Class A	Applicable	Not applicable
Category C3	2 nd environment, unrestricted distribution	Group 2. Class A	Not applicable	Not applicable
Category C4	2 nd environment, restricted distribution	Not applicable	Not applicable	Not applicable

EMC compliance and maximum cable length of ACS580-01/07 units^{*)}

Type	Voltage	Frame sizes	1 st environment, restricted distribution, C1, grounded network (TN)	1 st environment, restricted distribution, C2, grounded network (TN)	2 nd environment, unrestricted distribution, C3, grounded network (TN)	2 nd environment, unrestricted distribution, C3, ungrounded network (IT)
ACS580-01	380-480 V	R1-R5	With the plus codes: +F316, +E223	Standard device, cable length 100 m	Standard device, cable length 100 m	–
ACS580-01/07	380-480 V	R6-R9	–	Standard device, cable length 150 m	Standard device, cable length 150 m	–
ACS580-04/07	380-480 V	R10-R11	–	–	Standard device, cable length 100 m	–

^{*)} Motor cable operational functionality up to 300 m. See ACS580 hardware manuals 3AXD50000018826, 3AXD50000015497, 3AXD50000045815 and 3AXD50000032622 for frame specific information.

Harmonic mitigation

What are harmonics?

Harmonic currents are created by non-linear loads connected to the power distribution system. Harmonic distortion is a form of pollution in the electric plant that can cause problems if the voltage distribution caused by harmonic currents increases above certain limits.

All power electronic converters used in different types of electronic systems can increase harmonic disturbances by injecting harmonic currents directly into the grid.

Electricity supply is hardly ever a pure sine wave voltage, and current that deviates from the sine form contains harmonics. The distortion is caused by non-linear loads connected to the electrical supply. Harmonics cause disturbances and equipment failures.

The total current as the sum of the fundamental and 5th harmonics

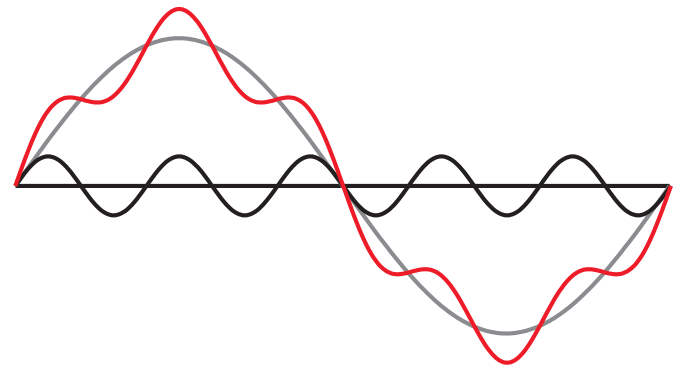

— Fundamental signal = $\sin(x)$
 — Periodic signal (x) = Fundamental + 5th = $\sin(x) + 0.2\sin(5x)$
 — 5th harmonic = $0.2\sin(5x)$

Where do the harmonics come from?

Non-linear loads such as:

- Variable speed drives
- Uninterrupted power supplies (UPS)
- Industrial rectifiers
- Welding machines
- Fluorescent lighting systems (electronic ballast)
- Computers
- Printers
- Servers
- Electronic appliances

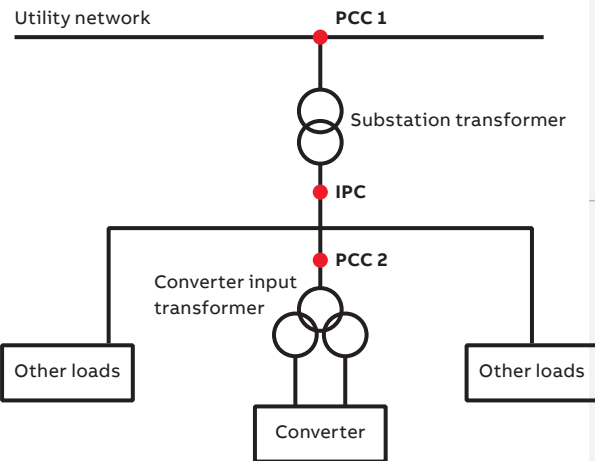

- Point of common coupling (**PCC**) is the point where the harmonic distortion is specified, e.g.
 - Between the plant and the utility network (**PCC1**)
 - Between the non-linear load and other loads within an industrial plant (**PCC 2**)

- In-plant point of coupling (**IPC**) is the point inside the customer system or installation to be studied

The effects of harmonic distortions

Harmonic currents

- Mainly affect the power distribution system up to the rectifier:
- Additional losses in wires and cables
 - Extra heating of transformers
 - Circuit breaker malfunctioning

Harmonic voltage

- Can affect other equipment connected to the electrical system:
- Erratic operation of telecommunication systems, computers, video monitors, electronic test equipment, etc.
 - Resonance with power factor correction capacitors

ACS580 drives are compliant with EN 61000-3-12. They are equipped with:

- Optimized DC choke (R1-R9)
- AC chokes (R10-R11)

By choosing the ACS580, you can automatically make your plant more reliable. Built-in chokes mitigate harmonics reducing disturbances and equipment failures. Smaller harmonic content also saves money and makes the installation easier because it allows smaller fuses and longer motor cables to be used. Less harmonics also means longer lifetime for the components and thus less maintenance needs and downtime.



Reliable operation



Reduced cost



Longer lifetime

Drive system features affecting harmonics

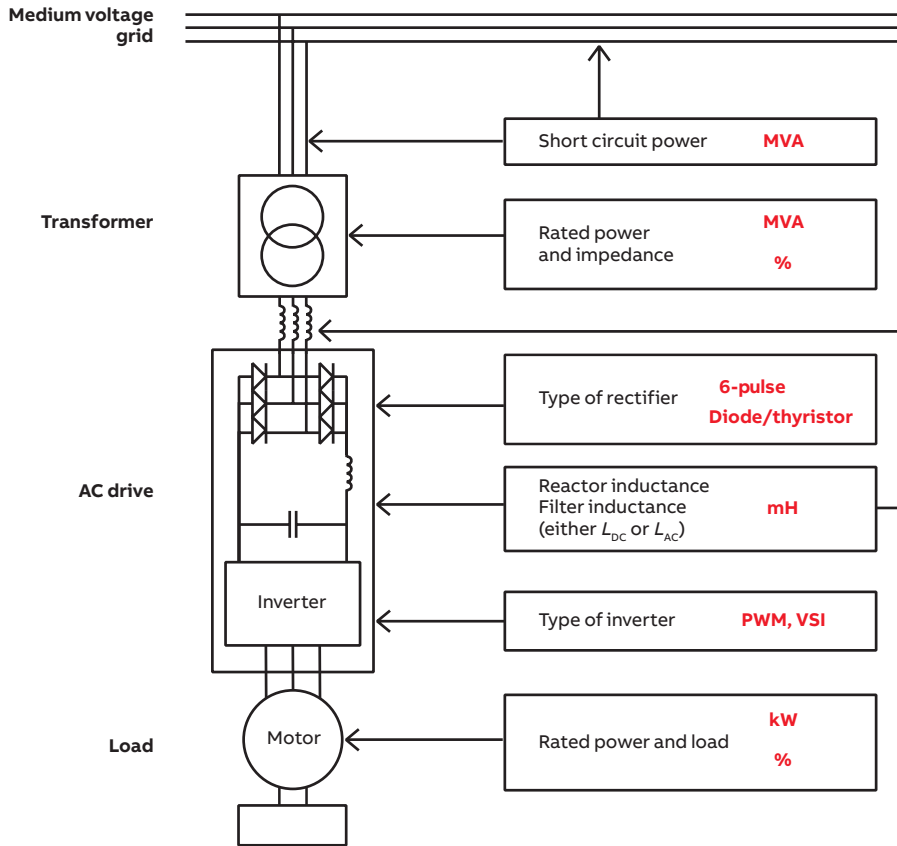

Harmonics reduction can be achieved either by structural modifications in the drive system or by using external filtering. The structural modifications may be to strengthen the supply, or to use 12 or more pulse drives, to use a controlled rectifier, or to improve the internal filtering in the drive .

The image to the left shows the factors in the AC drive system that have some influence on harmonics. The current harmonics depend on the drive construction, and the voltage harmonics are the current harmonics multiplied by the supply impedances.

Tested packages



Motor and drive combinations are **tested and certified in ABB's test center**. By using an ABB motor together with an ABB drive as a package, you can enjoy the benefits of efficient, high-performance motors with optimal speed and control accuracy – without compromising on safety.

With the ABB ATEX certified motor and drive package the ATEX certified temperature protection modules are not obligatory, the tested combinations fulfill the IEC/ATEX standards and ensure safe performance.

- No additional testing and certification are needed
- No ATEX thermistor protection modules are needed
- Safe and cost effective solution for industries in potentially explosive atmospheres

Safe temperature monitoring



For non-tested and certified motors and drives (e.g. for use with other manufacturer's motors), ATEX certified temperature protection is an integrated option.

The ACS580's ATEX-certified thermistor protection module, Ex II (2) GD, CPTC-02, can be integrated into the drive if the motor is operating in a potentially explosive environment. **The purpose of the safety function is to disconnect the motor from the power supply before the motor overheats and causes a risk of explosion in an ATEX environment.**

Correct dimensioning

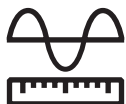

Correct dimensioning is important. **Correctly sized motors and drives reduce motor frame heating and sparks from bearing currents.** They also help to reduce energy use.

Insulation and drive filters



ABB's offering for correct insulation and filters **protects the motor** from voltage phenomena, bearing currents and motor overheating. The insulation and filters must be selected according to voltage and frame size.

Easy drive upgrades



With the drive upgrades below, the ATEX certification stays valid from the old to the new generation models. This means that there is no need for new ATEX certification during the upgrade. This saves you time and money.

ATEX certification approved – old generation model	Comparable converter upgrade	ATEX certification stays valid – new generation model
ACS550	→	ACS580

Global service and support network



ABB's global network of certified service providers are trained and experienced to help you with motors and drives for applications in explosive atmospheres.

The support network ensures that your ABB Declaration of Conformity is retained.

ABB's ATEX-certified thermistor protection module, Ex II (2) GD, CPTC-02

With option +L537 +Q971:

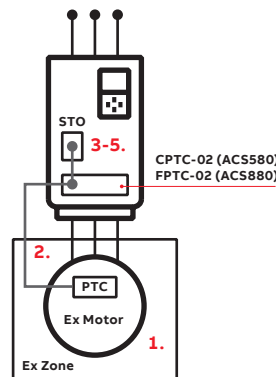

1. Motor temperature rises above the PTC sensor limit temperature.
2. The sensor resistance increases very sharply and indicates overheating to the ATEX-certified module, Ex II (2) GD.
3. The module switches the STO (Safe Torque Off) circuit off, which activates the STO function.
4. The STO function disables the control voltage in the power semiconductors of the drive output stage.
5. The drive is prevented from generating the required torque to rotate the motor.

▶ **The safe state is guaranteed**

Note:

The CPTC-02 module can be managed as a loose option and can also be retrofitted to the drive; in this case, to be compliant with regulations, the customer must ensure the following requirements:

- That the serial number of the drive/inverter module starts with 1, 4, 7, 8 or Y
- That the drive and option serial number is paired in a DIB (Drive Installed Base) portal
- That the included ATEX label for the SMT (Safe Motor Temperature) function is attached to the drive/inverter module to ensure the ATEX compliance of the safety circuit
- That the option module is installed in an option slot of the drive control unit and the applicable drive parameters are set
- That the PTC temperature sensors of the motor are connected to the PTC inputs of the option module.

* For further information please contact local ABB

ABB's ATEX-certified thermistor protection module

Option code	Ordering code	
+L537	3AXD50000033578	CPTC-02 ATEX-certified PTC interface, Ex II (2) GD and external 24 V (requires also option +Q971)
+Q971	-	ATEX-certified Safe Disconnection Function, Ex II (2) GD

Cooling and fuses

Cooling

ACS580 drives are fitted with variable-speed cooling air fans. The cooling air must be free from corrosive materials and not exceed the maximum ambient temperature of 40 °C for frames R1 to R9 (50 °C with derating). The speed-controlled fans cool the drive only when needed, which reduces overall noise level and energy consumption.

Fuse connections

Standard fuses can be used with ABB general purpose drives. For input fuses, see the table below.

Note: For UL Type 4X (IP66) drives that include the disconnect and fuse option, no branch circuit protection is required external to the drive. The Type JJS fuses shown in the tables below are included inside the drive.

Wall-mounted drives, ACS580-01 460 V

Cooling air flow and recommended input protection fuses for 440 to 480 V units

Type designation	Frame size	Cooling Air Flow 440 to 480 V units					Recommended UL Input Protection fuses			UL class
		Heat dissipation*		Air flow		Max. noise level**	I _N	Voltage rating	Bussmann type***	
		W	BTU/Hr	m3/h	ft3/min					
ACS580-01-02A1-4	R1	37	126	43	25	59	15	600	KTK-R-15, JSK-15, DFJ-15, FCF15RN or JJS-15	CC, CF, J or T
ACS580-01-03A0-4	R1	47	160	43	25	59	15	600	KTK-R-15, JSK-15, DFJ-15, FCF15RN or JJS-15	CC, CF, J or T
ACS580-01-03A5-4	R1	52	177	43	25	59	15	600	KTK-R-15, JSK-15, DFJ-15, FCF15RN or JJS-15	CC, CF, J or T
ACS580-01-04A8-4	R1	71	242	43	25	59	15	600	KTK-R-15, JSK-15, DFJ-15, FCF15RN or JJS-15	CC, CF, J or T
ACS580-01-07A6-4	R1	103	351	43	25	59	15	600	KTK-R-15, JSK-15, DFJ-15, FCF15RN or JJS-15	CC, CF, J or T
ACS580-01-012A-4	R1	200	682	43	25	59	15	600	KTK-R-15, JSK-15, DFJ-15, FCF15RN or JJS-15	CC, CF, J or T
ACS580-01-014A-4	R2	238	812	101	59	64	30	600	KTK-R-30, JKS-30, DFJ-30, FCF30RN or JJS-30	CC, CF, J or T
ACS580-01-023A-4	R2	342	1167	101	59	64	30	600	KTK-R-30, JKS-30, DFJ-30, FCF30RN or JJS-30	CC, CF, J or T
ACS580-01-027A-4	R3	386	1317	179	105	76	40	600	JKS-40, DFJ-40, FCF40RN or JJS-40	CF, J or T
ACS580-01-034A-4	R3	446	1522	179	105	76	60	600	JKS-60, DFJ-60, FCF60RN or JJS-60	CF, J or T
ACS580-01-044A-4	R3	656	2238	179	105	76	60	600	JKS-60, DFJ-60, FCF60RN or JJS-60	CF, J or T
ACS580-01-052A-4	R4	671	2290	134	79	69	80	600	JKS-80, DFJ-80, FCF80RN or JJS-80	CF, J or T
ACS580-01-052A-4	R4 v2	640	2184	150	88	70	80	600	JKS-80, DFJ-80, FCF80RN or JJS-80	CF, J or T
ACS580-01-065A-4	R4	719	2453	134	79	69	100	600	JKS-100, DFJ-100, FCF100RN or JJS-100	CF, J or T
ACS580-01-065A-4	R4 v2	760	2593	150	88	70	100	600	JKS-100, DFJ-100, FCF100RN or JJS-100	CF, J or T
ACS580-01-077A-4	R4 v2	1047	3573	159	94	70	100	600	JKS-100, DFJ-100 or JJS-100	J or T
ACS580-01-078A-4	R5	941	3211	139	82	63	110	600	JKS-110, DFJ-110 or JJS-110	J or T
ACS580-01-096A-4	R5	1127	3845	139	82	63	150	600	JKS-150, DFJ-150 or JJS-150	J or T
ACS580-01-124A-4	R6	1563	5333	435	256	67	200	600	JKS-200, DFJ-200 or JJS-200	J or T
ACS580-01-156A-4	R7	1815	6193	450	265	67	225	600	JKS-225, DFJ-225 or JJS-225	J or T
ACS580-01-180A-4	R7	2285	7797	450	265	67	300	600	JKS-300, DFJ-300 or JJS-300	J or T
ACS580-01-240A-4	R8	3039	10369	550	324	65	350	600	JKS-350, DFJ-350 or JJS-350	J or T
ACS580-01-260A-4	R8	3398	11594	550	324	65	400	600	JKS-400, DFJ-400 or JJS-400	J or T
ACS580-01-302A-4	R9	3253	11100	1150	677	68	500	600	JKS-500, DFJ-500 or JJS-500	J or T****
ACS580-01-361A-4	R9	4836	16501	1150	677	68	500	600	JKS-500, DFJ-500 or JJS-500	J or T****
ACS580-01-414A-4	R9	5691	19418	1150	677	68	600	600	JKS-600, DFJ-600 or JJS-600	J or T****

* Heat dissipation value is a reference for cabinet thermal design

** The maximum noise level is at full fan speed. When the drive is not operating at full load and at maximum ambient temperature the noise level is lower.

***ABB does not require Bussmann brand fuses. Fuses which meet the appropriate UL class type, current rating, and are rated at 600V, 200 kA may be used.

**** Most drives built in 2020 or earlier can only be protected with Class T (JJS) fuses. See 3AXD50000645015 Branch Circuit Protection for ABB Drives for additional information.

NOTE: For UL Type 4X (IP66) drives, when disconnect and fuse option is included (+B066+F254), add 8 W (27 BTU/h) for R1; 11 W (38 BTU/h) for R2; 24 W (82 BTU/h) for R3

Cooling and fuses

Wall-mounted drives, ACS580-01 230 V

Cooling air flow and recommended input protection fuses for 200 to 240 V units

Type designation	Frame size	Cooling Air Flow 200 to 240 V units					Recommended UL Input Protection fuses			UL class
		Heat dissipation*	Air flow		Max. noise level**	I _N	Voltage rating	Bussmann type***		
			W	BTU/Hr					m3/h	
ACS580-01-04A6-2	R1	50	171	43	25	59	15	600	KTK-R-15, JKS-15, DFJ-15, FCF15RN or JJS-15	CC, CF, J or T
ACS580-01-06A6-2	R1	69	235	43	25	59	15	600	KTK-R-15, JKS-15, DFJ-15, FCF15RN or JJS-15	CC, CF, J or T
ACS580-01-07A5-2	R1	79	270	43	25	59	15	600	KTK-R-15, JKS-15, DFJ-15, FCF15RN or JJS-15	CC, CF, J or T
ACS580-01-10A6-2	R1	120	409	43	25	59	15	600	KTK-R-15, JKS-15, DFJ-15, FCF15RN or JJS-15	CC, CF, J or T
ACS580-01-017A-2	R1	203	693	43	25	59	30	600	KTK-R-30, JKS-30, DFJ-30, FCF30RN or JJS-30	CC, CF, J or T
ACS580-01-024A-2	R2	247	843	101	59	64	40	600	JSK-40, DFJ-40, FCF40RN or JJS-40	CF, J or T
ACS580-01-031A-2	R2	348	1187	101	59	64	40	600	JSK-40, DFJ-40, FCF40RN or JJS-40	CF, J or T
ACS580-01-046A-2	R3	518	1767	179	105	76	80	600	JSK-80, DFJ-80, FCF80RN or JJS-80	CF, J or T
ACS580-01-059A-2	R3	762	2600	179	105	76	80	600	JSK-80, DFJ-80, FCF80RN or JJS-80	CF, J or T
ACS580-01-075A-2	R4	809	2760	288	170	69	100	600	JSK-100, DFJ-100, FCF100RN or JJS-100	CF, J or T
ACS580-01-088A-2	R5	861	2938	139	82	63	150	600	JSK-150, DFJ-150 or JJS-150	J or T
ACS580-01-114A-2	R5	1268	4327	139	82	63	150	600	JSK-150, DFJ-150 or JJS-150	J or T
ACS580-01-143A-2	R6	1916	6538	435	256	67	200	600	JKS-200, DFJ-200 OT JJS-200	J or T
ACS580-01-169A-2	R7	1965	6705	450	265	67	250	600	JKS-250, DFJ-250 OT JJS-250	J or T
ACS580-01-211A-2	R7	2809	9585	450	265	67	300	600	JKS-300, DFJ-300 OT JJS-300	J or T
ACS580-01-273A-2	R8	3518	12004	550	324	65	400	600	JKS-400, DFJ-300 OT JJS-400	J or T
ACS580-01-343A-2	R9	2547	8691	1150	677	68	500	600	JKS-500, DFJ-500 or JJS-500	J or T
ACS580-01-396A-2	R9	3060	10441	1150	677	68	600	600	JKS-600, DFJ-600 or JJS-600	J or T

* Heat dissipation value is a reference for cabinet thermal design

** The maximum noise level is at full fan speed. When the drive is not operating at full load and at maximum ambient temperature the noise level is lower.

***ABB does not require Bussmann brand fuses. Fuses which meet the appropriate UL class type, current rating, and are rated at 600V, 200 kA may be used.

NOTE: For UL Type 4X (IP66) drives, when disconnect and fuse option is included (+B066+F254), add 8 W (27 BTU/h) for R1; 11 W (38 BTU/h) for R2; 24 W (82 BTU/h) for R3

**** Most drives built in 2020 or earlier can only be protected with Class T (JJS) fuses. See 3AXD50000645015 Branch Circuit Protection for ABB Drives for additional information.

Wall-mounted drives, ACS580-01 600 V

Cooling air flow and recommended input protection fuses for 525 to 600 V units

Type designation	Frame size	Cooling Air Flow 525 to 600 V units					Recommended UL Input Protection fuses			UL class
		Heat dissipation*	Air flow		Max. noise level**	I _N	Voltage rating	Bussmann type***		
			W	BTU/Hr					m3/h	
ACS580-01-02A7-6	R2	66	225	101	59	64	15	600	KTK-R-15, JKS-15, DFJ-15, FCF15RN or JJS-15	CC, CF, J or T
ACS580-01-03A9-6	R2	84	287	101	59	64	15	600	KTK-R-15, JKS-15, DFJ-15, FCF15RN or JJS-15	CC, CF, J or T
ACS580-01-06A1-6	R2	133	454	101	59	64	15	600	KTK-R-15, JKS-15, DFJ-15, FCF15RN or JJS-15	CC, CF, J or T
ACS580-01-09A0-6	R2	174	594	101	59	64	15	600	KTK-R-15, JKS-15, DFJ-15, FCF15RN or JJS-15	CC, CF, J or T
ACS580-01-011A-6	R2	228	778	101	59	64	15	600	KTK-R-15, JKS-15, DFJ-15, FCF15RN or JJS-15	CC, CF, J or T
ACS580-01-017A-6	R2	322	1099	101	59	64	30	600	KTK-R-30, JKS-30, DFJ-30, FCF30RN or JJS-30	CC, CF, J or T
ACS580-01-022A-6	R3	430	1467	179	105	75	40	600	JKS-40, DFJ-40, FCF40RN or JJS-40	CF, J or T
ACS580-01-027A-6	R3	524	1788	179	105	75	40	600	JKS-40, DFJ-40, FCF40RN or JJS-40	CF, J or T
ACS580-01-032A-6	R3	619	2112	179	105	75	40	600	JKS-40, DFJ-40, FCF40RN or JJS-40	CF, J or T
ACS580-01-041A-6	R5	835	2849	139	82	63	100	600	JKS-100, DFJ-100 or JJS-100	J or T
ACS580-01-052A-6	R5	1024	3494	139	82	63	100	600	JKS-100, DFJ-100 or JJS-100	J or T
ACS580-01-062A-6	R5	1240	4231	139	82	63	100	600	JKS-100, DFJ-100 or JJS-100	J or T
ACS580-01-077A-6	R5	1510	5152	139	82	63	100	600	JKS-100, DFJ-100 or JJS-100	J or T
ACS580-01-099A-6	R7	2061	7032	450	265	67	150	600	JKS-150, DFJ-150 or JJS-150	J or T
ACS580-01-125A-6	R7	2466	8414	450	265	67	200	600	JKS-200, DFJ-200 or JJS-200	J or T
ACS580-01-144A-6	R8	3006	10257	550	324	65	250	600	JKS-250, DFJ-250 or JJS-250	J or T
ACS580-01-192A-6	R9	4086	13942	1150	677	68	300	600	JKS-300, DFJ-300 or JJS-300	J or T
ACS580-01-242A-6	R9	4896	16706	1150	677	68	400	600	JKS-400, DFJ-400 or JJS-400	J or T
ACS580-01-271A-6	R9	4896	16706	1150	677	68	400	600	JKS-400, DFJ-400 or JJS-400	J or T

* Heat dissipation value is a reference for cabinet thermal design

** The maximum noise level is at full fan speed. When the drive is not operating at full load and at maximum ambient temperature the noise level is lower.

***ABB does not require Bussmann brand fuses. Fuses which meet the appropriate UL class type, current rating, and are rated at 600V, 200 kA may be used.

**** Most drives built in 2020 or earlier can only be protected with Class T (JJS) fuses. See 3AXD50000645015 Branch Circuit Protection for ABB Drives for additional information.

NOTE: For UL Type 4X (IP66) drives, when disconnect and fuse option is included (+B066+F254), add 8 W (27 BTU/h) for R1; 11 W (38 BTU/h) for R2; 24 W (82 BTU/h) for R3

Cooling and fuses

Cabinet-built drives, ACS580-07

Cooling air flow and input protection fuses for 200 to 240 V units

Type designation	Frame size	Cooling Air Flow 200 to 240 V units						UL Input Protection fuses			
		Heat dissipation*		Air flow		Max. noise level**	I _N	Voltage rating	Bussmann type***	UL class	
		W	BTU/Hr	m3/h	ft3/min						dBa
ACS580-07-0246A-4+B055+C129+H351+H353+H358	R8	3719	12690	700	412	65	246	690	170M5408	T	
ACS580-07-0363A-4+B055+C129+H351+H353+H358	R9	5321	18156	1300	765	68	363	690	170M6410	T	
ACS580-07-0430A-4+B055+C129+H351+H353+H358	R9	6589	22482	1300	765	68	430	690	170M6411	T	
ACS580-07-0505A-4+B055+C129+H351+H353+H358	R10	7102	24233	1900	1118	72	505	690	170M6412	T	
ACS580-07-0585A-4+B055+C129+H351+H353+H358	R10	8213	28014	1900	1118	72	585	690	170M6413	L	
ACS580-07-0650A-4+B055+C129+H351+H353+H358	R10	10197	34794	1900	1118	72	650	690	170M6414	L	
ACS580-07-0725A-4+B055+C129+H351+H353+H358	R11	11258	38414	2400	1413	72	725	690	170M6416	L	
ACS580-07-0820A-4+B055+C129+H351+H353+H358	R11	12936	44140	2400	1413	72	820	690	170M6416	L	

* Heat dissipation value is a reference for cabinet thermal design

** The maximum noise level is at full fan speed. When the drive is not operating at full load and at maximum ambient temperature the noise level is lower.

***ABB does not require Bussmann brand fuses. Fuses which meet the appropriate UL class type, current rating, and are rated at 600V, 200 kA may be used.

Packaged drive with disconnect means, ACS580-0P 230V

Cooling air flow and input protection fuses for 200 to 240 V units

Type designation	Frame size	Cooling Air Flow 200 to 240 V units						UL Input Protection fuses				
		Heat dissipation*		Air flow		Max. noise level**	I _N	Voltage rating	Bussmann type***	UL class		
		+F255		m3/h	ft3/min						dBa	A
W	BTU/Hr	W	BTU/Hr			m3/h	ft3/min	dBa	A	V		
ACS580-0P-04A6-2	R1	49	168	53	181	42.5	26	59	15	600	KTK-R-15	CC
ACS580-0P-06A6-2	R1	60	205	64	219	42.5	26	59	15	600	KTK-R-15	CC
ACS580-0P-07A5-2	R1	71	243	75	256	42.5	26	59	15	600	KTK-R-15	CC
ACS580-0P-10A6-2	R1	93	318	96	328	42.5	26	59	15	600	KTK-R-15	CC
ACS580-0P-017A-2	R1	141	482	146	499	42.5	26	59	30	600	KTK-R-30	CC
ACS580-0P-024A-2	R2	186	635	192	656	100.3	60	64	40	600	JJS-40	T
ACS580-0P-031A-2	R2	245	836	247	843	100.3	60	64	40	600	JJS-40	T
ACS580-0P-046A-2	R3	352	1202	353	1205	178.4	105	76	80	600	JJS-80	T
ACS580-0P-059A-2	R3	468	1596	472	1611	178.4	105	76	80	600	JJS-80	T
ACS580-0P-075A-2	R4	570	1945	574	1959	288.9	171	69	100	600	JJS-100	T
ACS580-0P-088A-2	R5	676	2307	672	2293	139.4	83	63	110	600	JJS-110	T
ACS580-0P-114A-2	R5	899	3068	906	3092	139.4	83	63	150	600	JJS-150	T
ACS580-0P-143A-2	R6	1103	3764	1117	3812	435	257	67	200	600	JJS-200	T
ACS580-0P-169A-2	R7	1320	4504	1350	4607	450.3	266	67	250	600	JJS-250	T
ACS580-0P-211A-2	R7	1672	5705	1672	5705	450.3	266	67	300	600	JJS-300	T
ACS580-0P-273A-2	R8	2227	7599	2227	7599	1150.3	677	65	400	600	JJS-400	T

* Heat dissipation value is a reference for cabinet thermal design

** The maximum noise level is at full fan speed. When the drive is not operating at full load and at maximum ambient temperature the noise level is lower.

***ABB does not require Bussmann brand fuses. Fuses which meet the appropriate UL class type, current rating, and are rated at 600V, 200 kA may be used.

Cooling and fuses

Packaged drive with disconnect means, ACS580-0P 460V

Cooling air flow and input protection fuses for 460V units

Type designation	Frame size	Cooling Air Flow 460V units							UL Input Protection fuses			
		Heat dissipation*				Air flow		Max. noise level**	I _N	Voltage rating	Bussmann type***	UL class
		+F255				m3/h	ft3/min					
		W	BTU/Hr	W	BTU/Hr			dB	A	V		
ACS580-0P-02A1-4	R1	49	168	53	181	42.5	26	55	15	600	KTK-R-15	CC
ACS580-0P-03A0-4	R1	59	202	63	215	42.5	26	55	15	600	KTK-R-15	CC
ACS580-0P-03A5-4	R1	70	239	74	253	42.5	26	55	15	600	KTK-R-15	CC
ACS580-0P-04A8-4	R1	89	304	93	318	42.5	26	55	15	600	KTK-R-15	CC
ACS580-0P-07A6-4	R1	112	383	116	396	42.5	26	55	15	600	KTK-R-15	CC
ACS580-0P-012A-4	R1	183	625	186	635	42.5	26	55	15	600	KTK-R-15	CC
ACS580-0P-014A-4	R2	235	802	239	816	100.3	60	66	30	600	KTK-R-30	CC
ACS580-0P-023A-4	R2	334	1140	340	1161	100.3	60	66	30	600	KTK-R-30	CC
ACS580-0P-027A-4	R3	443	1512	449	1532	178.4	105	70	40	600	JJS-40	T
ACS580-0P-034A-4	R3	541	1846	545	1860	178.4	105	70	60	600	JJS-60	T
ACS580-0P-044A-4	R3	638	2177	648	2211	178.4	105	70	60	600	JJS-60	T
ACS580-0P-052A-4	R4	873	2979	877	2993	42.5	26	69	80	600	JJS-80	T
ACS580-0P-065A-4	R4	1065	3634	1073	3662	134.3	80	69	100	600	JJS-100	T
ACS580-0P-077A-4	R4	1286	4388	1291	4405	134.3	80	63	100	600	JJS-100	T
ACS580-0P-096A-4	R5	1564	5337	1560	5323	139.4	83	63	150	600	JJS-150	T
ACS580-0P-124A-4	R6	1534	5235	1535	5238	435	257	67	200	600	JJS-200	T
ACS580-0P-156A-4	R7	2045	6978	2051	6999	450.3	266	67	225	600	JJS-225	T
ACS580-0P-180A-4	R7	2417	8247	2447	8350	450.3	266	67	300	600	JJS-300	T
ACS580-0P-240A-4	R8	3486	11895	3486	11895	550.5	324	65	350	600	JJS-350	T

* Heat dissipation value is a reference for cabinet thermal design

** The maximum noise level is at full fan speed. When the drive is not operating at full load and at maximum ambient temperature the noise level is lower.

***ABB does not require Bussmann brand fuses. Fuses which meet the appropriate UL class type, current rating, and are rated at 600V, 200 kA may be used.

Packaged drive with disconnect means, ACS580-0P 600V

Cooling air flow and input protection fuses for 575 V units

Type designation	Frame size	Cooling Air Flow 575V units							UL Input Protection fuses			
		Heat dissipation*				Air flow		Max. noise level**	I _N	Voltage rating	Bussmann type***	UL class
		+F255				m3/h	ft3/min					
		W	BTU/Hr	W	BTU/Hr			dB	A	V		
ACS580-0P-02A7-6	R2	70	239	73	250	100.3	60	64	15	600	KTK-R-15	CC
ACS580-0P-03A9-6	R2	88	301	91	311	100.3	60	64	15	600	KTK-R-15	CC
ACS580-0P-06A1-6	R2	137	468	141	482	100.3	60	64	15	600	KTK-R-15	CC
ACS580-0P-09A0-6	R2	179	611	182	621	100.3	60	64	15	600	KTK-R-15	CC
ACS580-0P-011A-6	R2	234	799	237	809	100.3	60	64	15	600	KTK-R-15	CC
ACS580-0P-017A-6	R2	330	1126	335	1144	42.5	26	64	30	600	KTK-R-30	CC
ACS580-0P-022A-6	R3	438	1495	444	1515	178.4	105	75	40	600	JJS-40	T
ACS580-0P-027A-6	R3	536	1829	542	1850	178.4	105	75	40	600	JJS-40	T
ACS580-0P-032A-6	R3	633	2160	639	2181	178.4	105	75	40	600	JJS-40	T
ACS580-0P-041A-6	R5	867	2959	866	2955	139.4	83	63	100	600	JJS-100	T
ACS580-0P-052A-6	R5	1058	3610	1059	3614	139.4	83	63	100	600	JJS-100	T
ACS580-0P-062A-6	R5	1291	4405	1281	4371	139.4	83	63	100	600	JJS-100	T
ACS580-0P-077A-6	R5	1563	5333	1556	5310	139.4	83	63	100	600	JJS-100	T
ACS580-0P-099A-6	R7	2117	7224	2113	7210	450.3	266	67	150	600	JJS-150	T
ACS580-0P-125A-6	R7	2530	8633	2530	8633	450.3	266	67	200	600	JJS-200	T
ACS580-0P-144A-6	R8	3074	10489	3081	10513	550.5	324	65	250	600	JJS-250	T

* Heat dissipation value is a reference for cabinet thermal design

** The maximum noise level is at full fan speed. When the drive is not operating at full load and at maximum ambient temperature the noise level is lower.

***ABB does not require Bussmann brand fuses. Fuses which meet the appropriate UL class type, current rating, and are rated at 600V, 200 kA may be used.

Cooling and fuses

Packaged drive with Circuit Breaker Disconnect and Two-Contactor Bypass, ACS580-0P 230V

Cooling air flow and recommended input protection fuses for 200 to 240 V units												
Type designation	Frame size	Cooling Air Flow 200 to 240 V units							Recommended UL Input Protection fuses			
		Heat dissipation				Air flow			I _N	Voltage rating	Bussmann type***	UL Class
		Standard		E205+E213		Type 1	Type 12	Type 3R				
		W	BTU/Hr	W	BTU/Hr	ft3/min	ft3/min	ft3/min	A	V		
ACS580-0P-04A6-2+F255+G310	R1	70	239	81	276	195	38	TBD	15	600	KTK-R-15	CC
ACS580-0P-06A6-2+F255+G310	R1	80	273	98	334	195	38	TBD	15	600	KTK-R-15	CC
ACS580-0P-07A5-2+F255+G310	R1	91	310	112	382	195	38	TBD	15	600	KTK-R-15	CC
ACS580-0P-10A6-2+F255+G310	R1	109	372	138	471	195	38	TBD	15	600	KTK-R-15	CC
ACS580-0P-017A-2+F255+G310	R1	188	641	226	771	195	38	TBD	30	600	KTK-R-30	CC
ACS580-0P-024A-2+F255+G310	R2	229	781	277	945	195	115	TBD	40	600	JJS-40	T
ACS580-0P-031A-2+F255+G310	R2	283	965	347	1183	195	115	TBD	40	600	JJS-40	T
ACS580-0P-046A-2+F255+G310	R3	377	1286	462	1575	195	115	TBD	80	600	JJS-80	T
ACS580-0P-059A-2+F255+G310	R3	505	1722	599	2043	195	115	TBD	80	600	JJS-80	T
ACS580-0P-075A-2+F255+G310	R4	600	2046	714	2435	195	286	TBD	100	600	JJS-100	T
ACS580-0P-088A-2+F255+G310	R5	722	2462	857	2922	390	286	TBD	150	600	JJS-150	T
ACS580-0P-114A-2+F255+G310	R5	938	3199	1087	3707	390	286	TBD	150	600	JJS-150	T
ACS580-0P-143A-2+F255+G310	R6	1138	3881	1292	4406	390	286	TBD	200	600	JJS-200	T
ACS580-0P-169A-2+F255+G310	R7	1354	4617	1563	5330	390	286	TBD	250	600	JJS-250	T
ACS580-0P-211A-2+F255+G310	R7	1683	5739	1977	6742	390	286	TBD	300	600	JJS-300	T
ACS580-0P-273A-2+F255+G310	R8	2223	7580	2499	8522	390	393	TBD	400	600	JJS-400	T

** The maximum noise level is at full fan speed. When the drive is not operating at full load and at maximum ambient temperature the noise level is lower.

***ABB does not require Bussmann brand fuses. Fuses which meet the appropriate UL class type, current rating, and are rated at 600V, 200 kA may be used.

Packaged drive with Circuit Breaker Disconnect and Two-Contactor Bypass, ACS580-0P 460V

Cooling air flow and recommended input protection fuses for 460V units												
Type designation	Frame size	Cooling Air Flow 460V units							Recommended UL Input Protection fuses			
		Heat dissipation				Air flow			I _N	Voltage rating	Bussmann type***	UL Class
		Standard		E205+E213		Type 1	Type 12	Type 3R				
		W	BTU/Hr	W	BTU/Hr	ft3/min	ft3/min	ft3/min	A	V		
ACS580-0P-02A1-4+F255+G310	R1	57	194	142	484	195	38	TBD	15	600	KTK-R-15	CC
ACS580-0P-03A0-4+F255+G310	R1	67	228	159	542	195	38	TBD	15	600	KTK-R-15	CC
ACS580-0P-03A5-4+F255+G310	R1	91	310	185	631	195	38	TBD	15	600	KTK-R-15	CC
ACS580-0P-04A8-4+F255+G310	R1	109	372	212	723	195	38	TBD	15	600	KTK-R-15	CC
ACS580-0P-07A6-4+F255+G310	R1	188	641	327	1115	195	38	TBD	15	600	KTK-R-15	CC
ACS580-0P-012A-4+F255+G310	R1	229	781	364	1241	195	38	TBD	15	600	KTK-R-15	CC
ACS580-0P-014A-4+F255+G310	R2	283	965	442	1507	195	115	TBD	30	600	KTK-R-30	CC
ACS580-0P-023A-4+F255+G310	R2	377	1286	552	1882	195	115	TBD	30	600	KTK-R-30	CC
ACS580-0P-027A-4+F255+G310	R3	505	1722	584	1991	195	115	TBD	40	600	JJS-40	T
ACS580-0P-034A-4+F255+G310	R3	600	2046	696	2373	195	115	TBD	60	600	JJS-60	T
ACS580-0P-044A-4+F255+G310	R3	722	2462	827	2820	195	115	TBD	60	600	JJS-60	T
ACS580-0P-052A-4+F255+G310	R4	938	3199	1052	3587	195	115	TBD	80	600	JJS-80	T
ACS580-0P-065A-4+F255+G310	R4	1127	3843	1241	4232	195	115	TBD	100	600	JJS-90	T
ACS580-0P-077A-4+F255+G310	R4	1343	4580	1512	5156	195	286	TBD	100	600	JJS-100	T
ACS580-0P-096A-4+F255+G310	R5	1672	5702	1865	6360	390	286	TBD	150	600	JJS-150	T
ACS580-0P-124A-4+F255+G310	R6	1638	5586	1863	6353	390	286	TBD	200	600	JJS-200	T
ACS580-0P-156A-4+F255+G310	R7	2138	7291	2392	8157	390	286	TBD	225	600	JJS-225	T
ACS580-0P-180A-4+F255+G310	R7	2508	8552	2807	9572	390	413	TBD	300	600	JJS-300	T
ACS580-0P-240A-4+F255+G310	R8	3561	12143	3841	13098	390	452	TBD	350	600	JJS-350	T
ACS580-0P-302A-4+F255+G310	R9	4206	14342	4543	15492	556	556	TBD	500	600	JJS-500	T
ACS580-0P-361A-4+F255+G310	R9	5176	17650	5557	18949	684	684	TBD	500	600	JJS-500	T
ACS580-0P-414A-4+F255+G310	R9	6425	21909	6890	23495	854	854	TBD	600	600	JJS-600	T

** The maximum noise level is at full fan speed. When the drive is not operating at full load and at maximum ambient temperature the noise level is lower.

***ABB does not require Bussmann brand fuses. Fuses which meet the appropriate UL class type, current rating, and are rated at 600V, 200 kA may be used.

Cooling and fuses

Packaged drive with Circuit Breaker Disconnect and Two-Contactor Bypass, ACS580-0P 230V

Cooling air flow and recommended input protection fuses for 575V units												
Type designation	Frame size	Cooling Air Flow 575V units							Recommended UL Input Protection fuses			
		Heat dissipation				Air flow			I _N	Voltage rating	Bussmann type***	UL Class
		Standard		E205+E213		Type 1	Type 12	Type 3R				
W	BTU/Hr	W	BTU/Hr	ft3/min	ft3/min	ft3/min	A	V				
ACS580-0P-02A7-6 +F255+G310	R2	91	310	188	641	195	115	TBD	15	600	KTK-R-15	CC
ACS580-0P-03A9-6 +F255+G310	R2	109	372	207.3	707	195	115	TBD	15	600	KTK-R-15	CC
ACS580-0P-06A1-6 +F255+G310	R2	188	641	312.7	1066	195	115	TBD	15	600	KTK-R-15	CC
ACS580-0P-09A0-6 +F255+G310	R2	229	781	366.9	1251	195	115	TBD	15	600	KTK-R-15	CC
ACS580-0P-011A-6 +F255+G310	R2	283	965	421.8	1438	195	115	TBD	15	600	KTK-R-15	CC
ACS580-0P-017A-6 +F255+G310	R2	377	1286	553.2	1886	195	115	TBD	30	600	KTK-R-30	CC
ACS580-0P-022A-6 +F255+G310	R3	505	1722	576.2	1965	195	115	TBD	40	600	JJS-40	T
ACS580-0P-027A-6 +F255+G310	R3	600	2046	676.7	2308	195	115	TBD	40	600	JJS-40	T
ACS580-0P-032A-6 +F255+G310	R3	722	2462	828	2823	195	115	TBD	40	600	JJS-40	T
ACS580-0P-041A-6 +F255+G310	R5	938	3199	1047	3570	195	115	TBD	100	600	JJS-100	T
ACS580-0P-052A-6 +F255+G310	R5	1127	3843	1250	4263	195	115	TBD	100	600	JJS-100	T
ACS580-0P-062A-6 +F255+G310	R5	1343	4580	1524	5197	195	286	TBD	100	600	JJS-100	T
ACS580-0P-077A-6 +F255+G310	R5	1672	5702	1866	6363	390	286	TBD	100	600	JJS-100	T
ACS580-0P-099A-6 +F255+G310	R7	2223	7580	2417	8242	390	286	TBD	150	600	JJS-150	T
ACS580-0P-125A-6 +F255+G310	R7	2628	8961	2889	9851	390	413	TBD	200	600	JJS-200	T
ACS580-0P-144A-6 +F255+G310	R8	3168	10803	3421	11666	390	413	TBD	250	600	JJS-250	T

** The maximum noise level is at full fan speed. When the drive is not operating at full load and at maximum ambient temperature the noise level is lower.

***ABB does not require Bussmann brand fuses. Fuses which meet the appropriate UL class type, current rating, and are rated at 600V, 200 kA may be used.

Circuit breakers

ACS580-01 drives are suitable for use on a circuit capable of delivering not more than 65 kA symmetrical Amperes (RMS) at 240 / 480 / 600 V maximum when protected by appropriate circuit breakers. Additional fuse protection is not required per UL when using a recommended circuit breaker. Circuit breakers are not required to be in the same enclosure as the drive. Complete information, including limitations on minimum enclosure volume, can be found in hardware manual supplement Branch Circuit Protection for ABB drives, document 3AXD50000645015.

ACS580 drives are compatible with the wide ABB product offering



Programmable Logic Controllers PLCs

The AC500, AC500-eCo, AC500-S and AC500-XC scalable PLC ranges provide solutions for small, medium and high-end applications. Our AC500 PLC platform offers different performance levels and is the ideal choice for high availability, extreme environments, condition monitoring, motion control or safety solutions .



All-compatible drives portfolio

The all-compatible drives share the same architecture; software platform, tools, user interfaces and options. Yet, there is an optimal drive from the smallest water pump to the biggest cement kiln, and everything in between.



AC motors

ABB's low voltage AC motors are designed to save energy, reduce operating costs and minimize unscheduled downtime. Cast iron and aluminum process performance motors provide a broad set of customizable motors for the process industries and heavy-duty applications. Common ratings and mounting configurations in IE3 and IE4 efficiencies are stocked in the US for quick installation.



Safety products

ABB safety products are helping machine builders to create production-friendly and safe work environments for operators. We deliver machine safety solutions for single machines or entire production lines. Our long experience of helping customers making solutions for demanding environments has made us experts in combining production demands with safety demands for production-friendly solutions.



Control panels

CP600-eCo, CP600 and CP600-Pro control panels offer a wide range of features and functionalities for maximum operability. ABB control panels are distinguished by their robustness and easy usability, providing all the relevant information from production plants and machines at a single touch .

Choose the right motor for your application



Choose the best motor for your application. A natural match for induction motors, ABB general purpose drives can also control high-efficiency motors such as permanent magnet or synchronous reluctance motors for greater efficiency.

Induction motors, the industry workhorse

Pair the ACS580 with an induction motor (IM) for simple and reliable operation in many applications and in a wide range of environments. Further simplifying setup, the general purpose drives can be integrated with virtually any type of IM by simply entering the motor nameplate data.

Permanent magnet motors for smooth operation

Permanent magnet technology is used for improved motor characteristics in terms of energy efficiency and power density. This technology is particularly well-suited for low speed control applications, as it eliminates the need to use gear boxes. Even without speed or rotor position sensors, the ACS580 drives is able to control most types of permanent magnet motors.

IE5 SynRM for optimized energy efficiency

Combining ABB's general purpose drive control technology with our synchronous reluctance motors (SynRM) will give you a motor and a drive package that ensures high energy efficiency, reduces motor temperatures, and provides a significant reduction in motor noise. The key is in the efficiency-optimized rotor design of our SynRM motors.

Synchronous reluctance motors

Ultimate efficiency and reliability to optimize your cost of ownership

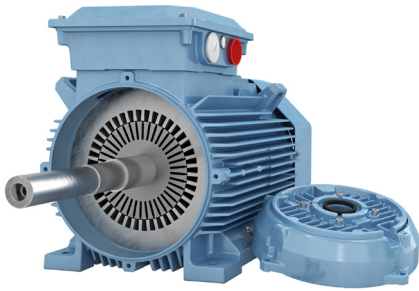

Traditional induction motor

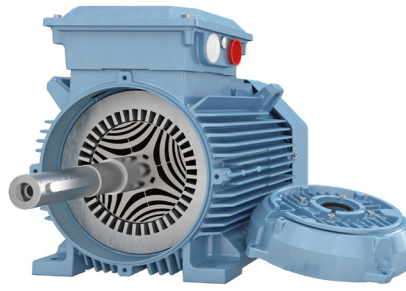

IE5 SynRM motor

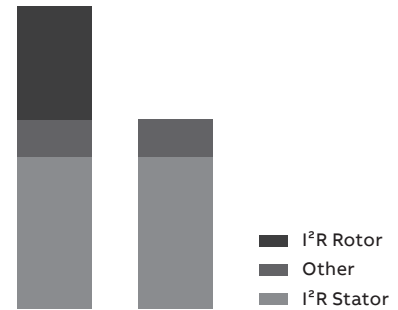

Losses IM vs SynRM

Innovation inside

The idea is simple. Take a conventional, proven stator technology and an innovative rotor design. Package this inside of any one of a variety of mechanical packages including IEC and NEMA designs. Then combine them with an ABB general purpose drive loaded with software with versatile features. Finally, optimize the whole package for applications such as compressors, conveyors, mixers, pumps, centrifuges, fans and many other variable and constant torque applications.

Magnet-free design

Synchronous reluctance technology combines the performance of a permanent magnet motor with the simplicity and service-friendliness of an induction motor. The synchronous reluctance rotor has neither magnets nor windings, and suffers virtually no power losses. And, because there are no magnetic forces in the rotor, maintenance is as straightforward as with induction motors.

Superior reliability to minimize the cost of not running

International Efficiency class IE5 synchronous reluctance motors (SynRM) have very low winding temperatures, which increases the reliability and lifetime of the winding. More importantly, a cool synchronous reluctance rotor means significantly lower bearing temperatures – an important factor because bearing failures cause about 70 percent of unplanned motor outages.

Perfect for retrofits

The SynRM package is a perfect solution for motor retrofits. The IE5 SynRM is the same size as an IE3 induction motor, eliminating the need for mechanical modifications. The increased efficiency will reduce the payback time of the investment, in some cases, to under 12 months.

Full motor control, down to zero speed

Many processes require accurate speed control. SynRM always runs at reference speed with practically no error, even without an encoder. Even the best slip compensation systems in an induction motor inverter will never match the precision of SynRM. Your application may require you to run your motor at slow speeds. If you are using SynRM and your drive cannot provide the necessary torque, it may trip. ABB drives provide full control and torque down to zero speed, even without speed sensors.

For all applications

This is important if you are planning on using the motor with applications other than quadratic torque applications like pumps and fans. Our drives provide full SynRM motor control for constant torque applications such as extruders, conveyors and wire drawing machines.

SynRM technology	Benefit
Higher efficiency IE5	Lowest energy consumption
No rare earth metals	Environmental sustainability
Magnet-free rotor	Easy service
Lower winding and bearing temperatures	Longer life time, extended service intervals
Better controllability	Accurate speed and torque control
Lower noise level	Better working and living environment
Same size as IE3 induction motor	Perfect for retrofits



Selection guide

IE5 synchronous reluctance motors

This table presents performance data for IE5 SynRM motor and ACS580 drive package .

Variant codes and construction details are based on the M3AL (aluminum) or M3BL (cast iron) motor, UL (NEMA) Type 12 / IP55, IC 411 (TEFC), insulation class F, temperature rise class B. For performance data with other mechanical packages, please contact your local ABB sales office or Global Customer Support (GCS) team.

Output (kW)	Motor type *)	Product code	Motor efficiency (%)	Motor nominal current (A)	Motor nominal torque (Nm)	Motor weight (kg)	Matched ACS580-01 drive	Package efficiency **) IES at nominal point (Pn) (%)	PDS ***) IES2 efficiency class low limit (%)	Package efficiency above IES2 efficiency class low limit (%)	Drive frame size
3000 RPM / 100 Hz						400 V network					
5.5	M3AL132SMA4	3GAL132217-...C	92.8	12.1	17.5	41	ACS580-01-12A7-4	89.6	82.5	8.6	R1
7.5	M3AL132SMB4	3GAL132227-...C	93.1	16.5	23.9	41	ACS580-01-018A-4	90.4	83.9	7.7	R2
11	M3AL132SMC4	3GAL132237-...C	94.0	24.5	35.0	47	ACS580-01-026A-4	90.9	85.3	6.6	R2
11	M3BL160MLA4	3GBL162417-...C	93.7	25.6	35.0	133	ACS580-01-026A-4	90.7	85.3	6.3	R2
15	M3AL132SMD4	3GAL132247-...C	94.1	32.9	47.8	47	ACS580-01-039A-4	91.3	86.2	5.9	R3
15	M3BL160MLB4	3GBL162427-...C	95.1	34.6	48.0	133	ACS580-01-039A-4	92.4	86.2	7.2	R3
18.5	M3BL160MLC4	3GBL162437-...C	94.6	43.3	59.0	133	ACS580-01-046A-4	91.5	86.9	5.3	R3
22	M3BL180MLA4	3GBL182417-...C	94.8	49.5	70.0	160	ACS580-01-062A-4	91.8	87.3	5.2	R4
30	M3BL200MLA4	3GBL202417-...C	94.6	68.3	95.0	259	ACS580-01-073A-4	91.4	88.1	3.7	R4
37	M3BL200MLB4	3GBL202427-...C	95.5	84.5	118.0	259	ACS580-01-088A-4	92.6	88.6	4.5	R5
45	M3BL225SMA4	3GBL222217-...C	96.0	101.0	143.0	282	ACS580-01-106A-4	93.4	89.0	4.9	R5
55	M3BL225SMF4	3GBL222267-...C	95.3	124.0	175.0	282	ACS580-01-145A-4	92.7	89.4	3.7	R6
1500 RPM / 50 Hz											
5.5	M3AL132SMA4	3GAL32213-...C	93.7	11.7	35.0	63	ACS580-01-12A7-4	90.7	82.5	9.9	R1
7.5	M3AL132SMB4	3GAL132223-...C	93.7	15.7	47.8	63	ACS580-01-018A-4	91.3	83.9	8.8	R2
11	M3AL132SMC4	3GAL132233-...C	94.2	23.8	70.0	69	ACS580-01-026A-4	91.2	85.3	6.9	R2
11	M3BL160MLA4	3GBL162413-...C	94.0	24.2	70.0	160	ACS580-01-026A-4	91.2	85.3	6.9	R2
15	M3BL160MLB4	3GBL62423-...C	94.8	32.1	95.0	177	ACS580-01-039A-4	92.3	86.2	7.1	R3
18.5	M3BL180MLA4	3GBL182413-...C	94.3	40.3	118.0	177	ACS580-01-046A-4	91.6	86.9	5.4	R3
22	M3BL200MLF4	3GBL202463-...C	95.7	48.1	140.0	304	ACS580-01-062A-4	92.9	87.3	6.4	R4
30	M3BL200MLA4	3GBL202413-...C	95.3	66.1	191.0	304	ACS580-01-073A-4	92.1	88.1	4.5	R4
37	M3BL250SMF4	3GBL252263-...C	95.5	83.0	236.0	428	ACS580-01-088A-4	93.0	88.6	5.0	R5
45	M3BL250SMG4	3GBL252273-...C	95.6	98.9	286.0	428	ACS580-01-106A-4	93.3	89.0	4.8	R5
55	M3BL250SMA4	3GBL252213-...C	95.6	119.0	350.0	454	ACS580-01-145A-4	92.8	89.4	3.8	R6
75	M3BL280SMA4	3GBL282213-...C	96.1	166.0	478.0	639	ACS580-01-206A-4	93.3	90.0	3.7	R7
90	M3BL280SMB4	3GBL282223-...C	96.5	199.0	573.0	639	ACS580-01-206A-4	93.6	90.2	3.8	R7
110	M3BL280SMC4	3GBL282233-...C	96.7	241.0	699.0	697	ACS580-01-246A-4	94.0	90.5	3.9	R8
110	M3BL315SMA4	3GBL312213-...C	96.8	243.0	702.0	873	ACS580-01-246A-4	94.1	90.5	4.0	R8
132	M3BL315SMB4	3GBL312223-...C	96.8	290.0	842.0	925	ACS580-01-293A-4	93.9	90.7	3.5	R8
160	M3BL315SMC4	3GBL312233-...C	97.1	343.0	1018.0	965	ACS580-01-363A-4	94.3	90.9	3.7	R9
200	M3BL315MLA4	3GBL312413-...C	97.2	428.0	1272.0	1116	ACS580-01-430A-4	94.2	91.1	3.4	R9
250	M3BL315LKA4	3GBL312813-...C	97.1	552.0	1591.0	1357	ACS580-04-585A-4	94.7	91.2	3.8	R9
315	M3BL315LKC4	3GBL312833-...C	97.2	662.0	2006.0	1533	ACS580-04-650A-4	94.7	91.2	3.8	R9

*) Motor type M3AL = aluminum motor frame
Motor type M3BL = cast iron motor frame

**) Calculated package efficiency values for ACS580-01
***) PDS = Power Drive System

ABB Access

Scan the QR code to access 24/7 self-services for ABB drives, motors and PLCs

With ABB Access, you can unlock all aspects of your drives, motors or PLCs, from one central location: the palm of your hand.

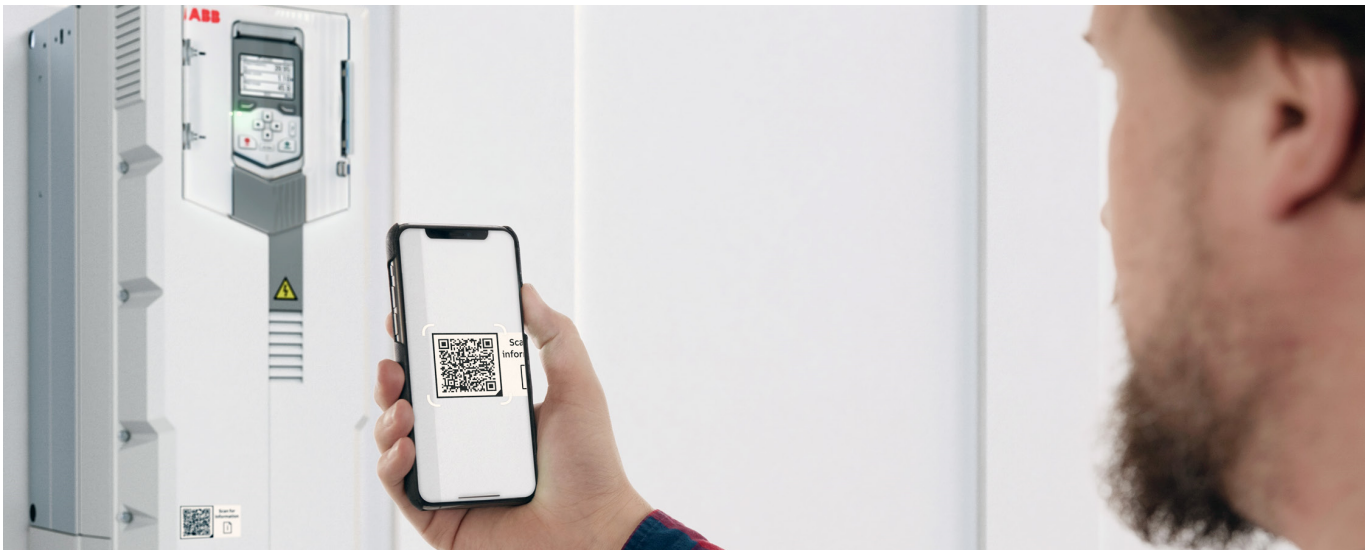

Simply scan the QR code on the ABB product to get started

ABB Access, helps you easily find up-to-date product online data. It also provides easy access to documentation and manuals. If you happen to experience issues with your ABB product, this can be fastly and easily reported online to reach expert support from ABB.

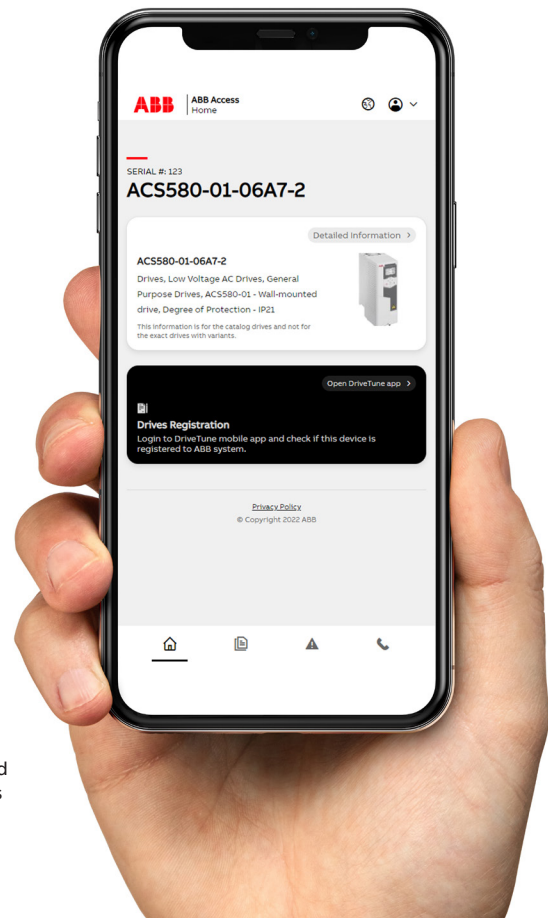
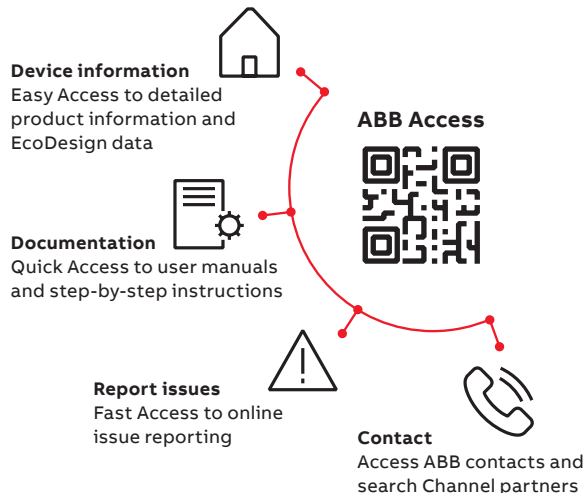

Drivetune mobile application for wireless access

User-friendly experience with Bluetooth connectivity.

Drivetune mobile app is a powerful tool for performing basic drive startup and troubleshooting tasks. It is possible to connect with drives and access data available in the Internet at the same time. The wireless Bluetooth connectivity means

that users do not need to enter hazardous or difficult-to-reach work areas to access information necessary to help them commission and tune the drive.



- Start up, commission and tune your drive and application with full parameter access
- Optimize performance via drive troubleshooting features
- Create and share backups and support packages
- Keep track of drives installed base

ABB Ability™ Mobile Connect for drives is a module in the Drivetune app. It gives you the access to the technical support for fast problem solving. Mobile Connect makes all the necessary data instantly available to the expert, providing support .

Remote and rapid access to ABB's drive experts can save you and your team considerable time, money and headaches. Check Mobile Connect availability in your country.



Download Drivetune



Drivetune for commissioning and managing drives

ABB SmartGuide – ACS580

Being one of the handiest ways to get short and clear visual instructions on drive installation, startup, and operation.

Mobile-friendly digital user guides provide simple and animated step-by-step instructions to assist with wall mounting of drives, electrical installation and drive programming. The content is frequently updated and further developed, making it your comprehensive source of instructions and help.

Scan the QR code and test it yourself!

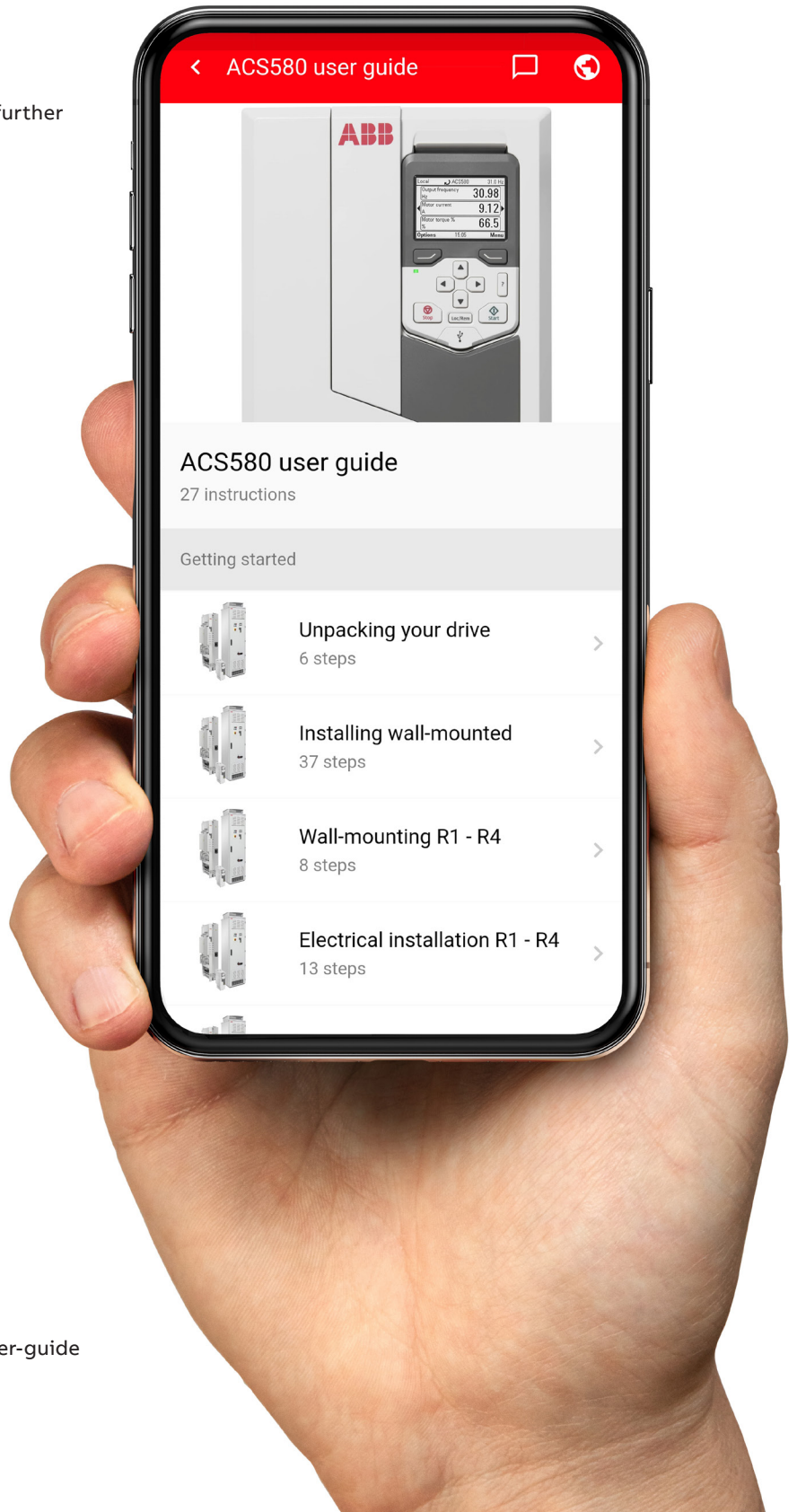

<https://drives-abb.swipeguide.com/guide/acs580-user-guide>
<https://drives-abb.swipeguide.com/>

Our service expertise, your advantage

ABB Motion Services helps customers around the globe by maximizing uptime, extending product life cycle, and enhancing the performance and energy efficiency of electrical motion solutions. We enable innovation and success through digitalization by securely connecting and monitoring our customers' motors and drives, increasing operational uptime, and improving efficiency. We make the difference for our customers and partners every day by keeping their operations running profitably, safely and reliably.

With a service offering tailored to your needs, ABB Motion Services maximizes the uptime and extends the life cycle of your electrical motion solutions, while optimizing their performance and maximizing your energy efficiency gains throughout the entire lifetime of your applications. We help to keep your applications turning profitably, safely and reliably.

Digitalization enables new smart and secured ways to prevent unexpected downtime while optimizing the operation and maintenance of your assets. We securely connect and monitor your motors, drives or your entire powertrain via our easy-to-use cloud service solutions. Connecting your applications also gives you access to our in-depth service domain expertise.

We quickly respond to your service needs. Together with our partners, local field service experts, and service workshop

networks, we provide and install original spare parts to help resolve any issues and minimize the impact of unexpected disruptions.

Our tailored to your needs service offerings and digital solutions will enable you to unlock new possibilities. Not only are we your premier supplier of motion equipment, we are your trusted partner and advisor offering support throughout the entire life cycle of your assets. We ensure your operations run profitably, safely and reliably and continue to drive real world results, now and in the future. Our service teams work with you, delivering the expertise needed to keep your world turning while saving energy every day.

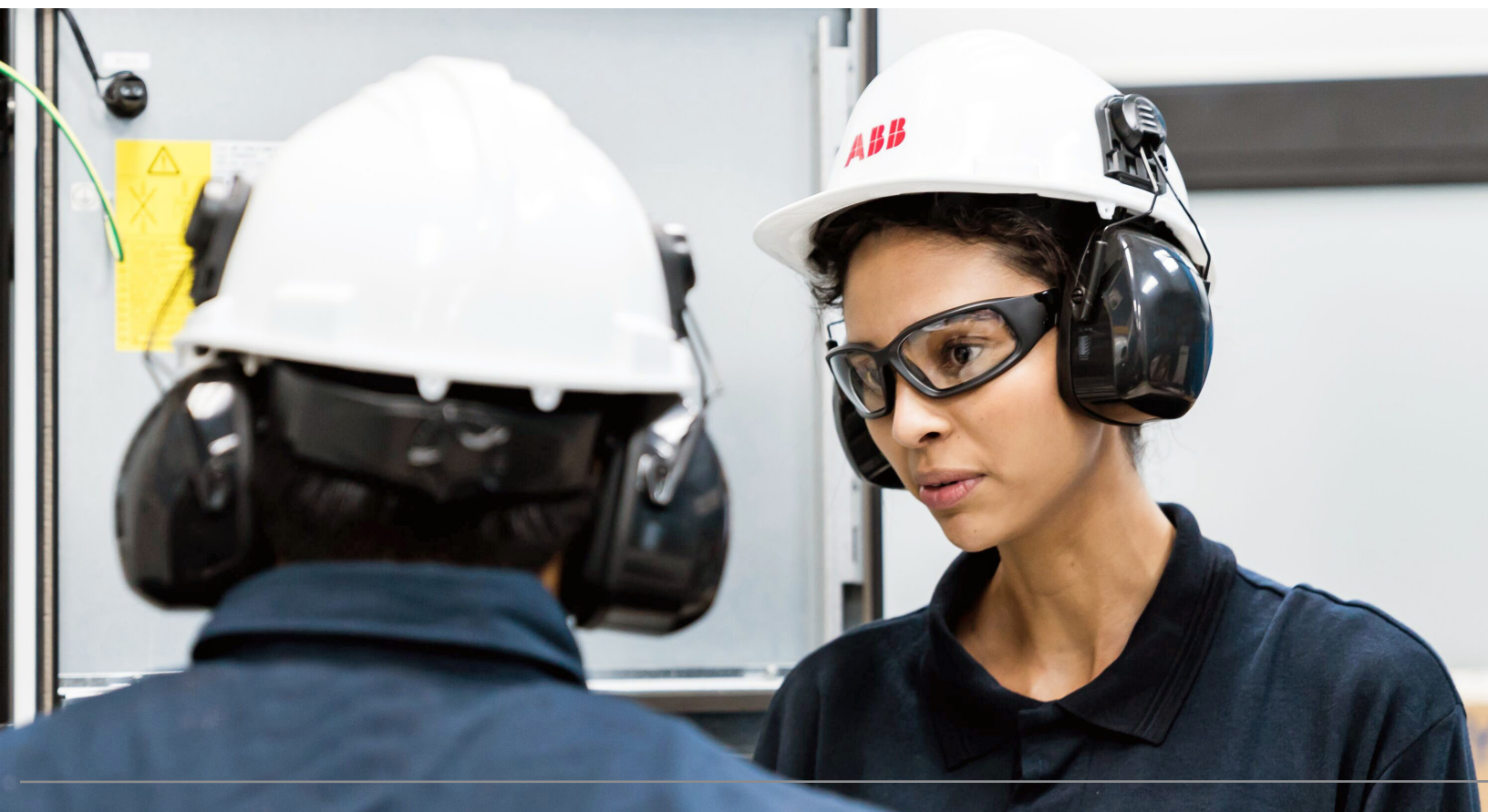

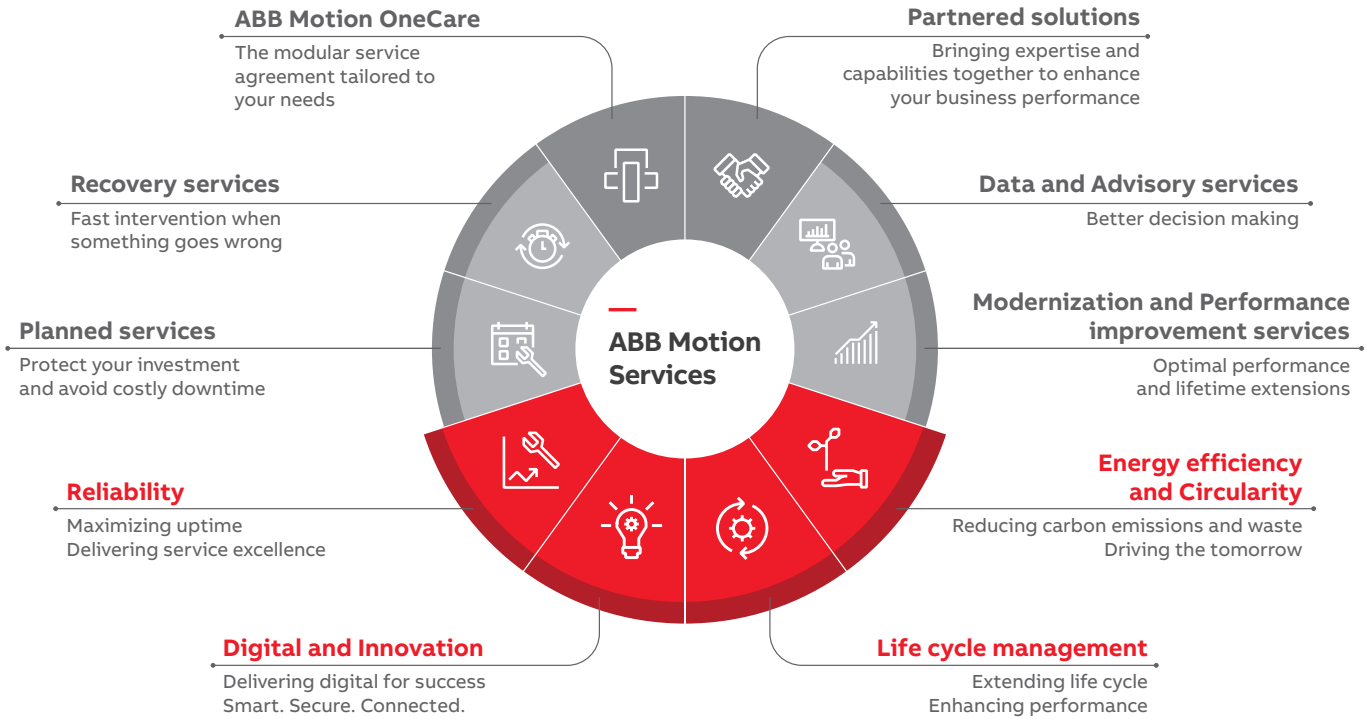

OUR EXPERTISE
YOUR ADVANTAGE

ABB Drives Life Cycle Management

A life time of peak performance

You're in control of every life cycle phase of your drives. At the heart of drive services is a four-phase product life cycle management model. This model defines the services recommended and available throughout drives lifespan.

Now it's easy for you to see the exact service and maintenance available for your drives .

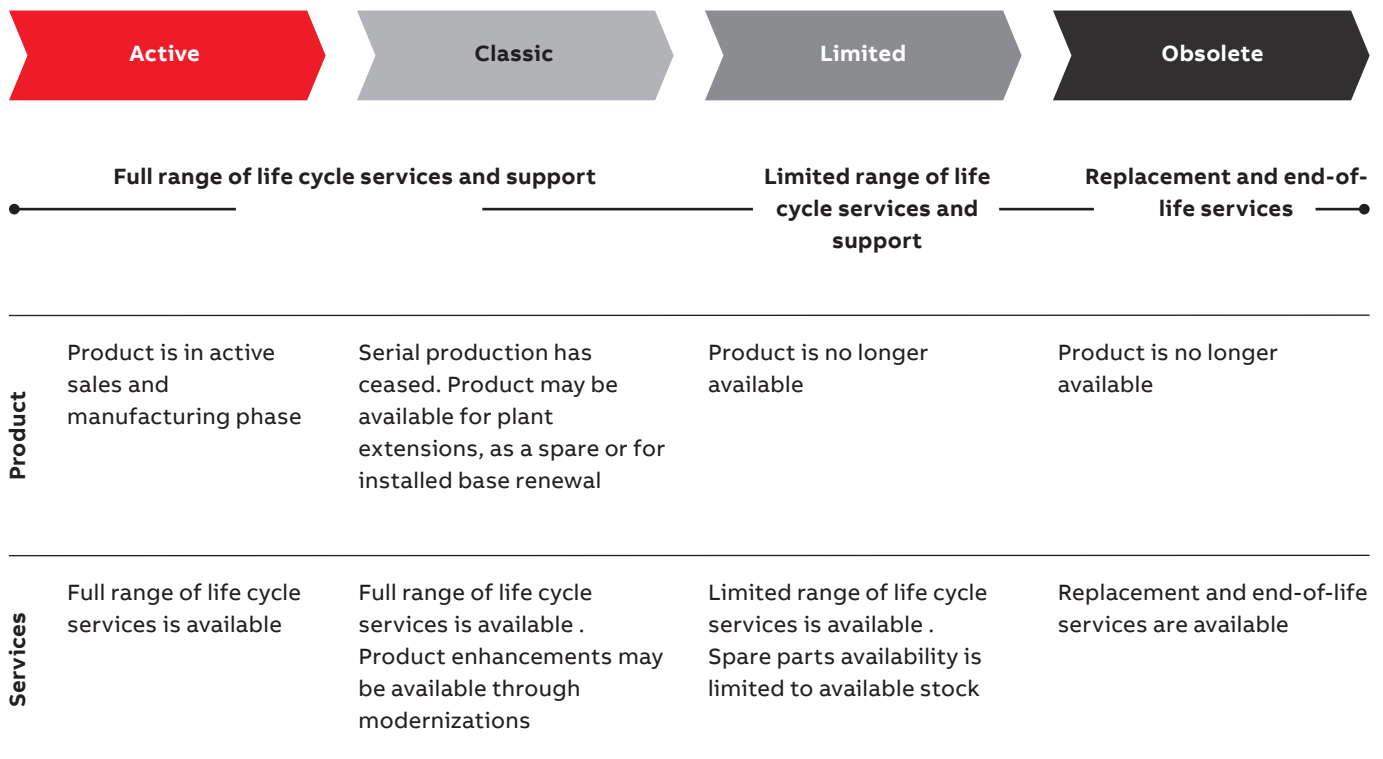

Keeping you informed throughout the life cycle

We notify you every step of the way using life cycle status statements and announcements .

Your benefit is clear information about your drives' status and precise services available. It helps you plan the preferred service actions ahead of time and make sure that continuous support is always available.

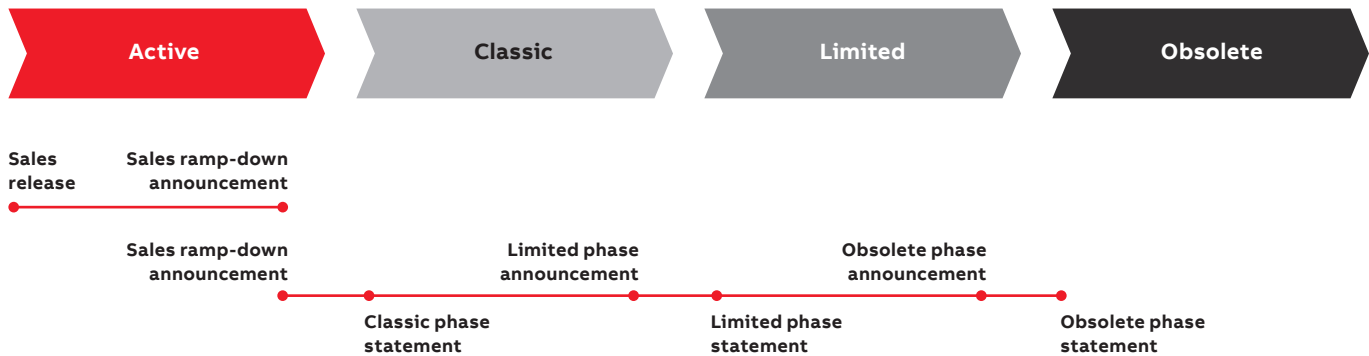

Sales release

Details about product portfolio and release schedule.

Sales ramp down announcement

Last time buy and last deliveries dates, informed well in advance.

Life cycle phase change announcement

Early information about the upcoming life cycle phase change and affects on the service availability. Informed well in advance, minimum six months prior to the change .

Life cycle phase statement

Information about the current life cycle status, product and services availability and recommended actions. Plan for the next life cycle phase transition.

Ordering information

How do I build an ordering code?

ACS580-01

The type designation tells you the specifications and configuration of the drive.

The table shows the primary drive variants.

Sample type code: ACS580-01-07A6-4+XXXX

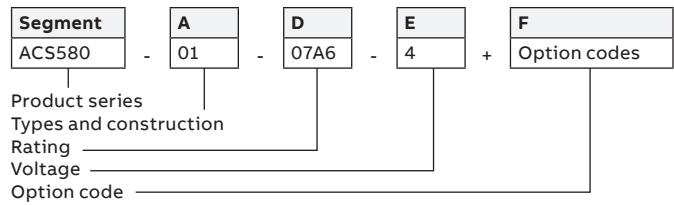

Basic codes

Segment	Option	Description
A	Construction	01 = When no options are selected: Wall mounted, UL (NEMA) Type 1 / IP21, assistant control panel with a USB port, choke, EMC C2 filter (internal EMC filter), safe torque off, braking chopper in frames R1, R2, R3, coated boards, cable lead through entry from the bottom, cable box or the conduit plate with cable entries, quick installation and start-up guide
D	Current rating	Refer to the rating table
E	Voltage rating	2 = 208/230 V 4 = 460 V 6 = 575 V

Option codes

Segment	Option	Code	Description
F	Control panel and panel options	+0J400	Removes control panel
		+J424	CDUM-01 Blank control panel cover (no control panel)
		+J425	ACS-AP-I Assistant control panel
		+J429	ACS-AP-W Assistant control panel with a Bluetooth interface
I/O (one slot available for I/O options)	+L500	CBAI-01 Bipolar analog I/O adapter module	
	+L501	CMOD-01 External 24 V AC/DC and digital I/O extension (2×RO and 1×DO)	
	+L512	CHDI-01 115/230 V Digital input extension (6×DI and 2×RO)	
	+L523	CMOD-02 External 24 V AC/DC and isolated PTC interface	
	+L525	CAIO-01 analog signal extension (3 x AI and 2 x AO)	
	+L537	CPTC-02 ATEX-certified PTC interface, Ex II (2) GD and external 24 V. Requires also option +Q971.	
Safety	+Q971	ATEX-certified Safe Disconnection Function, Ex II (2) GD. Sold only with option +L537.	
	+Q986	PROFIsafe safety functions module (FSPS-21)	
Fieldbus	+K451	DeviceNet™ (FDNA-01)	
	+K454	PROFIBUS® DP (FPBA-01)	
	+K457	CANopen® (FCAN-01)	
	+K458	Modbus(R) RTU (FSCA-01)	
	+K462	ControlNet™ (FCNA-01)	
	+K469	EtherCAT® (FECA-01)	
	+K470	Ethernet POWERLINK (FEPL-01)	
	+K475	2-port Ethernet (EtherNet/IP™, Modbus®/TCP, PROFINET®)	
	+K490	EtherNet/IP™ (FEIP-21)	
	+K491	Modbus®/TCP (FMBT-21)	
IP enclosure	+B056	UL (NEMA) Type 12 / IP55. Factory option, retrofit not possible.	
	+B066	UL (NEMA) Type 4X / IP66. Factory option; retrofit not possible.	
Construction	+C135	Flange mounting kit. (Only available for 400V UL (NEMA) Type 1 / IP21 drives)	
	+P918	Manufactured in the U.S.	
Complementary options	+C219	Overall drive (R1-R5 frames) to comply with class C4 (IEC60721-3-3:2019/ISO9223) or class 3C3 (IEC60721-3-3:2002), ammonia only	
Documentation	R700	English manual - printed copies	
Software	+N8057	Cavitation detection and cooling compressor control software	
Option kits	3AUA0000235813	VFD-Gateway: Ethernet/IP Gateway module (separately mounted)	
	CCA-01	Cold configuration adapter (CCA)	
	DCPT-01	(See page 44) Drive Composer Pro	
	DPMP-0x	(See page 38) Control panel door mounting kit	
	Reactors	dV/dt filters Available on request	
	PowerOhm	Braking modules and braking resistors Available on request	

ACS580-0P

The type designation tells you the specifications and configuration of the drive.

The table shows the primary drive variants.

Sample type code: ACS580-0P-031A-4+XXXX

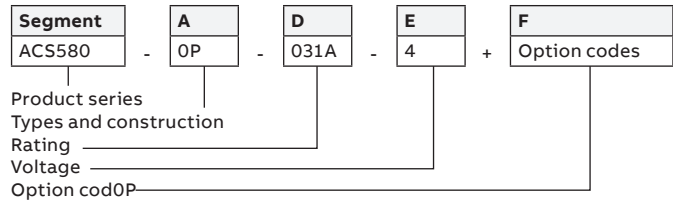

Basic codes

Segment	Option	Description
A	Construction	0P = When no options are selected: Wall mounted, IP21 (UL Type 1) with input disconnect switch and fuses, assistant control panel with USB port. Within the base drive: choke, EMC C2 filter (internal EMC filter), safe torque off, braking chopper in frames R1, R2, R3, coated boards. Cable entry/exit from the bottom (R1-R4), from the top (R5-R8), Quick installation and start-up guide.
D	Current rating	Refer to the rating table
E	Voltage rating	2 = 208/230 V 4 = 460 V 6 = 575 V

Option codes

Segment	Option	Code	Description
F	Control panel and panel options	+J424	Blank panel cover without control panel
		+J425	Assistant control panel /ACS-AP-I (+J425 and +J404 replaces +J400 / ACS-AP-S)
		+J429	Assistant control panel with Bluetooth interface / ACS-AP-W
	I/O (one slot available for I/O options) (L501, L523 and L512 available as retrofit options)	+L500	CBAI-01 Bipolar analog I/O adapter module
		+L501	External 24 V DC/AC and Digital I/O extension (2xRO and 1xDO) / CMOD-01
		+L512	115/230V Digital input (6xDI and 2xRO) / CHDI-01
		+L523	External 24 V and isolated PTC interface / CMOD-02
		+L525	CAIO-01 analog signal extension (3 x AI and 2 x AO)
	Safety	+L537	ATEX-certified PTC interface, Ex II (2) GD and external 24 V / CPTC-02. Requires also +Q971 option.
		+Q971	ATEX-certified Safe Disconnection Function, Ex II (2) GD / CPTC-02 (+Q971 option sold only together with +L537 option)
(One fieldbus adapter supported. Fieldbus adapters available as loose options for retrofit.)	Fieldbus	+K451	DeviceNet™ (FDNA-01)
		+K454	PROFIBUS® DP (FPBA-01)
		+K457	CANopen® (FCAN-01)
		+K458	Modbus(R) RTU (FSCA-01)
		+K462	ControlNet™ (FCNA-01)
		+K469	EtherCAT® (FECA-01)
		+K470	Ethernet POWERLINK (FEPL-01)
		+K475	2-port Ethernet (EtherNet/IP™, Modbus®/TCP, PROFINET®)
		+K490	EtherNet/IP™ (FEIP-21)
		+K491	Modbus®/TCP (FMBT-21)
IP enclosure	+B056	UL (NEMA) Type 12 / IP55	
	+B058	UL (NEMA) Type 3R	
Construction	+F255	Circuit breaker disconnect (replaces disconnect switch)	
	+F267	Service switch (only with G310)	
	+G310	Two-contactor bypass (only with F255)	
Option kits	3AUA0000235813	VFD-Gateway: Ethernet/IP Gateway module (separately mounted)	
	CCA-01	Cold configuration adapter (CCA)	
	DCPT-01	(See page 44) Drive Composer Pro	
	DPMP-0x	(See page 38) Control panel door mounting kit	
	Reactors	dV/dt filters Available on request	
	PowerOhm	Braking modules and braking resistors Available on request	

Ordering information

How do I build an ordering code?

ACS580-07

The type designation tells you the specifications and configuration of the drive.

The table shows the primary drive variants.

Sample type code: ACS580-07-246A-4+XXXX

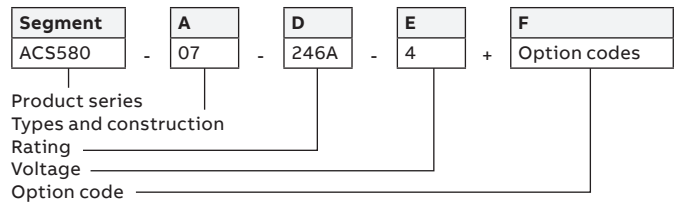

Basic codes

Segment	Option	Description
A	Construction	07 = Cabinet-built, UL (NEMA) Type 1 / IP21, Main switch and UL fuses, Assistant control panel (ACS-AP-S), EMC filter C2 (R8-R9)/ C3 (R10-R11), Common mode filter (R10-R11), ACS580 standard control program, Safe torque-off, coated circuit boards, Bottom entry and exit of cables, Cable lead through entry, One set of default electronic documents
D	Current rating	Refer to the rating table
E	Voltage rating	4 = 380...480 V

ACS580-07 drives are available in North America with a standard set of options including:

Segment	Code	Description
F	+B055	UL (NEMA) Type 12 / IP54
	+C129	UL listed (UL 508C, changing to UL 508A in 2024)
	+H351	Top cable entry
	+H353	Top cable exit
	+H358	Cable conduit entry



—
For more information, please contact
your local ABB representative or visit

new.abb.com/drives/ACS580
new.abb.com/drives/general-purpose
new.abb.com/drives
new.abb.com/drives/drivespartners
new.abb.com/motors-generators

ACS580 technical animation video



Video playlist:

ACS580 how-to videos

