



UNITROL® 1000

Compact and powerful
Automatic voltage regulators

Product benefits



ABB is the world leading volume supplier of high quality UNITROL automatic voltage regulators (AVR) and static excitation systems (SES) that offers solutions for any type and size of power plant with high return on investment. UNITROL 1000 product family covers low power range applications and sets a new benchmark for the global industry with respect to functionality, reliability and connectivity.

UNITROL 1000 provides compact and reliable solutions. Various built-in control software functions, robust mechanical and electrical design enable a wide range of applications.

Main features

- Compact and robust AVR for excitation current up to 20 A
- Separate communication and control processors
- Wide range of built-in control software functions
- Ethernet-based fieldbus interface
- Wide range of power input voltage, for AC and DC input
- Flexible and freely configurable measurements and inputs/outputs (I/Os)

Wide range of applications

- Land-based power plants based on diesel engines, gas or steam turbines and hydro turbines
- Marine: electrical propulsion and auxiliary supply
- Traction: diesel electric locomotives
- Wind: based on direct connected synchronous machines
- Synchronous motors
- Variable speed application

Key benefits

+ Stable and reliable control of your machine

Highly integrated and robust AVR for harsh industrial environment. Stable and accurate regulation even with highly disturbed voltages.

+ AVR for various applications

Fully configurable I/Os and measurement inputs and user-specific configurable fieldbus interface enable easy plant integration.

+ Easy operation, monitoring and maintenance of the system

Intuitive and user-friendly commissioning tool.

+ Full support for grid codes

Built-in Power System Stabilizer (option), simulation models and grid code studies available.

+ Efficient product life cycle management

Extended life time of your assets with minimum costs.

+ Professional technical help always within your reach

ABB's global excitation service network.

Portfolio

UNITROL 1005, UNITROL 1010 and UNITROL 1020 are the latest products of the UNITROL 1000 family. For most reliable operation, the communication and control tasks are split into separate controllers. The non-volatile flash memory of the AVR stores events and data logs to enable fault analysis and fast trouble shooting. Time synchronization is done over Ethernet communication, and the events and data logs are time-stamped.

UNITROL 1000 is provided with modern communication ports like Ethernet and USB for connection of the PC-based commissioning tool CMT 1000.

Besides it is possible to power up the controller of the device via USB port. Thus the user can download files or configure the device even when no input power is available. The AVR output stage is based on proven IGBT technology, which allows AC and/or DC voltage inputs from different sources.

UNITROL 1005, UNITROL 1010 and UNITROL 1020 are designed for a wide range of ambient temperature and harsh environmental conditions and can be mounted directly on the machine.

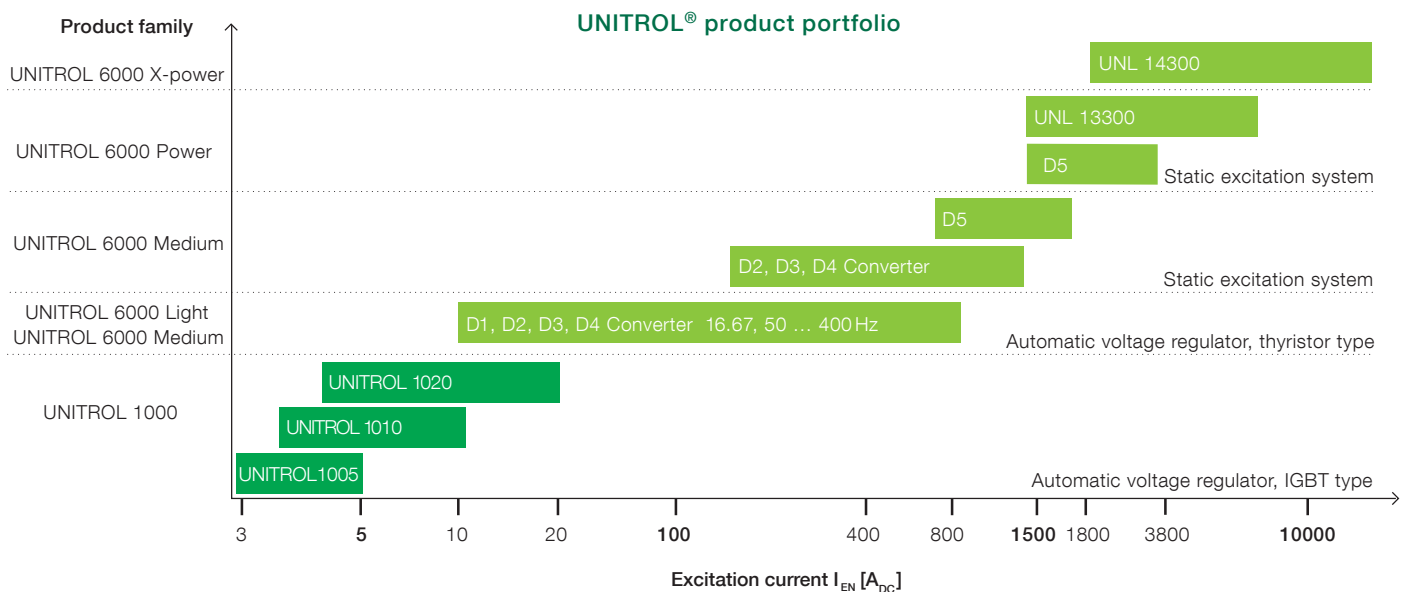

Overview

UNITROL® 1010 and UNITROL® 1020

UNITROL 1020 combines high performance control and power circuits with a simple mechanical design. The construction provides a platform for a broad range of small applications, including those in highly demanding

environmental conditions. Furthermore, high levels of EMC immunity are achieved through separation of the power and measurement terminals from the I/O connectors.

Polymer housing

Protects all live parts to prevent electric shocks

USB port

- Connects the CMT1000 (commissioning and maintenance tool)
- Device configuration and event and data upload without any other power supply

Indication LEDs

- Green: Power ON, blinking indicates software is running
- Yellow: Excitation ON, blinking indicates limiter is active
- Red: Alarm, blinking indicates start-up error

Ethernet port

- Connects the CMT1000
- Remote access over Modbus TCP

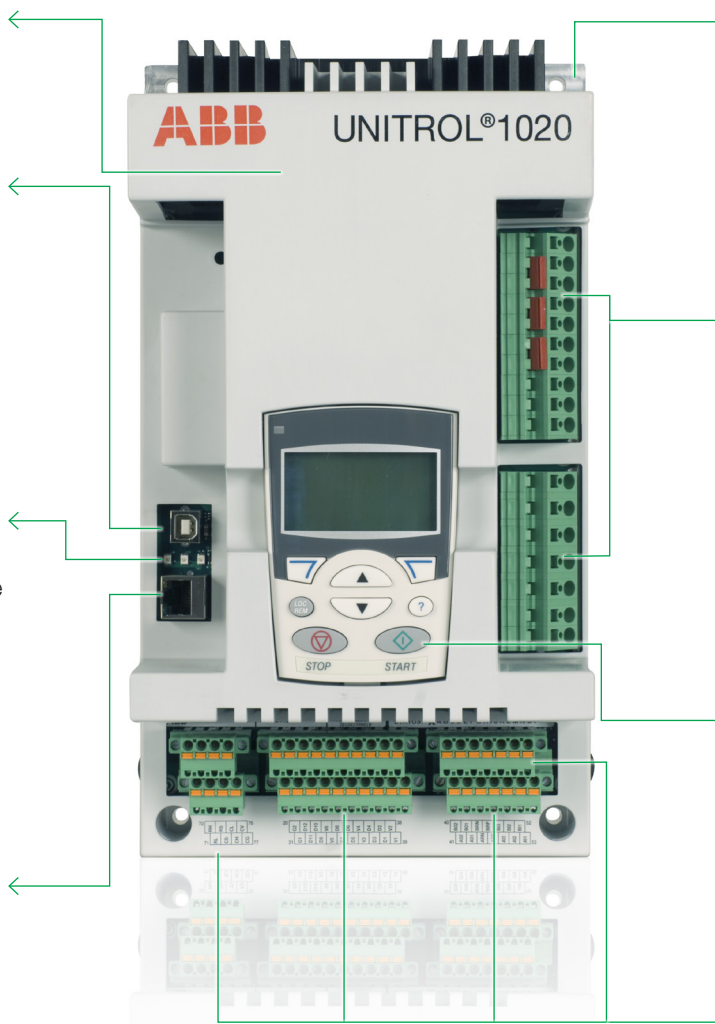

Solid aluminum base plate

- Robust mechanical design allows use in high vibration applications
- Can be mounted directly within the machine terminal box

Power and measurement terminals

- Specified for up to 30 A continuous current and max. cable up to 4 mm² (AWG 24–10)
- Tension spring terminals for reliable connection
- Easy access over test points

Local human interface

- Intuitive local control panel for indication of AVR status, active limiters and measurements
- Local control can be taken over to change parameters

Analog and digital inputs and outputs, serial fieldbus

Tension spring connectors allow reliable wiring and fast replacement

Local human-machine interface provides immediate data on AVR status.

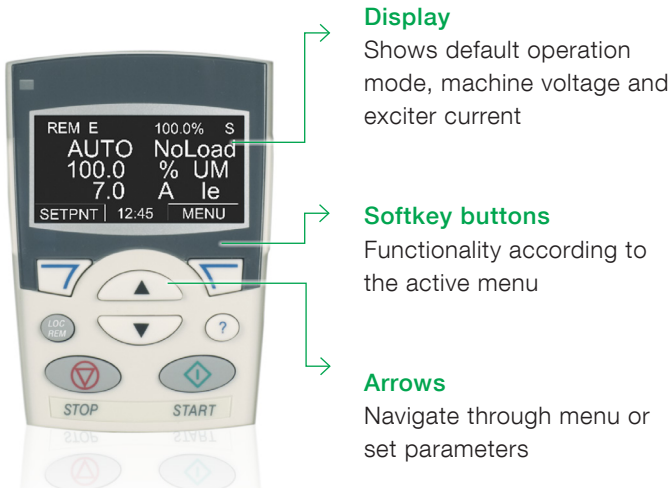

Display

Shows default operation mode, machine voltage and exciter current

Softkey buttons

Functionality according to the active menu

Arrows

Navigate through menu or set parameters

The UNITROL 1000 family has freely configurable measurement and analog or digital I/Os. The configuration is done via the local human-machine interface or CMT1000 software.

Power terminals

- 3-phase excitation power input
- 3-phase auxiliary power input (control power supply)
- Excitation output

Measurement terminals

- 3-phase machine voltage
- 1-phase network voltage
- 1-phase machine current

Analog I/O

- 2 outputs / 3 inputs (configurable)
- +10V / -10V reference output

Digital I/O

- 4 inputs only (configurable)
- 8 inputs / outputs (configurable)
- 24V output (600 mA) for external relay

Serial fieldbus

- RS485 for Modbus RTU or VDC communication
- CAN for dual channel communication

UNITROL 1010 is a compact device with limited functionality and is designed for excitation currents up to 10A nominal. It supports the same interfaces and has the same mechanical footprint as UNITROL 1020.



UNITROL 1010 and UNITROL 1020

Overview

UNITROL® 1005

UNITROL 1005 extends the UNITROL 1000 product family to low end excitation application with maximum excitation current up to 5 A_{DC}. All UNITROL 1000 products are based on the same target software source code, therefore equal performance can be guaranteed as with UNITROL 1010/20. As a further benefit the

same simulation models can be used for the entire UNITROL 1000 product family. That makes UNITROL 1005 also suitable for very demanding grid code applications. UNITROL 1005 comes along with the free of charge compromising and maintenance tool CMT1000, which allows focused and fast commissioning.

Ethernet port

- Connects the CMT1000
- Remote access over Modbus TCP

USB port

- Connects the CMT1000 (commissioning and maintenance tool)

Indication LEDs

- Green: Power ON, blinking indicates software is running
- Yellow: Excitation ON, blinking indicates limiter is active
- Red: Alarm, blinking indicates start-up error

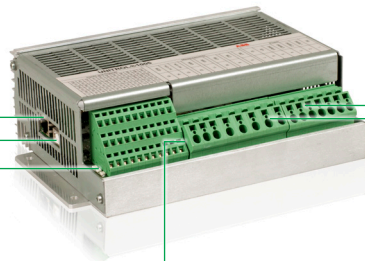

I/Os

- Analog or digital
- 8 digital inputs
- 2 digital outputs
- 2 potential-free outputs
- 2 analog inputs (0...20 mA)

Power terminals

- Specified up to 30 A continuous current and max. cable up to 4 mm² (AWG 24–10)
- Tension spring terminals for reliable connection
- Easy access over test points

Measurement terminals

- Single- or three-phase machine voltage
- Single-phase machine current
- Excitation current
- Excitation voltage
- Rectified input voltage

Hardware types overview

	UNITROL 1005	UNITROL 1010	UNITROL 1020
Excitation current at 55 °C	5 A cont.* 10 A ceiling	10 A cont. 20 A ceiling	20 A cont.** 38 A ceiling
Separate terminals for aux power supply	NO	YES	YES
HMI	NO	NO	YES
I/Os	4 digital outputs 8 digital inputs 2 analog inputs	8 digital I/Os 4 digital inputs 3 analog inputs 2 analog outputs	8 digital I/Os 4 digital inputs 3 analog inputs 2 analog outputs
Interfaces	USB Ethernet	USB RS485 Ethernet (CAN)	USB RS485 Ethernet (CAN)
Mechanicals	IP20 Suitable for machine mounting	IP20 Suitable for machine mounting	IP20 Suitable for machine mounting
Certificates	CE, (DNV/GL), (cUL), Traction	CE, cUL, DNV, GL, CCS, Traction	CE, cUL, DNV, GL, CCS, Traction

*) at 70 °C ambient temperature / **) I_e > 15 A requires external capacitor

Control software

The **UNITROL 1000 software has all the functions necessary for modern excitation systems. ABB offers three software-function packages out of the shelf.**

ECO

The **ECO** version covers essential functionality for cost sensitive applications where limited software functionality is required:

- Regulator control modes: Bumpless transfer between all modes
 - Automatic voltage regulator (AVR)
 - Field current regulator (FCR)
 - Power factor regulator (PF)
 - Reactive power regulator (VAR)
- Limiters: Keeping synchronous machines in a safe and stable operation area
 - Excitation current limiter (min./max.)
 - PQ minimum limiter
 - Machine current limiter
 - V/Hz limiter
 - Machine voltage limiter
 - Protection / Monitoring
- Soft-start and voltage matching

LIGHT

- Modbus
- Rotating diode monitoring
- History Logger

BASIC

The **BASIC** version covers all functionality of **LIGHT** in addition to the following:

- Modbus TCP
- VDC mode: Reactive load sharing for up to 31 machines in island operation
- Dual channel/monitoring: Enables the dual channel operation based on self-diagnostics and setpoint follow-up over CAN communication

FULL

The **FULL** version covers all functionality of **BASIC** in addition to the following:

- Synchronization: Fast and reliable build-in synchronizer
- Event logger: Up to 500 events are stored in a non-volatile memory
- Data logger: A data log of 12 signals is saved automatically in the non-volatile memory
- Real-time clock: For accurate time-stamped events and data logs

Power system stabilizer (PSS)

PSS can be an option for UNITROL 1010 LIGHT and BASIC as well as UNITROL 1020 BASIC and FULL AVR modules. Compliant with the standard IEEE 421.5-2005 2A/2B / 2C, the PSS improves the stability of the generator over the highest possible operation range.

UNITROL 1000 software functions overview

	Software functions	UNITROL 1005	UNITROL 1010	UNITROL 1020
ECO	AVR/FCR/PF/VAR Limiters / Temperature - dependency ¹⁾ Protection / Monitoring Soft start / Line charging ¹⁾ Voltage matching	ECO LIGHT	LIGHT BASIC	BASIC FULL FULL + PSS
LIGHT	History logger Modbus TCP Rotating diode monitoring			
BASIC	Reactive load sharing via RS485 (Busbar / Ring structure) Dual channel Auto-synchronization (SYNC)			
FULL	Event logger Data logger Real-time clock Time synchronization by SNTP			
OPTION	Power system stabilizer (PSS)			

¹⁾ Only on UNITROL 1010 and UNITROL 1020

Commissioning and maintenance tool CMT1000

CMT1000 is a commissioning and maintenance tool for the UNITROL 1000 product family. The tool is used to setup all parameters and tune the PID to guarantee stable operation. The CMT1000 software allows an extensive supervision of the system, which helps the user to identify

and locate problems during on-site commissioning. The CMT1000 is connected to the UNITROL 1000 via USB or Ethernet port, where Ethernet connection allows remote access over 100 meters.

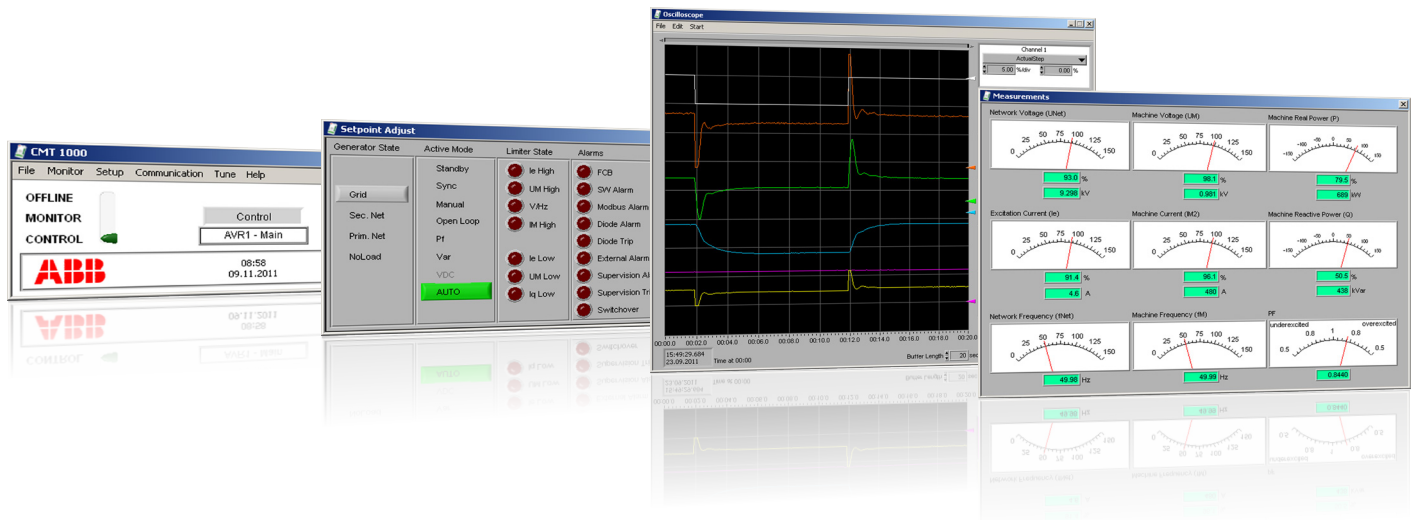

Main window

- Indication of access mode and device information
- Change of parameter is only possible in CONTROL access mode
- LED symbol indicates that all parameters are stored in non-volatile memory

Setpoint adjust window

- Overview of all control modes, alarms, generator and active limiters status
- Setpoint adjustment and application of steps for tuning of the PID

Oscilloscope

- 6 signals can be selected out of 20 recorded channels
- The time resolution is 50ms
- Files can be saved to PC for further investigation

Measurement

- All measurements on one screen

Mechanical dimensions

UNITROL 1005

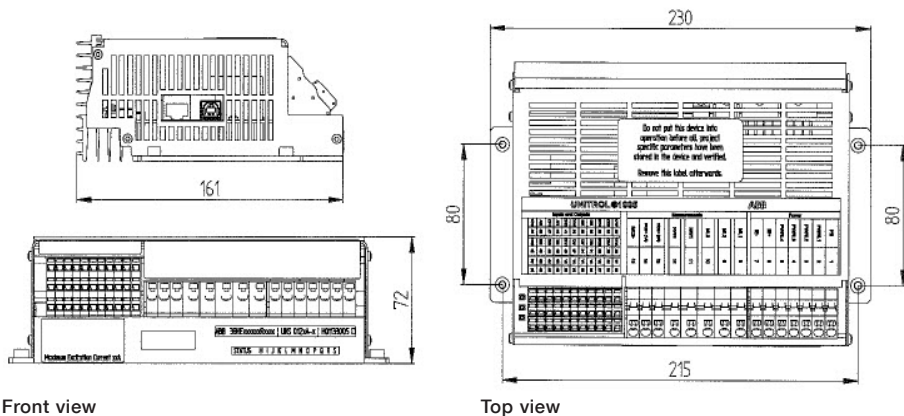

Front view

Top view

UNITROL 1010

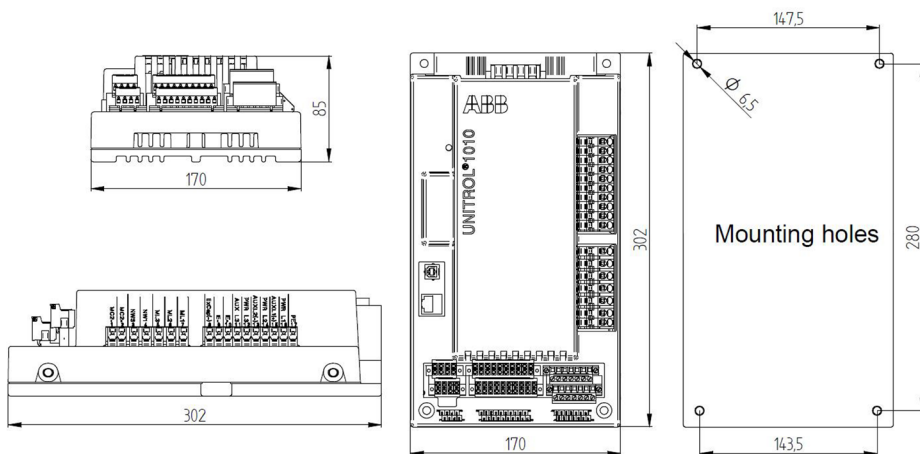

Front view

Top view

UNITROL 1020

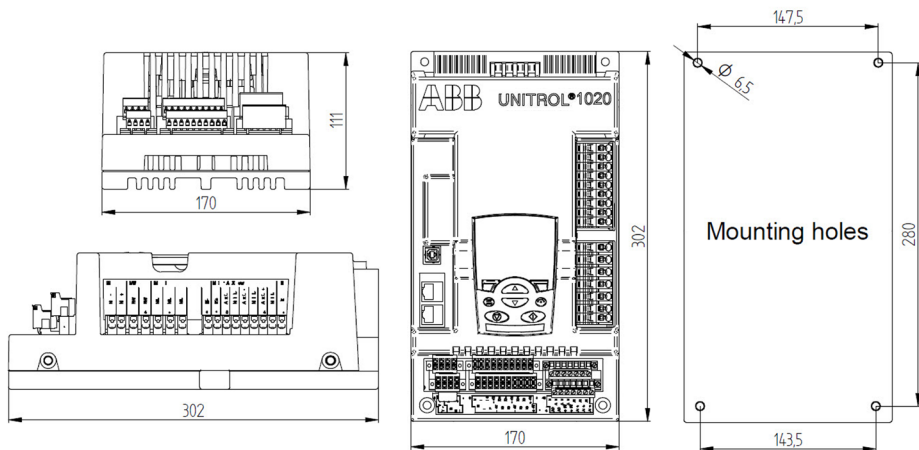

Front view

Top view

Remark: The dimensions are given in millimeter (mm)

Technical data

	UNITROL 1005	UNITROL 1010	UNITROL 1020
Power electronic input (AC/DC)			
AC nominal input voltage	16 to 250 V _{AC}	0 to 250 V _{AC}	0 to 250 V _{AC}
Frequency	40 to 600 Hz	40 to 600 Hz	40 to 600 Hz
DC nominal input voltage	18 to 300 V _{DC}	0 to 300 V _{DC}	0 to 300 V _{DC}
Max. peak input voltage (non sinusoidal)	420 V _P	420 V _P	420 V _P
Min. required start voltage	6V _{AC} / 10 V _{DC}	6V _{AC} / 10 V _{DC}	6V _{AC} / 10 V _{DC}
Auxiliary supply (controller) input			
AC nominal input voltage 3-phase	not supported	9 to 250 V _{AC}	9 to 250 V _{AC}
AC nominal input voltage 1-phase	not supported	16 to 250 V _{AC}	16 to 250 V _{AC}
Frequency	not supported	40 to 600 Hz	40 to 600 Hz
DC nominal input voltage	not supported	18 to 300 V _{DC}	18 to 300 V _{DC}
Max. peak input voltage (non sinusoidal)	not supported	420 V _P	420 V _P
Excitation output			
Continuous current at 55 °C	8 A _{DC}	10 A _{DC}	15 A _{DC} 20 A _{DC} ⁽¹⁾
Overload current for 10 sec. 55 °C	16 A _{DC}	25 A _{DC}	38 A _{DC}
Exciter current measurements			
Full range	0 to 25 A	0 to 38 A	0 to 38 A
Accuracy / Resolution	< 1 % / < 20 mA	< 1 % / < 100 mA	< 1 % / < 100 mA
Machine and net measurements			
Machine voltage, 1-, 2- or 3-phase	up to 500 V _{AC}	up to 500 V _{AC} ⁽²⁾	up to 500 V _{AC} ⁽²⁾
Machine current, 1-phase	1 to 5 A _{AC}	1 to 5 A _{AC}	1 to 5 A _{AC}
Network voltage, 1-phase	up to 500 V _{AC}	up to 500 V _{AC}	up to 500 V _{AC}
Frequency range	10 to 150 Hz	10 to 150 Hz	10 to 150 Hz
Accuracy (-40° to 70°C / at 25°C)	± 1% / 0.1%	± 1% / 0.1%	± 1% / 0.1%
Voltage regulation			
AVR response time (3-phase / 1-phase meas.)	< 20 ms / < 50 ms	< 20 ms / < 50 ms	< 20 ms / < 50 ms
PWM limitation	0.5 to 99 %	0.5 to 99 %	0.5 to 99 %
Digital and analog I/O			
Numbers of digital inputs / outputs (input only / in or out / output only)	8 / 0 / 4	4 / 8 / 0	4 / 8 / 0
Digital IO voltage	24 V	24 V	24 V
±10 V analog I/O, 3 inputs, 2 outputs			
Number of analog inputs / outputs	2 / 0	3 / 2	3 / 2
Analog IO range	± 10 V / 0 ... 20 mA	± 10 V	± 10 V
Communication interfaces			
Ethernet (cable length < 100 m)	10 / 100 MBit/s	10 / 100 MBit/s	10 / 100 MBit/s
USB version (cable length < 3 m)	1.0; 1.1; 2.0	1.0; 1.1; 2.0	1.0; 1.1; 2.0
CAN (cable length < 3 m)	not supported	Only for connections between UNITROL 1000 devices	Only for connections between UNITROL 1000 devices

⁽¹⁾ 3-phase power supply and external 1 mF capacitor required to operate UNITROL 1020 between 15 A and 20 A nominal excitation current.

⁽²⁾ UNITROL 1010 and UNITROL 1020, machine voltage measurement above 250 V_{AC} requires connection of machine star point to earth (PE).

Order codes / Connection diagrams

UNITROL 1005

Material description	Order code
UNITROL 1005-0011 ECO	3BHE043576R0011
UNITROL 1005-0012 LIGHT	3BHE043576R0012

UNITROL 1010 and UNITROL 1020

Material description	Order code
UNITROL 1010-0002 LIGHT	3BHE035301R0002
UNITROL 1010-0003 BASIC	3BHE035301R0003
UNITROL 1020-0003 BASIC	3BHE030579R0003
UNITROL 1020-0006 FULL	3BHE030579R0006
UNITROL 1020-0006 FULL + PSS	3BHE030579R0007

Typical connection diagrams

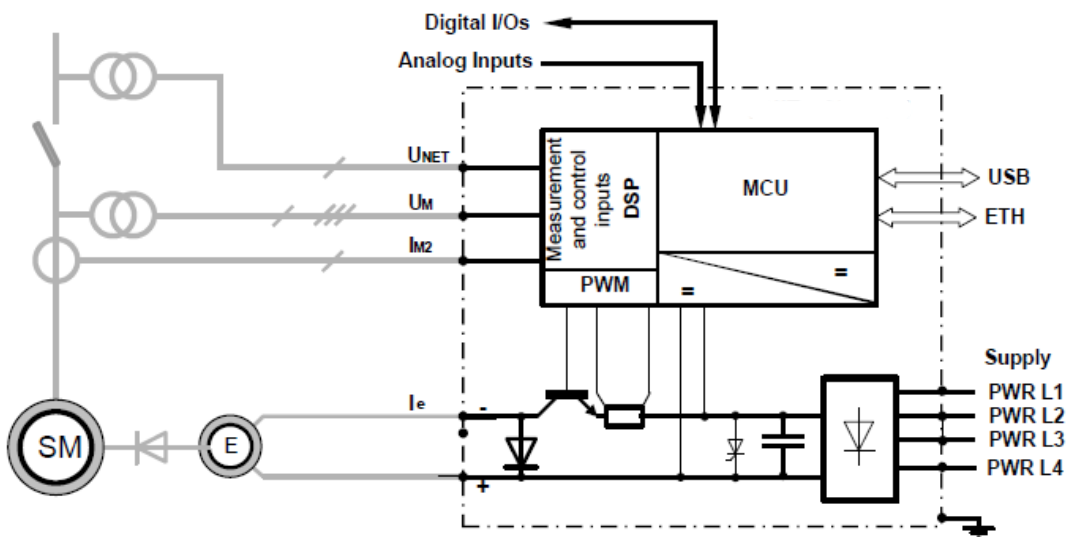

UNITROL 1005

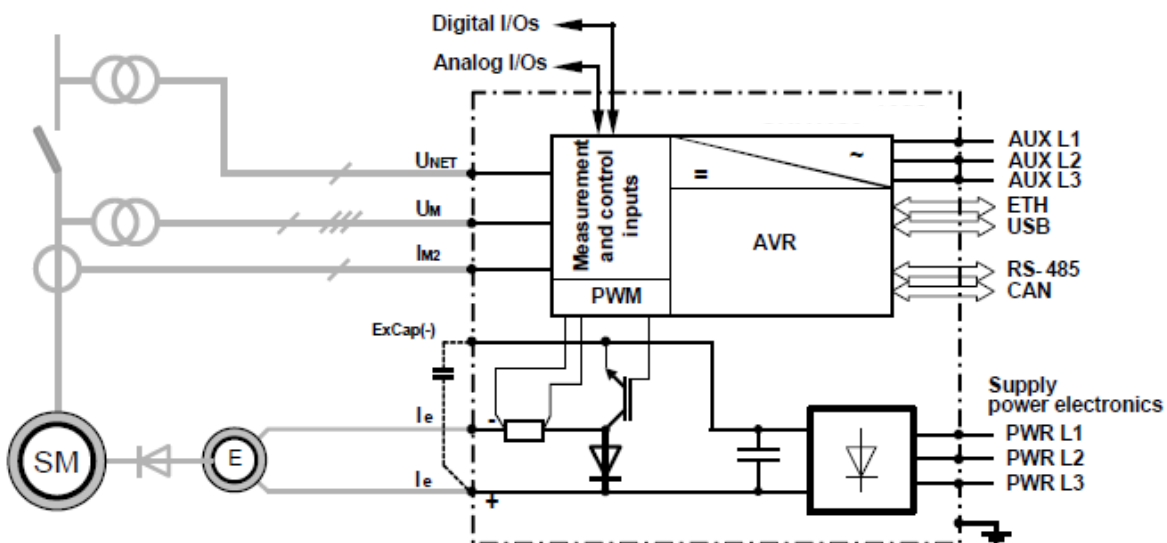

UNITROL 1010 and UNITROL 1020

Grid codes and UNITROL® 1000 systems

Grid codes

Built-in power system stabilizer and fast detection of voltage dips are prerequisites to meet any grid codes.

ABB provides a detailed computer representation of the internal control algorithm and IEEE models for system simulations.

In addition, ABB provides several levels of service:

- Calculation of PSS parameter
- Simulations of reference step responses
- Stability simulations for various different network conditions

ABB provides detailed questionnaires and provides results in a report.

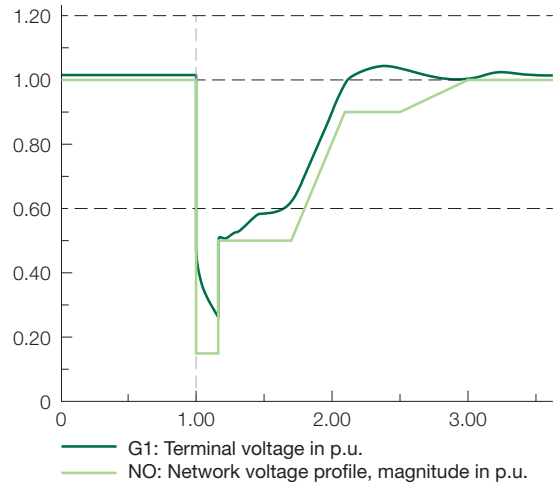

Example of fault-ride-through defined grid code. ABB offers grid code compliant studies in order to prove stability under all circumstances

UNITROL 1000 systems

ABB provides over 100 years of experience in building project-specific engineered systems for any applications.

ABB offers various systems depending on the need of the customer:

- Single channel systems
- Dual channel systems
- Mounting on a plate or in a cubicle

Systems include protection breaker and exciter field breaker. They are fully tested in the ABB factory and AVR setting can be ordered preset.

Ask our expert for more information about:

- Variable speed applications
- Multiple power input sources
- Synchronization of your machine
- I/O extension with external programmable logic controller over fieldbus

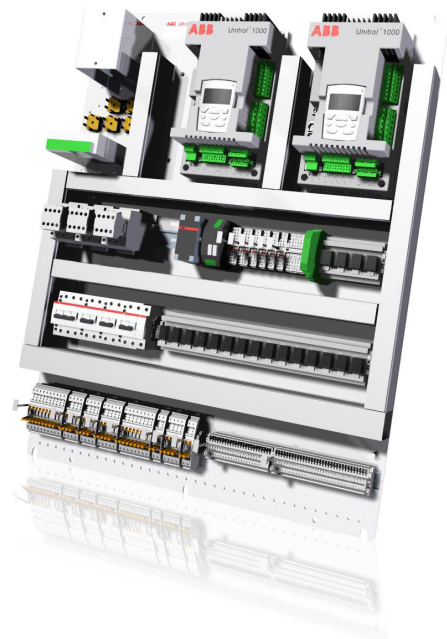

3D model of a dual-channel system on a mounting plate

Service and support

For life cycle management or technical support, the worldwide network of UNITROL specialists is at your service.

Installation and commissioning

The professionalism, extensive experience and multilingual skills of ABB's engineers ensure a satisfactory installation and commissioning.

Training

ABB university offers standard and customized training courses for UNITROL excitation systems. On-site training options are also available. For a detailed training program, visit www.abb.com/abbuniversity

e-Learning

With the UNITROL 1000 interactive e-learning program you decide where and when you learn. The program covers general excitation knowledge as well as detailed product handling know-how.

UNITROL 1000 global support organization

A team of qualified engineers located in different ABB organizations worldwide are ready to support you with your most challenging enquiries and application requirements.

Life cycle management

ABB's excitation systems life cycle management model helps the customers to extend and maximize the life cycle of their assets at minimum costs. Depending on the product's life cycle phase, the service specialists recommend necessary actions and approach the clients pro-actively to inform them about all maintenance, service and upgrade necessities.

Examples of life cycle services

- Technical support for optimized reliability
- Spare parts delivery
- Preventive and corrective maintenance
- Upgrade and modernization

For urgent technical assistance, please call the hotline:

+41 (0)844 845 845

(365 days / 24 hours)

or contact ABB by e-mail:

unitrol1000support@ch.abb.com



Contact us

ABB Switzerland Ltd
Excitation Systems and
Synchronizing Equipment
CH-5300 Turgi, Switzerland
Phone: +41 (0)58 589 24 86
Fax: +41 (0)58 589 23 33
E-Mail: pes@ch.abb.com

www.abb.com/unitrol

© Copyright 2016 ABB. All rights reserved. Specifications subject to change without notice.