

ELECTRIC CHAIN HOISTS "VK" SERIES

1 chain fall for capacity from 125 to 2000 kg

CE



Innovation by Tradition





“Innovation by tradition”

VHT Varese Hoisting Technology S.r.l., for the long experience of its engineers of technical design and production in lifting equipment, is able to offer in the world's market the most modern technical-technological compendium, reliable and economical, relating to lifting equipment as standard.

The electric chain hoists “**VK**” series, for capacity from 125 to 2.000 kg, are designed and manufactured using cutting-edge design techniques, which use a 3D CAD system integrated with finite element methods. The rigorous life and reliability testing, which the electric chain hoists “**VK**” are submitted in the modern experience department specifically set up at the VHT, assure compliance to the standard rules and project data, within highest quality standard.

VHT Varese Hoisting Technology S.r.l. produces, in a highly serialized way, electric chain hoists “**VK**”, with the benefit of industrialized production processes controlled by a **quality system conducted according to UNI EN ISO 9001:2000**

A RIGOROUS PROCESS CONTROL

- **The electric chain hoists “VK” series, for capacity from 125 to 2000 kg, are machine generally used to lift an unguided load by means of a hook or handling accessories suitable for the purpose.**
- **The trolleys “VT” series, electric or manual, suitable to run on a beam, when combined with a hoist ensures the integrated handling of lifting and horizontal movements of the load.**
- **The electric chain hoists “VK” series with related trolleys “VT” series can be fitted on monorails or can constitute the lifting unit of other machines in which they have been incorporated in lifting, such as: jib cranes, bridges crane, etc.**
- **The electric chain hoists “VK” series are also used for lift loads in a fixed position.**

THE ELECTRIC CHAIN HOISTS “VK” SERIES AND THEIR TROLLEYS “VT” SERIES

- **All the electric chain hoists “VK” series, for capacity from 125 to 2000 kg, besides being characterized by a modern and compact design that ensures maximum use of hook travel, are designed exclusively to a single fall of the chain. This solution provides **maximum safety for the operator** because, due to the absence of the transmission reel in the hook block, completely eliminate all potential causes of hazards due to possible kinking of the chain. Moreover, for the absence of transmission reels in the execution to a single fall of the chain, the wear of the chain itself is reduced to a minimum with the increase of its life. This leads to an important reduction of maintenance costs and to the **highest functional reliability.****
- **Safety and Reliability = 3 years warranty from the delivery date.**

ELECTRIC CHAIN HOISTS “VK” WITH ONLY 1 FALL CHAIN = SAFETY AND RELIABILITY



THE RANGE OF ELECTRIC CHAIN HOISTS

“VK” SERIES:



The range of the electric chain hoists is produced in 3 sizes: “VK2” - “VK3” - “VK4”; for capacity from 125 to 2.000 kg; in the FEM service groups FEM 2m (ISO M5) and FEM 3m (ISO M6); with one or two lifting speed (4 m/min - 8 m/min - 16 m/min or 4/1 m/min - 8/2 m/min - 16/4 m/min); with standard lifting height up to 12 m.

STANDARD EXECUTIONS:

- **Fixed configuration**, suspended with eyebolt or hook on request;
- **Hoist with manual trolley**, the horizontal movement is done by pushing of the load;
- **Hoist with electric trolley**, the horizontal movement is done by an electric motor and is controlled by the hoist push button panel.

Reference frame:

The electric chain hoists “VK” series and related trolleys “VT” series are comply to the **Essential Requirements of Safety in attachment I** of the **Community Directive 2006/42/CE** and are, therefore, provided with **EC Declaration of Conformity of Annex IIA** and **CE marking in Annex III** of the Directive.

In addition, electric chain hoists “VK” and related trolleys “VT” comply with the **Low Voltage Directive 2006/95/EC** and the **EMC Directive 2004/108/EC**.

Reference frame:

In the design and assembling of the electric chain hoists “VK” series and related trolleys “VT” series, were taken into consideration the following main technical standards and regulations:

- EN ISO 12100:2010 “Essentials principles for design concepts”
- EN ISO 13849-1:2008 “Parts of control systems related to safety”
- EN 818-7:2008 “Thin tolerance chain for hoists”
- EN 13135-1:2010 “Lifting equipment - Part 1 – Electro technical equipment”
- EN 13135-2:2010 “Lifting equipment - Part 2 – Equipment not electro technical”
- EN 12077-2:2008 “Limiting and indicating devices”
- EN 13001-1:2009 “Lifting equipment – General criteria for design - Part 1 – General principles and Requirements”
- EN 13001-2:2011 “Lifting equipment – General criteria for design - Part 2 – Loads actions”
- EN 13001-3-1:2012 “Lifting equipment – general criteria for design - Part 3-1 – Stress limit”
- EN 14492-2:2009 “Lifting equipment - Part 2: Electric hoists”
- EN 60204-32:2008 “Safety of the electric equipment of lifting machines”
- EN 60529:1997 “IP enclosures”
- ISO 4301-1:1988 “Classification of lifting equipment.”
- DIN 15400 “choice of the lifting hooks – Mechanical properties and capacities”
- DIN 15401 “Choice of the lifting point hooks”
- FEM 1.001/98 “Calculation of the lifting equipment”
- FEM 9.511/86 “Classification of the mechanisms”
- FEM 9.671/88 “Choice of the chains”
- FEM 9.683/95 “Choice of lifting and traverse motors”
- FEM 9.755/93 “Periods of safe work”
- FEM 9.761/93 “Overload devices”
- FEM 9.941/95 “Controls symbols”

Enclosure and insulation of electrical components:

- Lifting and travelling motors: IP55 protection – Class “F” insulation
- Limit switches: IP65 minimum protection – Maximum insulation voltage 500 V
- Cables: CEI 20/22 II – Maximum insulation voltage 450/750 V
- Protections and insulations different from standard are available on request.

Electric power supply:

- The electric chain hoists “VK” series and related trolleys “VT” series are suitable, as standard, to be supplied with alternate electric current with three-phase voltage of 400 V +/- 10%.
- Voltage and frequency different from standard or execution with one-phase alternate current are available on request.

Working conditions in standard execution:

- Working temperature: minimum - 10° C; maximum + 40°C
- Maximum relative humidity: 90%
- Maximum altitude 2.000 m above sea level
- The hoist must be installed indoor, in a well ventilated environment free of corrosive vapors (acid vapors, salin mist, etc.).



- Special executions, for different environments or outdoor installation are available on request.

Noise – vibrations:

The noise level emitted by electric chain hoists “VK” series and related trolleys “VT” series, in a fully loading condition, is always less than 75 dB (A), measured at 1 m of distance and at 1,6 m from the ground.

The vibrations produced by the hoist are not hazardous for the health of the workers.

Classification of the service group of the electric chain hoists “VK” series:

The electric chain hoists “VK” series are designed and are classified in consideration of standard EN 13001-1, so as to operate according to the parameters relating to the service group corresponding to FEM 2m or 3m (FEM 9.511/86) or ISO M5 or M6 (ISO 4301-1:1986).

The duty cycle of the motor is improvement compared to the minimum requirements provided by rule FEM 9.683/95.

SERVICE GROUP OF THE MECHANISMS		ACCORDING TO EN 13001-1 CORRESPONDING TO FEM 2m OR 3m (FEM 9.511/86) OR ISO M5 OR M6 (ISO 4301-1:1986)																	
HOIST SPEED		ONE SPEED HOIST (MOTOR WITH SINGLE POLARITY 2 POLES)						TWO SPEEDS HOIST (MOTOR WITH DOUBLE POLARITY 2 / 8 POLES)											
								MAIN SPEED (FAST POLARITY - 2 POLES)						AUXILIARY SPEED = 1/4 OF MAIN SPEED (SLOW POLARITY - 8 POLES)					
INTERMITTENT USE OF THE HOIST	RATIO OF INTERMITTENCE (RI%)	60 %						40 %						20 %					
	N° START-UPS PER HOUR (A/h)	360 (with 6 starting per cycle)						120 (with 6 starting per cycle)						240 (with 6 starting per cycle)					
	N° CYCLES PER HOUR (C/h)	10	20	30	40	50	60	10	20	30	40	50	60	10	20	30	40	50	60
	AVERAGE RUN (Ce) OF THE HOOK (m) WITH MAIN SPEED OF:	4 m/min	7,2	3,6	2,4	1,8	1,45	1,2	4,8	2,4	1,6	1,2	0,95	0,8	0,6	0,3	0,2	0,15	0,12
	8 m/min	14,4	7,2	4,8	3,6	2,9	2,4	9,6	4,8	3,2	2,4	1,9	1,6	1,2	0,6	0,4	0,3	0,25	0,2
	16 m/min	28,8	14,4	9,6	7,2	5,8	4,8	19,2	9,6	6,4	4,8	3,8	3,2	2,4	1,2	0,8	0,6	0,5	0,4

Criteria of choice for the electric chain hoists “VK” series:

In order to choose the right hoist for the required service it's important consider the following factors:

1. **The capacity of the hoist:** is determined by the maximum load to lift
2. **The loading rate (Q):** is the stress level due by the percentage of use of the capacity (average of the loads to be lifted)
3. **The average daily running time - Tm (hours) and the maximum number of working cycles CA,** calculated with the following formulas:

$$Tm \text{ (hours)} = \frac{2 \times Cm \times C/h \times Ti}{60 \times V}$$

$$C_A = C/h \times Ti \times G/\text{year} \times A$$

where: **Cm** = Real lifting height (m) – It's the average of the used lifting height

C/h = Operating cycles (N° cycles per hour) – It's the number of complete up/down operations per hour

Ti = Hoist running time (hours) – It's the hoist running time in the whole day

V = Lifting speed (m/min) – It's the distance covered by the load in a minute

A = Years of service (N° years) – It's the number of years, not less than 10 , for which the life of the machine is calculated

In relation to the Loading rate (Q) and the Average daily running time (Tm) is determined the service group FEM/ISO.

OPERATING CYCLES AND LIFE OF THE MECHANISMS IN RELATION TO THE LOADING RATE (Q), THE AVERAGE DAILY RUNNING TIME (Tm) AND THE SERVICE GROUP FEM/ISO							
LOADING RATE (Q) ACCORDING TO STANDARD EN 13001-1		CORRELATION BETWEEN THE LOADING RATE ACCORDING TO STANDARD EN 13001-1 AND SERVICE GROUPS FEM 9.511/86 (ISO 4301-1:1986)					
		SERVICE GROUP FEM 2m (ISO M5)			SERVICE GROUP FEM 3m (ISO M6)		
Q	% OF MAX. LOAD (% USE OF THE CAPACITY)	OPERATING CYCLES OF THE HOIST (n°)	LIFETIME OF THE HOIST (HOURS)	AVERAGE DAILY RUNNING TIME Tm (HOURS)	OPERATING CYCLES OF THE HOIST (n°)	LIFETIME OF THE HOIST (HOURS)	AVERAGE DAILY RUNNING TIME Tm (HOURS)
Q ₀	> 25% ≤ 32%	> 2.000.000 ≤ 4.000.000	50.000	> 16	> 4.000.000 ≤ 8.000.000	100.000	> 16
Q ₁	> 32% ≤ 40%	> 1.000.000 ≤ 2.000.000	25.000	> 8 ≤ 16	> 2.000.000 ≤ 4.000.000	50.000	> 16
Q ₂	> 40% ≤ 50%	> 500.000 ≤ 1.000.000	12.500	> 4 ≤ 8	> 1.000.000 ≤ 2.000.000	25.000	> 8 ≤ 16
Q ₃	> 50% ≤ 63%	> 250.000 ≤ 500.000	6.300	> 2 ≤ 4	> 500.000 ≤ 1.000.000	12.500	> 4 ≤ 8
Q ₄	> 63% ≤ 80%	> 125.000 ≤ 250.000	3.200	> 1 ≤ 2	> 250.000 ≤ 500.000	6.300	> 2 ≤ 4
Q ₅	> 80% ≤ 100%	> 63.000 ≤ 125.000	1.600	> 0,5 ≤ 1	> 125.000 ≤ 250.000	3.200	> 1 ≤ 2

The type of electric chain hoist “VK” series is selected, in the table “CHARACTERISTICS AND TECHNICAL DATA”, according the capacity of the hoist as well as other factors, determined or calculated, that characterize the intended use (Loading rate, Average daily running time and Service Group FEM/ISO)

Example:

- Maximum load: 500 kg → Capacity of the hoist “VK” = 500kg
- Average of the loads to be lift: 300 kg → Loading rate = Q₃
- Average of the used lifting height: 1,5 m → Real lifting height Cm = 1,5
(corresponding to class D_{lin2} of the standard EN 13001-1)
- Up/down lifting operations per hours → N° cycles per hours C/h = 20
- Use on a working shift → Ti (hours) = 8
- Lifting speed: 4/1 m/min → Main speed V = 4
- Working days per year: 250 → D/year = 250

Calculation of the average daily running time (hours) of daily use:

$$T_m = \frac{2 \times C_m \times C/h \times T_i}{60 \times V} = \frac{2 \times 1,5 \times 20 \times 8}{60 \times 4} = 2 \text{ hours}$$

Calculation of the number of operating cycles (CA) carried out in 10 years:

$$C_{10} = C/h \times T_i \times G/\text{year} \times 10 = 20 \times 8 \times 250 \times 10 = 400.000 \text{ cycles}$$

(corresponding to class U5 of the standard EN 13001-1)

On the basis of the determined and calculated factors, the service group is: Q3 - U5 - D_{lin2} according to the standard EN 13001-1, corresponding to FEM 2m (ISO M5). Therefore, the electric chain hoist “VK” series suitable for the use shall be: **K2DN1D**



THE COMPONENTS OF THE ELECTRIC CHAIN HOISTS “VK” SERIES AND TROLLEYS “VT” SERIES

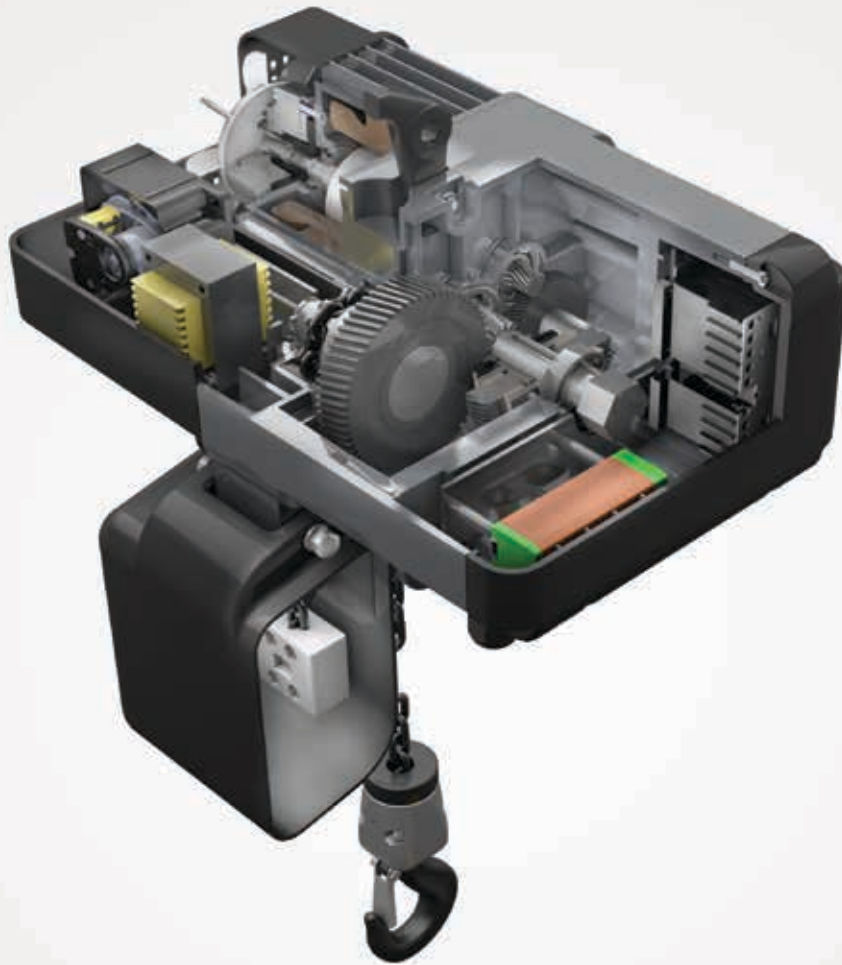

Reduction gear: designed to allow the maximum lifting height of the hook, is designed to withstand to fatigue and wear for the whole lifetime expected by the selected service groups FEM/ISO (2m/M5 or 3m/M6). The gear has parallel axes, with heat shrink between pinions/shafts and their crowns, it is totally closed and contained in boxes in cast light alloy. The cylindrical gears with helicoidally teeth are thermally treated and made of highly resistant steel. The gears are mounted on spherical bearings and are lubricated for life in an oil bath.

Suspension eye: made in hot-pressed carbon steel, is fixed by two steel pins to the hoist body easily inspected but such us to prevent removal accidental leakage. The suspension eye, as provided with fixing holes and eyebolt, allows both the rigid suspension of the hoist by means of the two holes, or by means of the oscillating eyebolt.

The hook suspension version is available on request.

Self-breaking motor: asynchronous three-phase cylindrical rotor. The brake, electromagnetic type in direct current, is designed for a high number of starting, does not require any adjustment and the braking gasket is free of asbestos. The casing, made of light alloy, has radiating fins that guarantee high thermal dissipation. The motor is also fan cooled externally and is produced with of single polarity for hoists at one speed or double polarity to those at two speeds.

Lifting chain: calibrated round steel high strength, special quality with high dynamic stability, guaranteed minimum tensile strength of 800 N/mm² and break elongation more than 10%, in accordance with EN 818-7. The safety coefficient is always more than 6. The heat and galvanizing treatments applied to the chain ensure high resistance to the wear, aging and corrosion.

Load sprocket: with pentagonal imprints, is made of high strength steel and has imprints mechanically worked subjected to heat treatment of hardening that ensure optimum sliding and a long life of the chain and the sprocket.

Chain guide: provides the insertion and extraction of the chain links into the load sprocket imprints, both in ascent and descent.

Load hook: point hook, rotates on thrust bearing, is made of high strength forged steel and is supplied with safety latch against the accidental release of the load.

Hook block: made with two light alloy semi-casing connected together by bolts. It has suitable seats for the housing of the hook. By the loading pin, heat treated, it connect the chain to the hook and permits the hook rotation.

Upper limit buffer: it consists in a polyurethane shock absorber, cylindrical shape with a central hole for the chain crossing, is placed against the upper surface of the hook block. It deadens and reduces the dynamic effects caused by the collision of the hook block against the hoist body in the upper hook position, it causes the clutch device slipping avoiding the impact between metallic parts.

Descent limit stop: made in high resistance plastic material reinforced with fibreglass, is placed on the descending length of chain into the chainbox. It has function to adjust and limit the descent hook run. On request is available for adjust and limit the ascent hook run.

Chainbox: made in shock-resistance plastic is swinging fixed to the hoist body by a bolt that permits high level of freedom of movement. Is provided in several sizes in order to contain the length of chain for the required hook path.

Clutch device – overload device: is a safety device with function of up and down stop limit and, if provided, by overload device. The use of limit stops of the chain in ascent and descent is fixed for all the lifting equipment, while the overload device is fixed only for hoists with capacity equal or more of 1000 kg.

The clutch device is composed by a friction coupling with double pressure disc, with friction gasket asbestos free. The sliding surfaces are in oil bath in order to guarantee the dissipation of the heat generated during the slipping. The clutch device is pre-loaded by means of spring washers and adjusting nut.

The slipping of the clutch device, when it has overload device function, is automatically generated in any point of the hook travel, whenever the resistance force caused by the load is more than the resistance force of the device (ex.: in overload situation).

Electric lifting limit switch: for ascent and descent is provided as “optional” for all the electric chain hoists “VK” series.

They are made of two precision micro switches which function according to the principle of “slow positive opening” and work on the auxiliary circuit of the control device of the lifting motor.

The electric limit switch, rotary type, is protect against the atmospheric agents (IP 55 protection), is of simple calibration and inspection. It is connected to the slow shaft of



the load sprocket. Due by its location can adjust the position of the hook in ascent and descent independent by the hook action and in this case is free by risk of accidental collision with the hook or the load.

Electrical controls: for activate the ascent and descent functions and , when provided , the right and left functions of the electric trolley. Is designed and made in comply with the standard EN 60204-32, while the choice of the components is comply with the standard EN 60947-5-1.

The electrical control, fixed in suitable sites into the hoist or, when provided, on the trolley motor, includes:

- the auxiliary circuits in low voltage 110 V in CA powered by mono-phase transformer;
- the power circuits (power supply and motors) suitable for three-phases in CA max. 500 V;
- the equipotential earth circuit;
- the mono-phase transformer for the power supply of the low voltage circuit, in comply with the standard EN 61558-1;
- the general line contactor designed in AC2;
- the contactors for motor power control, designed AC3, with electric and mechanic block between opposite functions
- the contactors for polarity change in case of hoists and trolley with two speeds;
- the protections of the main and auxiliary circuits of the transformer, included in the transformer itself;
- the terminal block for the connections of the auxiliary and power circuits;
- the glands for the entry and exit of all the users (main power, motors, push button panel, limit switches), equipped with minimum grade protection IP 55, in comply with the standard EN 60529;
- the box covers are in shockproof thermoplastic self-extinguishing material, equipped of gasket in order to guarantee the grade protection IP 55 of the controls, in comply with the standard EN 60529.

Push button panel: with its relative cable is equipped by:

- ergonomic shape easily gripping, equipped with controls of immediate access requiring low operating forces;
- external protection box made in shockproof thermoplastic self-extinguishing material , waterproof with protection grade IP 67, in comply with the standard EN 60529;
- function buttons with kept action, protect against the accidental control, with electric block and functions remarkable by symbolism in comply with the regulation FEM 9.941/95;
- emergency stop, in comply with the standards EN 418 and EN 60947-5-1, made with a red mushroom-head button which using an intentional release action puts the control circuit in the forward position;
- multipolar electric cable, fire retardant type comply with the standard CEI 20 22 II, is equipped with tear proof metallic parts for the push button panel suspension.

Trolleys "VT" series: suspend the electric chain hoist "VK" series and permit its movement along a monorail beam with the horizontal travel of the load.

The trolleys run on the lower flanges of the beam and are adjustable for flange width. Their plates are made in steel plates cut with laser and then bend-pressed. Their design include stirrups to prevent drop or derailing

The trolley plates including, as standard, of buffers with high energy absorbing.

The trolleys are available in two different executions:

The hand pushed trolley type "VT"-S, is equipped by:

Idle wheels, rotating on permanently lubricated ball bearings that can be:

- a. *n° 4 wheels for capacity up to 500 kg or n° 8 wheels for capacity up to 1.000 kg. The wheels are in high resistance plastic material and give to the trolley an high sliding because they are manufactured without edges. It avoid friction due by the contact between the edges and the flange of the beam. In this execution the alignment of the trolley on the beam is guarantee by suitable rollers guide made in no-wear plastic material and, due by the low pushing forces, the trolley is especially suitable for frequently use with loads near the maximum capacity ;*
- b. *n° 4 wheels in pressed steel, machined with guide edges for capacity 1.000 kg. This execution guarantee the maximum horizontal draw due by the small size of the 4 wheels trolley against the 8 wheels trolley but in this case there are higher pushing forces. For this reason is recommended for casual use with loads near the maximum capacity.*

The electric trolley, type “VT”-E, is equipped by:

- *n° 4 wheels, 2 drives and 2 idles, in pressed steel, machined with guide edges, rotating on permanently lubricated ball bearings;*
- *motor reducer that gives the movement to the drive wheels. It is provided with self-breaking motor with cylindrical rotor and electromagnetic brake, with soft starting and stop at one or two speed with single or double polarity;*
- *travel limit switch, as standard, for control in safety of the horizontal travel of the electric trolley on the beam;*

For all the trolleys “VT” series, hand pushed or electric, is available as optional the towing arm which is the connecting element between the trolley and the power suppl. It is easily adjustable in all directions and avoid the wires tear.



CHARACTERISTICS AND TECHNICAL DATA OF THE ELECTRIC CHAIN HOISTS “VK” SERIES WITH TROLLEYS “VT” SERIES

ELECTRIC CHAIN HOIST “VK” SERIES						COMBINING OF THE CHAIN HOIST “VK” SERIES WITH TROLLEY “VT” SERIES									
CAPACITY	SPEED ²⁾	SERVICE GROUP FEM (ISO)				TYPE OF MOVEMENT:		MOTOR POWER ¹⁾ (kW) OF THE ELECTRIC TROLLEY TYPE M TO:							
		2m (M5)		3m (M6)		HAND-PUSHED	ELECTRIC	1 SPEED ²⁾		2 SPEED ²⁾					
(kg)	(m/min)	TYPE	POWER ¹⁾ (kW)	TYPE	POWER ¹⁾ (kW)	TYPE S	TYPE M	8 m/min	16 m/min	16/4 m/min					
125	8,0	→	→	K2AV1S	0,18	TS1	TE2	0,09	0,18	0,18/0,04					
	8,0/2,0	→	→	K2AV1D	0,18/0,04										
	16,0	K2AR1S	0,37	K3AR1S	0,75										
	16,0/4,0	K2AR1D	0,37/0,09	K2AR1D	0,75/0,18										
250	4,0	→	→	K2CN1S	0,18										
	4,0/1,0	→	→	K2CN1D	0,18/0,04										
	8,0	K2CV1S	0,37	K3CV1S	0,75										
	8,0/2,0	K2CV1D	0,37/0,09	K3CV1D	0,75/0,18										
	16,0	K3CR1S	0,75	K4DR1S	1,5										
	16,0/4,0	K3CR1D	0,75/0,18	K4DR1D	1,5/0,36										
500	4,0	K2DN1S	0,37	K3DN1S	0,75						TS3	TE3	0,09	0,18	0,18/0,04
	4,0/1,0	K2DN1D	0,37/0,09	K3DN1D	0,75/0,18										
	8,0	K3DV1S	0,75	K4DV1S	1,5										
	8,0/2,0	K3DV1D	0,75/0,18	K4DV1D	1,5/0,36										
	16,0	K4DR1S	1,5	=	=										
	16,0/4,0	K4DR1D	1,5/0,36	=	=										
1000	4,0	K3EN1S	0,75	K4EN1S	1,5	TS2	TE2	0,09	0,18	0,18/0,04					
	4,0/1,0	K3EN1D	0,75/0,18	K4EN1D	1,5/0,36										
	8,0	K4EV1S	1,5	=	=										
	8,0/2,0	K4EV1D	1,5/0,36	=	=										
2000	4,0	K4FN1S	1,5	=	=	TS3	TE3	0,09	0,18	0,18/0,04					
	4,0/1,0	K4FN1D	1,5/0,36	=	=										

¹⁾ The powers are referred with supply voltage of 400 V at 50 Hz

²⁾ The stated speeds are referred at frequency of 50 Hz

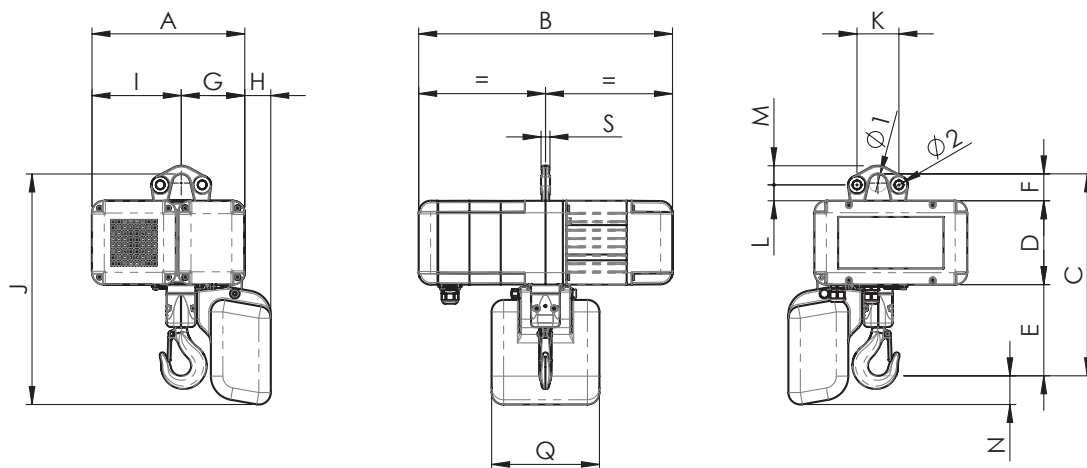

SIZE HOIST "VK" SERIES	OVERALL DIMENSIONS (mm)															WEIGHT ¹⁾ (kg)
	A	B	C	D	E	F	G	I	J	K	L	M	S	Ø1	Ø2	
2	255	425	340	140	155	45	106	149	385	70	27	32	15	30	14	31
3	300	475	400	165	190	45	128	172	410	70	30	30	18	30	14	48
4	340	560	490	200	240	56	145	195	585	90	36	34	25	35	20	75

¹⁾ Weight referred to the hoist with 3 meter lifting height

SIZE HOIST "VK" SERIES	CHAIN DATA (IN AGREEMENT WITH EN 818-7)		CHOICE OF THE CHAINBOX AND RELATIVE OVERALL DIMENSIONS IN FUNCTION OF THE LIFTING HEIGHT															
			SIZE 1			SIZE 2			SIZE 3			SIZE 4						
			LIFTING HEIGHT (m)	DIMENSIONS (mm)		LIFTING HEIGHT (m)	DIMENSIONS (mm)		LIFTING HEIGHT (m)	DIMENSIONS (mm)		LIFTING HEIGHT (m)	DIMENSIONS (mm)					
	Ø X PITCH (mm)	WEIGHT EACH METER (kg/m)		H	N	Q		H	N	Q		H	N	Q		H	N	Q
2	5x15	0,58	6	42	45	180	12	70	99	225	24	77	174	270	48	85	219	310
3	7x21	1,16	3	32	10	180	6	60	64	225	12	87	139	270	24	95	184	310
4	10x28	2,42	=	=	=	=	=	=	=	=	6	90	50	270	12	97	95	310

13

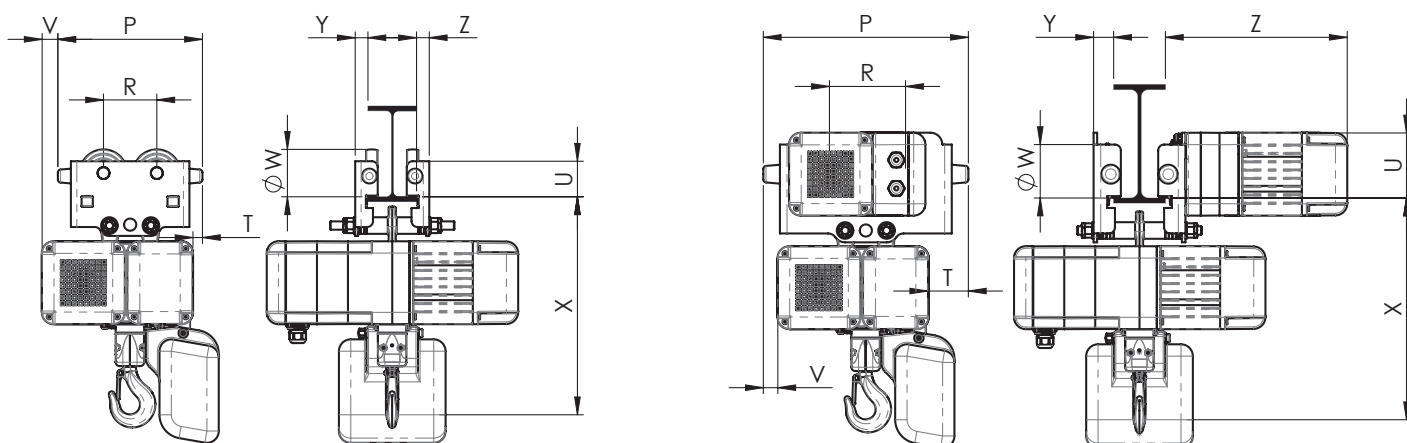

SIZE HOIST "VK" SERIES	TROLLEY "VT" SERIES		OVERALL DIMENSIONS (mm)									DIMENSION OF THE FLANGE OF THE RUNNING BEAM (mm)			WEIGHT ¹⁾ HOIST + TROLLEY (kg)		
			MOVEMENT	TYPE	P	R	T	U	V	ØW	X ²⁾	Y	Z	WIDTH		THICKNESS MAX	
														MIN			MAX
2	Hand-push	TS1	244	90	16	60	-27	80	371	22	22	58	400	16	36		
	electric	TE2	346	134	67	110	24	80	380	28	300	64	400	16	65		
3	Hand-push	TS1	244	90	-6	60	-50	80	431	22	22	58	400	16	53		
	electric	TE2	346	134	45	110	1	80	440	28	28	64	400	16	59		
4	Hand-push	TS3	386	159	48	118	-2	100	550	36	36	82	400	19	97		
	electric	TE3	386	159	48	118	-2	100	550	36	308	82	400	19	103		

¹⁾ Weight referred to the hoist with 3 meter lifting height

²⁾ For flange width with dimension more than the value stated in this table, the dimension X increases of 50 mm for hoists size 2 and 3 and 70 mm for hoist size 4



MAXIMUM REACTIONS ON BEAM FLANGE AND ON THE WHEELS OF THE TROLLEYS "VT" SERIES

SIZE HOIST "VK" SERIES	CAPACITY (kg)	TROLLEY TYPE "VT" SERIES	OVERALL DIMENSIONS (mm)			REACTION TO THE WHEEL R MAX. ¹⁾ (N)
			Ø W	a	b	
2	125	TS1	80	6	14	395
		TE2	80	6	15	466
	250	TS1	80	6	14	701
		TE2	80	6	15	773
	500	TS1	80	6	14	1315
		TE2	80	6	15	1386
3	250	TS1	80	6	14	743
		TE2	80	6	15	814
	500	TS1	80	6	14	1356
		TE2	80	6	15	1427
	1000	TS2	80	6	15	2597
		TE2	80	6	15	2654
4	500	TS3	100	9	20	1464
		TE3	100	9	20	1528
	1000	TS3	100	9	20	2690
		TE3	100	9	20	2754
	2000	TS3	100	9	20	5143
		TE3	100	9	20	5207

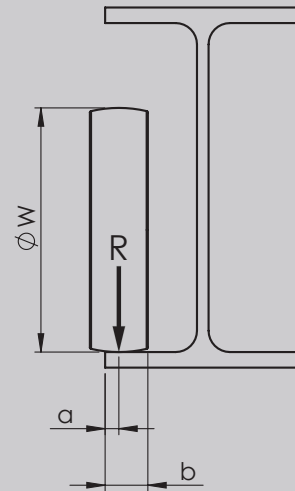

14 ¹⁾ R max. = Maximum reaction on single wheel calculated considering a dynamic coefficient of di 1,15

ELECTRIC CHARACTERISTICS OF MOTORS, FUSES AND POWER CABLES OF HOISTS "VK" AND TROLLEY "VT"

SERIES	SIZE OR TYPE	INSTALLED POWER (kW)	NOMINAL CURRENT In (A)	STARTING CURRENT Ia (A)	POWER FACTOR cos. φ	FUSES (A)	POWER CABLE SECTION (MAX. DROP VOLTAGE ΔU = 20V)	
							Ø WIRES (mm ²)	LENGTH MAX. (m)
Hoist "VK"	2	0,18	1,0	3,4	0,78	4	1,5	≤100
		0,18/0,04	0,9/0,8	3,1/1,4	0,75/0,6	4	1,5	≤100
		0,37	1,4	4,9	0,77	4	1,5	≤100
		0,37/0,09	1,3/0,9	4,7/1,6	0,75/0,58	4	1,5	≤100
	3	0,75	2,3	8,2	0,79	4	1,5	≤100
		0,75/0,18	2,1/1,6	7,7/2,9	0,77/0,62	4	1,5	≤100
	4	1,5	3,7	13,5	0,82	6	1,5	≤70
		1,5/0,36	3,5/1,9	12,8/3,1	0,8/0,62	6	1,5	≤70
Trolley "VT"	TE2 TE3	0,09	0,8	2,4	0,65	4	1,5	≤100
		0,18	0,9	2,7	0,74	4	1,5	≤100
		0,18/0,04	0,9/0,7	2,6/1,2	0,72/0,6	4	1,5	≤100

Note: data referred to motors with supply voltage of 400V and frequency of di 50Hz



VHT s.r.l.
Varese Hoisting Technology

Via Risorgimento 29, 21020 Bodio Lomnago (VA), Italy
Tel +39 0332-948164 Fax +39 0332-949757
www.vhtitaly.com info@vhtitaly.com